

THIS DRAWING IS UNPUBLISHED. RELEASED FOR PUBLICATION
 © COPYRIGHT - By - ALL RIGHTS RESERVED.

REVISIONS							
LOC	DIST	P	LTR	DESCRIPTION	DATE	DWN	APVD
-	-	A		PRODUCTION RELEASE PER ECO-13-014747	9-18-13	CT	RL

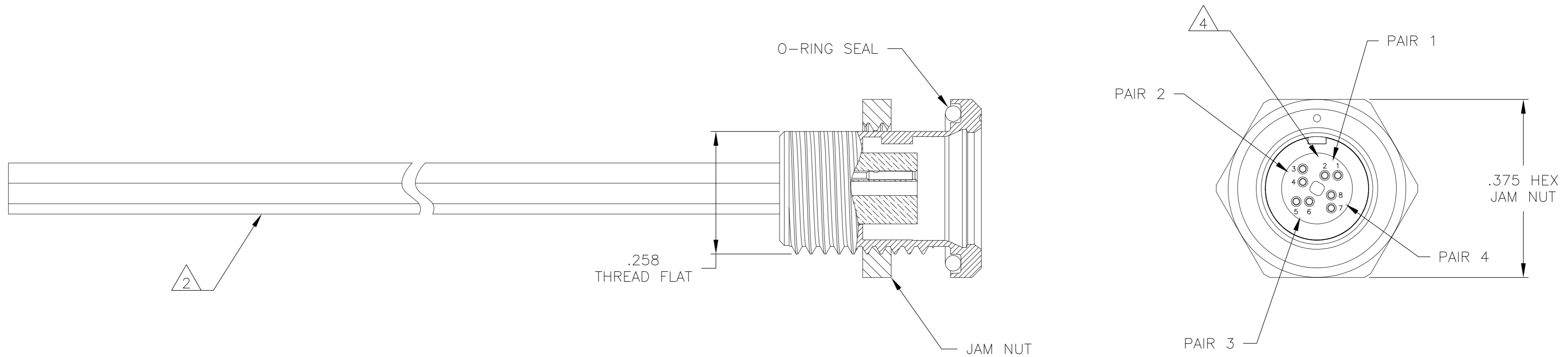
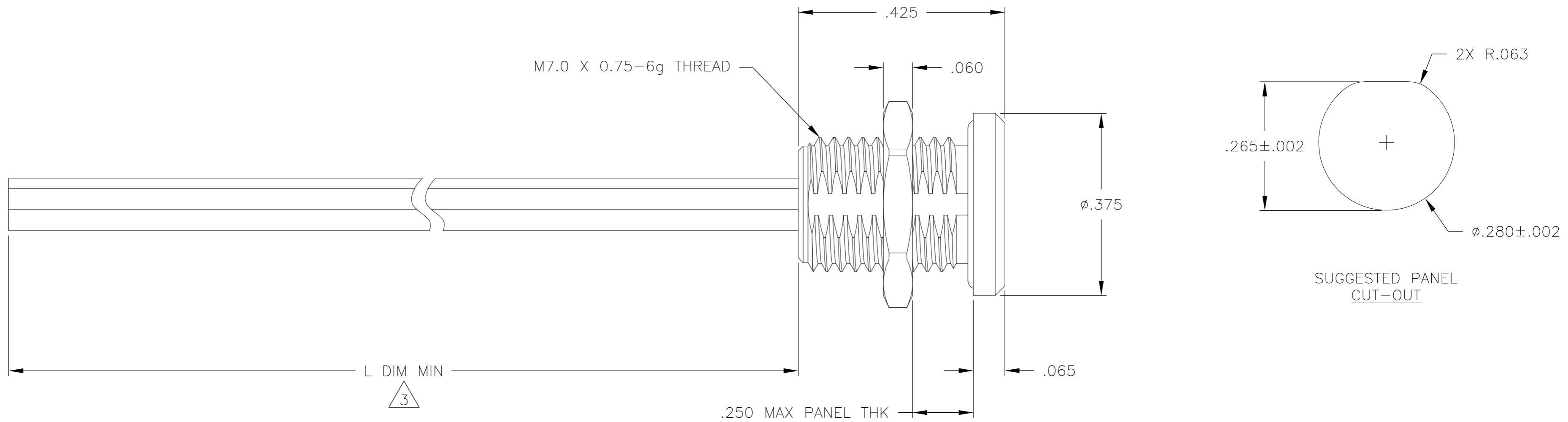

- 1 CONNECTOR BODY AND JAM NUT MATERIAL:
6061-T6 ALUMINUM, ELECTROLESS NICKEL PLATED PER SAE-AMS-C-26074 OR SAE-AMS-2404
INSULATOR MATERIAL: LIQUID CRYSTAL POLYMER (LCP) PER ASTM D5138
O-RING MATERIAL: FLUOROSILICONE PER SAE-AMS-R-25988
- 2 TERMINATED WITH MADISON CABLE 30 AWG 10G TURBO TWIN PAIR
- 3 CABLE LENGTH IS AS INDICATED IN THE CORRESPONDING NANONICS PART NUMBER
- 4 CAVITY POSITIONS ARE SHOWN FOR REFERENCE ONLY AND ARE NOT MARKED ON THE PART
- 5 LUBRICATE O-RING WITH PARKER SUPER-O-LUBE PRIOR TO INSTALLATION
- 6 REFERENCE TE PRODUCT SPECIFICATION 108-32048 FOR PRODUCT DETAILS AND PERFORMANCE

THIS DRAWING IS A CONTROLLED DOCUMENT.		DWN	M STORRY	2 AUG 2012		TE Connectivity			
DIMENSIONS: INCHES		CHK	M STORRY	2 AUG 2012		NAME			
TOLERANCES UNLESS OTHERWISE SPECIFIED:		APVD	M STORRY	2 AUG 2012		RECEPTACLE ASSEMBLY, CIRCULAR, FRONT FLUSH MOUNT, QUICK DISCONNECT, METAL, 8 POS, 10GbE, CeeLok FAS-T Nano Circular			
0 PLC ± - 1 PLC ± - 2 PLC ± .010 3 PLC ± .005 4 PLC ± - ANGLES ± 1°		PRODUCT SPEC	SIZE			CAGE CODE	DRAWING NO		
MATERIAL SEE NOTES		FINISH	SEE NOTES			WEIGHT	-	RESTRICTED TO	
		CUSTOMER DRAWING		SCALE	6:1	SHEET	1 of 1	REV	A