

PART NUMBER	REVISION	DESCRIPTION	FEED TYPE
2151025-1	F	FINE CRIMP HEIGHT ADJUST	MECHANICAL
2151025-2	F	FINE CRIMP HEIGHT ADJUST	PNEUMATIC
7-2151025-1	F	MECHANICAL AND CRIMP TOOLING KIT	MECHANICAL
7-2151025-2	F	PNEUMATIC AND CRIMP TOOLING KIT	PNEUMATIC
7-2151025-7	B	CRIMP TOOLING KIT	-

ATLANTIC VERSION TERMINATOR INTERFACE ADAPTER

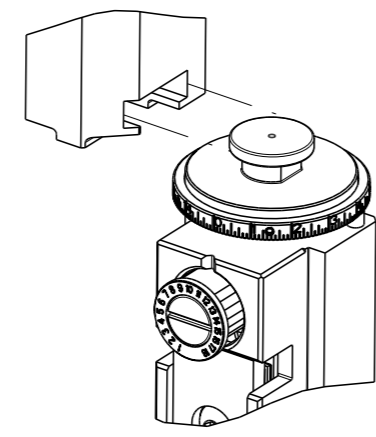

APPLICATOR DATA		
CRIMP	SIZE	TYPE
WIRE	2.29 mm [.090]	F
INSUL	5.08 mm [.200]	F

APPLICATOR INSTRUCTIONS 408-35042

TERMINAL DATA: TE TERMINAL TE CRIMP SPECIFICATION

TERMINAL NAME: PIN AND SOCKET UNIVERSAL MATE-N-LOK

WIRE STRIP LENGTH	INSULATION DIAMETER RANGE
3.99-4.75 mm [.157-.187 IN]	Ø3.30-5.08 mm [.130-.200 IN]

TERMINAL APPLICATION SPECIFICATION	114-1010

TERMINALS APPLIED

TE TERMINAL	TE TERMINAL	TE TERMINAL	TE TERMINAL
350537-1	350537-7	350538-3	350700-2
350537-2	1-350537-2	350538-6	350700-3
350537-3	350538-1	350538-7	350700-7
350537-6	350538-2	350700-1	1-350700-1
			2238103-1

WIRE SIZE	CRIMP HEIGHT mm [INCH]	CRIMP HEIGHT REFERENCE SETTING
14 AWG	1.75+/-0.05 [1.069+/-0.002]	4.1
DOUBLE 2@18AWG	1.60+/-0.05 [1.063+/-0.002]	5.7
1.50mm2	1.52+/-0.05 [1.060+/-0.002]	6.5
16 AWG	1.50+/-0.05 [1.059+/-0.002]	6.7
1.00mm2	1.42+/-0.05 [1.056+/-0.002]	7.5
18 AWG	1.32+/-0.05 [1.052+/-0.002]	8.6
20 AWG	1.19+/-0.05 [1.047+/-0.002]	10.0

- 1 RECOMMENDED SPARE PARTS
- 2 REFER TO SUPPLIED INSTRUCTION SHEET FOR CLEANING, LUBRICATION AND STORAGE OF APPLICATOR.
- 3 APPLY PART NUMBER 2-23419-6 LOCTITE TO THREADS OF ITEM 242.
- 4 CRIMP HEIGHT REFERENCE SETTING WAS THE SETTING USED WHEN THE APPLICATOR WAS QUALIFIED AT THE FACTORY. ADJUSTMENT MAY BE NECESSARY WHEN RUNNING APPLICATOR IN THE FIELD.
- 5. UNLESS SPECIFIED OTHERWISE TORQUE VALUES SHALL BE USED PER DOCUMENT, 101-35000.

***WARNING**
ON INSTALLATION, SET WIRE DISC TO CRIMP HEIGHT REFERENCE SETTING FOR LARGEST WIRE SIZE. CRIMP HEIGHT REFERENCE SETTINGS GREATER THAN THE VALUE SHOWN MAY CAUSE DAMAGE TO THE CRIMP TOOLING, REFER TO THE INSTRUCTION SHEET FOR PROPER SETUP AND ADJUSTMENTS.

LOC	DIST	REVISIONS			
A	66	REV	DATE	BY	CHK
		E	31JUL2019	MZ	YY
		E1	22JAN2020	TB	TE
		F	23MAR2020	JWC	RK
		F1	01APR2020	JWC	RK

-	1	-	1	-	2119641-1	FEED CAM, AIR FEED	248
-	1	1	1	1	2119082-9	CAM, SNAIL, INSULATION ADJUSTMENT	244
-	1	1	1	1	2079764-1	WASHER, WAVE SPRING, CREST-TO-CREST	243
-	1	1	1	1	2119083-1	RETAINER, INSULATION DIAL	242
-	1	1	1	1	18023-1	SCR, SKT HD CAP M3 X 5.0	241
-	-	1	-	1	2119580-1	MECHANICAL FEED ASSEMBLY	239
-	1	-	1	-	2844940-1	AIR FEED MODULE	238
-	REF	REF	REF	REF	994970-2	COUNTER, MAGNETIC	164
-	1	1	1	1	2844908-1	SCREW, LOCKING	99
-	1	1	1	1	2844907-1	POST, LOCKING	98
-	1	1	1	1	455888-6	SPACER, CRIMPER	82
-	1	1	1	1	22278-9	SPRING, COMPRESSION	77
-	1	1	1	1	854769-2	HOLDER, INS	74
-	1	1	1	1	1803607-3	DOCUMENTATION PACKAGE	71
-	1	1	1	1	2119740-1	TAG, IDENTIFICATION	67
-	2	2	2	2	2168078-1	SCREW, DRIVE, RH, RoHS, 2 x .188	66
-	1	1	1	1	2168083-2	SCR, SKT HD CAP, RoHS, M4 X 8.0	60
-	1	1	1	1	5-18022-5	SCR, HEX HD CAP, M4 X 6.0	59
-	1	1	1	1	21028-2	PIN, SLOTTED SPRING .062 X .250	58
-	1	1	1	1	1338685-1	PAWL, FEED	56
-	4	4	4	4	2168083-3	SCR, SKT HD CAP, RoHS, M4 X 12.0	54
-	2	2	2	2	2168083-3	SCR, SKT HD CAP, RoHS, M4 X 12.0	53
-	1	1	1	1	1803382-6	HOLD DOWN, SPRING LOADED	50
-	1	2	1	2	18023-9	SCR, SKT HD CAP M4 X 6.0	49
-	-	1	-	1	2119652-1	FEED CAM, PRE FEED	48
-	-	1	-	1	2119653-1	FEED CAM, POST FEED	47
-	1	1	1	1	1803583-9	APPLICATOR BASIC ASSEMBLY, SF	46
-	1	1	1	1	1803515-1	RAM ASSEMBLY, SF ATLANTIC	44
-	1	1	1	1	1803602-1	SCR, BHSC, RoHS (M8 X 25)	41
-	1	1	1	1	1752356-6	SUPPORT, TERMINAL	34
-	2	2	2	2	2079383-5	SCR, BHSC, RoHS (M4 X 20)	33
-	2	2	2	2	2-2844962-6	SPACER, CYLINDRICAL, STRIP GUIDE	30
-	1	1	1	1	2844992-1	ASSEMBLY, STRIP GUIDE	29
-	1	1	1	1	1-455888-0	SPACER, CRIMPER	28
-	1	1	1	1	1320928-2	STRIP GUIDE	24
-	1	1	1	1	2168083-2	SCR, SKT HD CAP, RoHS, M4 X 8.0	21
-	2	2	2	2	1-18028-2	WASHER, FLAT, REG M4	20
-	1	1	1	1	2119533-1	STRIPPER, SIDE FEED	19
-	1	1	1	1	2119806-1	INSERT, SHEAR	13
-	1	1	1	1	3-22280-3	SPRING, COMPRESSION	12
-	1	1	1	1	1-356885-4	STOP, SHEAR	11
-	1	1	1	1	2119805-1	SHEAR HOLDER, FRONT	10
-	1	1	1	1	462006-6	FLOATING SHEAR, FRONT	9
-	1	2	2	1	1-1333205-1	ANVIL, COMBINATION	8
-	1	1	1	1	240641-5	SPACER	7
-	1	1	1	1	1-2119780-4	DEPRESSOR, SHEAR	5
-	1	1	1	1	238011-4	BLOCK, CRIMPER SPACER	4
-	1	2	2	1	5-1803016-4	CRIMPER, INSULATION F	3
-	1	1	1	1	455888-3	SPACER, CRIMPER	2
-	1	2	2	1	8-456406-1	CRIMPER, WIRE PREMIUM	1

ATLANTIC VERSION
Shown on sheets 1 of 4 & 2 of 4
(Pacific version shown on sheets 3 of 4 & 4 of 4)

DIMENSIONS:		TOLERANCES UNLESS OTHERWISE SPECIFIED:		MATERIAL:		FINISH:		WEIGHT:		SCALE:	
mm	0 PLC	±									
	1 PLC	±									
	2 PLC	±									
	3 PLC	±									
	4 PLC	±									
	ANGLES	±									

LOC		DIST		REVISIONS			
A	66	P	LYR	DESCRIPTION	DATE	OWN	APVD
		-		SEE SHEET 1			

FEED TYPE MECHANICAL

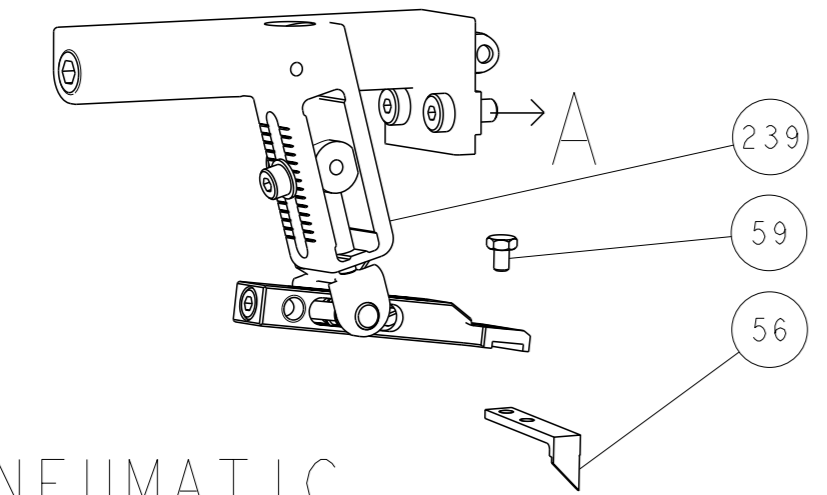

PNEUMATIC

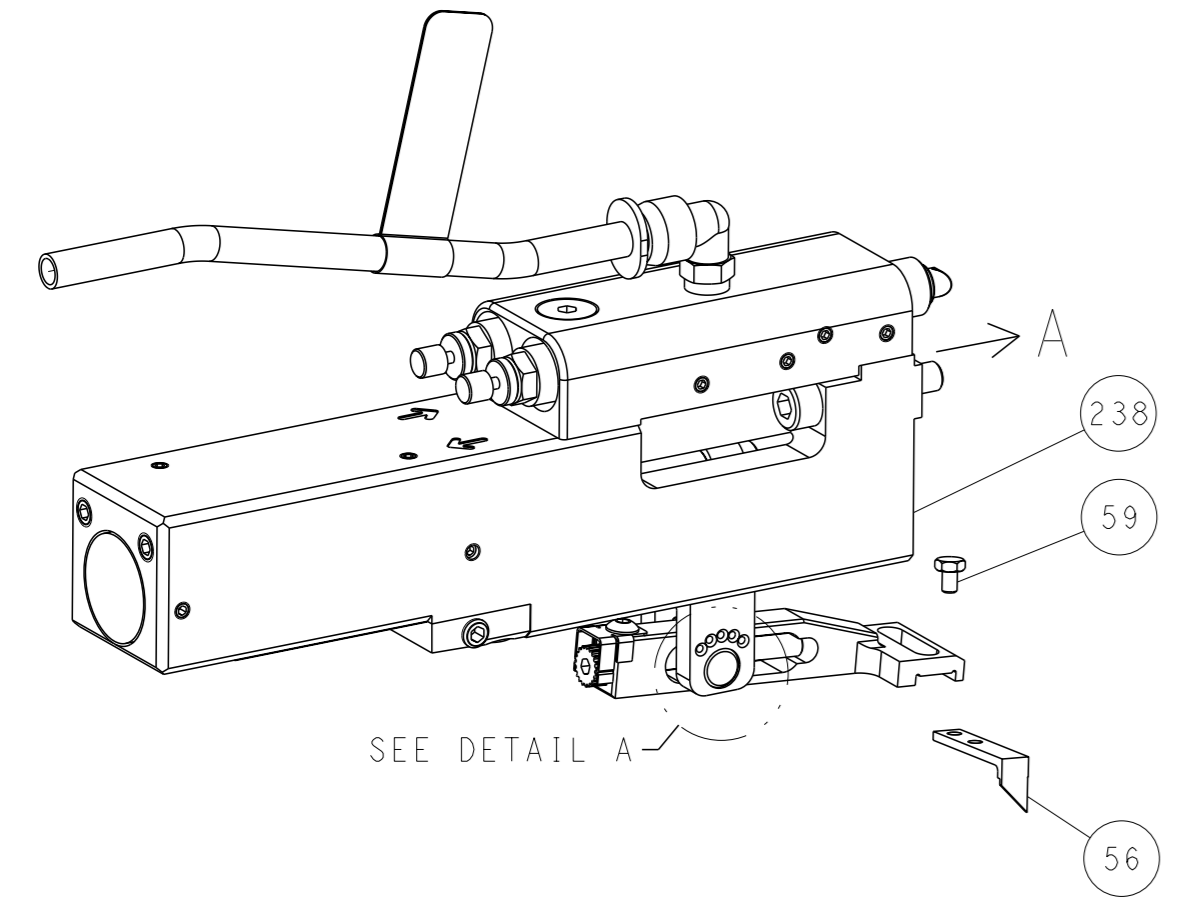

FEED SPRING SETTING POSITION (SHOWN FROM REAR SIDE)

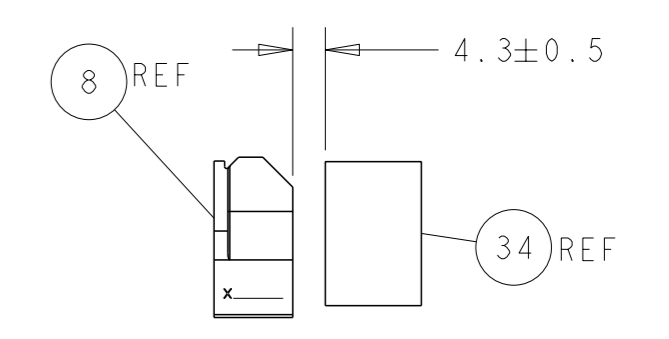
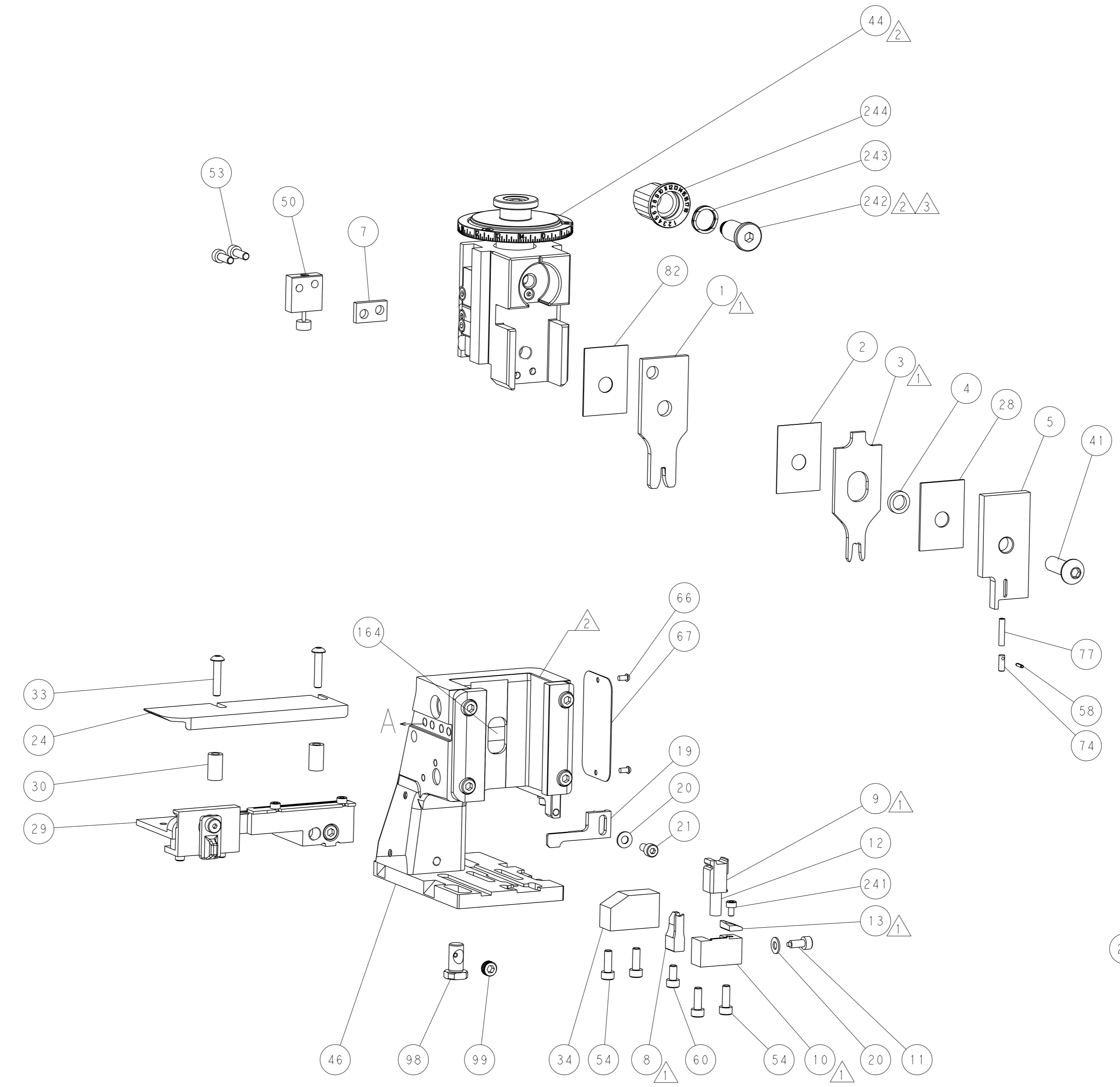
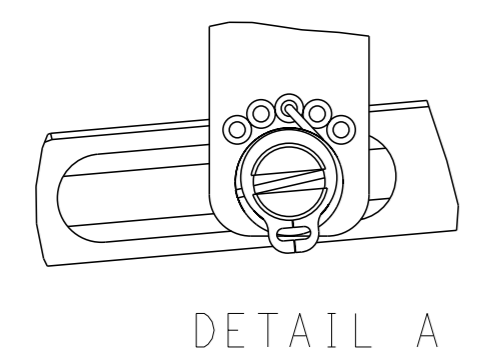

TERMINAL SUPPORT LOCATION

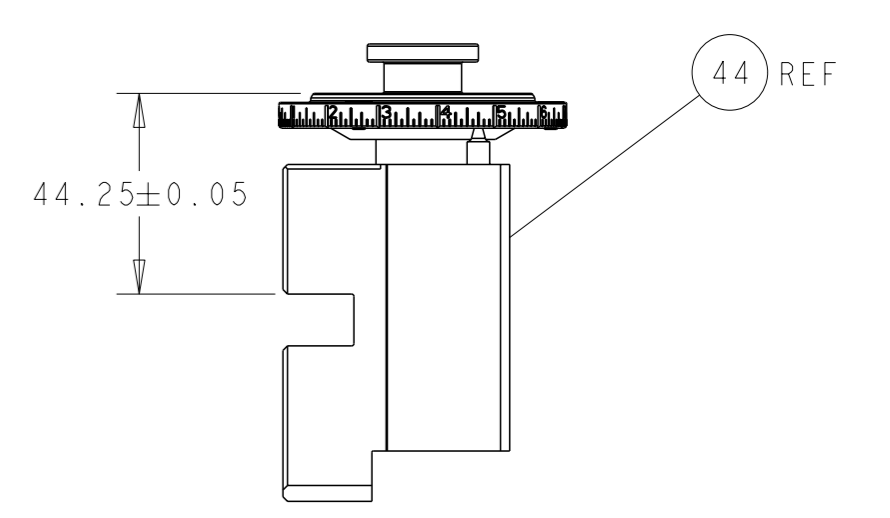

RAM SET-UP

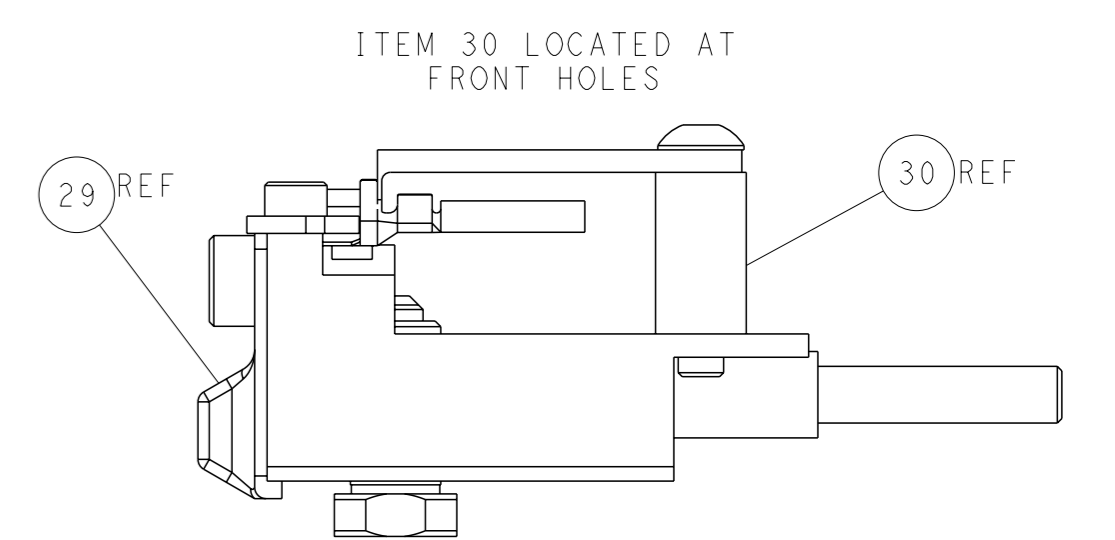

FEED TRACK POSITION GUIDE BY INSULATION BARREL

CAM POSITIONS

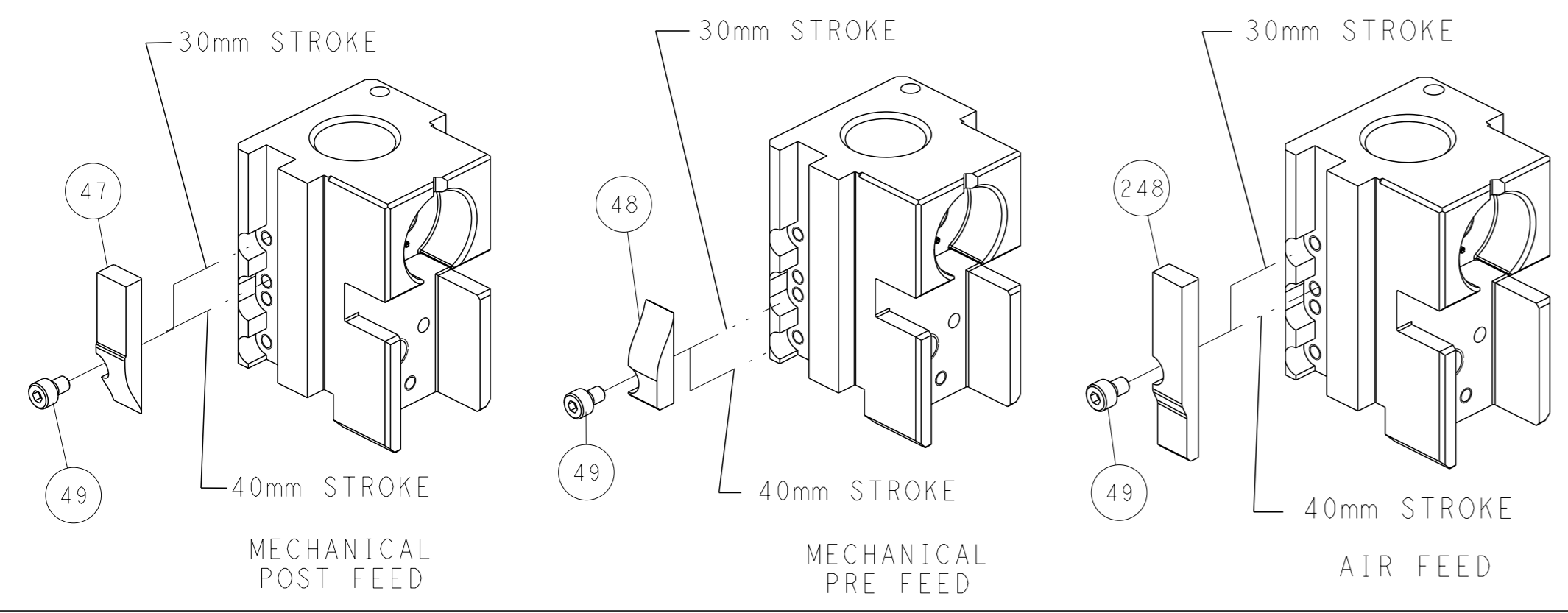

ATLANTIC VERSION
 Shown on sheets 1 of 4 & 2 of 4
 (Pacific version shown on sheets 3 of 4 & 4 of 4)

<small>THIS DRAWING IS A CONTROLLED DOCUMENT FOR TYCO ELECTRONICS CORPORATION. IT IS SUBJECT TO CHANGE AND TO CONTROLING ENGINEERING DISCRETION. SHOULD BE CONTACTED FOR THE LATEST REVISION.</small>		OWN: R. STAKEM 10OCT2011 CHK: G. BAILEY 10OCT2011 APVD: J. ELBIN 10OCT2011	NAME: Ocean Side Feed Applicator SIZE: A1 CAGE CODE: 00779 DRAWING NO: 2151025 RESTRICTED TO: -
DIMENSIONS: mm TOLERANCES UNLESS OTHERWISE SPECIFIED: 0 PLC ± 1 PLC ± 2 PLC ± 3 PLC ± 4 PLC ± ANGLES FINISH ±	WEIGHT: - SCALE: 1:2 SHEET: 2 of 4 REV: F1	TE Connectivity Harrisburg, PA 17105-3608 Customer Accessible Production Drawing	

THIS DRAWING IS UNPUBLISHED. RELEASED FOR PUBLICATION 20
 BY TYCO ELECTRONICS CORPORATION. ALL RIGHTS RESERVED.

PART NUMBER	REVISION	DESCRIPTION	FEED TYPE
2-2151025-1	F	FINE CRIMP HEIGHT ADJUST	MECHANICAL
2-2151025-2	F	FINE CRIMP HEIGHT ADJUST	PNEUMATIC
7-2151025-7	B	CRIMP TOOLING KIT	-

PACIFIC VERSION TERMINATOR
 INTERFACE ADAPTER

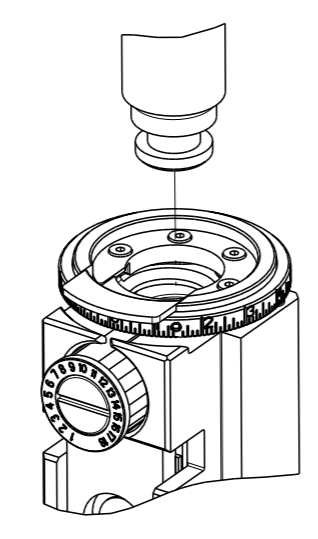

APPLICATOR DATA		
CRIMP	SIZE	TYPE
WIRE	2.29 mm [.090]	F
INSUL	5.08 mm [.200]	F
APPLICATOR INSTRUCTIONS 408-35042		

TERMINAL DATA: TE TERMINAL TE CRIMP SPECIFICATION

TERMINAL NAME: PIN AND SOCKET UNIVERSAL MATE-N-LOK	
WIRE STRIP LENGTH 3.99-4.75 mm [1.57-.187 IN]	INSULATION DIAMETER RANGE Ø3.30-5.08 mm [1.130-.200 IN]
TERMINAL APPLICATION SPECIFICATION 114-1010	

TERMINALS APPLIED			
TE TERMINAL	TE TERMINAL	TE TERMINAL	TE TERMINAL
350537-1	350537-7	350538-3	350700-2
350537-2	1-350537-2	350538-6	350700-3
350537-3	350538-1	350538-7	350700-7
350537-6	350538-2	350700-1	1-350700-1
			2238103-1

WIRE SIZE	CRIMP HEIGHT mm [INCH]	CRIMP HEIGHT REFERENCE SETTING
14 AWG	1.75+/-0.05 [1.069+/-0.002]	4.1
DOUBLE 2@18AWG	1.60+/-0.05 [1.063+/-0.002]	5.7
1.50mm2	1.52+/-0.05 [1.060+/-0.002]	6.5
16 AWG	1.50+/-0.05 [1.059+/-0.002]	6.7
1.00mm2	1.42+/-0.05 [1.056+/-0.002]	7.5
18 AWG	1.32+/-0.05 [1.052+/-0.002]	8.6
20 AWG	1.19+/-0.05 [1.047+/-0.002]	10.0

***WARNING**
 ON INSTALLATION, SET WIRE DISC TO CRIMP HEIGHT REFERENCE SETTING FOR LARGEST WIRE SIZE. CRIMP HEIGHT REFERENCE SETTINGS GREATER THAN THE VALUE SHOWN MAY CAUSE DAMAGE TO THE CRIMP TOOLING, REFER TO THE INSTRUCTION SHEET FOR PROPER SETUP AND ADJUSTMENTS.

- 1 RECOMMENDED SPARE PARTS
- 2 REFER TO SUPPLIED INSTRUCTION SHEET FOR CLEANING, LUBRICATION AND STORAGE OF APPLICATOR.
- 3 APPLY PART NUMBER 2-23419-6 LOCTITE TO THREADS OF ITEM 242.
- 4 CRIMP HEIGHT REFERENCE SETTING WAS THE SETTING USED WHEN THE APPLICATOR WAS QUALIFIED AT THE FACTORY. ADJUSTMENT MAY BE NECESSARY WHEN RUNNING APPLICATOR IN THE FIELD.
- 5. UNLESS SPECIFIED OTHERWISE TORQUE VALUES SHALL BE USED PER DOCUMENT, 101-35000.

LOC	DIST	REVISIONS			
A	66	REV	DATE	BY	APPV
		-	SEE SHEET 1	-	-

-	1	1	2119082-9	CAM, SNAIL, INSULATION ADJUSTMENT	244	
-	1	1	2079764-1	WASHER, WAVE SPRING, CREST-TO-CREST	243	
3	-	1	1	2119083-1	RETAINER, INSULATION DIAL	242
-	-	1	1	18023-1	SCR, SKT HD CAP M3 X 5.0	241
-	-	1	1	2119580-1	MECHANICAL FEED ASSEMBLY	239
-	1	-	1	2844940-1	AIR FEED MODULE	238
-	REF	REF	1	994970-2	COUNTER, MAGNETIC	164
-	1	-	1	2119641-2	FEED CAM, AIR FEED	151
-	1	1	1	2168083-8	SCR, SKT HD CAP, RoHS, M4 X 16	144
-	4	4	1	2168083-9	SCR, SKT HD CAP, RoHS, M4 X 20	143
-	-	1	1	2119653-2	FEED CAM, POST FEED	142
-	1	1	1	1-1803583-0	APPLICATOR BASIC ASSEMBLY, SF	141
-	1	1	1	1803516-1	RAM ASSEMBLY, SF PACIFIC	140
-	1	1	1	2844908-1	SCREW, LOCKING	99
-	1	1	1	2844907-1	POST, LOCKING	98
-	1	1	1	455888-6	SPACER, CRIMPER	82
-	1	1	1	22278-9	SPRING, COMPRESSION	77
-	1	1	1	854769-2	HOLDER, INS	74
-	1	1	1	1803607-3	DOCUMENTATION PACKAGE	71
-	1	1	1	2119740-1	TAG, IDENTIFICATION	67
-	2	2	1	2168078-1	SCREW, DRIVE, RH, RoHS, 2 x .188	66
-	1	1	1	5-18022-5	SCR, HEX HD CAP, M4 X 6.0	59
-	1	1	1	21028-2	PIN, SLOTTED SPRING .062 X .250	58
-	1	1	1	1338685-1	PAWL, FEED	56
-	2	2	1	2168083-3	SCR, SKT HD CAP, RoHS, M4 X 12.0	53
-	1	1	1	1803382-6	HOLD DOWN, SPRING LOADED	50
-	1	2	1	18023-9	SCR, SKT HD CAP M4 X 6.0	49
-	-	1	1	2119652-1	FEED CAM, PRE FEED	48
-	1	1	1	1803602-1	SCR, BHSC, RoHS (M8 X 25)	41
-	1	1	1	1752356-6	SUPPORT, TERMINAL	34
-	2	2	1	2079383-5	SCR, BHSC, RoHS (M4 X 20)	33
-	2	2	1	2-2844962-6	SPACER, CYLINDRICAL, STRIP GUIDE	30
-	1	1	1	2844992-1	ASSEMBLY, STRIP GUIDE	29
-	1	1	1	1-455888-0	SPACER, CRIMPER	28
-	1	1	1	1320928-2	STRIP GUIDE	24
-	1	1	1	2168083-2	SCR, SKT HD CAP, RoHS, M4 X 8.0	21
-	2	2	1	1-18028-2	WASHER, FLAT, REG M4	20
-	1	1	1	2119533-1	STRIPPER, SIDE FEED	19
1	-	1	1	2119806-1	INSERT, SHEAR	13
-	1	1	1	3-22280-3	SPRING, COMPRESSION	12
-	1	1	1	1-356885-4	STOP, SHEAR	11
-	1	1	1	2119805-1	SHEAR HOLDER, FRONT	10
1	-	1	1	462006-6	FLOATING SHEAR, FRONT	9
1	1	1	1	1-1333205-1	ANVIL, COMBINATION	8
-	1	1	1	240641-5	SPACER	7
-	1	1	1	1-2119780-4	DEPRESSOR, SHEAR	5
-	1	1	1	238011-4	BLOCK, CRIMPER SPACER	4
1	1	1	1	5-1803016-4	CRIMPER, INSULATION F	3
-	1	1	1	455888-3	SPACER, CRIMPER	2
1	1	1	1	8-456406-1	CRIMPER, WIRE PREMIUM	1
-77	-22	-21		PART NO	DESCRIPTION	ITEM NO

PACIFIC VERSION
 Shown on sheets 3 of 4 & 4 of 4
 (Atlantic version shown on sheets 1 of 4 & 2 of 4)

DIMENSIONS: mm 		TOLERANCES UNLESS OTHERWISE SPECIFIED: 0 PLC ± 1 PLC ± 2 PLC ± 3 PLC ± 4 PLC ± ANGLES FINISH ±		OWN: H. STAKEM 10OCT2011 CHK: G. BAILEY 10OCT2011 APVD: J. ELBIN 10OCT2011 PRODUCT SPEC APPLICATION SPEC		NAME: TE Connectivity Ocean Side Feed Applicator Harrisburg, PA 17105-3608	
MATERIAL:		WEIGHT:		SCALE: 1:2		SHEET 3 OF 4	
Customer Accessible Production Drawing		00779		©=2151025		REV F1	

REVISONS		DATE	OWN	APVD
P	LYH			
- SEE SHEET 1				

FEED TYPE MECHANICAL

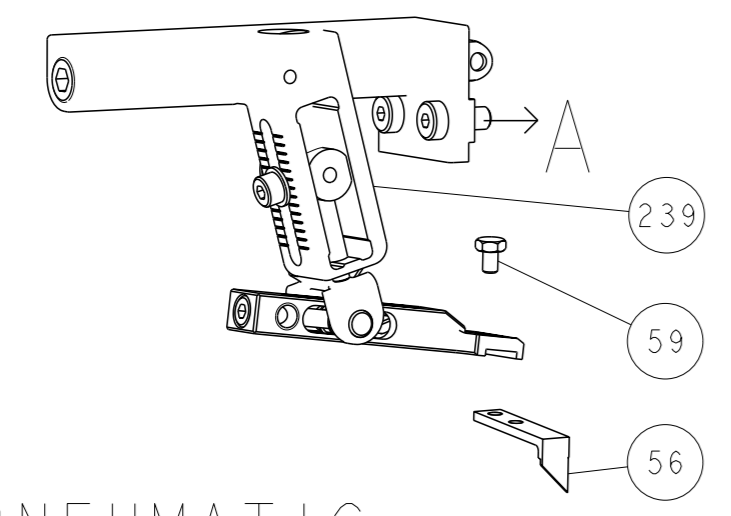

PNEUMATIC

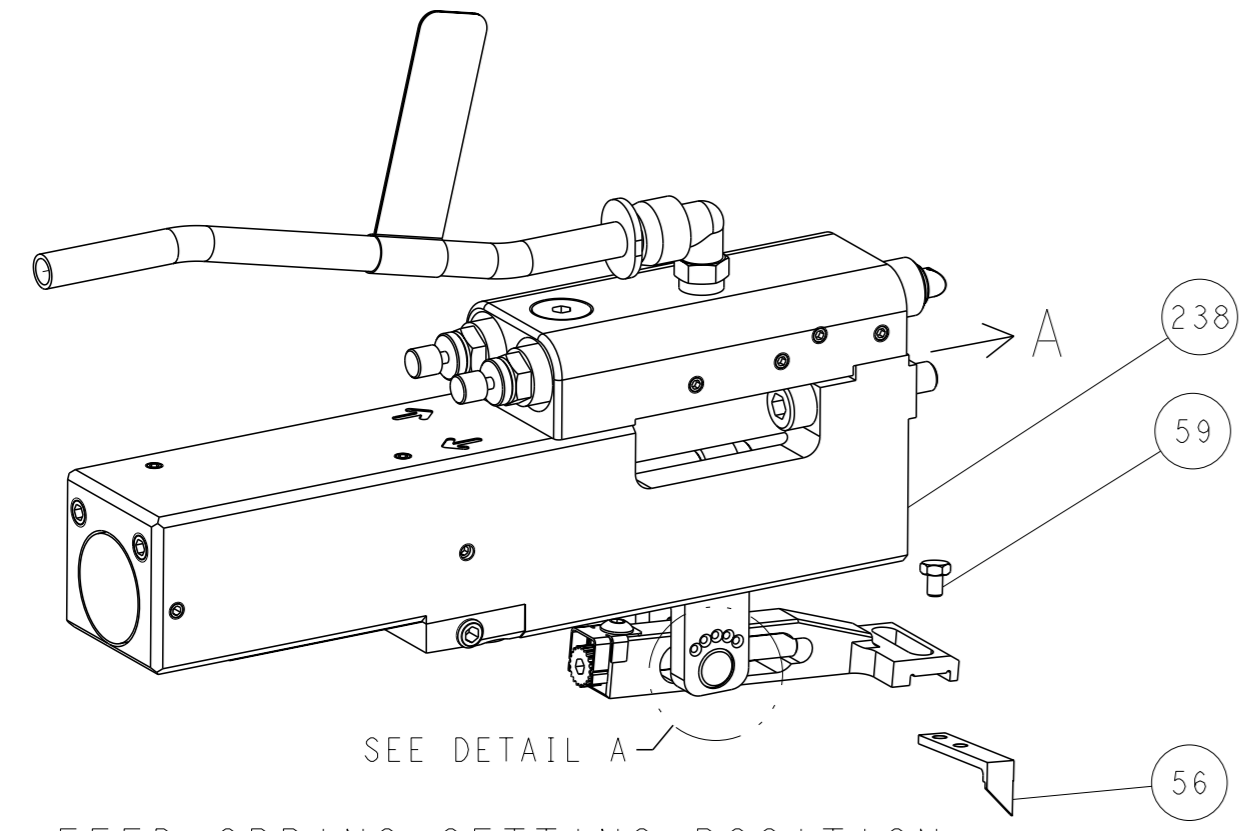

FEED SPRING SETTING POSITION
(SHOWN FROM REAR SIDE)

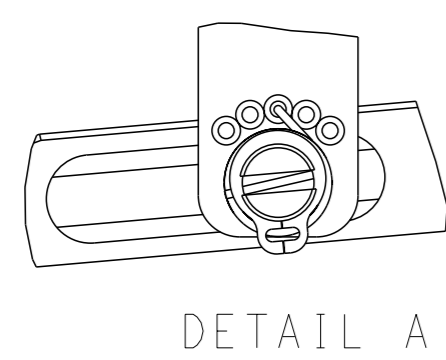

DETAIL A

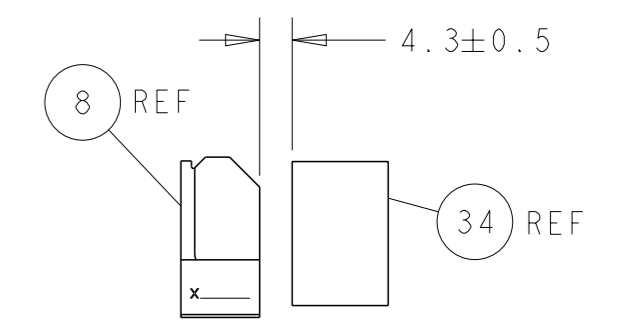
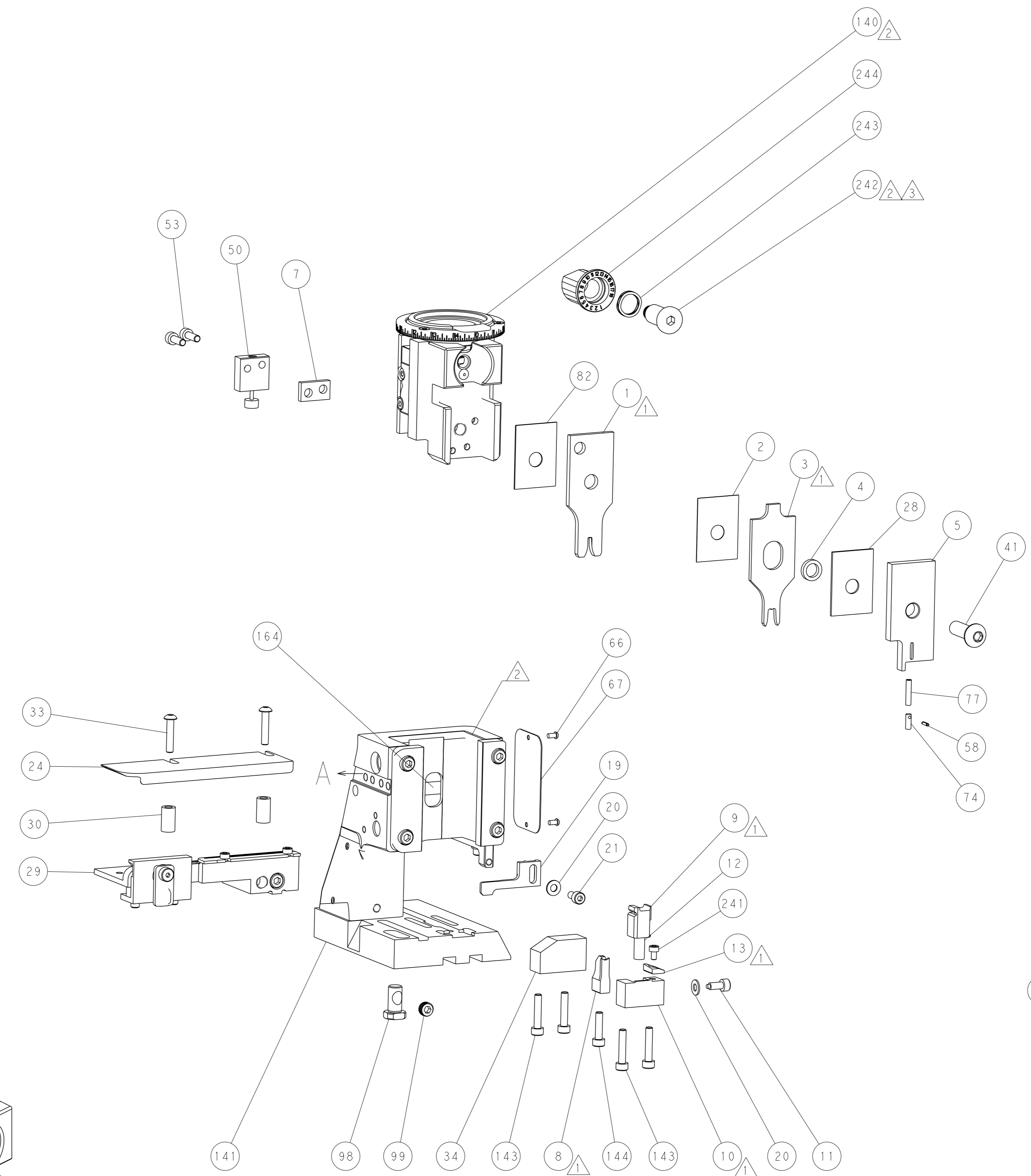

TERMINAL SUPPORT LOCATION

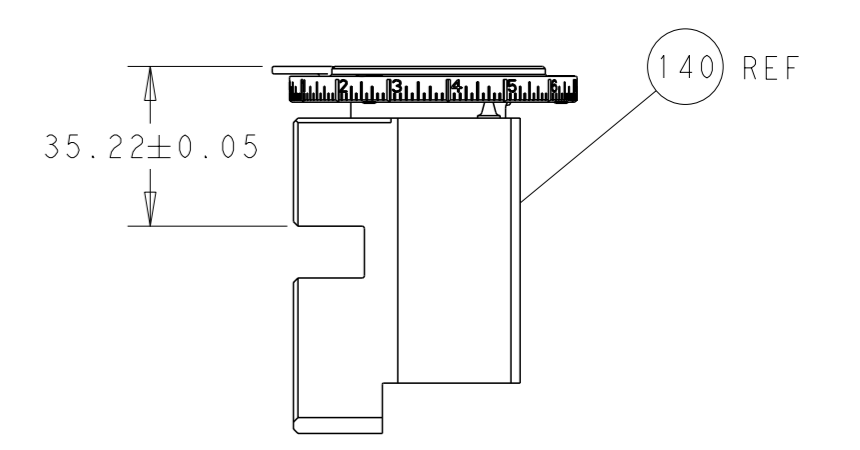

RAM SET-UP

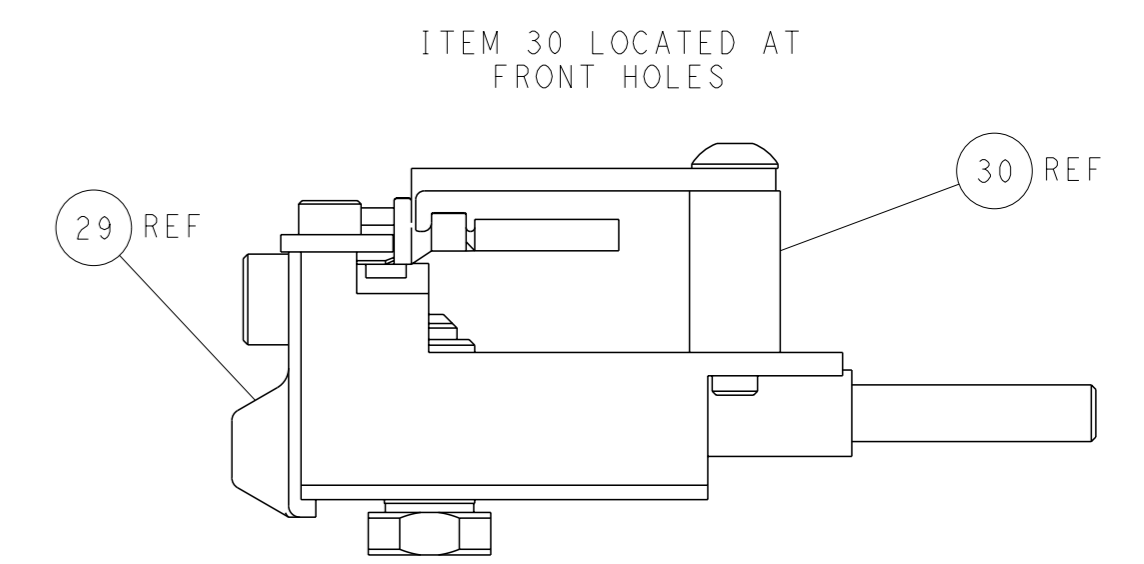

FEED TRACK POSITION
GUIDE BY INSULATION BARREL

CAM POSITIONS

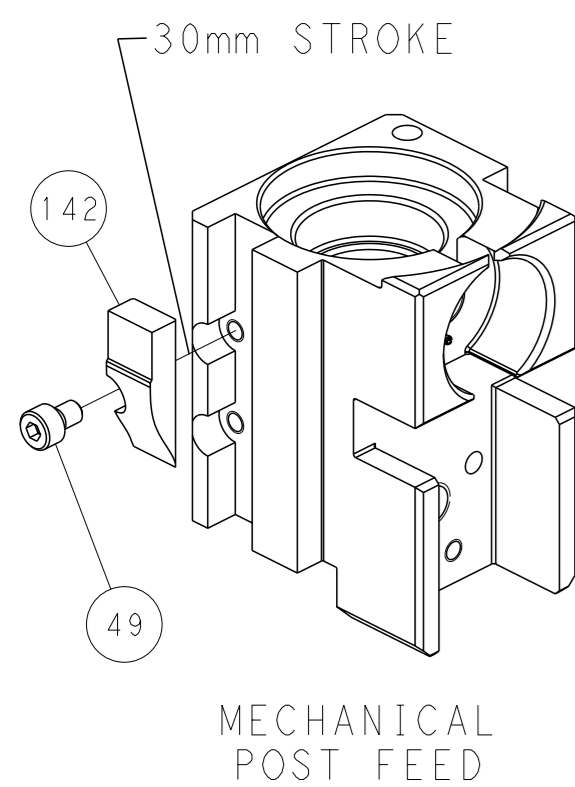

MECHANICAL
POST FEED

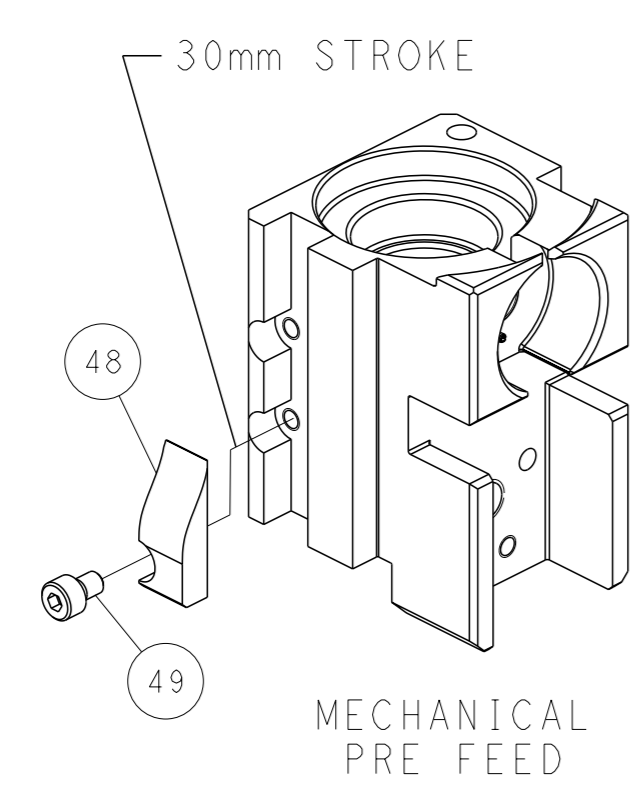

MECHANICAL
PRE FEED

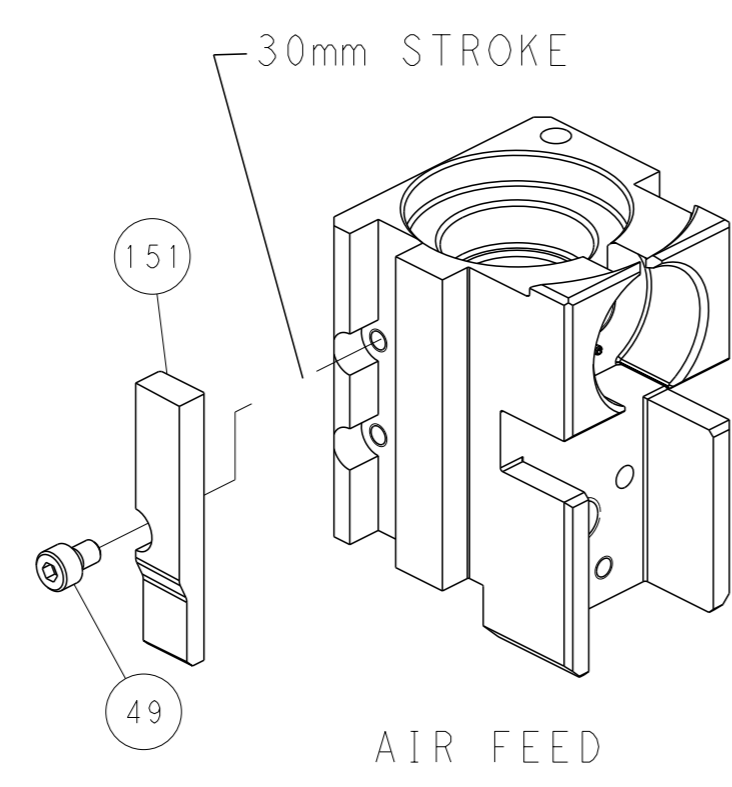

AIR FEED

PACIFIC VERSION
 Shown on sheets 3 of 4 & 4 of 4
 (Atlantic version shown on sheets 1 of 4 & 2 of 4)

<small>THIS DRAWING IS A CONTROLLED DOCUMENT FOR TYCO ELECTRONICS CORPORATION. IT IS SUBJECT TO CHANGE AND THE USER'S RESPONSIBILITY TO OBTAIN THE LATEST REVISION SHOULD BE CONTACTED FOR THE LATEST REVISION.</small>		OWN: H. STAKEM CHK: G. BAILEY APVD: J. ELBIN PRODUCT SPEC: - APPLICATION SPEC: - MATERIAL: - WEIGHT: - FINISH: -	100CT2011 100CT2011 100CT2011 NAME: Ocean Side Feed Applicator SIZE: A1 CAGE CODE: 00779 DRAWING NO: 2151025 SCALE: 1:2 SHEET: 4 of 4 REV: F1	TE Connectivity Harrisburg, PA 17105-3608
---	--	---	--	--