

Industrial digital output expansion board based on IPS8160HQ for STM32 Nucleo

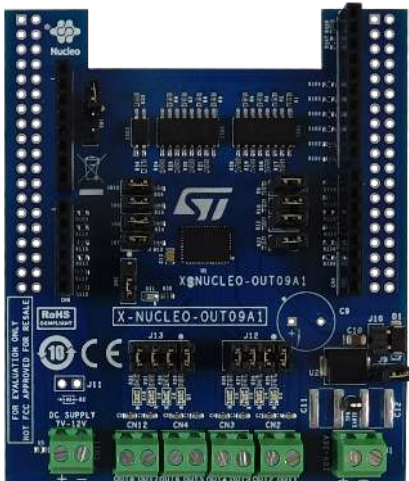

Features

- Based on the [IPS8160HQ](#) octal high-side switch, which features:
 - Operating range 10.5 to 36 V
 - Low power dissipation ($R_{ON(MAX)} = 280\text{ m}\Omega$)
 - Fast decay for inductive loads
 - Undervoltage lock-out
 - Overload and overtemperature protections
 - Loss of ground protection
 - QFN48L 8x6 mm package
- Application board voltage operating range: 15 to 33 V
- Extended voltage operating range (J9 open) up to 36 V
- Operating current: up to 0.7 A per channel
- Green LEDs for outputs on/off status (J12 and J13 close 1-2, 3-4, 5-6, 7-8)
- Red LED for common overheating diagnostic (SW2 close 2-3)
- 3 kV galvanic isolation
- Supply rail reverse polarity protection
- Compatible with [STM32 Nucleo](#) development boards
- Equipped with [Arduino® UNO R3](#) connectors
- RoHS and China RoHS compliant
- CE certified

Product summary

Industrial digital output expansion board based on IPS8160HQ for STM32 Nucleo	X-NUCLEO-OUT09A1
Software expansion for STM32Cube driving industrial digital output based on intelligent power switch (IPS)	X-CUBE-IPS
Octal high-side smart power solid-state relay	IPS8160HQ
Applications	Programmable Logic Controllers

Description

The [X-NUCLEO-OUT09A1](#) industrial digital output expansion board for [STM32 Nucleo](#) provides a powerful and flexible environment for the evaluation of the driving and diagnostic capabilities of the [IPS8160HQ](#) octal high-side smart power solid state relay, in a digital output module connected to 0.7 A industrial loads.

The [X-NUCLEO-OUT09A1](#) interfaces with the microcontroller on the [STM32 Nucleo](#) via 3 kV and 3.7 kV optocouplers driven by GPIO pins and [Arduino® R3](#) connectors. The expansion board can be connected to either a [NUCLEO-F401RE](#) or a [NUCLEO-G431RB](#) development board.

It is also possible to evaluate a system composed of a [X-NUCLEO-OUT09A1](#) stacked on other expansion boards.

1 Schematic diagrams

Figure 1. X-NUCLEO-OUT09A1 circuit schematic (1 of 2)

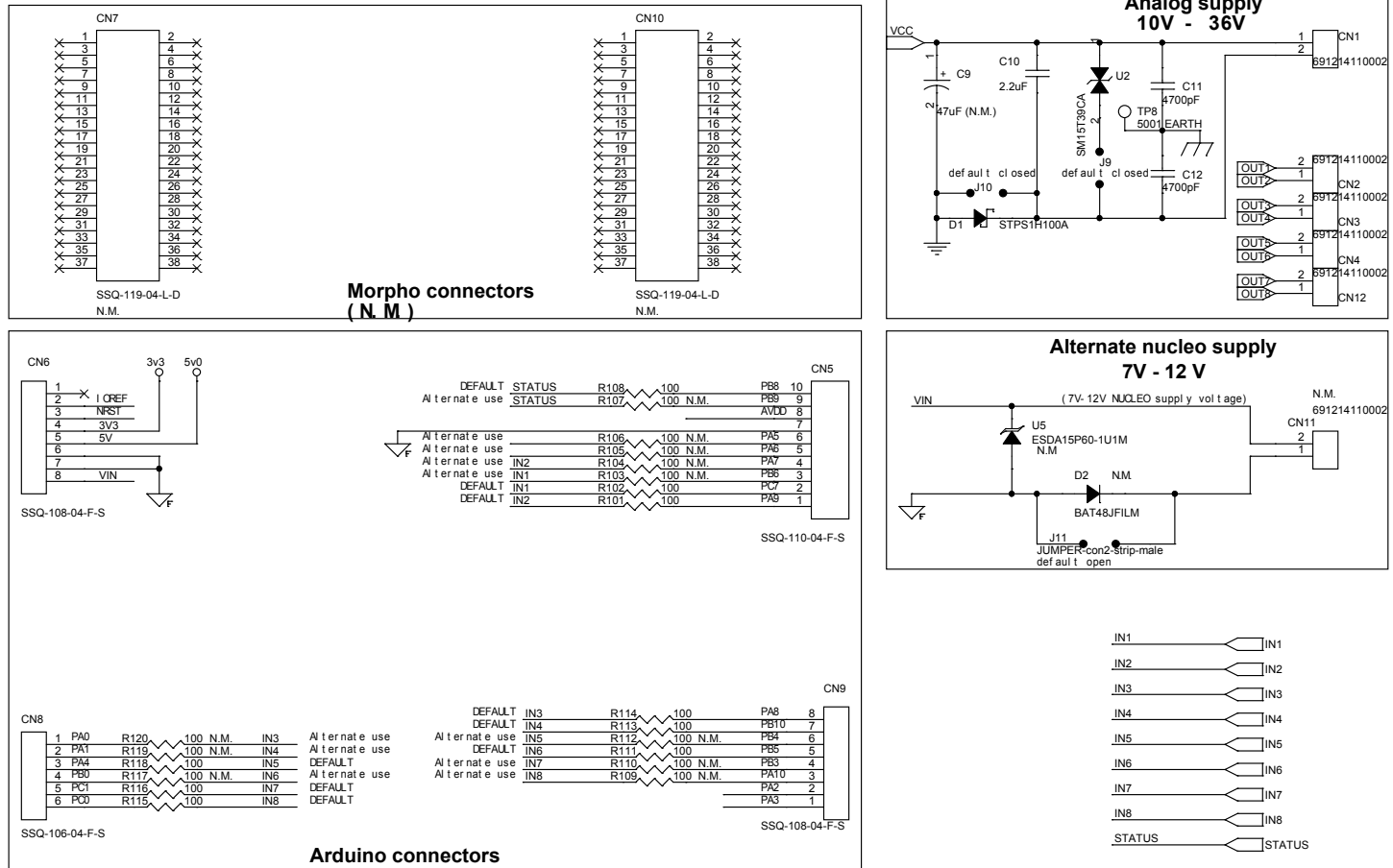
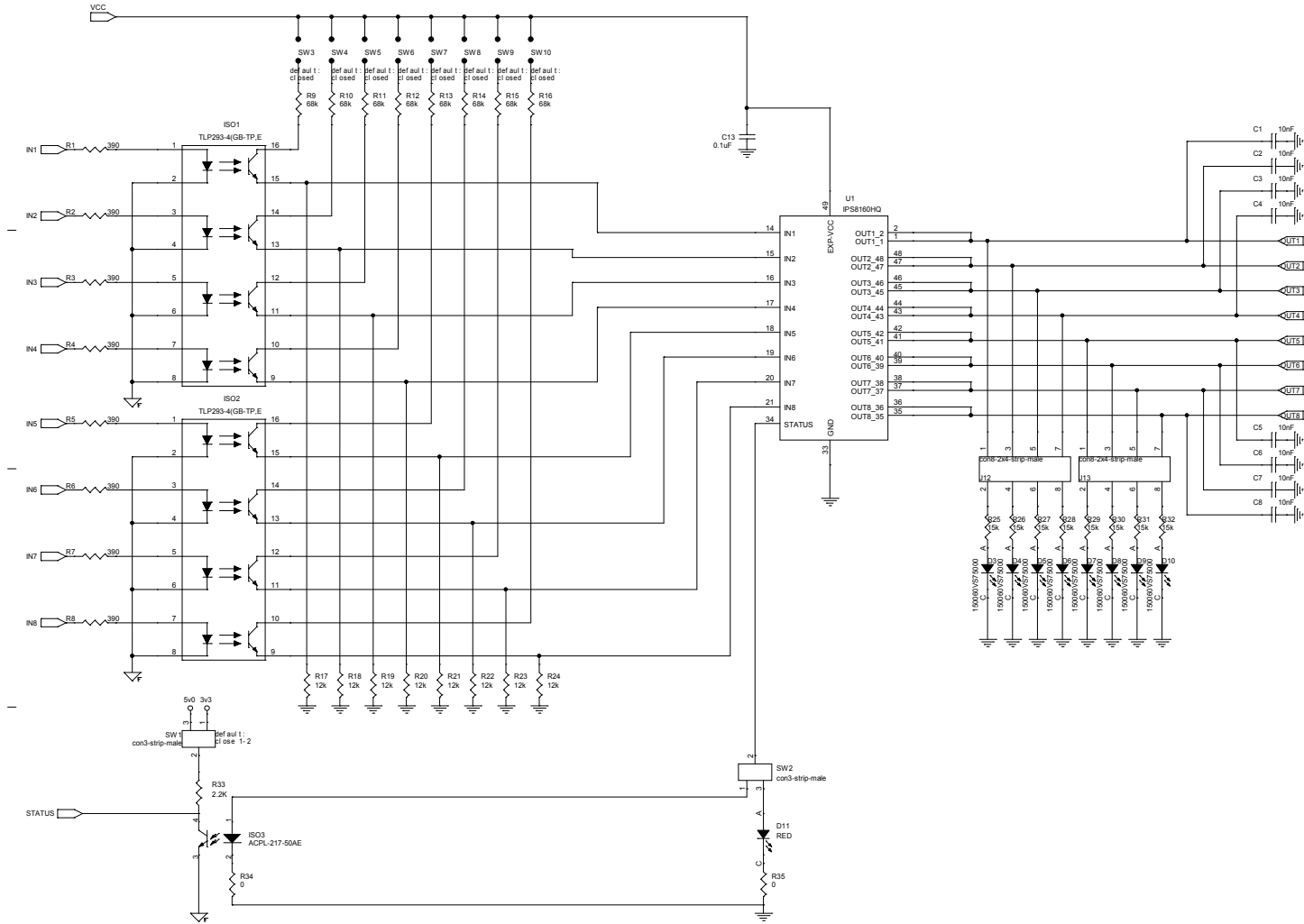

Figure 2. X-NUCLEO-OUT09A1 circuit schematic (2 of 2)



2 Board versions

Table 1. X-NUCLEO-OUT09A1 versions

Finished good	Schematic diagrams	Bill of materials
X\$NUCLEO-OUT09A1 ⁽¹⁾	X\$NUCLEO-OUT09A1 schematic diagrams	X\$NUCLEO-OUT09A1 bill of materials

1. This code identifies the X-NUCLEO-OUT09A1 evaluation board first version.

Revision history

Table 2. Document revision history

Date	Revision	Changes
14-Oct-2022	1	Initial release.

IMPORTANT NOTICE – READ CAREFULLY

STMicroelectronics NV and its subsidiaries (“ST”) reserve the right to make changes, corrections, enhancements, modifications, and improvements to ST products and/or to this document at any time without notice. Purchasers should obtain the latest relevant information on ST products before placing orders. ST products are sold pursuant to ST’s terms and conditions of sale in place at the time of order acknowledgment.

Purchasers are solely responsible for the choice, selection, and use of ST products and ST assumes no liability for application assistance or the design of purchasers’ products.

No license, express or implied, to any intellectual property right is granted by ST herein.

Resale of ST products with provisions different from the information set forth herein shall void any warranty granted by ST for such product.

ST and the ST logo are trademarks of ST. For additional information about ST trademarks, refer to www.st.com/trademarks. All other product or service names are the property of their respective owners.

Information in this document supersedes and replaces information previously supplied in any prior versions of this document.

© 2022 STMicroelectronics – All rights reserved