

### FEATURES

#### General

Low power HDMI transmitter ideal for portable applications  
CEC controller and expanded message buffer (3 messages)  
reduces system overhead

HDMI Version 1.4a features supported

3D video

Extended colorimetry

#### Compatible with DVI 1.0

Optional embedded HDCP keys to support HDCP 1.3

Video/audio inputs accept logic levels from 1.8 V to 3.3 V

#### Digital video

150 MHz operation supports all video and graphics  
resolutions from 480i to 1080p

Programmable 2-way color-space converter

Supports RGB, YCrCb, and DDR

Supports ITU656-based embedded syncs

Automatic input video format timing detection (CEA-861E)

#### Digital audio

Supports standard S/PDIF for stereo LPCM or compressed  
audio up to 192 kHz

2-channel, uncompressed LPCM I<sup>2</sup>S audio up to 192 kHz

#### Special features for easy system design

On-chip MPU with I<sup>2</sup>C master to perform EDID reading and  
HDCP operations; reports HDMI events through interrupts  
and registers

5 V tolerant I<sup>2</sup>C and HPD I/Os, no extra device needed

No audio master clock needed for supporting S/PDIF  
and I<sup>2</sup>S

Compatible with AD9394 HDMI companion chip

5 V generator for Hot Plug detection in portable applications

### APPLICATIONS

Cellular handsets

Digital video cameras

Digital still cameras

Personal media players

Gaming

DVD players and recorders

Digital set-top boxes

HDMI repeater

### FUNCTIONAL BLOCK DIAGRAM

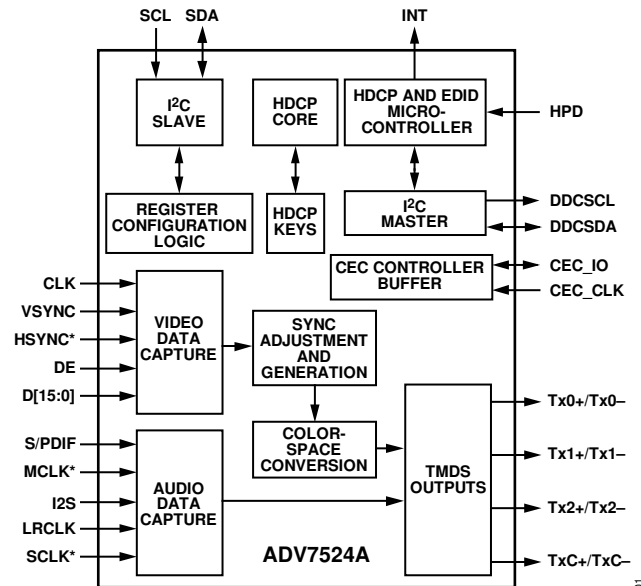

Figure 1.

### GENERAL DESCRIPTION

The ADV7524A is a 150 MHz, High-Definition Multimedia Interface (HDMI<sup>®</sup>) transmitter with expanded CEC buffer. It supports HDTV formats up to 1080p and computer graphic resolutions up to SXGA at 75 Hz.

With the optional inclusion of embedded HDCP keys, the ADV7524A allows the secure transmission of protected content, as specified by the HDCP 1.3 protocol.

The ADV7524A supports 3D video and extended colorimetry.

The ADV7524A supports both S/PDIF and 2-channel I<sup>2</sup>S audio. Its high fidelity, 2-channel I<sup>2</sup>S can transmit stereo up to a 192 kHz sampling rate. The S/PDIF can carry stereo LPCM audio or compressed audio including Dolby<sup>®</sup> digital and DTS<sup>®</sup>.

The ADV7524A helps to reduce system design complexity and cost by incorporating such features as an I<sup>2</sup>C master for EDID reading, and 5 V tolerance on the I<sup>2</sup>C and Hot Plug<sup>™</sup> detect pins.

Fabricated in an advanced CMOS process, the ADV7524A is available in a space saving, 49-ball, WLCSP surface-mount package. This package is RoHS compliant and specified to operate from -25°C to +85°C.

For more information on the ADV7524A, contact Analog Devices, Inc., at: [ATV\\_VideoTx\\_Apps@analog.com](mailto:ATV_VideoTx_Apps@analog.com).

Rev. SpB

[Document Feedback](#)

Information furnished by Analog Devices is believed to be accurate and reliable. However, no responsibility is assumed by Analog Devices for its use, nor for any infringements of patents or other rights of third parties that may result from its use. Specifications subject to change without notice. No license is granted by implication or otherwise under any patent or patent rights of Analog Devices. Trademarks and registered trademarks are the property of their respective owners.

One Technology Way, P.O. Box 9106, Norwood, MA 02062-9106, U.S.A.  
Tel: 781.329.4700 ©2010–2013 Analog Devices, Inc. All rights reserved.  
[Technical Support](#) [www.analog.com](http://www.analog.com)

**NOTES**

I<sup>2</sup>C refers to a communications protocol originally developed by Philips Semiconductors (now NXP Semiconductors).  
HDMI, the HDMI logo, and High-Definition Multimedia Interface are trademarks or registered trademarks of HDMI.