

FEATURES

- **low cost**
- **differential gain at 3.58 MHz, 0.05% max.**
- **differential phase at 3.58 MHz, 0.05 deg. max.**
- **off-isolation better than 90 dB at 10 MHz**
- **all hostile crosstalk at 3.58 MHz, 75 dB typ. ($R_{IN}=75 \Omega$)**
- **make-before-break switching**
- **Pb-free and Green**

FUNCTIONAL BLOCK DIAGRAM

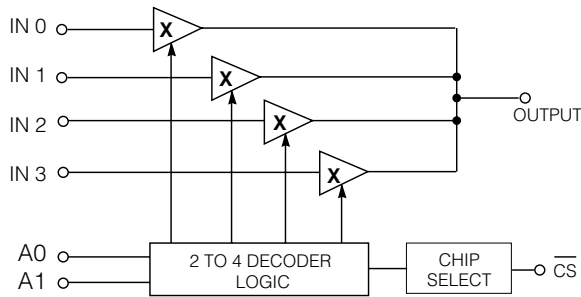

TRUTH TABLE

\overline{CS}	A1	A0	OUTPUT
0	0	0	IN 0
0	0	1	IN 1
0	1	0	IN 2
0	1	1	IN 3
1	X	X	HI - Z

X = DON'T CARE

ORDERING INFORMATION

Part Number	Package Type	Temperature Range	Pb-Free and Green
GX214 - ACDB	14 Pin DIP	0° to 70° C	No
GX214 - ACKC	16 Pin SOIC	0° to 70° C	No
GX214 - ACKB	14 Pin SOIC	0° to 70° C	No
GX214 - ACKBE3	14 Pin SOIC	0° to 70° C	Yes

CIRCUIT DESCRIPTION

The GX214A is a low cost 4x1 video multiplexer containing four analog video switches and a 2 to 4 decoder. A Chip Select input allows paralleled GX214As to be operated in a switching matrix.

The GX214A represents a fully buffered, unilateral transmission path when enabled. When disabled, the output is high impedance.

The device operates from $\pm 7.5 V$ to $\pm 9.5 V$ supplies with TTL and 5 V CMOS compatible input logic levels.

APPLICATIONS

- CATV and CCTV systems
- low cost video routing

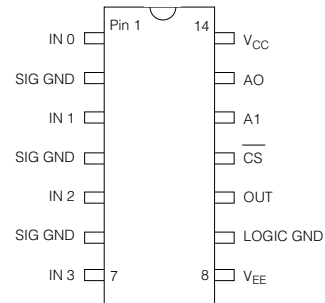

PIN CONNECTION
14 PIN DIP

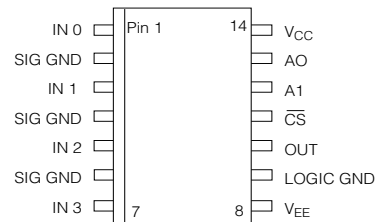

PIN CONNECTION
14 PIN SOIC

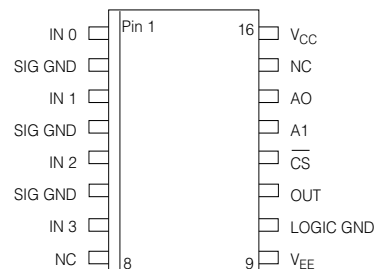

PIN CONNECTION
16 PIN SOIC

ABSOLUTE MAXIMUM RATINGS

Parameter	Value
Supply Voltage	±10.0 V
Operating Temperature Range	0 °C ≤ T _A ≤ 70 °C
Storage Temperature Range	-65 °C ≤ T _S ≤ 150 °C

Parameter	Value
Lead Temperature (Soldering, 10 Sec)	260 °C
Analog Input Voltage	-4 V ≤ V _{IN} ≤ V _{CC} +0.3 V
Logic Input Voltage	0 V ≤ V _L ≤ 5.5 V

NOTE: A short from output to ground or either supply will destroy the device.

For R_{EXT} use a 2.67 k Ω 1%, 1/4 W resistor.

ELECTRICAL CHARACTERISTICS V_S = ±8 V DC, 0°C < T_A < 70 °C, R_L = 2.67 k Ω to V_{EE}, C_L = 30pF I_L = 3mA

	PARAMETER	SYMBOL	CONDITIONS	MIN	TYP	MAX	UNITS
DC SUPPLY	Supply Voltage	±V _S		7.5	8.0	9.5	V
	Supply Current not including I _L	I+	Chip selected ($\overline{CS}=0$)	-	14	20	mA
			Chip not selected ($\overline{CS}=1$)	-	0.5	0.85	mA
		I-	Chip selected ($\overline{CS}=0$)	-	13	18	mA
Chip not selected ($\overline{CS}=1$)			-	0.58	0.88	mA	
STATIC	Analog Output Voltage Swing	V _{OUT}	Extremes before clipping occurs	-	-	+5.0 -1.2	V
	Analog Input Bias Current	I _{IN}		-	25	-	μA
	Output Offset Voltage	V _{OS}	75 Ω resistor on each input to ground	+5	-30	-70	mV
LOGIC	Turn-On Time	t _{ON}	Control input to appearance of signal at output.	-	250	400	ns
	Turn-Off Time	t _{OFF}	Control input to disappearance of signal at output.	500	750	-	ns
	Logic Input Thresholds	V _{IH}	1	2.4	-	-	V
		V _{IL}	0	-	-	0.6	V
	Logic Input Bias Current	I _{BIAS}	Chip Selected A0,A1 = 1	-	-	1	nA
Chip Selected A0,A1 = 0			-	-	2	μA	
DYNAMIC	Insertion Loss	I.L.	1V p-p sine or sq. wave at 100 kHz	0.05	0.08	0.11	dB
	Bandwidth (-3dB)	B.W.		65	85	-	MHz
	Input Resistance	R _{IN}	Chip selected ($\overline{CS} = 0$)	900	-	-	k Ω
	Input Capacitance	C _{IN}	Chip selected ($\overline{CS} = 0$)	-	2.0	-	pF
			Chip not selected ($\overline{CS}=1$)	-	2.2	-	pF
	Output Resistance	R _{OUT}	Chip selected ($\overline{CS}=0$)	-	14	-	Ω
	Output Capacitance	C _{OUT}	Chip not selected ($\overline{CS}=1$)	-	12	-	pF
	Differential Gain	dg	at 3.58 MHz	-	-	0.05	%
	Differential Phase	dp	V _{IN} = 40 IRE	-	-	0.05	deg.
	All Hostile Crosstalk	X _{TALK(AH)}	Sweep on 3 inputs 1V p-p 4th input has 75 Ω resistor to gnd. f = 10 MHz	72	75	-	dB
Chip Disabled Crosstalk	X _{TALK(CD)}	One xpt on output to ground f = 10 MHz	90	100	-	dB	

APPLICATION INFORMATION

The circuit layout of any wideband circuit is critical. Good high frequency design practice, proper lead dress and PCB component placement along with a well regulated and decoupled power supply will assure optimum performance of the crosspoint.

The GX214A is non-inverting. The inputs are buffered and require 75Ω line terminating resistors when driven from 75Ω cable. The inputs may be driven directly from an amplifier which has low output impedance.

The output of the GX214A must be buffered to drive 7Ω lines. The addition of an amplifier/buffer also allows adjustments to be made to the gain, offset and frequency response of the circuit.

Signal Ground (SG) pins 2, 4 and 6 must be joined together and preferably form part of a ground plane. The Signal Ground must also be connected to the $\pm 8V$ power supply ground. The potential of the Logic Ground (LG) pin 9 can deviate from the Signal Ground by $\pm 0.5V$ maximum. Alternatively, the signal and logic grounds can be joined together at one point only.

An external load current of 2 to 8mA should be supplied from each output bus to negative supply. For most applications a load resistor of $2.67k\Omega$, 1% is recommended to minimize offset drift with temperature. In order to improve differential phase and tighten the insertion loss tolerance, an external constant current active load may be substituted for the load resistor. Note however, that since only one GX214A output drives the output bus at any one time, only one external load is needed for the bus.

A typical application is shown below. Two GX214A ICs are paralleled to form an 8×1 crosspoint matrix. The three address lines make use of the A0, A1 and CS inputs. If more than two devices are used in parallel, a decoder is necessary in order to generate the extra address inputs.

Depending on the application and the speed of the logic family used, latches may be required for synchronization where timing delays are critical. The active switching circuitry of the GX214A ensures low crosstalk and high performance over an input voltage range of -1.2 to $+5.0$ volts.

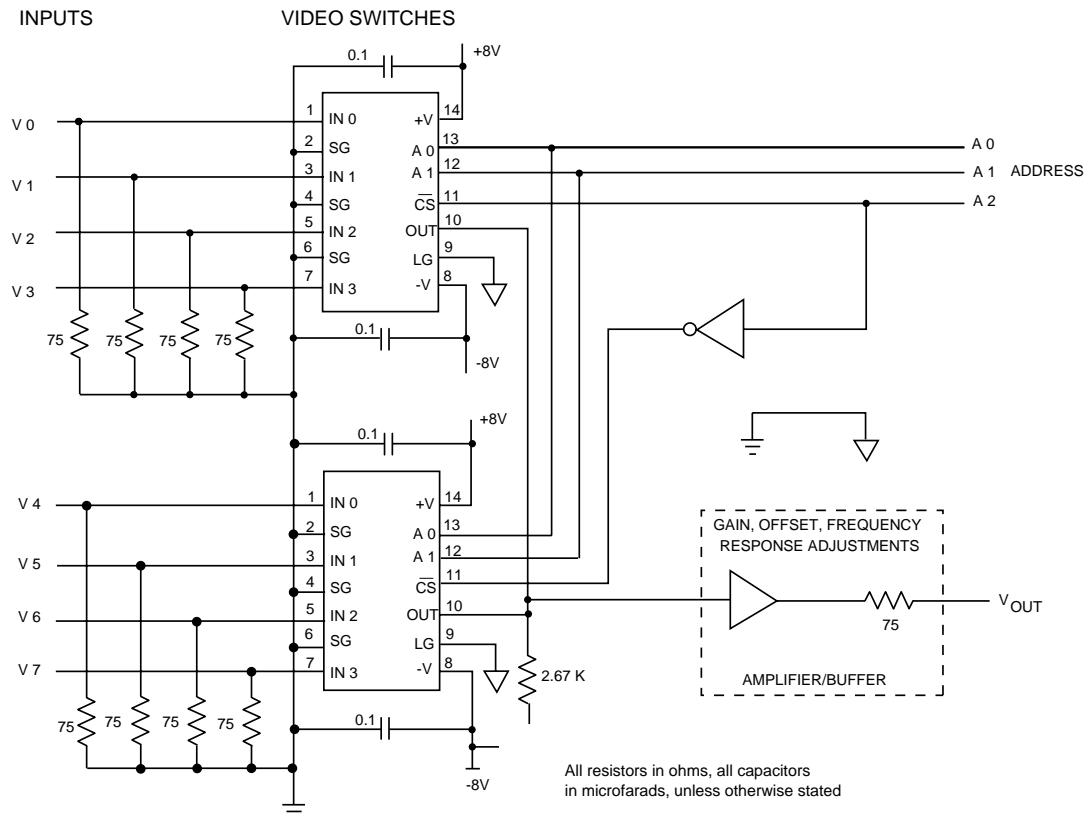

Fig. 1 8×1 Video Multiplexer Incorporating Two GX214A Devices

TYPICAL PERFORMANCE CURVES FOR GX214A

$V_S = \pm 8V$, $C_L = 30pF$, $I_L = 3mA$ unless otherwise shown

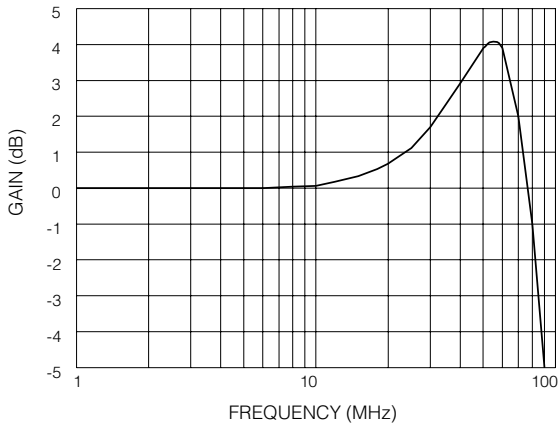

Fig. 2 Gain vs Frequency

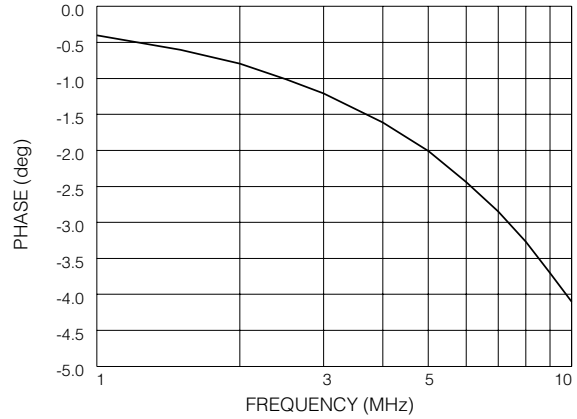

Fig. 3 Phase vs Frequency

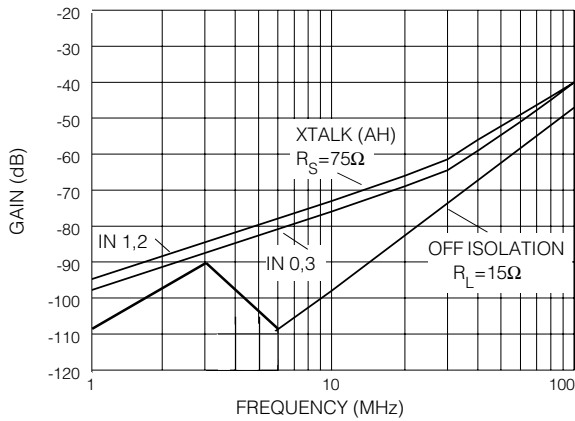

Fig. 4 All - Hostile Crosstalk & Off-Isolation vs Frequency

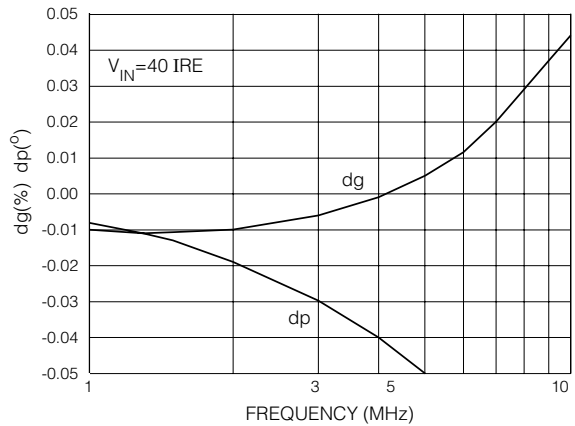
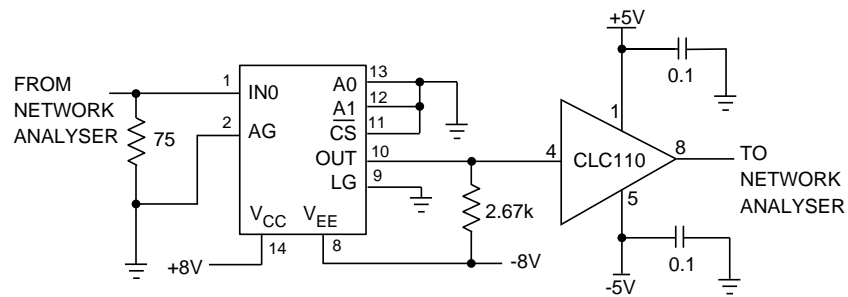

Fig. 5 Differential Gain & Phase vs Frequency



* The power supply pins should be suitably decoupled with at least 0.1μF, high quality capacitors
All resistors in ohms, all capacitors in microfarads unless otherwise stated.

Fig. 6 Test Circuit

The TEST SET UP shown is for INPUT 0 tests. Similar circuitry is used for each input INPUT in order to test FREQUENCY RESPONSE and PHASE DELAY. For OFF-ISOLATION, all switches are disabled (CHIP SELECT = logic 1) and a second enabled GX214A is connected to the output bus. For ALL-HOSTILE CROSSTALK, three OFF switches are driven from the generator and the fourth is terminated with a 75Ω resistor. For the DIFFERENTIAL GAIN and PHASE tests, the output is AC coupled to the output amplifier and the input level from the generator is modulated with a step signal varying between 0 volts DC and 0.714 volts DC.

REVISION NOTES

Added lead-free and green information.

CAUTION
ELECTROSTATIC
SENSITIVE DEVICES
DO NOT OPEN PACKAGES OR HANDLE
EXCEPT AT A STATIC-FREE WORKSTATION



**DOCUMENT
IDENTIFICATION**

PRODUCT PROPOSAL

This data has been compiled for market investigation purposes only, and does not constitute an offer for sale.

ADVANCE INFORMATION NOTE

This product is in development phase and specifications are subject to change without notice. Gennum reserves the right to remove the product at any time. Listing the product does not constitute an offer for sale.

PRELIMINARY DATA SHEET

The product is in a preproduction phase and specifications are subject to change without notice.

DATA SHEET

The product is in production. Gennum reserves the right to make changes at any time to improve reliability, function or design, in order to provide the best product possible.