

MX150 WIRE SEAL BLADE CRIMP TERMINAL

1.0 SCOPE

This specification details the crimping information and common practices of general crimps for the Molex MX150 Wire Seal Blade Terminal. Please refer to sales drawing SD-34080-001 for additional part information. The information in this document is for reference and benchmark purposes only. Customers are required to complete their own validation testing if tooling and/or wire is different than what is shown in this specification.

All measurements are in millimeters and Newtons unless otherwise specified.

Terminals shown in this document are generic representations. They are not intended to be an image of any terminal listed in the scope.

2.0 PRODUCT DESCRIPTION

DEFINITION OF TERMS:

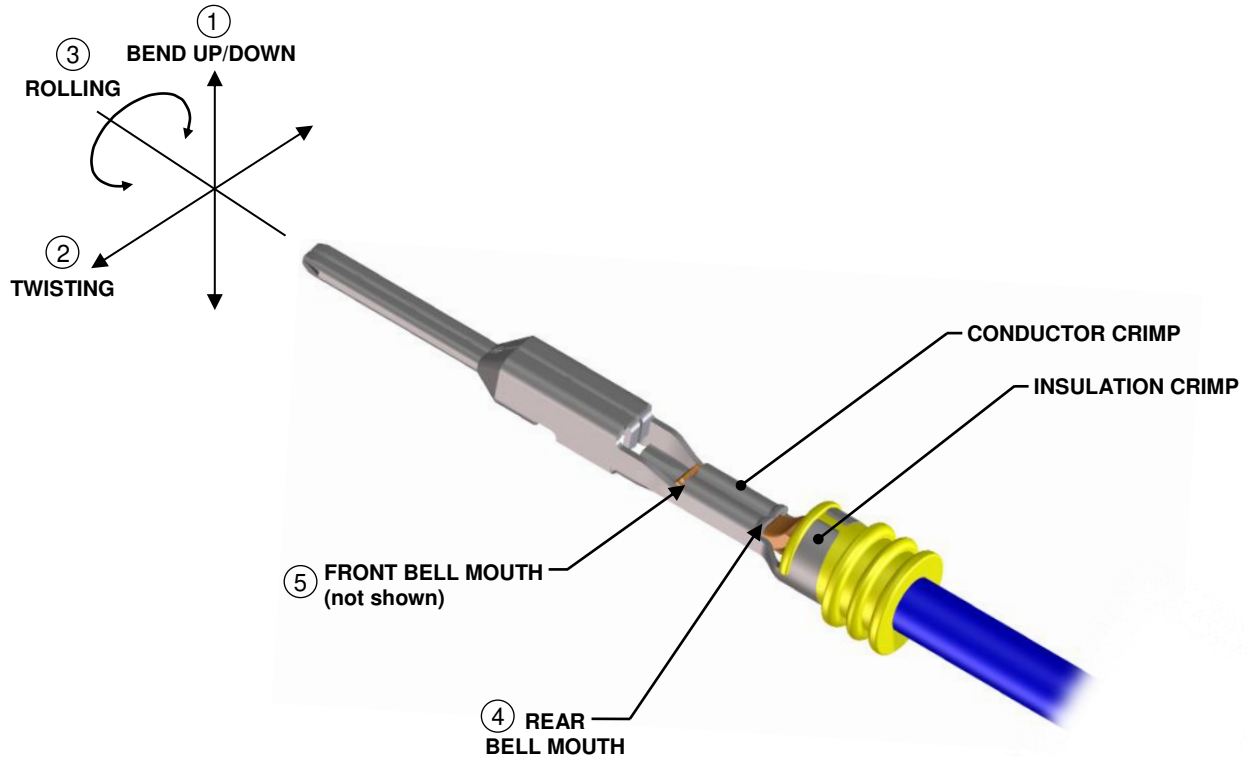

Figure 1

REVISION: B1	ECR/ECN INFORMATION: EC No: UAU2015-0357 DATE: 2014 / 08 / 25	MX150 WIRE SEAL BLADE APPLICATION SPECIFICATION		SHEET No. 1 of 18
DOCUMENT NUMBER: AS-34080-001	CREATED / REVISED BY: B.Jennings	CHECKED BY: A.Dhir	APPROVED BY: B.Moser	

DEFINITIONS OF TERMS (CONT.):

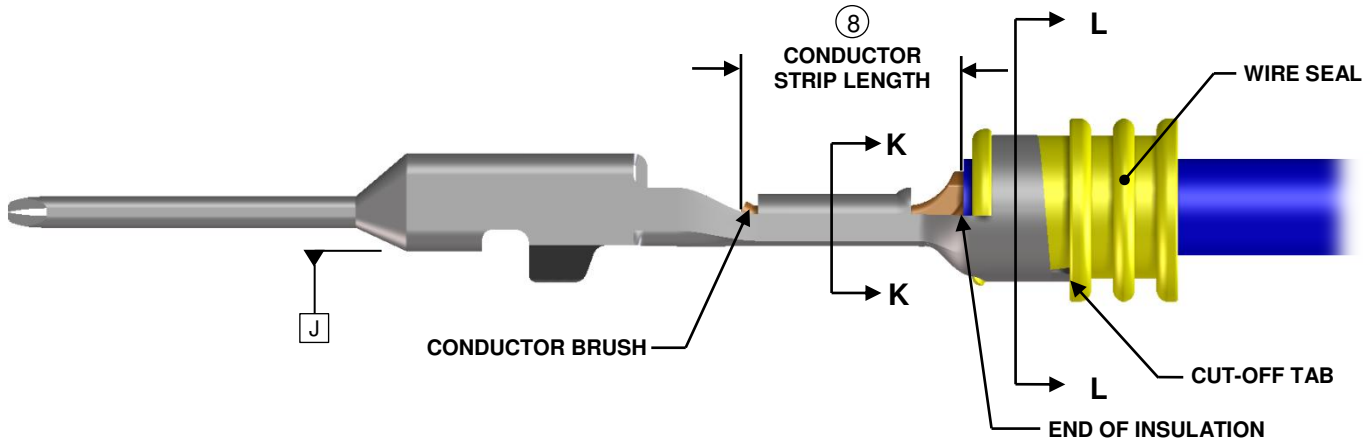

Figure 2

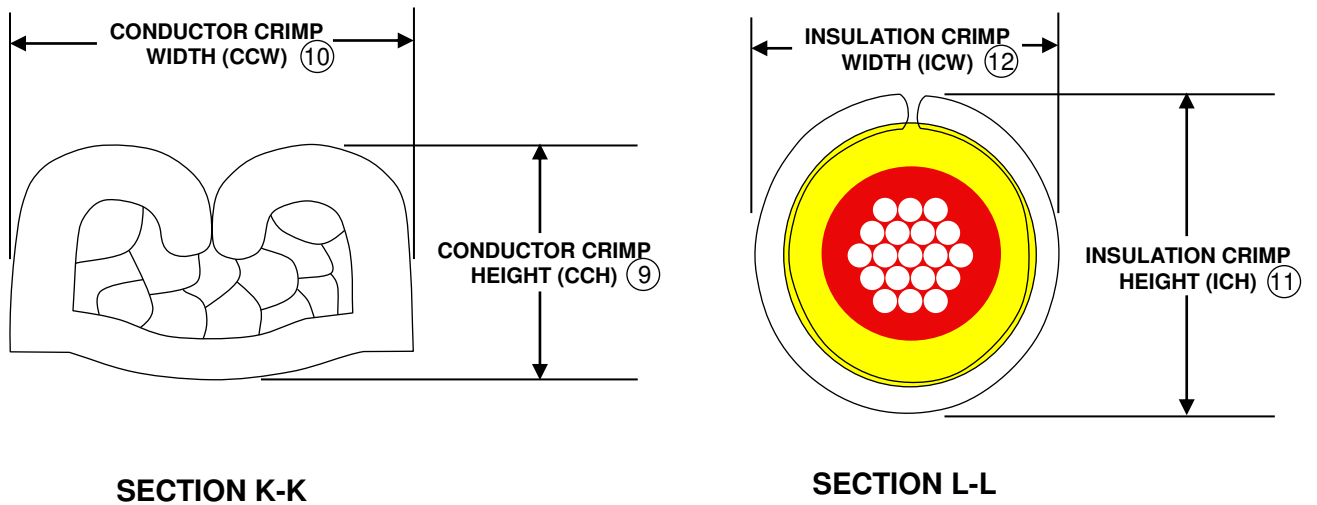

Figure 3

REVISION: B1	ECR/ECN INFORMATION: EC No: UAU2015-0357 DATE: 2014 / 08 / 25	MX150 WIRE SEAL BLADE APPLICATION SPECIFICATION		SHEET No. 2 of 18
DOCUMENT NUMBER: AS-34080-001		CREATED / REVISED BY: B.Jennings	CHECKED BY: A.Dhir	APPROVED BY: B.Moser

STRAIGHTNESS MEASUREMENTS

The crimping process may result in some bending between the conductor crimp and the terminal box. This bending must not exceed the limits shown in Table 4.

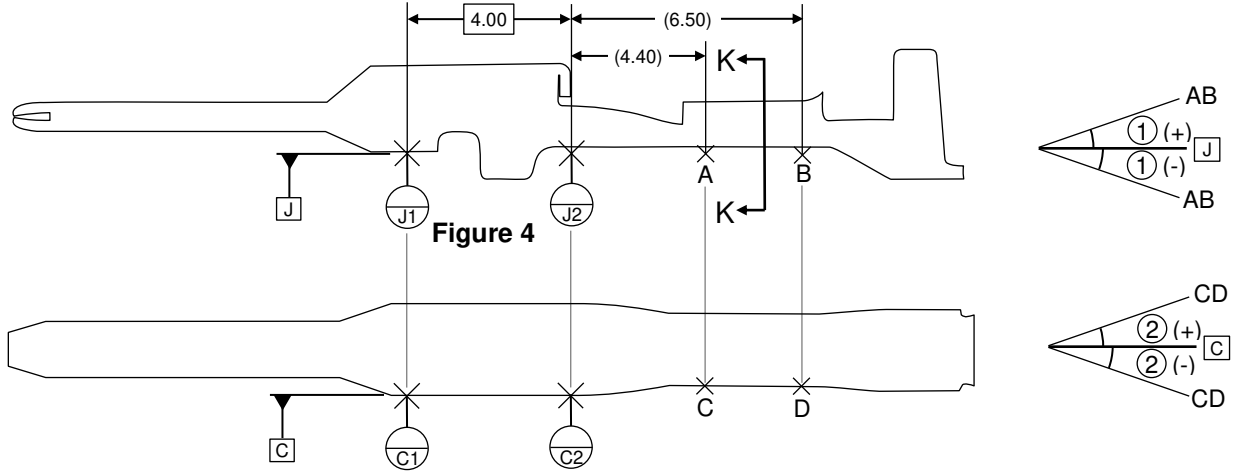

Figure 5

BEND UP/DOWN ①

To measure bend up/down, establish datum J as shown in Figure 4 then measure the angle of the line defined by points A and B with respect to the datum. Positive angles are defined as bend up and negative angles are defined as bend down.

TWISTING ②

To measure twisting, establish datum C as shown in Figure 5, then measure the angle of the line defined by points C and D with respect to the datum.

ROLLING ③

To measure rolling, cross section the part at section K-K (see Figure 4), then clamp the part in a vice as shown in Figure 6. Using a shadowgraph, focus the graph to section H-H and establish line M-M as the top of the terminal box. With line M-M established, refocus the graph to section J-J. Measure the angle of the line defined by points E and F with respect to line M-M.

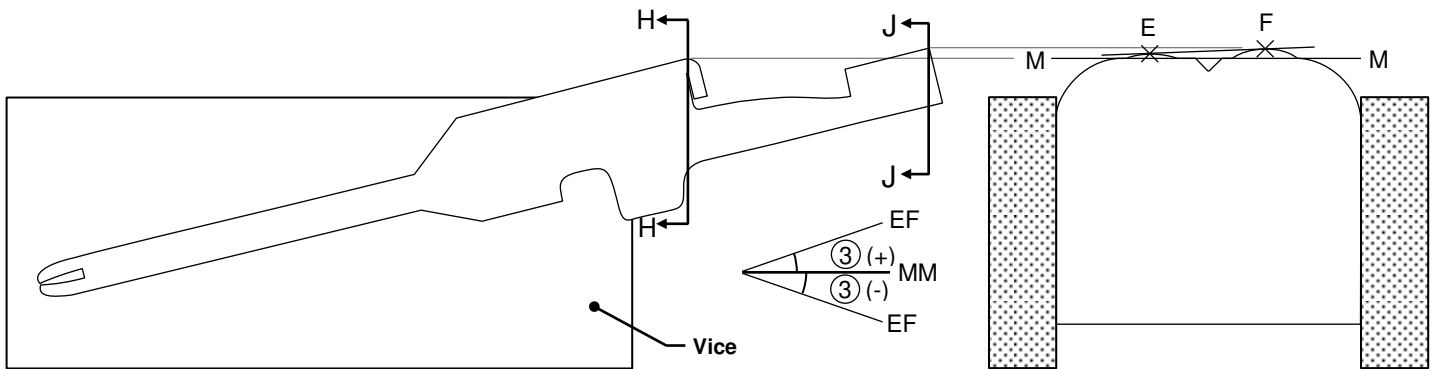

Figure 6

REVISION: B1	ECR/ECN INFORMATION: EC No: UAU2015-0357 DATE: 2014 / 08 / 25	MX150 WIRE SEAL BLADE APPLICATION SPECIFICATION		SHEET No. 3 of 18
DOCUMENT NUMBER: AS-34080-001	CREATED / REVISED BY: B.Jennings	CHECKED BY: A.Dhir	APPROVED BY: B.Moser	

BELLMOUTH (FLARE) ④⑤

The flare that is formed on the edge of the conductor crimp acts as a funnel for the wire strands. This funnel reduces the possibility that a sharp edge on the conductor crimp will cut or nick the wire strands. A rear bellmouth is required on the conductor crimp. A front bellmouth is optional. Caution: Excessively large bellmouths will reduce crimp area and reduce pull forces. See Table 4 for bellmouth specifications.

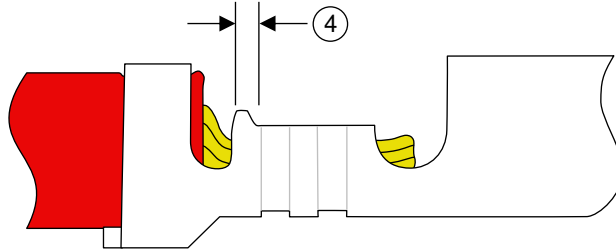

Figure 7

CUT- OFF TAB ⑥

This is the material that protrudes outside the insulation crimp after the terminal is separated from the carrier strip. A cut-off tab that is too long may expose a terminal outside the housing and it may fail electrical spacing requirements. In most situations, a tool is setup to provide a cut-off tab that shall not exceed the value indicated in Table 4. CAUTION: Burrs on the cut-off tab are not allowed as they have the potential to cut mat seals.

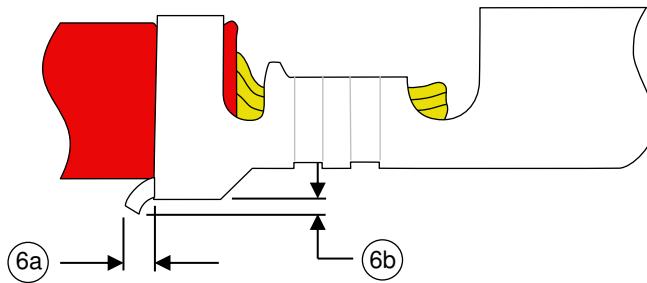

Figure 8

CONDUCTOR BRUSH ⑦

The conductor brush is made up of the wire strands that extend past the conductor crimp on the contact side of the terminal. This helps ensure that mechanical compression occurs over the full length of the conductor crimp. The conductor brush should not extend into the contact area or above the conductor crimp/transition wall height (whichever is tallest), see Figure 9 and Table 4. CAUTION: Excessive conductor brush extended above the transition/crimp area can cause terminal retention issues inside plastic cavity and potentially could compromise/tear the glands of the mat seal.

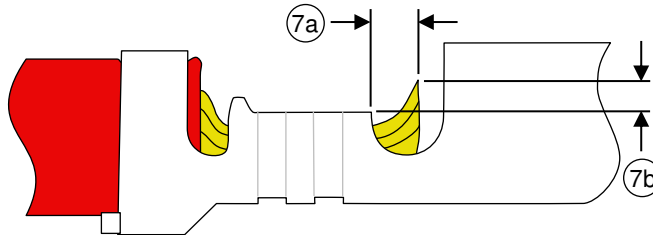

Figure 9

REVISION: B1	ECR/ECN INFORMATION: EC No: UAU2015-0357 DATE: 2014 / 08 / 25	MX150 WIRE SEAL BLADE APPLICATION SPECIFICATION		SHEET No. 4 of 18
DOCUMENT NUMBER: AS-34080-001	CREATED / REVISED BY: B.Jennings	CHECKED BY: A.Dhir	APPROVED BY: B.Moser	

CONDUCTOR STRIP LENGTH ⑧

The strip length is determined by measuring the exposed conductor strands after the insulation is removed. The strip length determines the conductor brush length when the end-of-insulation position is centered in the transition area between conductor and insulation crimps. See Table 4 for the length requirement.

CAUTION: Care must be taken to ensure that all conductor strands are equal in length (no diagonally cut strands). No scratched or missing strands are permitted. The insulation cut must be uniform (no diagonally cut insulation and no extrusions of insulation).

CONDUCTOR CRIMP

This is the metallurgical compression of a terminal around the wire's conductor. This connection creates a common electrical path with low resistance and high current carrying capabilities. The crimp seam shall not be open and all conductor strands must be contained within the conductor crimp.

CONDUCTOR CRIMP HEIGHT ⑨

The conductor crimp height is measured from the top surface of the formed crimp to the bottom most radial surface. Do not include the extrusion points in this measurement. Measuring crimp height is a quick, non-destructive way to help ensure the correct metallurgical compression of a terminal around the wire's conductor and is an excellent attribute for process control. The crimp height specification is typically set as a balance between electrical and mechanical performance over the complete range of wire stranding and coatings, and terminal materials and plating. Although it is possible to optimize a crimp height to individual wire strands and terminal plating, one crimp height specification is normally created. See Table 3 for crimp height specifications.

INSULATION CRIMP HEIGHT ⑪

Insulation crimp heights are specified in Table 3. MX150 Wire Seal Blade Terminals are designed to accommodate multiple wire sizes. Although within the terminal range, an insulation grip may not completely surround the wire, an acceptable insulation crimp will still be provided.

The insulation crimp should be visually evaluated to confirm it provides adequate compression on the wire. It should also be evaluated by sectioning through the center of the crimped insulation grip. The grip should compress the insulation but not pierce it or otherwise damage the integrity of the insulation. The grip should not contact the conductors under any circumstance.

Once the optimum setting for an insulation crimp height is determined, it is important to document it. The operator can then check it as part of the setup procedure.

CONDUCTOR ANVIL FLASH (EXTRUSION / BURR) ⑬

These are the small flares that form on the bottom of the conductor crimp resulting from the clearance between the punch and anvil tooling. If the anvil is worn or the terminal is over-crimped, excessive extrusion can result.

An uneven extrusion may also result if the punch and anvil are misaligned, if the feed is misadjusted or if there is insufficient or excessive terminal drag (see Figure 10 and Table 4).

Note: Anvil Flash (Burr) may not extend below the bottom of the crimp.

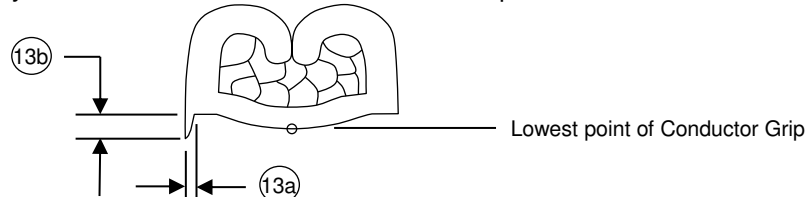

Figure 10

REVISION: B1	ECR/ECN INFORMATION: EC No: UAU2015-0357 DATE: 2014 / 08 / 25	MX150 WIRE SEAL BLADE APPLICATION SPECIFICATION		SHEET No. 5 of 18
DOCUMENT NUMBER: AS-34080-001	CREATED / REVISED BY: B.Jennings	CHECKED BY: A.Dhir	APPROVED BY: B.Moser	

INSULATION GRIP STEP ^⑬

The insulation grip step is the designed offset between the conductor grip and the insulation grip. This dimension must be achieved after the crimp is performed (see Figure 11 and Table 4).

WIRE SEAL POSITION

^⑭ The wire seal is positioned on the wire such that the wire insulation is visible between the conductor and seal by a minimum value specified in Table 4. This minimum requirement ensures that the seal is in no risk of being damaged, torn or crimped within the conductor grip area (see Figure 11).

^⑮ The wire seal is also positioned within the terminal insulation grip such that the wings are only crimped around the shaft of seal. The value specified in Table 4 ensures that the seal lips/glands are in no harm of being crimped within the insulation grip. The value is to be held during crimping, but will not be the final dimension due to the deformation of the wire seal involved in the crimping process (see Figure 11).

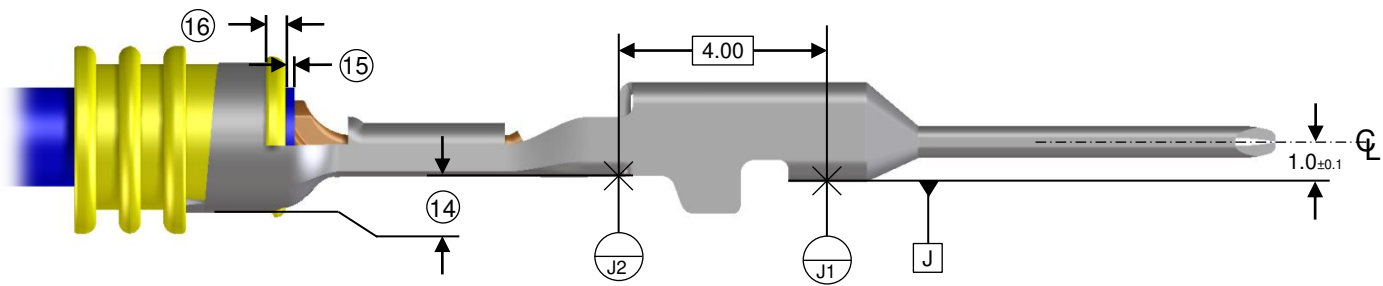

Figure 11

END-OF-INSULATION POSITION

This is the location of the insulation in relation to the transition area between the conductor and insulation crimps. Equal amounts of the conductor strands and insulation needs to be visible in the transition area. The insulation position ensures that the insulation is crimped along the full length of the insulation crimp, and that no insulation gets crimped under the conductor crimp. The insulation position is set by the wire stop and strip length for bench applications. For automatic wire processing applications the insulation position is set by the in/out press adjustment (see Figure 2).

REVISION: B1	ECR/ECN INFORMATION: EC No: UAU2015-0357 DATE: 2014 / 08 / 25	MX150 WIRE SEAL BLADE APPLICATION SPECIFICATION		SHEET No. 6 of 18
DOCUMENT NUMBER: AS-34080-001		CREATED / REVISED BY: B.Jennings	CHECKED BY: A.Dhir	APPROVED BY: B.Moser

CRIMP BULGE ⑰

Caution needs to be taken with the crimp tooling to prevent a bulge in the transition area during crimping. The transition should generally flow smoothly from the conductor crimp to the terminal box. Any bulge must not exceed the width shown in Table 4. See Figure 12 for an example of crimp bulge.

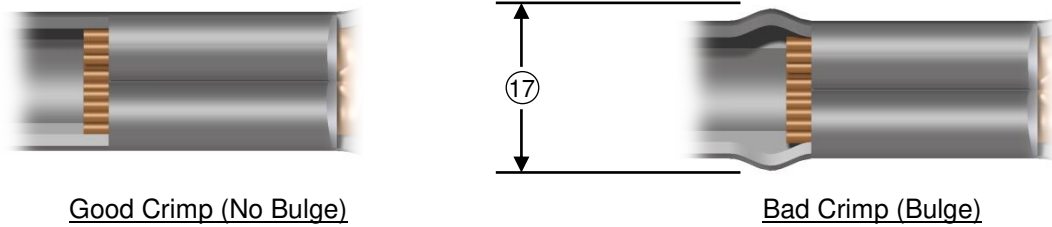

Figure 12

DEFORMATION

Care must be taken to ensure that the terminal box and blade section are not deformed during crimping and handling. Any deformation of the blade position relative to the terminal box must not exceed the tolerances specified in sales drawing SD-34080-001.

<p>REVISION: B1</p>	<p>ECR/ECN INFORMATION: EC No: UAU2015-0357 DATE: 2014 / 08 / 25</p>	<p>MX150 WIRE SEAL BLADE APPLICATION SPECIFICATION</p>		<p>SHEET No. 7 of 18</p>
<p>DOCUMENT NUMBER: AS-34080-001</p>		<p>CREATED / REVISED BY: B.Jennings</p>	<p>CHECKED BY: A.Dhir</p>	<p>APPROVED BY: B.Moser</p>

3.0 PRODUCT SPECIFICATIONS

Table 1

Terminal Family	Gender	Sealing	Plating	Special Characteristics	Grip Size	Wire Size	Insulation Diameter Range (mm)
MX150	Blade	Wire Seal	Sn	High Performance Tin	22	22AWG 0.35 – 0.50mm ²	1.20 – 1.70
			Au	High Performance Gold			
			Ag	High Performance Silver			
			Sn	High Performance Tin	18	20 – 18AWG 0.75 – 1.00mm ²	1.60 – 2.54
			Au	High Performance Gold			
			Ag	High Performance Silver			
			Sn	High Performance Tin	14	16 – 14AWG 1.50 – 2.00mm ²	2.10 – 2.70
			Au	High Performance Gold			
			Ag	High Performance Silver			

Table 2

Wire Seal	Pink	Green	Yellow	Gray
				
Acceptable Wire Diameter	1.20 – 1.70	1.60 – 2.10	2.10 – 2.54	2.54 – 2.70
QSR Part No.	E-1644-01	E-1644-00	E-1644-02	
Yazaki Part No.				7158-3033-40
Ford Part No.	97BG-10C930-SBA	XW43-14603-AA	XW4T-14603-FA	XW4T-14603-MA22

REVISION: B1	ECR/ECN INFORMATION: EC No: UAU2015-0357 DATE: 2014 / 08 / 25	MX150 WIRE SEAL BLADE APPLICATION SPECIFICATION		SHEET No. 8 of 18
DOCUMENT NUMBER: AS-34080-001		CREATED / REVISED BY: B.Jennings	CHECKED BY: A.Dhir	APPROVED BY: B.Moser



APPLICATION SPECIFICATION

Table 3

Grip Code	Special Characteristics	Validated Wire		Conductor Barrel		Insulation Barrel		Wire Seal	Pull Out Force (N) MIN
		Wire Type	Wire Size	CCH ± 0.05	CCW ± 0.10	ICH ± 0.10	ICW ± 0.10		
22	High Performance Tin High Performance Gold High Performance Silver	M1L-123A4 (TXL)	22AWG	1.00	1.60	3.50	3.45	Pink	50
		GMW15626 (FLR2XA3ZH)	0.35mm ²	1.04 ± 0.03					50
		M1L-126A1	0.50mm ²	1.10					75
		JASO D611 (AVSS)	0.50mm ²	1.10					75
18	High Performance Tin High Performance Gold High Performance Silver	M1L-123A4 (TXL)	20AWG	1.15	2.15	3.60	3.55	Green	75
		SAE J1128 (GXL)	20AWG	1.15		3.80		Yellow	75
		M1L-123A4 (TXL)	18AWG	1.25		3.70		Green	90
		SAE J1128 (GXL)	18AWG	1.25		3.90		Yellow	90
		M1L-126A1	0.75mm ²	1.25		3.60		Green	90
		M1L-126A1	1.00mm ²	1.30		3.70		Green	120
14	High Performance Tin High Performance Gold High Performance Silver	M1L-123A4 (TXL)	16AWG	1.35	2.45	3.80	3.65	Yellow	120
		M1L-135A1 (UTX)	14AWG	1.65		3.80			180
		M1L-123A4 (TXL)	14AWG	1.65		3.95		Gray	180
		M1L-126A1	1.50mm ²	1.40		3.80		Yellow	150
		JASO D611 (AVSS)	2.00mm ²	1.60		3.95		Gray	180

The above specifications are guidelines to an optimum crimp. Crimp heights/widths are applicable for punch/anvil tooling shown in Figures 15 – 19

Pull force should be measured with no influence from the insulation crimp

Customers are required to complete their own validation testing if tooling and/or wire is different than what is shown in this specification.

Terminals were validated per USCAR-21

REVISION: B1	ECR/ECN INFORMATION: EC No: UAU2015-0357 DATE: 2014 / 08 / 25	MX150 WIRE SEAL BLADE APPLICATION SPECIFICATION			SHEET No. 9 of 18
DOCUMENT NUMBER: AS-34080-001		CREATED / REVISED BY: B.Jennings	CHECKED BY: A.Dhir	APPROVED BY: B.Moser	

Table 4

Specifications		
Balloon #	Feature	Requirement
1	Bend Up/Down	± 3° MAX
2	Twisting	± 3° MAX
3	Rolling	± 3° MAX
4	Rear Bell Mouth	0.30 – 0.70
5	Front Bell Mouth	Not Required
6	Cut-Off Tab	0.50 MAX
7	Conductor Brush	a 0.40 MAX
		b MAX 0.40 above conductor crimp
8	Conductor Strip Length	4.70 – 5.60
9	Conductor Crimp Height	See Table 3
10	Conductor Crimp Width	See Table 3
11	Insulation Crimp Height	See Table 3
12	Insulation Crimp Width	See Table 3
13	Conductor Anvil Flash	a 0.1 MAX
		b Not to extend below lowest point of conductor crimp
14	Grip Step From J1-J2 (see Figure 11)	Grip Code 22 0.55 ± 0.10
		Grip Code 18 0.70 ± 0.10
		Grip Code 14 0.90 ± 0.10
15	Wire Seal Position on Wire	0.2 – 0.4 for reference
16	Wire Seal Position on Terminal	1.10 MIN
17	Crimp Bulge	2.65 MAX

REVISION:

B1

ECR/ECN INFORMATION:

EC No: **UAU2015-0357**

DATE: **2014 / 08 / 25**

**MX150 WIRE SEAL BLADE
APPLICATION SPECIFICATION**

SHEET No.

10 of 18

DOCUMENT NUMBER:

AS-34080-001

CREATED / REVISED BY:

B.Jennings

CHECKED BY:

A.Dhir

APPROVED BY:

B.Moser

4.0 REFERENCE DOCUMENTS

Reference documentation for general practices is located on the website per the below links:

1. Molex Quality Crimping Handbook http://www.molex.com/images/products/apptool/qual_crimp.pdf
2. Molex-Recognizing Good Crimps <http://www.molex.com>, search for Application Tooling

5.0 PROCEDURE

5.1 GENERAL MEASUREMENT AND EVALUATION REQUIREMENTS

Crimp Height Measurement (Anvil Flash Evaluation)

1. Complete tool set-up procedure.
2. Crimp a minimum of 5 samples.
3. Place the flat blade of the crimp micrometer across the center of the dual radii of the conductor crimp. Do not take the measurement near the conductor bell mouth (see Figure 13).
4. Rotate the micrometer dial until the point contacts the bottom most radial surface. If using a caliper, be certain not to measure the conductor anvil flash (extrusions) of the crimp (see Figure 14).

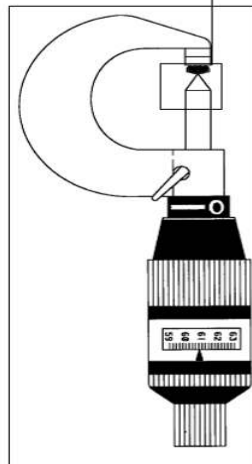
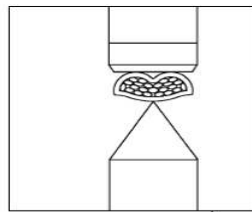

Figure 13

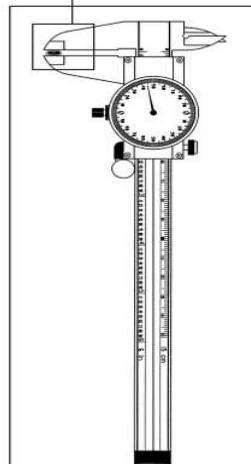
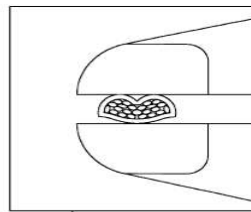
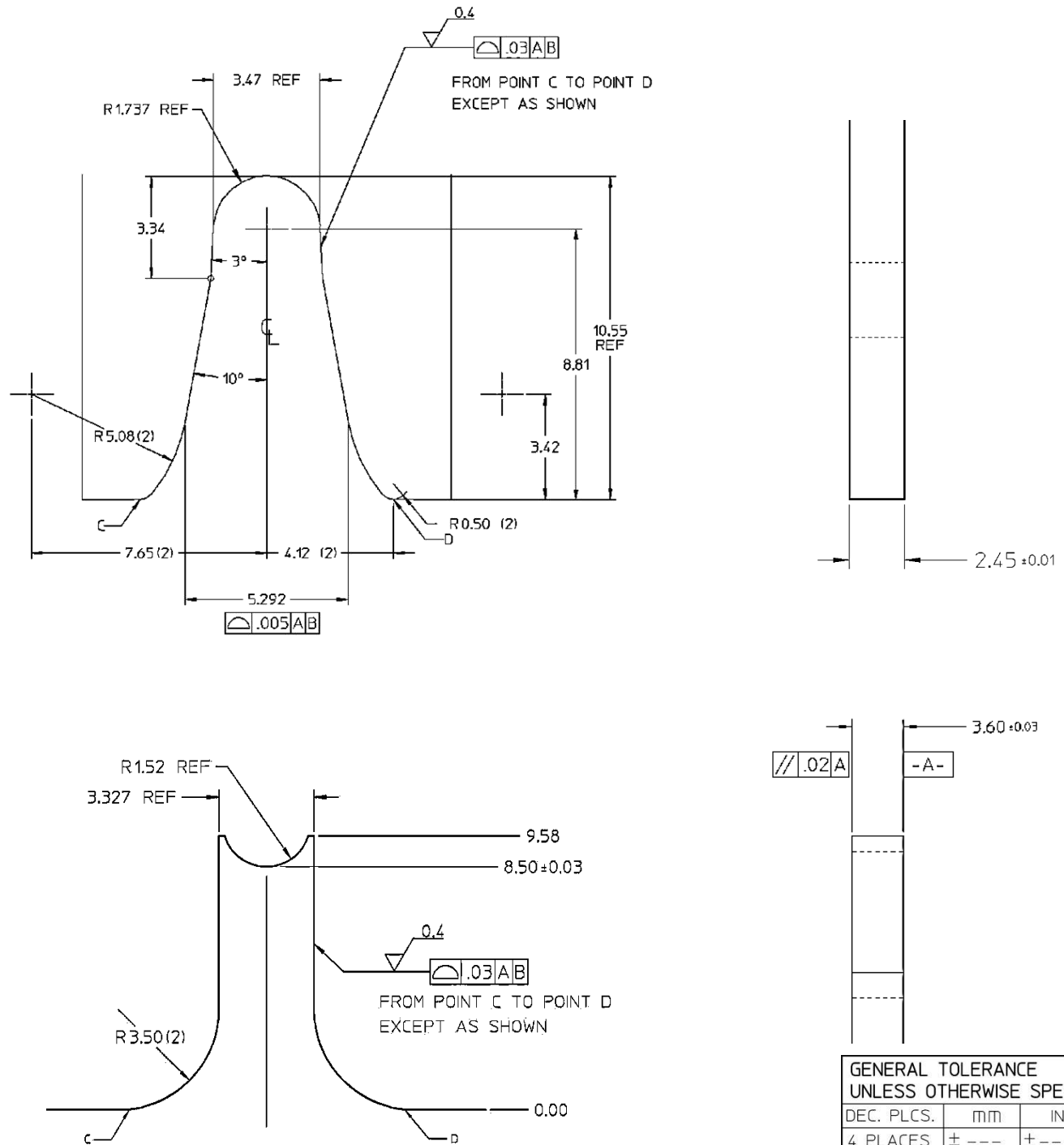

Figure 14

6.0 CRIMP TOOLING GEOMETRY

The crimp tooling information shown below defines the tooling used by Molex to perform validation testing to establish recommended crimp height and widths. The user is responsible for validating crimp performance based on tooling, equipment and wire that is being used.

REVISION: B1	ECR/ECN INFORMATION: EC No: UAU2015-0357 DATE: 2014 / 08 / 25	MX150 WIRE SEAL BLADE APPLICATION SPECIFICATION		SHEET No. 11 of 18
DOCUMENT NUMBER: AS-34080-001	CREATED / REVISED BY: B.Jennings	CHECKED BY: A.Dhir	APPROVED BY: B.Moser	



**Figure 15 – Insulation Tooling Geometry
(Grip Code 22 ONLY)**

GENERAL TOLERANCE UNLESS OTHERWISE SPECIFIED		
DEC. PLCS.	mm	INCH
4 PLACES	± ---	± ---
3 PLACES	± ---	± ---
2 PLACES	± 0.13	± ---
1 PLACE	± 0.25	± ---
ANGULAR	± 0.5°	

REVISION: B1	ECR/ECN INFORMATION: EC No: UAU2015-0357 DATE: 2014 / 08 / 25	MX150 WIRE SEAL BLADE APPLICATION SPECIFICATION		SHEET No. 12 of 18
DOCUMENT NUMBER: AS-34080-001	CREATED / REVISED BY: B.Jennings	CHECKED BY: A.Dhir	APPROVED BY: B.Moser	

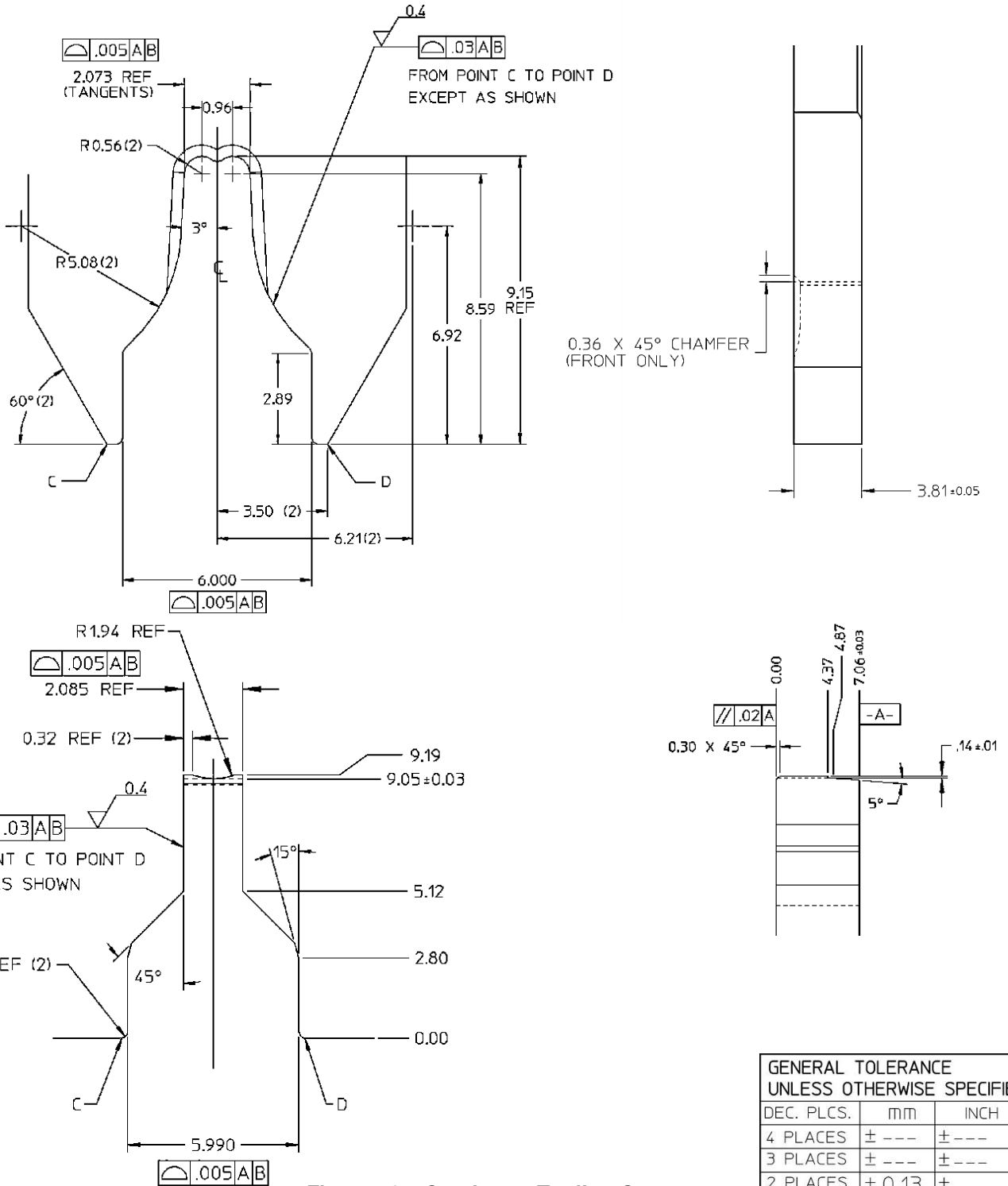

Figure 16 – Conductor Tooling Geometry (Grip Code 18 ONLY)

GENERAL TOLERANCE UNLESS OTHERWISE SPECIFIED		
DEC. PLCS.	mm	INCH
4 PLACES	± ---	± ---
3 PLACES	± ---	± ---
2 PLACES	± 0.13	± ---
1 PLACE	± 0.25	± ---
ANGULAR	± 0.5°	

REVISION: B1	ECR/ECN INFORMATION: EC No: UAU2015-0357 DATE: 2014 / 08 / 25	MX150 WIRE SEAL BLADE APPLICATION SPECIFICATION		SHEET No. 13 of 18
DOCUMENT NUMBER: AS-34080-001	CREATED / REVISED BY: B.Jennings	CHECKED BY: A.Dhir	APPROVED BY: B.Moser	

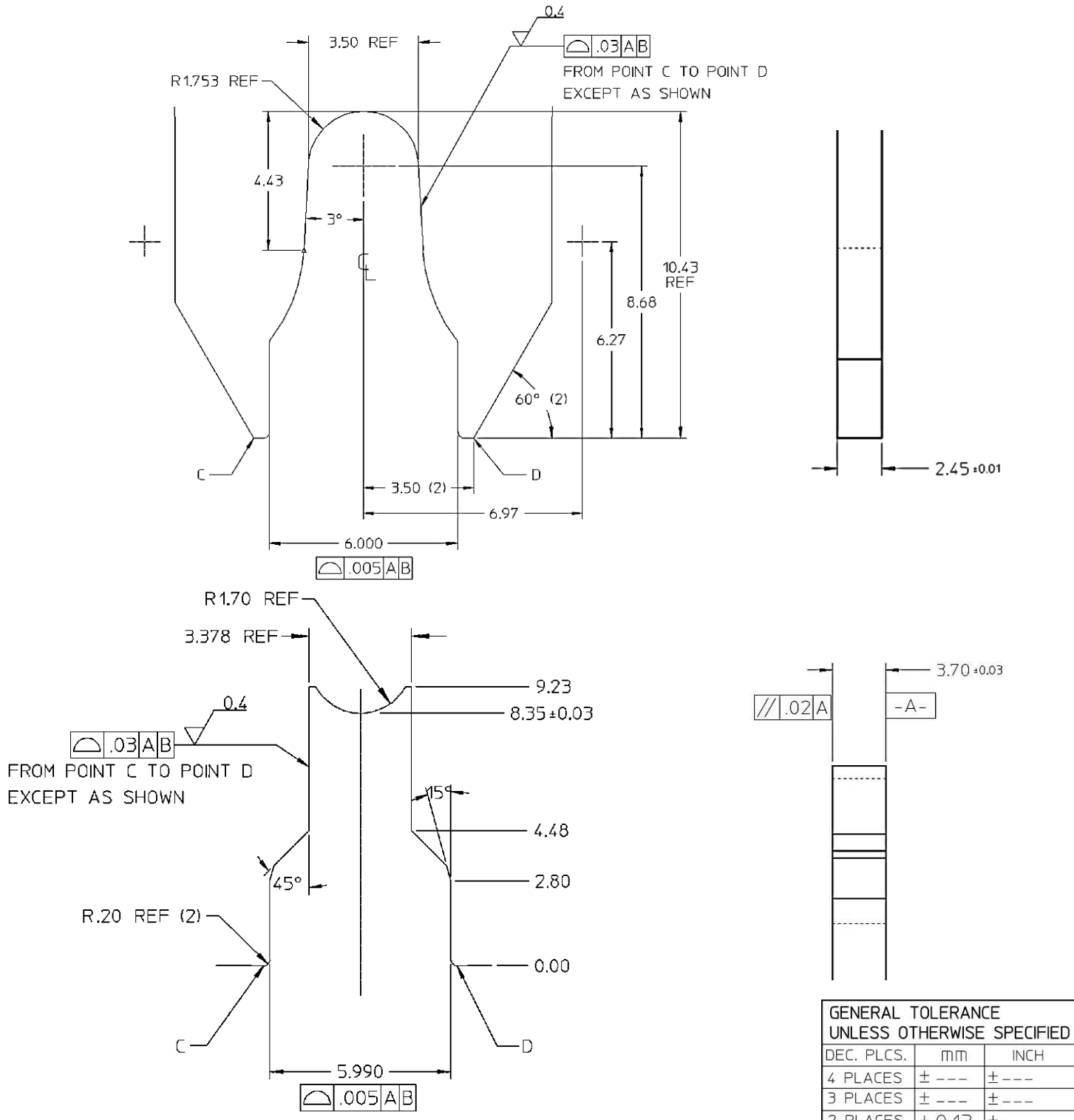

Figure 17 – Insulation Tooling Geometry (Grip Code 18 ONLY)

GENERAL TOLERANCE UNLESS OTHERWISE SPECIFIED		
DEC. PLCS.	mm	INCH
4 PLACES	± ---	± ---
3 PLACES	± ---	± ---
2 PLACES	± 0.13	± ---
1 PLACE	± 0.25	± ---
ANGULAR	± 0.5°	

REVISION: B1	ECR/ECN INFORMATION: EC No: UAU2015-0357 DATE: 2014 / 08 / 25	MX150 WIRE SEAL BLADE APPLICATION SPECIFICATION		SHEET No. 14 of 18
DOCUMENT NUMBER: AS-34080-001	CREATED / REVISED BY: B.Jennings	CHECKED BY: A.Dhir	APPROVED BY: B.Moser	

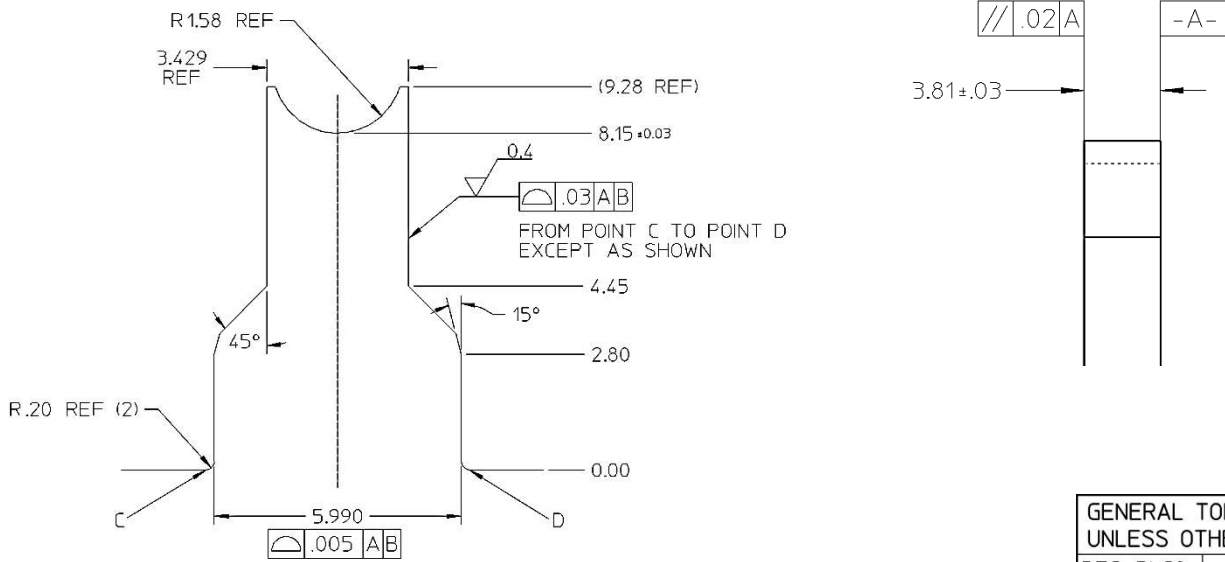
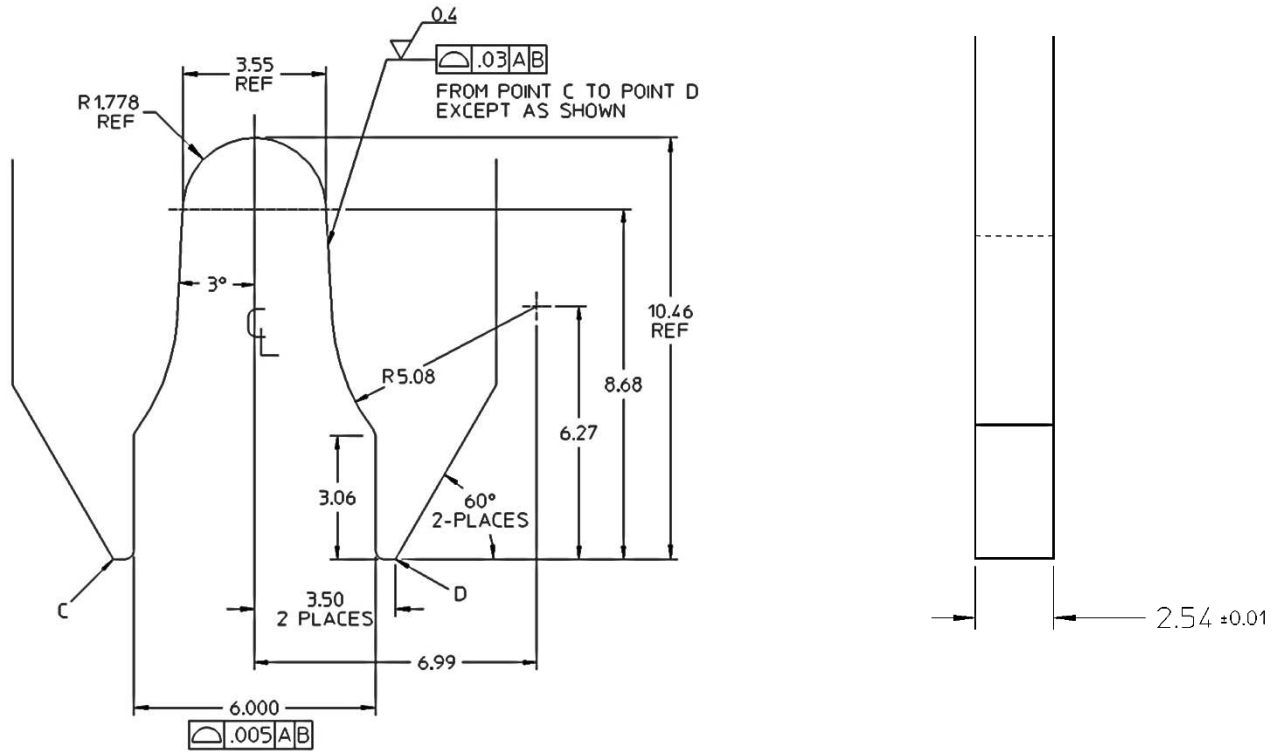

Figure 19 – Insulation Tooling Geometry (Grip Code 14 ONLY)

GENERAL TOLERANCE UNLESS OTHERWISE SPECIFIED		
DEC. PLCS.	mm	INCH
4 PLACES	± ---	± ---
3 PLACES	± ---	± ---
2 PLACES	± 0.13	± ---
1 PLACE	± 0.25	± ---
ANGULAR	± 0.5°	

REVISION: B1	ECR/ECN INFORMATION: EC No: UAU2015-0357 DATE: 2014 / 08 / 25	MX150 WIRE SEAL BLADE APPLICATION SPECIFICATION		SHEET No. 16 of 18
DOCUMENT NUMBER: AS-34080-001	CREATED / REVISED BY: B.Jennings	CHECKED BY: A.Dhir	APPROVED BY: B.Moser	

7.0 CRIMP STRAIGHTNESS

A sample method for maintaining crimp straightness is shown in Figure 20 below.

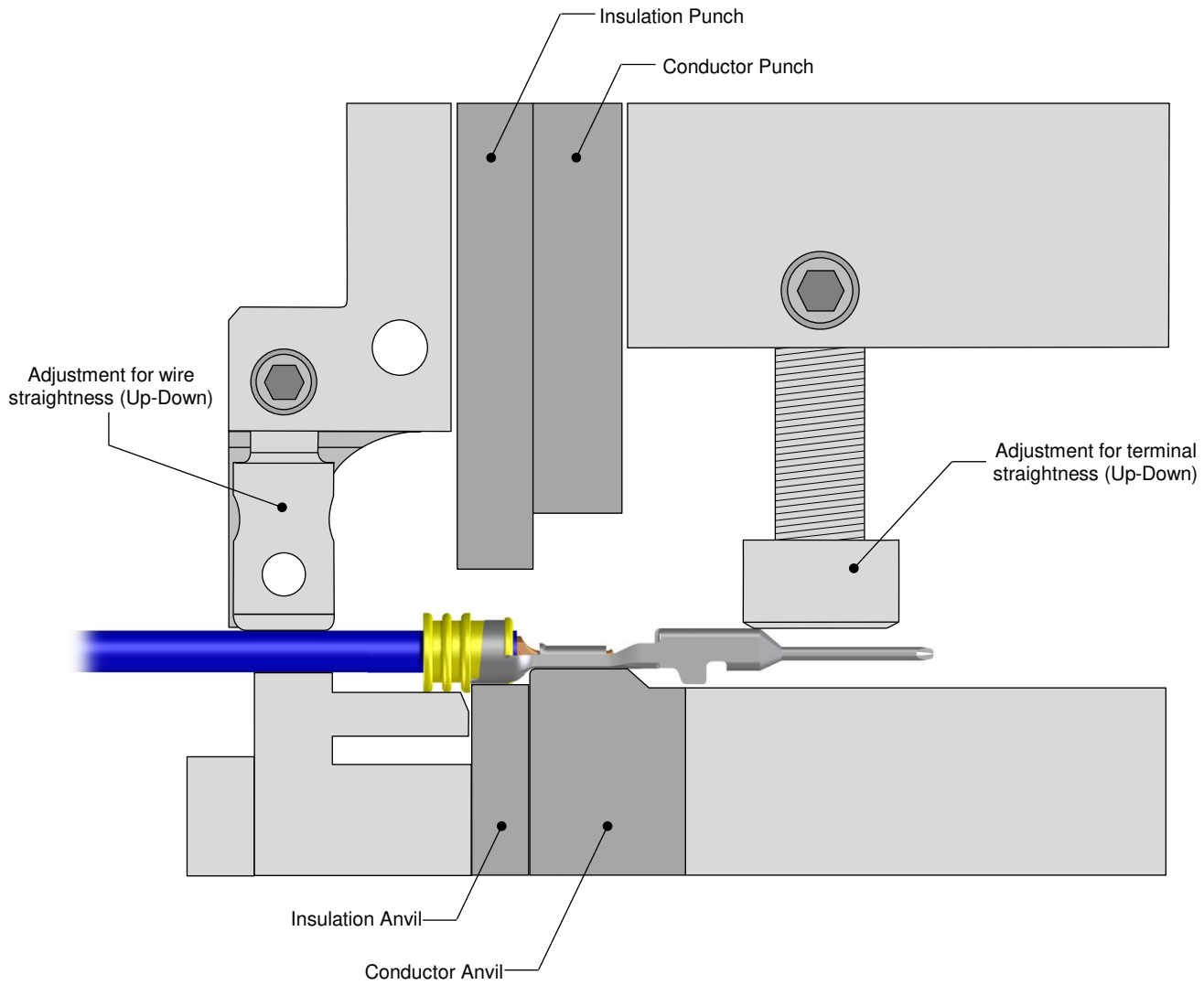

Figure 20

<p>REVISION: B1</p>	<p>ECR/ECN INFORMATION: EC No: UAU2015-0357 DATE: 2014 / 08 / 25</p>	<p>MX150 WIRE SEAL BLADE APPLICATION SPECIFICATION</p>		<p>SHEET No. 17 of 18</p>
<p>DOCUMENT NUMBER: AS-34080-001</p>		<p>CREATED / REVISED BY: B.Jennings</p>	<p>CHECKED BY: A.Dhir</p>	<p>APPROVED BY: B.Moser</p>

8.0 APPLICATION TOOLING

Application Tooling for the Terminal can be obtained directly from Molex.

To find the proper and latest Molex Application Tooling

1. Go to <http://www.molex.com>
2. Enter the terminal / connector part number into the search box and select the "Go" button.
 - a. Molex part numbers can also be found by searching on the product description.
3. Review the Application Tooling available on the right side of the product window.
 - a. It may be necessary to scroll down on the right side of the terminal / connector product page to view all the tooling options.
 - b. Hand tools and manual type tools require the loose terminal / connector part number to be used in the search.
 - c. Applicator or semi-automatic type tools require the reeled terminal / connector part number to be used in the search.
4. Select the tool part number link
5. Review the tooling page for general tool information
6. Open the link for the Application Tooling Specification (ATS) (located on the left under *Specifications & Other Documents*) for additional details such as:
 - a. Termination specifications: crimp height, pull force, wire strip length, insulation diameter, etc.
 - b. Tool information: tool diagram, tool parts list, repair parts, perishable parts list.
7. Order Molex Application Tooling through your preferred distributor

Notes:

1. Hand crimp tooling can only be used with certain wires and terminal part numbers. Check the Application Tooling Specification Sheet on the Molex website for details.
2. Application Tooling product numbers are subject to change without prior notice. Customers are advised to check the Molex website for the most up-to-date information.
3. Molex FineAdjust™ and MiniMac™ Application Tooling requires the use of left payoff ("D" Wind) parts

<u>REVISION:</u> B1	<u>ECR/ECN INFORMATION:</u> EC No: UAU2015-0357 DATE: 2014 / 08 / 25	MX150 WIRE SEAL BLADE APPLICATION SPECIFICATION		<u>SHEET No.</u> 18 of 18
<u>DOCUMENT NUMBER:</u> AS-34080-001		<u>CREATED / REVISED BY:</u> B.Jennings	<u>CHECKED BY:</u> A.Dhir	<u>APPROVED BY:</u> B.Moser