

LOC	DIST	P	F	ZONE	LTR	DESCRIPTION	DATE	APPD
AF	50				L	REV PER OG1A-0418-98	11/25/98	JR/DD
					L1	REV PER ECR-22-142405	24AUG22	VA/EMS

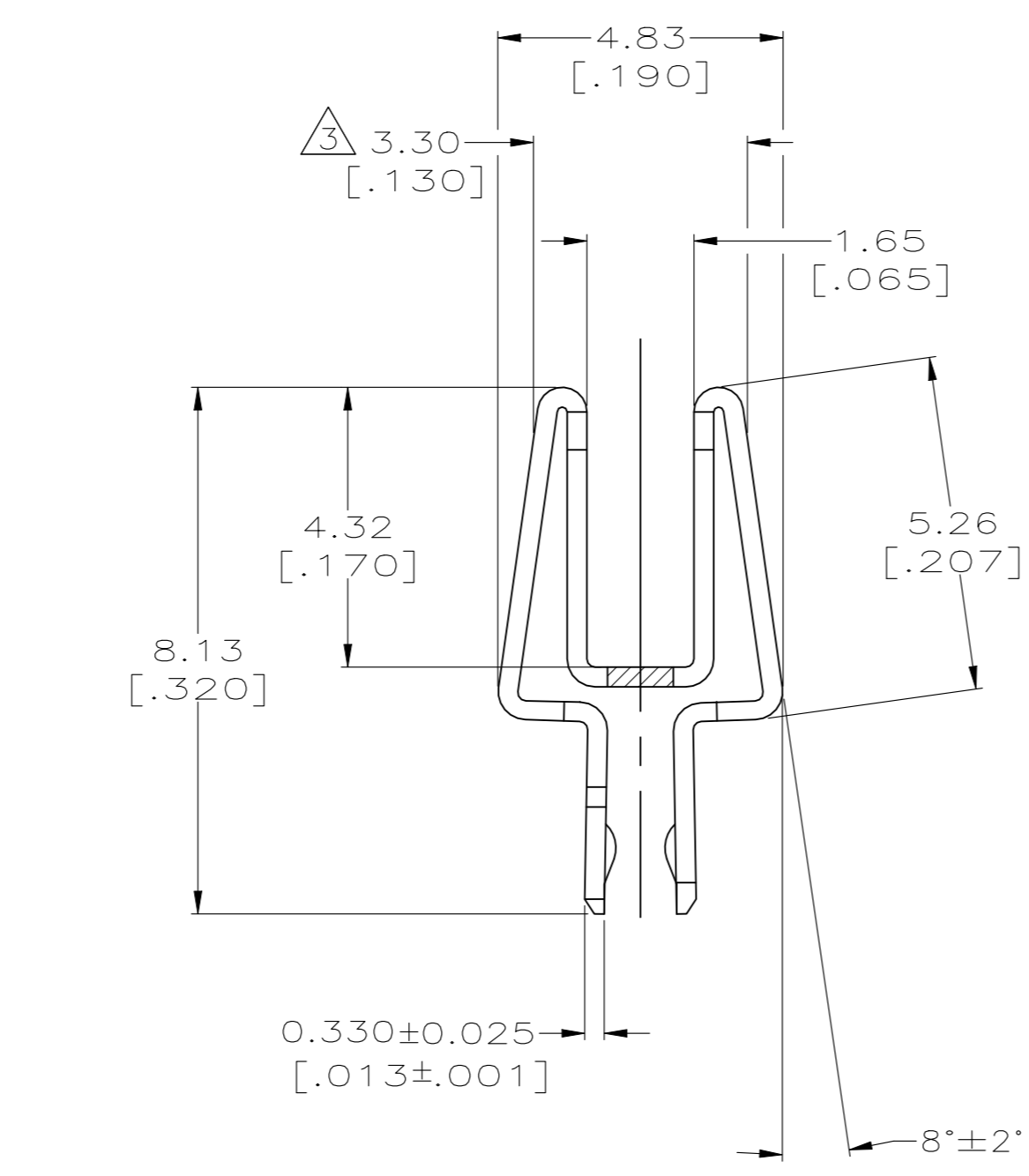
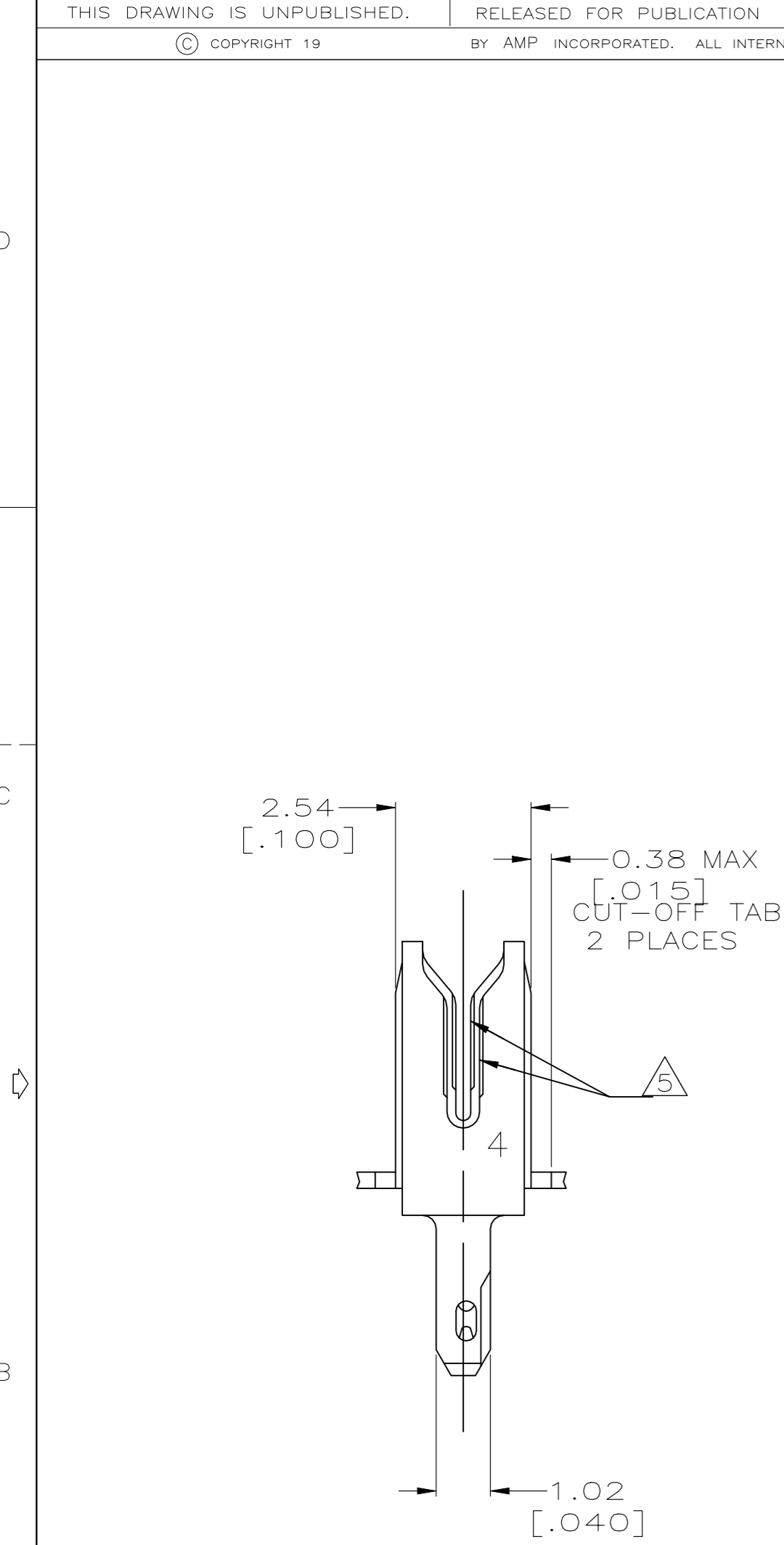

- 1 WIRE TYPES NOT DESCRIBED SHALL BE SUBMITTED TO AMP ENGINEERING FOR WIRE-TO-TERMINAL APPLICATION APPROVAL
- 2 APPLICATION OF TERMINAL INTO P.C.BOARD AND WIRE INSERTION INTO TERMINAL SHALL BE IN ACCORDANCE WITH AMP SPEC.114-2051
- 3 MAXIMUM WIDTH AFTER INSERTION IN P.C. BOARD
- 4 CONTINUOUS STRIP ON REELS WITH TERMINALS LOCATED ON 3.18±0.076[.125±.003] CENTERS
- 5 SLOT ACCEPTS 0.20mm² [#24] AWG 7 STRANDED(TIN PLATED) COPPER WIRE, 0.50-0.40mm [#24-#26] AWG SOLID COPPER WIRE, 0.40mm [#26] AWG FUSED COPPER WIRE.
- 6 0.00381 [.000150] MIN TIN PER MIL-T-10727 OVER 0.00254[.000100] MIN COPPER UNDERPLATE PER MIL-T-14550.
OR
0.00381 [.000150] MIN TIN PER MIL-T-10727 OVER 0.00127 [.000050] MIN NICKEL UNDERPLATE PER QQ-N-290.

OBSOLETE 1.52 [.060]MAX 63007-1

DO NOT SCALE PRINT. UNLESS SPECIFIED DIMENSIONS IN mm [INCHES] TOLERANCES ON :		DR 13/SEPT/95 R.GRZYBOWSKI			
2 PLC DEC ± 0.25[.010]		CHK 13/SEPT/95 M.S.FEHER			
3 PLC DEC ± -		APPD 13/SEPT/95 G.PORTA		NAME TERMINAL, QUADRA-MATE 100 SERIES	
ANGLES ± 1'		APPD 13/SEPT/95 T.L.SHUTTER			
MATERIAL H04 BRASS		PRODUCT SPEC 108-2032		SIZE C 00779	
FINISH 6		APPLICATION SPEC 2		DRAWING NO C-63007	
		WEIGHT -		SCALE 10:1	
				SHEET 10F 1	

THIS DRAWING IS A CONTROLLED DOCUMENT FOR AMP INCORPORATED. IT IS SUBJECT TO CHANGE AND THE CONTROLLING ENGINEERING ORGANIZATION SHOULD BE CONTACTED FOR THE LATEST REVISION.