

NOTE: (A2)

SUITABLE FOR RT360 SERIES 1403 LAYOUT WITHOUT "EC"  
PART NUMBER CONNECTOR

REVISIONS					
REV	ECO	DESCRIPTION	DATE	BY	APPR
A1	-	RELEASED DRAWING	Apr-9-19	Blink	Tommy
A2	-	Add the note	Sep-14-21	Flan	Tommy

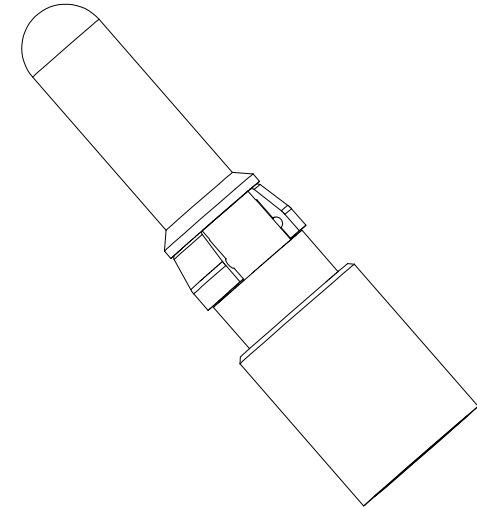
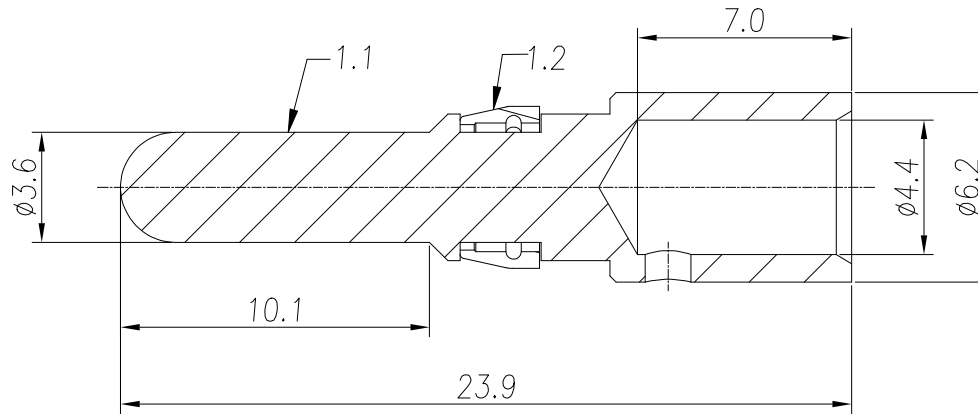

TITLE: EcoMate RM, PIN CONTACT MACHINE, MALE, 3.6mm, (10mm2)  
DWG NO.: MP10A23xx-10  
REV: A2  
SH: 1  
OF: 1

NOTES: (UNLESS OTHERWISE SPECIFIED)

1. MATERIAL:

- 1.1. CONTACT BODY: COPPER ALLOY.
- 1.2. POSITIONING CLIP: COPPER ALLOY.

2. SPECIFICATIONS:

- 2.1 CURRENT RATING: 45A(MAX).
- 2.2 TERMINATION TYPE: CRIMPING.
- 2.3 WIRE RANGE: 8 AWG.

3. SUITABLE SOCKET : MS10A23xx-10.

4. RoHS COMPLIANT.

5. ALL DIMENSIONS ARE FOR REFERENCE USE ONLY.

P/N	CONTACT PLATING(MATING AREA)
MP10A23T-10	TIN PLATING OVER NICKEL.
MP10A23S-10	SILVER PLATING OVER NICKEL.
MP10A23F-10	GOLD FLASH PLATING OVER NICKEL.
MP10A23G5-10	5μ" GOLD PLATING OVER NICKEL.
MP10A23G10-10	10μ" GOLD PLATING OVER NICKEL.
MP10A23G15-10	15μ" GOLD PLATING OVER NICKEL.
MP10A23G30-10	30μ" GOLD PLATING OVER NICKEL.

QUANTITY	PART NUMBER	DESCRIPTION	ITEM
<b>MATERIALS LIST</b>			
<b>UNLESS OTHERWISE SPECIFIED</b> 1) All dimensions are in metric(mm). 2) Tolerances are as follows: 1 PL DEC ±0.30 2 PL DEC ±0.15 3 PL DEC ±0.08 Fractions ±1/64 Angles ±1° 3) Note reference =		<b>SIGNATURES</b> <b>DATE</b> DRAWN: Flan      Sep-14-21 CHECKED: Orion      Sep-15-21 ENGINEER: APPROVAL: Tommy      Sep-15-21 CUSTOMER:	
MATERIAL SPECIFICATIONS:  PROCESS SPECIFICATIONS:  NEXT ASSY:		<div style="text-align: center;">             Sine Systems - www.amphenol-sine.com            44724 Morley Drive            Clinton Township, MI 48036            EcoMate RM, PIN CONTACT            MACHINE, MALE, 3.6mm, (10mm2)         </div>	
THIS DRAWING IS SUPPLIED FOR INFORMATION ONLY. DESIGN FEATURES, SPECIFICATIONS AND PERFORMANCE DATA SHOWN HEREON ARE THE PROPERTY OF THE AMPHENOL CORPORATION. NO RIGHTS OF REPRODUCTION ARE IMPLIED. ALL DIMENSIONS ARE SUBJECT TO NORMAL MANUFACTURING VARIATIONS.		<b>SIZE</b> TYPE DWG NO: <b>B C-</b> MP10A23xx-10	<b>REVISION</b> <b>A2</b>
SCALE: NONE		SHEET 1 OF 1	