

ATLANTIC VERSION TERMINATOR INTERFACE ADAPTER	PART NUMBER	REVISION	DESCRIPTION	FEED TYPE	APPLICATOR STYLE CONVERSION CHART						
					CONVERT TO	PART NUMBERS REQUIRED					
	2266586-1	A	FINE CRIMP HEIGHT ADJUST	MECHANICAL	PNEUMATIC FEED	2119950-1	1338685-1	5-18022-5	2119641-1	2119799-1	2063440-1
					SERVO LATCH PLATE	2119951-1	-	8-2266586-5	1901094-3	-	2168400-6 (QUANTITY 2)
					SMART APPLICATOR	2161326-1	-	8-2266586-4	-	-	-
	2266586-2	A	FINE CRIMP HEIGHT ADJUST	PNEUMATIC	MECHANICAL FEED	2119949-1	1338685-1	5-18022-5	2119653-1	-	-
					SERVO LATCH PLATE	2119951-1	-	8-2266586-5	1901094-3	-	2168400-6 (QUANTITY 2)
	2266586-5	A	FINE CRIMP HEIGHT ADJUST	SERVO LATCH PLATE	SERVO LATCH PLATE	MECHANICAL FEED	2119949-1	1338685-1	5-18022-5	2119653-1	-
						PNEUMATIC FEED	2119950-1	1338685-1	5-18022-5	2119641-1	2119799-1
2266586-6	A	NON-CRIMP HEIGHT ADJUST	SERVO LATCH PLATE	SERVO LATCH PLATE	-	-	-	-	-	-	
2266586-7	A	FINE CRIMP HEIGHT ADJUST	NONE	NONE	-	-	-	-	-	-	
7-2266586-7	A	CRIMP TOOLING KIT	-	-	-	-	-	-	-	-	

APPLICATOR DATA		
CRIMP	SIZE	TYPE
WIRE	1.57 mm [.062]	F
INSUL	2.54 mm [.100]	F

APPLICATOR INSTRUCTIONS
408-10389

TERMINAL DATA: TE TERMINAL		TE CRIMP SPECIFICATION	
TERMINAL NAME: AMP-IN			
WIRE STRIP LENGTH		INSULATION DIAMETER RANGE	
2.88-3.48 mm [.113-.137 IN]		Ø1.52-2.79 mm [.060-.110 IN]	
TERMINAL APPLICATION SPECIFICATION	114-5028		
TERMINALS APPLIED			
TE TERMINAL	TE TERMINAL	TE TERMINAL	TE TERMINAL
170072-1	170072-3	170072-5	

WIRE SIZE	CRIMP HEIGHT mm [INCH]	CRIMP HEIGHT REFERENCE SETTING
20 AWG OR 0.50mm2	0.94+/-0.05 [.037+/-0.002]	6.5
22 AWG OR 0.30mm2	0.89+/-0.05 [.035+/-0.002]	7.0
24 AWG OR 0.20mm2	0.76+/-0.05 [.030+/-0.002]	8.4

- 1 RECOMMENDED SPARE PARTS
- 2 GREASE BEARING SURFACES LIGHTLY
- 3 LUBRICATE DAILY PER THE APPLICATOR INSTRUCTION SHEET SUPPLIED WITH THE APPLICATOR.
- 4 APPLICATOR SPECIFIC DATA TO BE ENTERED INTO BLANK MEMORY CHIP AT ASSEMBLY. SEE BELOW FOR PART NUMBER:
MECHANICAL FEED WITH "SMART APPLICATOR" CONVERSION: 8-2266586-4
PNEUMATIC FEED WITH "SMART APPLICATOR" CONVERSION: 8-2266586-4
SERVO FEED WITH "FINE CRIMP HEIGHT ADJUST": 8-2266586-5
SERVO FEED WITH "NON-CRIMP HEIGHT ADJUST": 8-2266586-6
- 5 ADJUSTMENT OF THE STRIPPER MAY BE REQUIRED WHEN MOVING THE APPLICATOR BETWEEN BENCH AND LEADMAKER APPLICATIONS.
- 6 APPLY PART NUMBER 1-23419-5 LOCTITE TO THREADS OF ITEM 62. APPLY PART NUMBER 2-23419-6 LOCTITE TO THREADS OF ITEM 242. FOR -6 ONLY APPLY PART NUMBER 1-23419-5 LOCTITE TO THREADS OF ITEM 37.
- 7 GREASE THREADS, GROOVE AND O-RING ON ITEMS 35 & 252.
- 8 MAGNET, ITEM 166 MUST BE ORIENTED CORRECTLY IN ORDER TO PROPERLY ACTUATE THE COUNTER.
- 9 CRIMP HEIGHT REFERENCE SETTING WAS THE SETTING USED WHEN THE APPLICATOR WAS QUALIFIED AT THE FACTORY. ADJUSTMENT MAY BE NECESSARY WHEN RUNNING APPLICATOR IN THE FIELD.
- 10 SPARE FEED CAM STORAGE LOCATION REFER TO INSTRUCTION SHEET FOR ADDITIONAL INFORMATION.
- 11 TO CONVERT THE APPLICATOR TO A NON-CARRIER CUTTING STYLE, REMOVE ITEM 13 AND ATTACH TO THE LOCATION ON THE BACK SIDE OF THE HOUSING. REFER TO INSTRUCTION SHEET FOR ADDITIONAL INFORMATION.
- 12 WHEN ASSEMBLING A NON CRIMP HEIGHT ADJUST APPLICATOR (-6) USE SHIMS FROM ITEM 260 TO ACHIEVE A NOMINAL SHIM HEIGHT OF 4.86.

***WARNING**
ON INSTALLATION, SET WIRE DISC, ITEM 40 TO LARGEST WIRE SIZE SETTING. USE OF SETTINGS BELOW MINIMUM REQUIRED CRIMP HEIGHT SETTING WILL CAUSE DAMAGE TO CRIMP TOOLING.

-	-	1	-	-	-	2119957-2	APPLICATOR SHIM PACK	260
-	1	-	1	1	1	8-21084-0	O-RING, .676 ID, .070 DIA. MAT.	252
-	-	-	-	1	-	2119640-1	PUSH ROD, AIR FEED	250
-	-	-	-	1	-	2079988-1	BUSHING, LCH5-12, MISUMI	249
-77	-7	-6	-5	-2	-1	PART NO	DESCRIPTION	ITEM NO

ATLANTIC VERSION
Shown on sheets 1 of 4 & 2 of 4
(Pacific version shown on sheets 3 of 4 & 4 of 4)

SET UP GAUGE	LOC	DIST	REVISIONS					
2119599-1	A	66	P	LTN	DESCRIPTION	DATE	OWN	APVD
			A		RELEASED	08JAN2015	KH	GB

-	-	-	-	1	-	2119641-1	FEED CAM, AIR FEED	248	
-	1	-	1	1	1	2119798-1	DETENT PIN	247	
-	1	-	1	1	1	1-22279-3	SPRING, COMPRESSION	246	
-	-	1	-	-	-	2119758-1	RAM, AMP STYLE, SIDE FEED, NON-ADJ.	245	
-	1	1	1	1	1	2119082-3	CAM, SNAIL, INSULATION ADJUSTMENT	244	
-	1	1	1	1	1	2079764-1	WASHER, WAVE SPRING, CREST-TO-CREST	243	
-	1	1	1	1	1	2119083-1	RETAINER, INSULATION DIAL	242	
-	1	1	1	1	1	7-18023-7	SCR, SKT HD CAP M3 X 4.0	241	
-	-	2	2	-	-	2168400-6	SHCS, LOW HEAD, RoHS, M5 X 16	240	
-	-	-	-	-	1	2119580-1	MECHANICAL FEED ASSEMBLY	239	
-	-	-	-	-	1	2063440-1	AIR FEED MODULE	238	
-	-	1	1	-	-	2119740-2	TAG, IDENTIFICATION	213	
-	-	1	1	-	-	1901094-3	SPACER, FEEDER	198	
-	-	-	-	2	-	21045-3	RING, RETAIN, EXTERN, 3/16 CRESCENT	172	
-	1	1	1	1	1	994969-1	MAGNET, RARE EARTH HIGH ENERGY	166	
-	REF	REF	REF	REF	REF	994970-2	COUNTER, MAGNETIC	164	
-	-	-	-	-	1	240638-1	SPRING, FEED FINGER	163	
-	-	-	-	-	1	3-23627-7	PIN, RETAIN, GRVD, 3/16 X .854	137	
-	-	-	-	-	1	2119799-1	HOLDER, FEED FINGER, AF	136	
-	-	REF	REF	-	-	SEE NOTE 4	MEMORY CHIP, PROGRAMMED	135	
-	-	1	1	-	-	1633743-1	SERVO FEED LATCH ASM	133	
-	-	REF	REF	-	-	2119944-1	FEED FINGER ASSEMBLY, SF	117	
-	1	1	1	1	1	455888-4	SPACER, CRIMPER	82	
-	1	1	1	1	1	22278-8	SPRING, COMPRESSION	77	
-	1	1	1	1	1	854769-4	HOLDER, INS	74	
-	1	1	1	1	1	2119956-1	DOCUMENTATION PACKAGE	71	
-	1	-	-	-	1	2119740-1	TAG, IDENTIFICATION	67	
-	2	2	2	2	2	2168078-1	SCREW, DRIVE, RH, RoHS, 2 x .188	66	
-	1	-	-	1	1	2119793-1	LIMITER, ADJUSTMENT BOLT	63	
-	3	-	3	3	3	992763-5	SCR, SET, SOC, CONE POINT, M3 X 4.0	62	
-	1	1	1	1	1	2079383-4	SCR, BHSC, RoHS (M4 X 8)	60	
-	-	-	-	-	1	5-18022-5	SCR, HEX HD CAP, M4 X 6.0	59	
-	1	1	1	1	1	21028-2	PIN, SLOTTED SPRING .062 X .250	58	
-	-	-	-	-	1	1338685-1	PAWL, FEED	56	
-	4	4	4	4	4	2168400-1	SHCS, LOW HEAD, RoHS, M4 X 12	54	
-	2	2	2	2	2	1-2168083-0	SCR, SKT HD CAP, RoHS, M4 X 10	53	
-	1	1	1	1	1	5018030-1	NUT, HEX, REG, RoHS, M3	52	
-	1	1	1	1	1	811242-5	BUMPER, HOLD DOWN	51	
-	1	1	1	1	1	690753-6	SPACER, TONKER	50	
-	-	-	-	-	1	2	18023-9	SCR, SKT HD CAP M4 X 6.0	49
-	-	-	-	-	-	1	2119652-1	FEED CAM, PRE FEED	48
-	-	-	-	-	-	1	2119653-1	FEED CAM, POST FEED	47
-	1	1	1	1	1	2119656-9	APPLICATOR BASIC ASSEMBLY, SF	46	
-	1	-	-	1	1	2119370-1	RAM, AMP STYLE, SIDE FEED	44	
-	1	1	1	1	1	2079383-7	SCR, BHSC, RoHS (M8 X 25)	41	
-	1	-	-	1	1	2119645-1	DISC, NUMBERED FA WIRE ADJUSTMENT	40	
-	1	-	-	1	1	2119957-1	APPLICATOR SHIM PACK	39	
-	1	1	1	1	1	1-2119644-4	RAM WASHER, PRECISION	38	
-	1	1	1	1	1	2119085-1	FA HEAD, ATLANTIC STYLE	37	
-	1	-	-	1	1	2119092-1	BOLT, ADJUSTMENT	35	
-	1	1	1	1	1	2-1752356-4	SUPPORT, TERMINAL	34	
-	2	2	2	2	2	2079383-5	SCR, BHSC, RoHS (M4 X 20)	33	
-	1	1	1	1	1	2161328-1	HEX HEAD, FLANGED, M5 X 8mm LONG	32	
-	1	1	1	1	1	1320908-3	SPACER, STRIP GUIDE	30	
-	1	1	1	1	1	2119959-1	ASSEMBLY, STRIP GUIDE	29	
-	1	1	1	1	1	455888-3	SPACER, CRIMPER	28	
-	1	1	1	1	1	1320928-2	STRIP GUIDE	24	
-	1	1	1	1	1	2168083-2	SCR, SKT HD CAP, RoHS, M4 X 8.0	21	
-	2	2	2	2	2	1-18028-2	WASHER, FLAT, REG M4	20	
-	1	1	1	1	1	2119533-3	STRIPPER, SIDE FEED	19	
-	1	1	1	1	1	2119806-1	INSERT, SHEAR	13	
-	1	1	1	1	1	3-22280-3	SPRING, COMPRESSION	12	
-	1	1	1	1	1	1-356885-4	STOP, SHEAR	11	
-	1	1	1	1	1	2119805-1	SHEAR HOLDER, FRONT	10	
-	1	1	1	1	1	1803095-1	FLOATING SHEAR, FRONT	9	
1	1	1	1	1	1	5-1633129-0	ANVIL, COMBINATION .062	8	
-	-	-	-	-	-	-	-	7	
-	-	-	-	-	-	-	-	6	
-	1	1	1	1	1	2119780-9	DEPRESSOR, SHEAR	5	
-	1	1	1	1	1	2-238011-2	BLOCK, CRIMPER SPACER	4	
1	1	1	1	1	1	7-1633962-4	CRIMPER, INSULATION F PREMIUM	3	
-	1	1	1	1	1	455888-3	SPACER, CRIMPER	2	
1	1	1	1	1	1	3-456403-2	CRIMPER, WIRE PREMIUM	1	
-77	-7	-6	-5	-2	-1	PART NO	DESCRIPTION	ITEM NO	

DIMENSIONS:		TOLERANCES UNLESS OTHERWISE SPECIFIED:		MATERIAL:		FINISH:		WEIGHT:		SCALE:	
mm	0 PLC ±.5	1 PLC ±0.5	2 PLC ±0.13	3 PLC ±0.013	4 PLC ±0.0001	ANGLES	±.1				

LOC		DIST		REVISIONS			
A	66	P	LTM	DESCRIPTION	DATE	DWN	APVD
		-	-	SEE SHEET 1	-	-	-

FEED TYPE MECHANICAL



PNEUMATIC

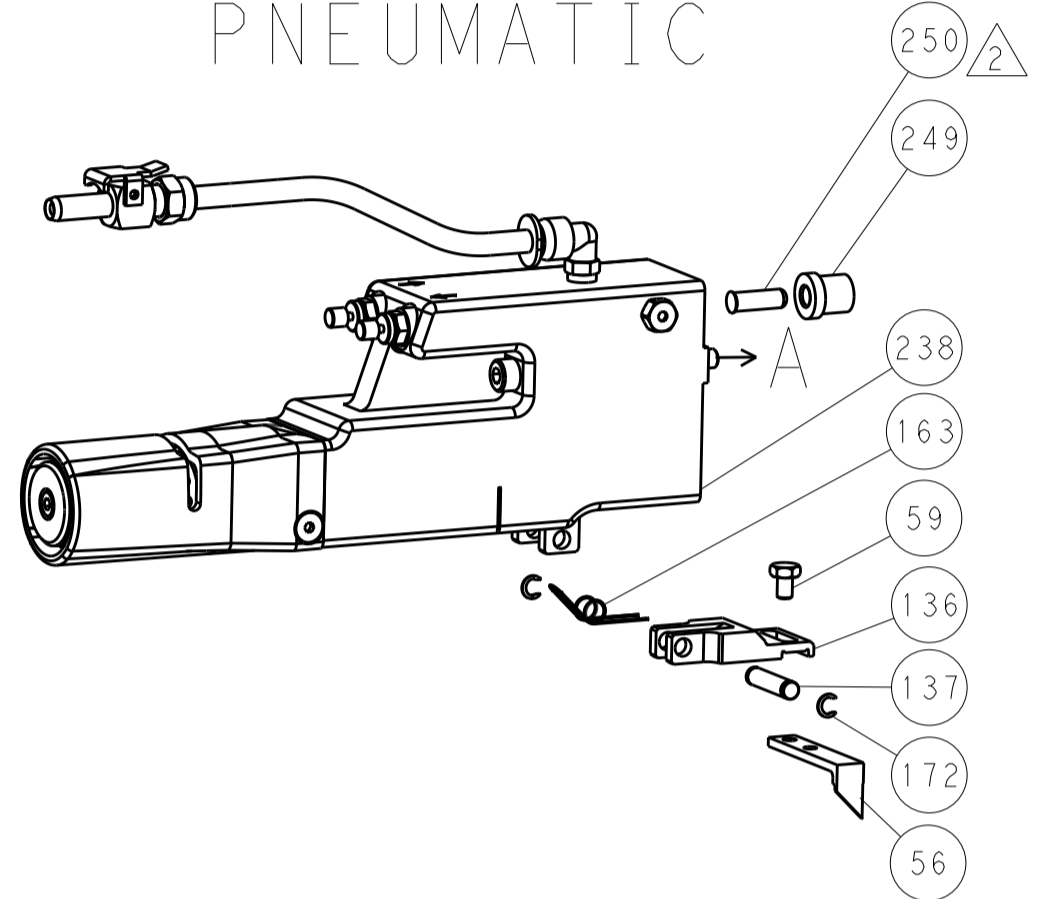

SERVO LATCH PLATE

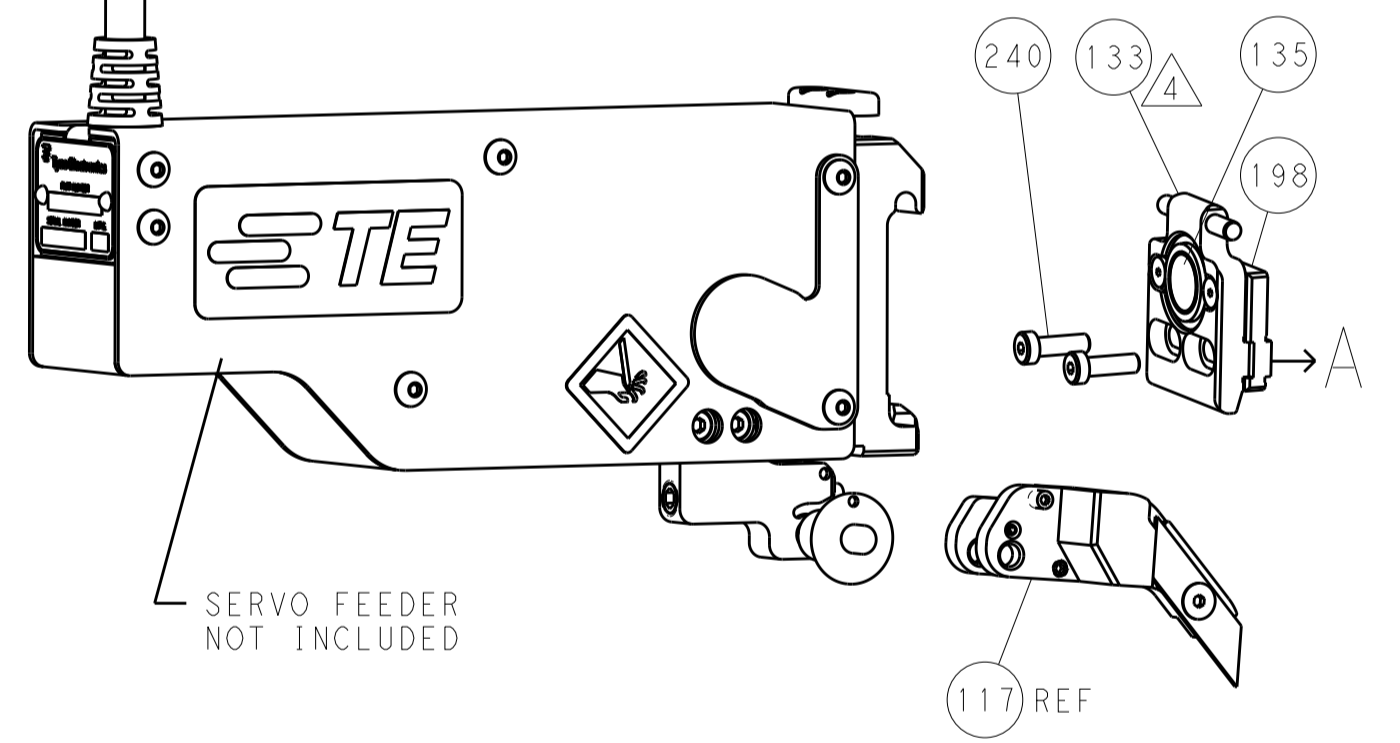

CAM POSITIONS

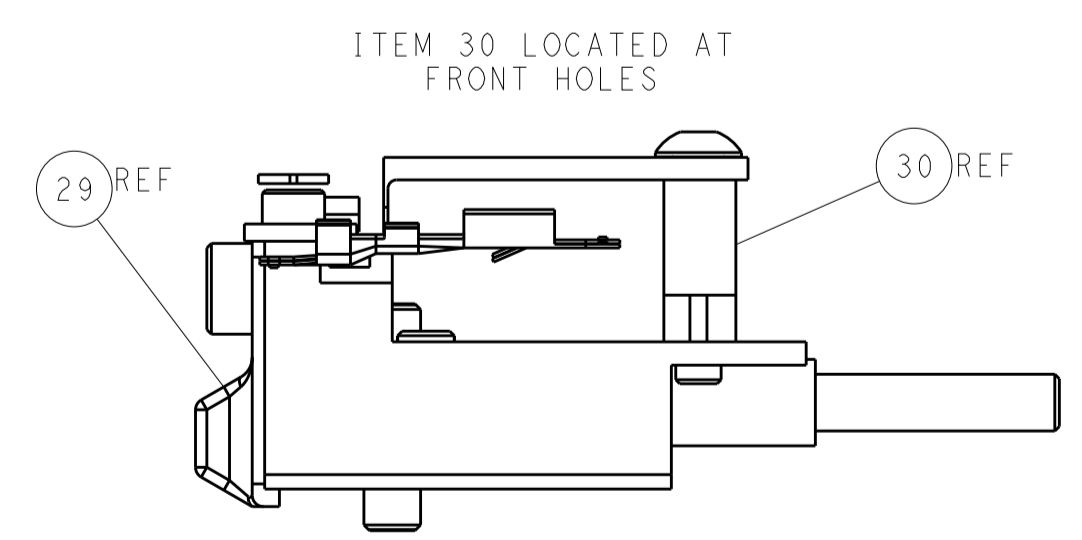
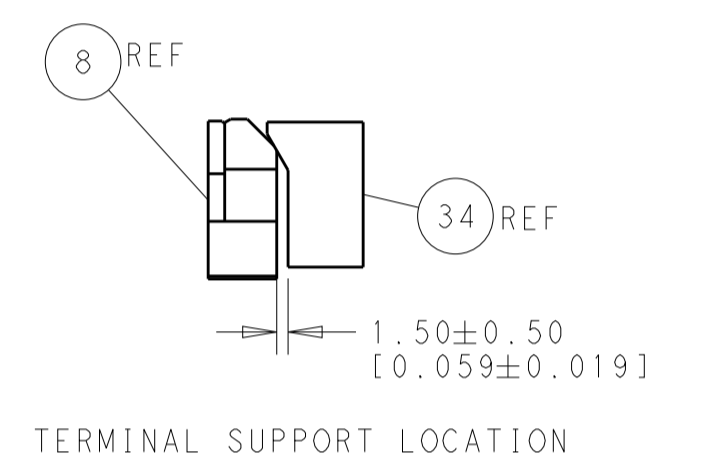
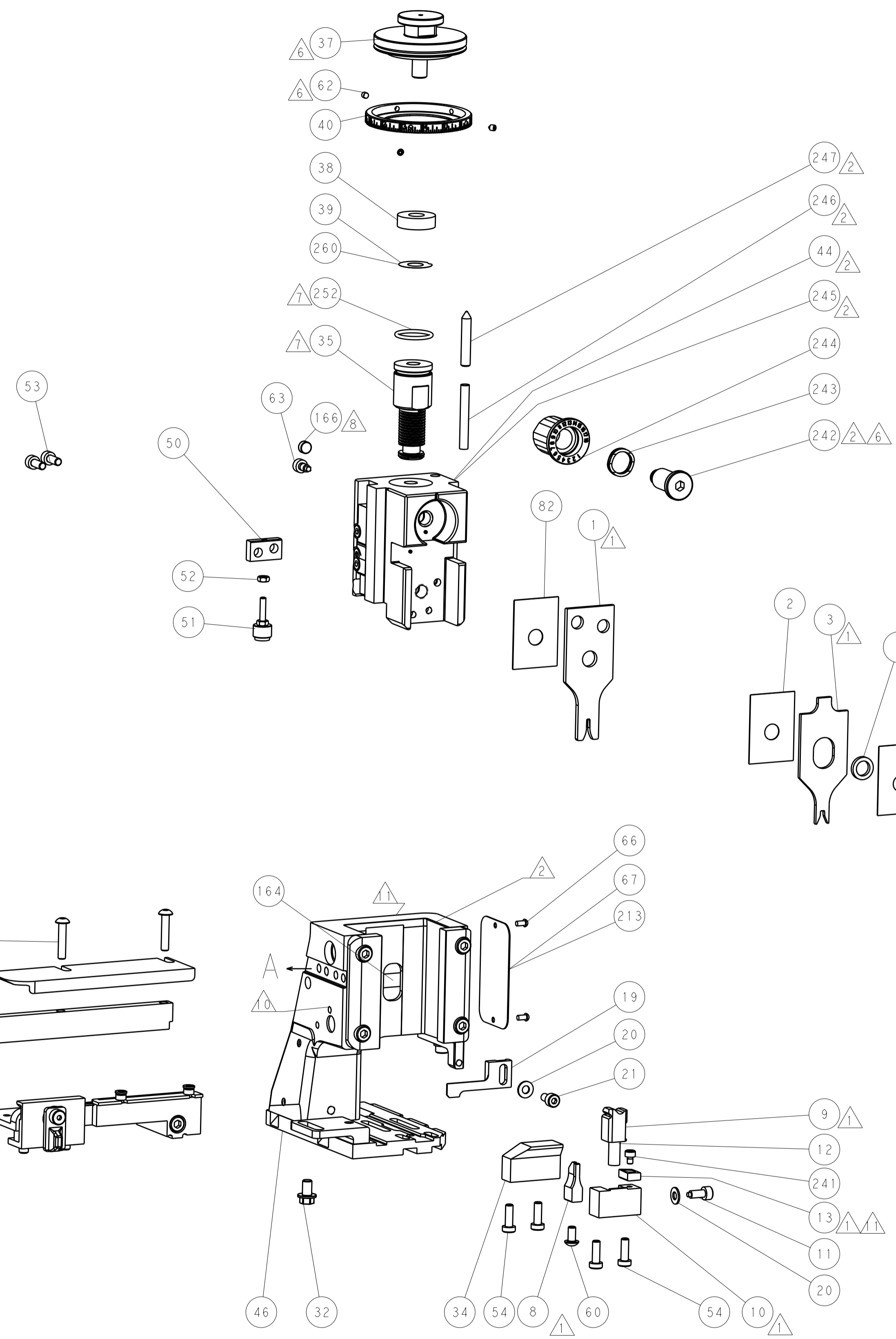

FEED TRACK POSITION GUIDE BY INSULATION BARREL

ATLANTIC VERSION
 Shown on sheets 1 of 4 & 2 of 4
 (Pacific version shown on sheets 3 of 4 & 4 of 4)

DIMENSIONS:		TOLERANCES UNLESS OTHERWISE SPECIFIED:		DWN H. HUANG 25NOV2014		TE Connectivity	
mm	0 PLC ±0.5	1 PLC ±0.5	2 PLC ±0.13	3 PLC ±0.013	4 PLC ±0.0001	APVD L. ZHANG 25NOV2014	Harrisburg, PA 17105-3608
MATERIAL:		FINISH:		NAME Ocean Side Feed Applicator		RESTRICTED TO	
				SIZE CAGE CODE DRAWING NO. A11 00779 ©=2266586		SCALE 1:2 SHEET 2 OF 4 REV A	

PACIFIC VERSION TERMINATOR INTERFACE ADAPTER	PART NUMBER	REVISION	DESCRIPTION	FEED TYPE	APPLICATOR STYLE CONVERSION CHART						
					CONVERT TO	PART NUMBERS REQUIRED					
	2-2266586-1	A	FINE CRIMP HEIGHT ADJUST	MECHANICAL	PNEUMATIC FEED	2119950-1	1338685-1	5-18022-5	2119641-2	2119799-1	2063440-1
					SERVO LATCH PLATE	2119951-1	-	8-2266586-5	1901094-3	-	2168400-6 (QUANTITY 2)
					SMART APPLICATOR	2161326-1	-	8-2266586-4	-	-	-
	2-2266586-2	A	FINE CRIMP HEIGHT ADJUST	PNEUMATIC	MECHANICAL FEED	2119949-1	1338685-1	5-18022-5	2119653-2	-	-
					SERVO LATCH PLATE	2119951-1	-	8-2266586-5	1901094-3	-	2168400-6 (QUANTITY 2)
					SMART APPLICATOR	2161326-1	-	8-2266586-4	-	-	-
	2-2266586-5	A	FINE CRIMP HEIGHT ADJUST	SERVO LATCH PLATE	MECHANICAL FEED	2119949-1	1338685-1	5-18022-5	2119653-2	-	-
					PNEUMATIC FEED	2119950-1	1338685-1	5-18022-5	2119641-2	2119799-1	2063440-1
	2-2266586-7	A	FINE CRIMP HEIGHT ADJUST	NONE	-	-	-	-	-	-	-
	7-2266586-7	A	CRIMP TOOLING KIT	-	-	-	-	-	-	-	-

APPLICATOR DATA		
CRIMP	SIZE	TYPE
WIRE	1.57 mm [.062]	F
INSUL	2.54 mm [.100]	F
APPLICATOR INSTRUCTIONS 408-10389		

TERMINAL DATA: TE TERMINAL		TE CRIMP SPECIFICATION	
TERMINAL NAME: AMP-IN			
WIRE STRIP LENGTH		INSULATION DIAMETER RANGE	
2.88-3.48 mm [.113-.137 IN]		Ø1.52-2.79 mm [.060-.110 IN]	
TERMINAL APPLICATION SPECIFICATION	114-5028	-	-
TERMINALS APPLIED			
TE TERMINAL	TE TERMINAL	TE TERMINAL	TE TERMINAL
170072-1	170072-3	170072-5	

WIRE SIZE	CRIMP HEIGHT mm [INCH]	CRIMP HEIGHT REFERENCE SETTING
20 AWG OR 0.50mm2	0.94+/-0.05 [.037+/-0.002]	6.5
22 AWG OR 0.30mm2	0.89+/-0.05 [.035+/-0.002]	7.0
24 AWG OR 0.20mm2	0.76+/-0.05 [.030+/-0.002]	8.4

- RECOMMENDED SPARE PARTS
- GREASE BEARING SURFACES LIGHTLY
- LUBRICATE DAILY PER THE APPLICATOR INSTRUCTION SHEET SUPPLIED WITH THE APPLICATOR.
- APPLICATOR SPECIFIC DATA TO BE ENTERED INTO BLANK MEMORY CHIP AT ASSEMBLY. SEE BELOW FOR PART NUMBER:
 MECHANICAL FEED WITH "SMART APPLICATOR" CONVERSION: 8-2266586-4
 PNEUMATIC FEED WITH "SMART APPLICATOR" CONVERSION: 8-2266586-4
 SERVO FEED WITH "FINE CRIMP HEIGHT ADJUST": 8-2266586-5
- ADJUSTMENT OF THE STRIPPER MAY BE REQUIRED WHEN MOVING THE APPLICATOR BETWEEN BENCH AND LEADMAKER APPLICATIONS.
- APPLY PART NUMBER 1-23419-5 LOCTITE TO THREADS OF ITEM 62.
 APPLY PART NUMBER 2-23419-6 LOCTITE TO THREADS OF ITEM 242.
- GREASE THREADS, GROOVE AND O-RING ON ITEMS 139 & 152.
- MAGNET MUST BE ORIENTED CORRECTLY IN ORDER TO PROPERLY ACTUATE THE COUNTER.
- CRIMP HEIGHT REFERENCE SETTING WAS THE SETTING USED WHEN THE APPLICATOR WAS QUALIFIED AT THE FACTORY. ADJUSTMENT MAY BE NECESSARY WHEN RUNNING APPLICATOR IN THE FIELD.
- SPARE FEED CAM STORAGE LOCATION REFER TO INSTRUCTION SHEET FOR ADDITIONAL INFORMATION.
- TO CONVERT THE APPLICATOR TO A NON-CARRIER CUTTING STYLE, REMOVE ITEM 13 AND ATTACH TO THE LOCATION ON BACK SIDE OF THE HOUSING. REFER TO INSTRUCTION SHEET FOR ADDITIONAL INFORMATION.

***WARNING**
 ON INSTALLATION, SET WIRE DISC, ITEM 40 TO LARGEST WIRE SIZE SETTING. USE OF SETTINGS BELOW MINIMUM REQUIRED CRIMP HEIGHT SETTING WILL CAUSE DAMAGE TO CRIMP TOOLING.

-77	-27	-25	-22	-21	PART NO	DESCRIPTION	ITEM NO
-	1	1	1	1	2119782-1	FINE ADJUST HEAD ASM, PACIFIC STYLE	251
-	-	-	1	-	2119640-1	PUSH ROD, AIR FEED	250

PACIFIC VERSION
 Shown on sheets 3 of 4 & 4 of 4
 (Atlantic version shown on sheets 1 of 4 & 2 of 4)

SET UP GAUGE	LOC	DIST	REVISIONS					
2119599-1	A	66	P	LTN	DESCRIPTION	DATE	OWN	APVD
			-	-	SEE SHEET 1	-	-	-

-	-	-	1	-	2079988-1	BUSHING, LCH5-12, MISUMI	249
-	1	1	1	1	1-22279-3	SPRING, COMPRESSION	246
-	1	1	1	1	2119082-3	CAM, SNAIL, INSULATION ADJUSTMENT	244
-	1	1	1	1	2079764-1	WASHER, WAVE SPRING, CREST-TO-CREST	243
-	1	1	1	1	2119083-1	RETAINER, INSULATION DIAL	242
-	1	1	1	1	7-18023-7	SCR, SKT HD CAP M3 X 4.0	241
-	-	2	-	-	2168400-6	SHCS, LOW HEAD, RoHS, M5 X 16	240
-	-	-	-	1	2119580-1	MECHANICAL FEED ASSEMBLY	239
-	-	-	-	1	2063440-1	AIR FEED MODULE	238
-	-	1	-	-	2119740-2	TAG, IDENTIFICATION	213
-	-	1	-	-	1901094-3	SPACER, FEEDER	198
-	-	-	2	-	21045-3	RING, RETAIN, EXTERN, 3/16 CRESCENT	172
-	1	1	1	1	994969-1	MAGNET, RARE EARTH HIGH ENERGY	166
-	REF	REF	REF	REF	994970-2	COUNTER, MAGNETIC	164
-	-	-	1	-	240638-1	SPRING, FEED FINGER	163
-	1	1	1	1	8-21084-1	O-RING, .801 ID, .070 DIA. MAT.	152
-	-	-	1	-	2119641-2	FEED CAM, AIR FEED	151
-	1	1	1	1	2119798-2	DETENT PIN	145
-	1	1	1	1	2079383-8	SCR, BHSC, RoHS (M4 X 16)	144
-	4	4	4	4	2168400-5	SHCS, LOW HEAD, RoHS, M4 X 20	143
-	-	-	-	1	2119653-2	FEED CAM, POST FEED	142
-	1	1	1	1	1-2119656-0	APPLICATOR BASIC ASSEMBLY, SF	141
-	1	1	1	1	2119650-1	RAM, ASIAN STYLE, SIDE FEED	140
-	1	1	1	1	2119092-2	BOLT, ADJUSTMENT	139
-	-	-	1	-	3-23627-7	PIN, RETAIN, GRVD, 3/16 X .854	137
-	-	-	1	-	2119799-1	HOLDER, FEED FINGER, AF	136
-	-	REF	-	-	SEE NOTE 4	MEMORY CHIP, PROGRAMMED	135
-	-	1	-	-	1633743-1	SERVO FEED LATCH ASM	133
-	-	REF	-	-	2119944-1	FEED FINGER ASSEMBLY, SF	117
-	1	1	1	1	455888-4	SPACER, CRIMPER	82
-	1	1	1	1	22278-8	SPRING, COMPRESSION	77
-	1	1	1	1	854769-4	HOLDER, INS	74
-	1	1	1	1	2119956-1	DOCUMENTATION PACKAGE	71
-	1	-	1	1	2119740-1	TAG, IDENTIFICATION	67
-	2	2	2	2	2168078-1	SCREW, DRIVE, RH, RoHS, 2 x .188	66
-	1	1	1	1	2119793-1	LIMITER, ADJUSTMENT BOLT	63
-	3	3	3	3	992763-5	SCR, SET, SOC, CONE POINT, M3 x 4.0	62
-	-	-	1	1	5-18022-5	SCR, HEX HD CAP, M4 X 6.0	59
-	1	1	1	1	21028-2	PIN, SLOTTED SPRING .062 X .250	58
-	-	-	1	1	1338685-1	PAWL, FEED	56
-	2	2	2	2	1-2168083-0	SCR, SKT HD CAP, RoHS, M4 X 10	53
-	1	1	1	1	5018030-1	NUT, HEX, REG, RoHS, M3	52
-	1	1	1	1	811242-5	BUMPER, HOLD DOWN	51
-	1	1	1	1	690753-6	SPACER, TONKER	50
-	-	-	1	2	18023-9	SCR, SKT HD CAP M4 X 6.0	49
-	-	-	-	1	2119652-1	FEED CAM, PRE FEED	48
-	1	1	1	1	2079383-7	SCR, BHSC, RoHS (M8 X 25)	41
-	1	1	1	1	2119645-1	DISC, NUMBERED FA WIRE ADJUSTMENT	40
-	1	1	1	1	2119957-1	APPLICATOR SHIM PACK	39
-	1	1	1	1	1-2119644-4	RAM WASHER, PRECISION	38
-	1	1	1	1	2-1752356-4	SUPPORT, TERMINAL	34
-	2	2	2	2	2079383-5	SCR, BHSC, RoHS (M4 X 20)	33
-	1	1	1	1	2161328-1	HEX HEAD, FLANGED, M5 x 8mm LONG	32
-	1	1	1	1	1320908-3	SPACER, STRIP GUIDE	30
-	1	1	1	1	2119959-1	ASSEMBLY, STRIP GUIDE	29
-	1	1	1	1	455888-3	SPACER, CRIMPER	28
-	1	1	1	1	1320928-2	STRIP GUIDE	24
-	1	1	1	1	2168083-2	SCR, SKT HD CAP, RoHS, M4 X 8.0	21
-	2	2	2	2	1-18028-2	WASHER, FLAT, REG M4	20
-	1	1	1	1	2119533-3	STRIPPER, SIDE FEED	19
-	1	1	1	1	2119806-1	INSERT, SHEAR	13
-	1	1	1	1	3-22280-3	SPRING, COMPRESSION	12
-	1	1	1	1	1-356885-4	STOP, SHEAR	11
-	1	1	1	1	2119805-1	SHEAR HOLDER, FRONT	10
-	1	1	1	1	1803095-1	FLOATING SHEAR, FRONT	9
-	1	1	1	1	5-1633129-0	ANVIL, COMBINATION .062	8
-	-	-	-	-	-	-	7
-	-	-	-	-	-	-	6
-	1	1	1	1	2119780-9	DEPRESSOR, SHEAR	5
-	1	1	1	1	2-238011-2	BLOCK, CRIMPER SPACER	4
-	1	1	1	1	7-1633962-4	CRIMPER, INSULATION F PREMIUM	3
-	1	1	1	1	455888-3	SPACER, CRIMPER	2
-	1	1	1	1	3-456403-2	CRIMPER, WIRE PREMIUM	1

DIMENSIONS:		TOLERANCES UNLESS OTHERWISE SPECIFIED:		OWN	CHK	DATE	NAME	
mm	0 PLC ±.5	1 PLC ±.5	2 PLC ±.13	H. HUANG	L. ZHANG	25NOV2014	TE Connectivity	
	3 PLC ±.013	4 PLC ±.001	ANGLES ±.0001	J. GUO		25NOV2014	Harrisburg, PA 17105-3608	
MATERIAL	FINISH	WEIGHT	SCALE	PRODUCT SPEC		Ocean Side Feed Applicator		
			1:2	APPLICATION SPEC		SIZE CASE CODE DRAWING NO RESTRICTED TO		
				APPLICATOR SPEC		A1 00779 C=2266586		
				MATERIAL		Customer Accessible Production Drawing		
				FINISH		SHEET 3 OF 4 REV A		

LOC		DIST		REVISIONS			
A	66	P	LTM	DESCRIPTION	DATE	DWN	APVD
		-		SEE SHEET 1			

FEED TYPE MECHANICAL



PNEUMATIC

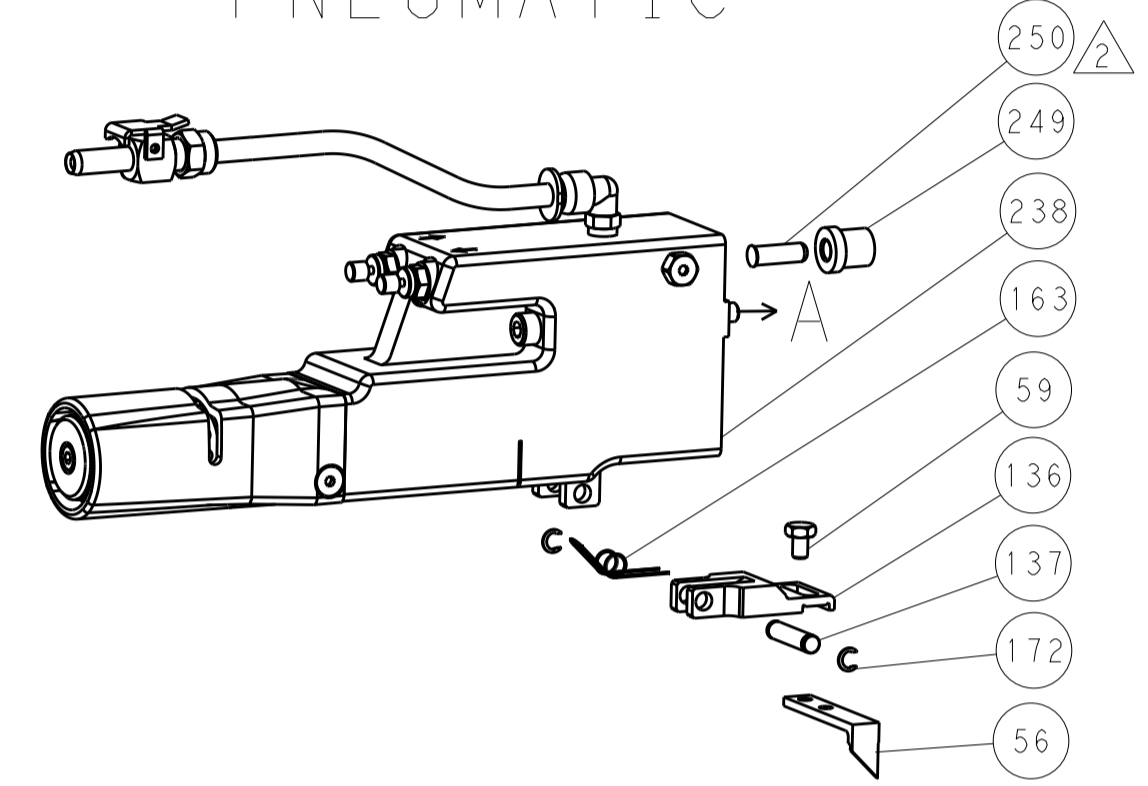

SERVO LATCH PLATE



CAM POSITIONS

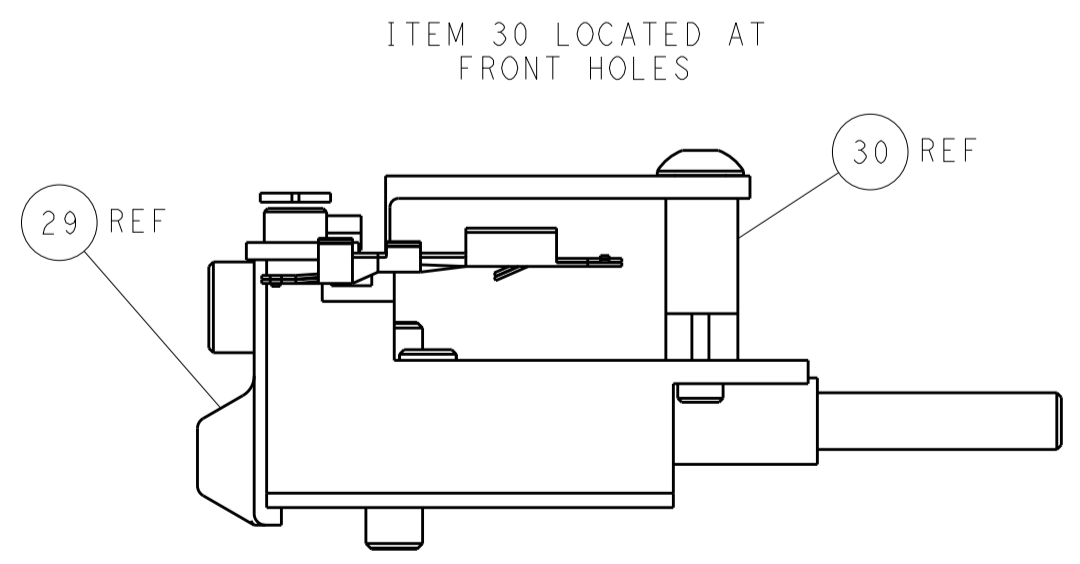
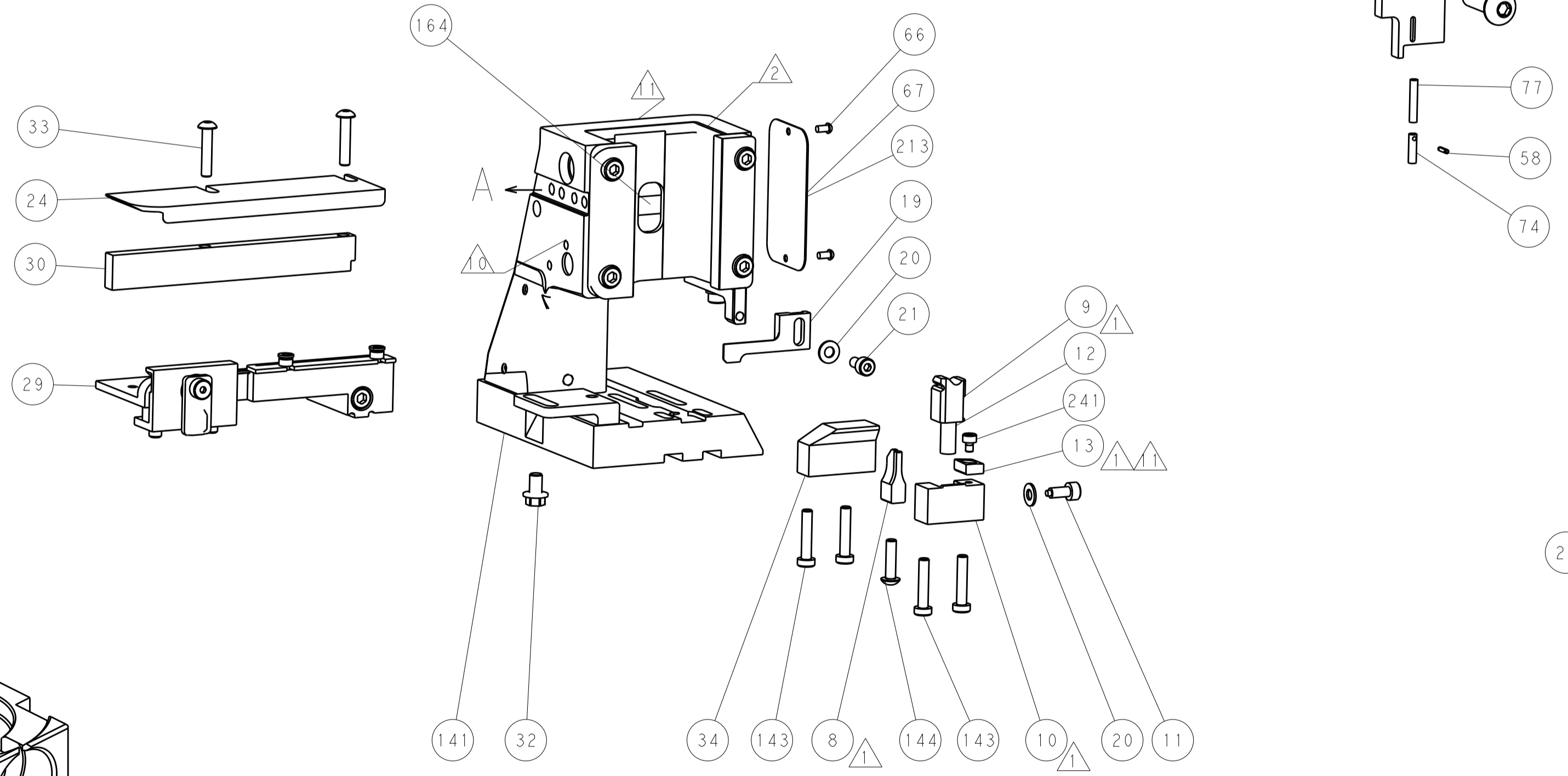
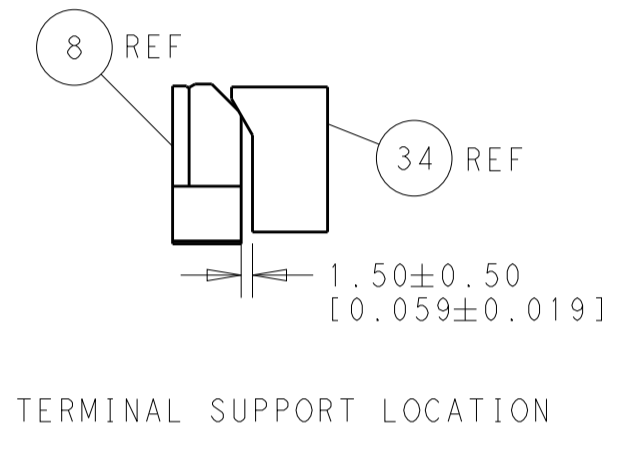
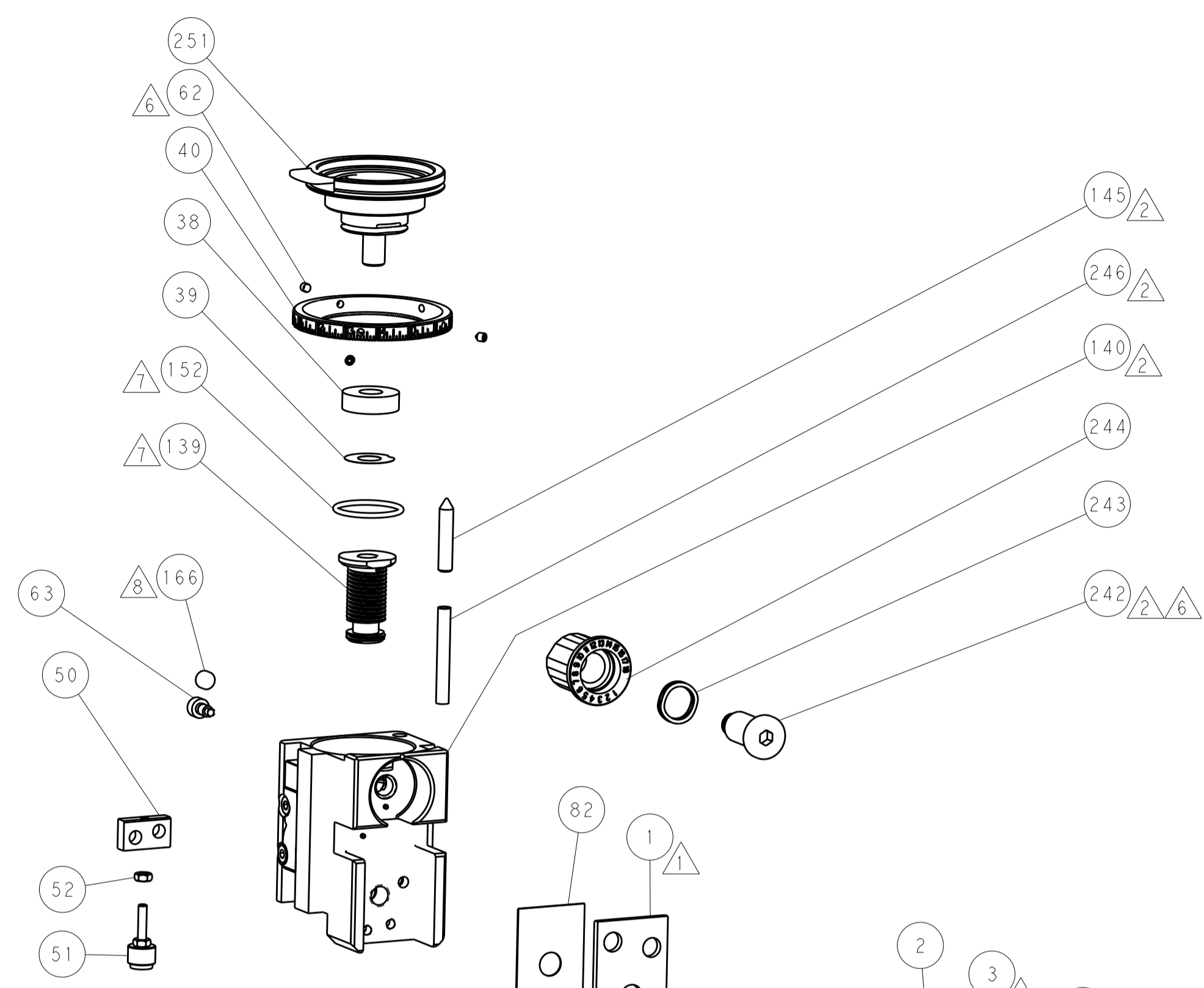
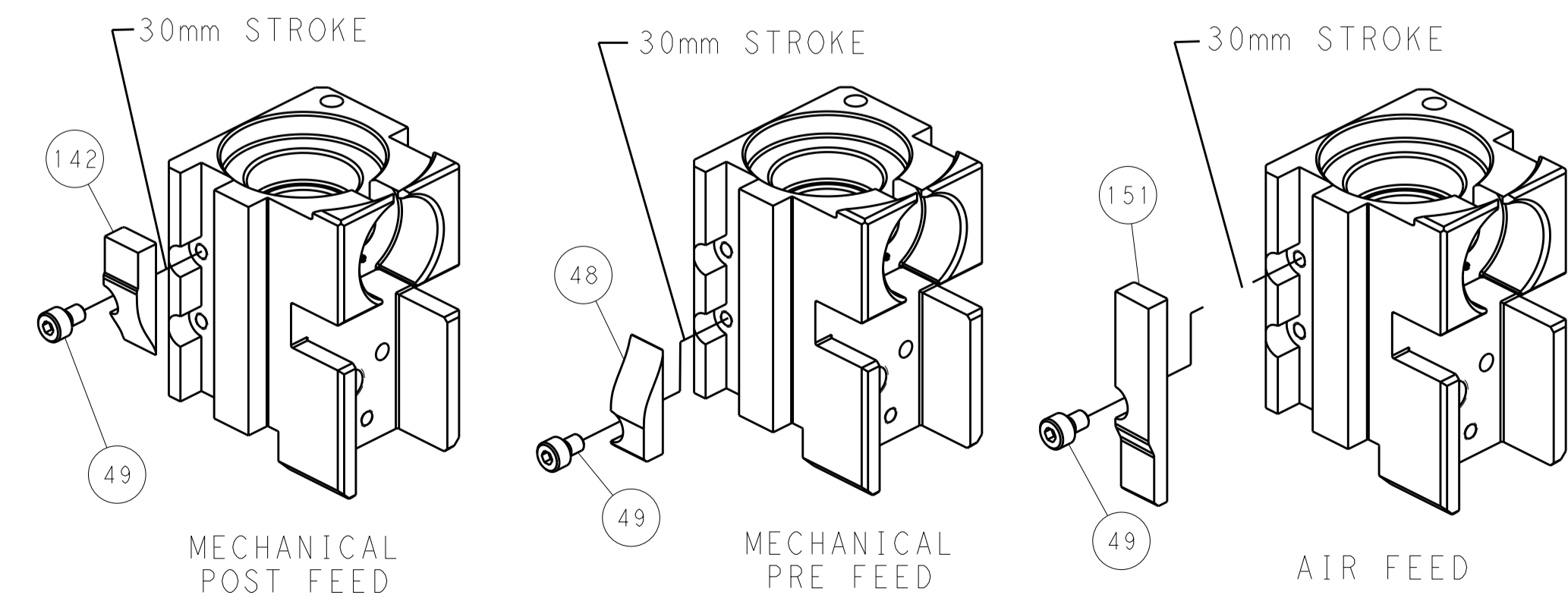

FEED TRACK POSITION GUIDE BY INSULATION BARREL

PACIFIC VERSION
 Shown on sheets 3 of 4 & 4 of 4
 (Atlantic version shown on sheets 1 of 4 & 2 of 4)

DIMENSIONS:		TOLERANCES UNLESS OTHERWISE SPECIFIED:		DWN: H. HUANG 25NOV2014		CHK: L. ZHANG 25NOV2014		APVD: H. GUO 25NOV2014		NAME: Ocean Side Feed Applicator	
mm	0 PLC ±0.5	1 PLC ±0.5	2 PLC ±0.13	3 PLC ±0.013	4 PLC ±0.001	ANGLES	FINISH	WEIGHT	SCALE	SHEET	REV
									1:2	4	A
Customer Accessible Production Drawing										RESTRICTED TO	