

WIRELESS M-BUS DEMONSTRATION KIT USER'S GUIDE

1. Kit Contents

The Wireless M-Bus Demonstration Kit contains the following items:

- Wireless M-Bus Demonstration Board
- 3.6 V Lithium battery
- USB cable
- AC to DC power adapter
- 868 MHz antenna

2. Introduction

The purpose of the Wireless M-Bus Demonstration Kit is to demonstrate a low-power meter application using the Wireless M-Bus stack. The demonstration has three basic system components:

- Wireless M-Bus Meter Demonstration Kit (Meter)
- Monitor
- PC Application

The Wireless M-Bus Meter Demonstration Kit performs the basic metering functions. It will either count pulses or measure the temperature. The Meter will also periodically wake up and transmit the data using the Wireless M-Bus protocol.

The Monitor measures and displays the current consumption of the Meter. The Monitor also communicates with the PC application and configures the Meter over a UART connection.

The Wireless M-Bus Demonstration board is shown in Figure 1. The right half of the board implements the Meter, and the left half of the board implements the Monitor.



Figure 1. Wireless M-Bus Demonstration Board

Wireless M-Bus-EK

3. Hardware Overview

The Wireless M-Bus Demo board has two sections. The Wireless M-Bus meter section is on the right half as shown in Figure 2.

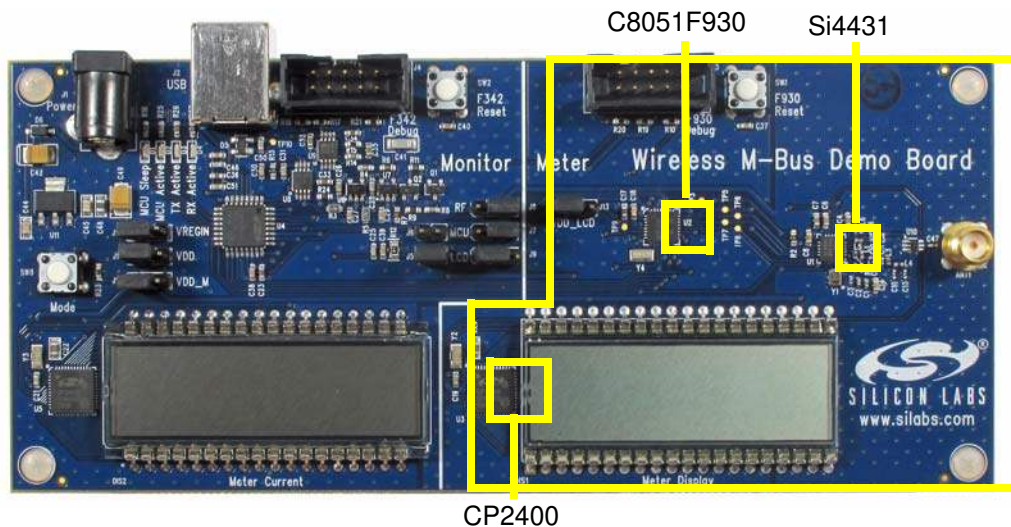

Figure 2. Meter Section

The Wireless M-Bus meter section includes the following components.

- C8051F930 Low-Power Microcontroller
- Si4431 EZRadioPRO[®] Transceiver
- CP2400 LCD Driver

The C8051F930 is well suited for Low-Power Metering solutions. This MCU includes 64 k of Flash and 4 k of RAM, which is sufficient for the Wireless M-Bus stack and a large application. The C8051F930 has a very low-power Sleep mode. The current consumption in Sleep mode is only 50 nA. The MCU also has a 32.768 kHz SmaRTClock[™]. The MCU SmaRTClock[™] is used for all timing functions in the low-power meter.

The Si4431 EZRadioPRO[®] transceiver provides +13 dB of output power. This is the highest power permitted in the 868 MHz band used by the Wireless M-Bus Standard. The RF layout is matched for 868 MHz. The Si4431 is placed in Shutdown mode when the radio is not in use. The current draw in shutdown mode is only 15 nA.

The CP2400 LCD driver features an SPI interface and can drive displays with up to 128 segments and four backplanes. The Wireless M-Bus meter section uses a static four-digit display for the lowest possible power consumption. The Meter Display is used to display either pulse count or Temperature. The Monitor Section is shown in Figure 3.

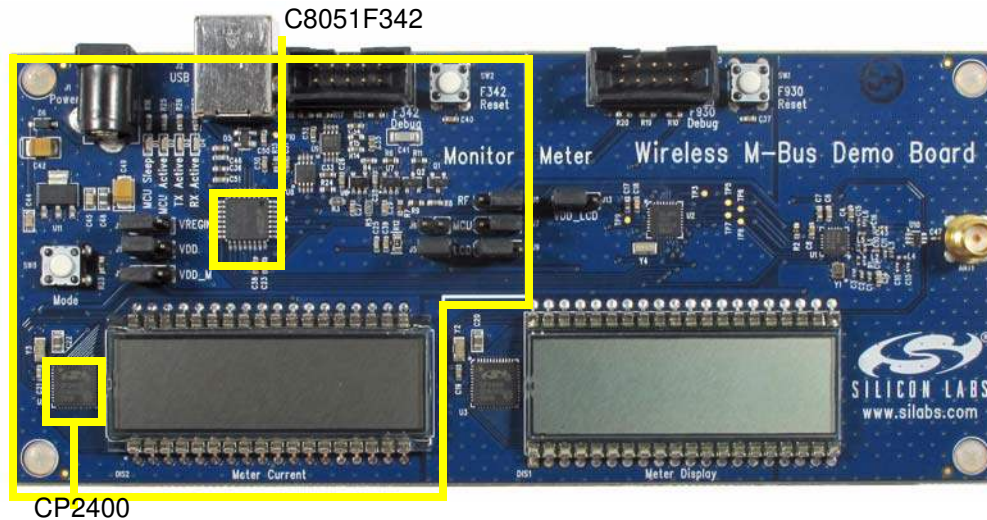

Figure 3. Monitor Section

The monitor section includes the following components:

- C8051F342 USB microcontroller
- CP2400 LCD driver

The C8051F342 microcontroller is used to monitor the meter current consumption, display the current consumption on the eight-digit alphanumeric display, and communicate over USB with the PC applications on the PC host. The discrete current amplifier and integrator are used with the internal comparator and timer to calculate the average current consumption.

A second CP2400 is used to drive the monitor display. The monitor display is an alphanumeric display with eight 14-segment characters. The monitor display is normally used to display average current consumption. Pressing the Mode button will alternately display the elapsed time or output pulse frequency.

Three pin headers are provided for different power options. The Wireless M-Bus demo board may be powered from a USB, a wall adapter, or a 3.6 V long-life Lithium battery. The meter section can be powered from the battery while the monitor section is powered from USB or wall power.

Wireless M-Bus-EK

4. Software Overview

The software system diagram is shown in Figure 4. The meter application firmware runs on the C8051F930 and is written on top of the Wireless M-Bus stack. The meter application firmware measures the temperature or counts the number of pulses and is configured over the UART interface by the monitor application firmware.

The monitor application firmware runs on the C8051F342. The monitor application uses the USBXpress[®] library and embedded API.

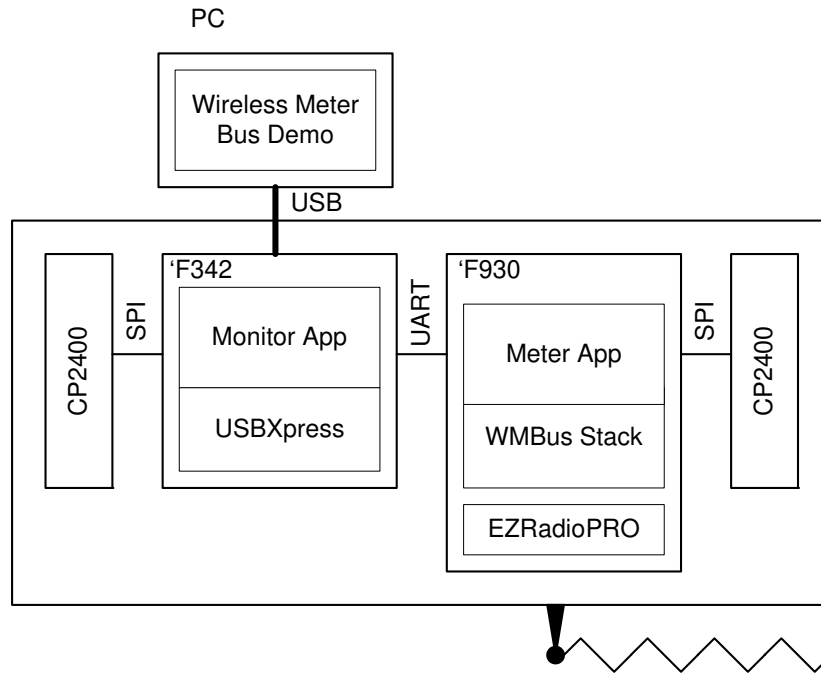

Figure 4. Software System Diagram

5. Install Wireless Meter-Bus Software

Download the Wireless M-Bus demo software from the Silicon Labs web site:

www.silabs.com/wirelessmbus

The Wireless Meter-Bus demo requires Windows 2000®, XP®, Server2003®, Vista®, or Windows 7®. Download the software, unzip it, and run the installer executable.

6. Install USBXpress Driver

The Wireless M-Bus PC software uses the USBXpress API and requires the USBXpress driver. Download and install the USBXpress driver before connecting the Wireless M-Bus board to the computer via USB. There is no cause for concern if you have already connected the Wireless M-Bus demo board to the PC. Disconnect the Wireless M-Bus demo board, and proceed with the USBXpress installation.

Download and install the USBXpress development kit for windows from the Silicon Labs website:

www.silabs.com/USBXpress

Unzip the file and run the executable program. When prompted, check the “Install USBXpress Drivers” checkbox to install the USBXpress Drivers immediately. If you miss this step, the USBXpress driver can be installed later by running the driver installer. The following path is the USBXpress driver installer default location:

C:\SiLabs\MCU\USBXpress\Driver\USBXpressInstaller.exe

Configure the shorting blocks before connecting the USB cable as explained in “7. Hardware Setup”.

Wireless M-Bus-EK

7. Hardware Setup

Please install the USBXpress drivers before connecting the Wireless M-Bus demo board to the PC (see “6. Install USBXpress Driver”).

The Wireless M-Bus Demo Board has three headers on the left side of the board to configure the C8051F342 and C8051F930 power sources.

To configure both MCUs to operate from USB power, configure the headers as shown in Figure 5.

- Configure shorting blocks to short pins 2 and 3 on J10.
- Remove shorting block on J11.
- Configure shorting blocks to short pins 1 and 2 of J12.

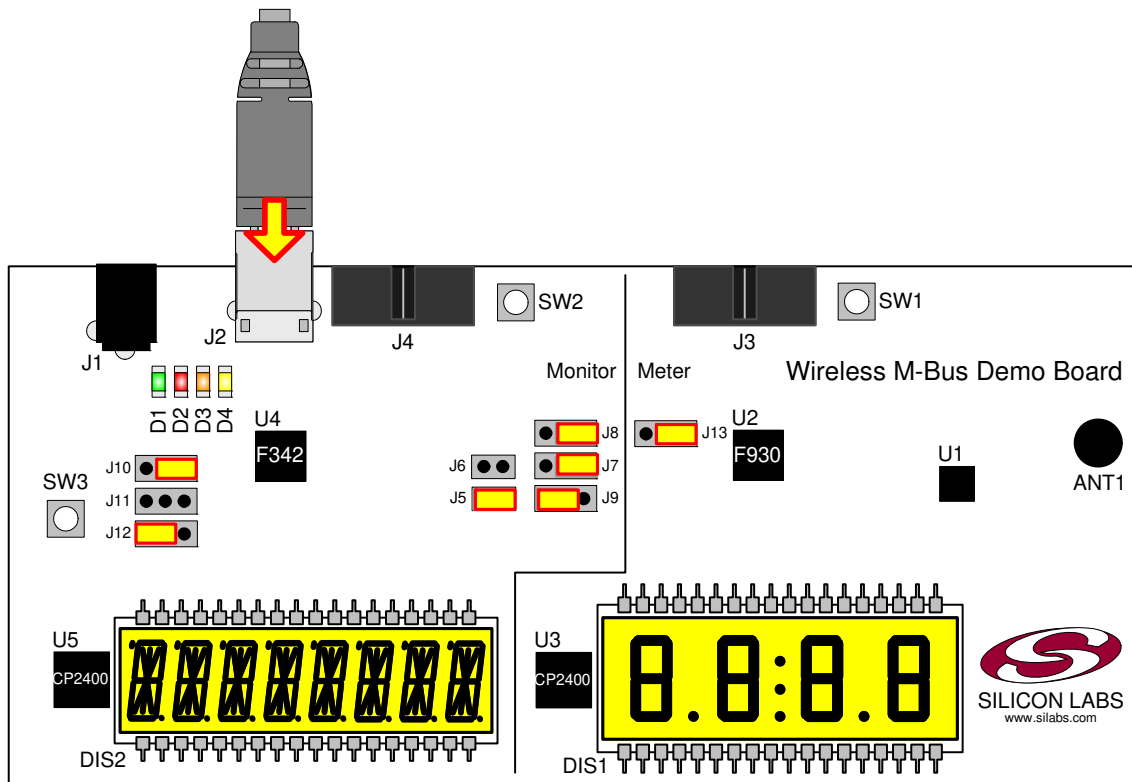

Figure 5. USB Power Configuration

The headers in the middle of the board provide options for measuring the current of the C8051F930 MCU, Si4431 EZRadioPRO, and CP2400 LCD Controller.

To configure the Monitor circuit to include the MCU and radio current, install the headers as shown in Figure 5.

- Short pins 1 and 2 on J5 with a shorting block.
- Remove shorting block on J6 to enable 1 Ω resistor.
- Short pins 2 and 3 on J7 to enable MCU current measurement.
- Short pins 2 and 3 on J8 to enable radio current measurement.
- Short pins 1 and 2 on J9 to disable LCD current measurement.
- Short pins 2 and 3 on J13 to power the CP2400 from the meter supply.

After configuring the headers, connect one end of the USB cable to the Wireless M-Bus demo Board and the other end to the PC. The first time the Wireless M-Bus demo board is connected to the computer, the Found New Hardware wizard will indicate “Found New Hardware - USBXpress Device”. If the Found New Hardware wizard fails to correctly identify the USBXpress device, ensure that the USBXpress drivers are installed correctly as explained in “6. Install USBXpress Driver”.

8. PC Application

After installation, the Wireless M-Bus PC application is located in the following default directory:

C:\SiLabs\MCU\Wireless_Meter_Bus\Software\MBusDemo.exe

The initial screen is shown in Figure 6.

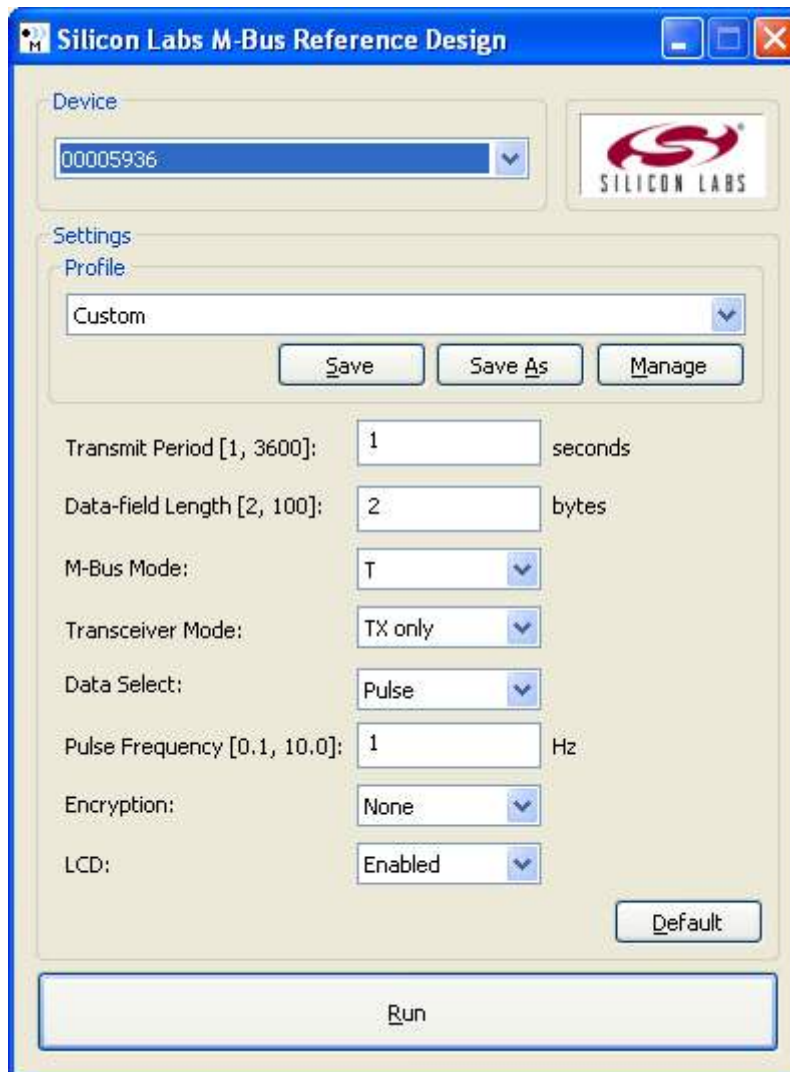

Figure 6. Wireless M-Bus Demo PC Application

If the M-Bus demo hardware is connected to the PC and the USBXpress driver has been installed, the demo board serial number should be displayed in the Device drop-down menu. If the serial number is not displayed, perform the following steps:

1. Check that the USBXpress driver has been installed.
2. Check that the shorting block configuration is set up according to the hardware setup.
3. Check the USB connection to your PC.
4. Check that the LCD displays are active.

If the LCD displays are not active, this indicates that the board is not powered.

Wireless M-Bus-EK

The power consumption of the meter depends on the parameter settings. The PC application allows the following parameters to be set:

- Transmit Period
- Data Field Length
- M-Bus Mode
- Transceiver Mode
- Data Select
- Pulse Frequency
- Encryption
- LCD Enabled

8.1. Transmit Period

The transmit period can be set for 1 second to 3600 seconds (5 minutes). The C8051F930 MCU will sleep for this period with the Si4431 EZRadioPRO in shut-down. Then, it will wake up, take a measurement, and send the data. The Transmit period has a large effect on the power consumption. A long transmit period is necessary to achieve multi-year battery life.

8.2. Data Field Length

The data field length sets the length of the application payload in the M-Bus packet. The minimum length is 2, including the required CI byte. The maximum is 100 bytes. If AES encryption is enabled, this field must be a multiple of 16.

8.3. M-Bus Mode

The following menus can be used to select the M-Bus mode:

- Mode S: 32,768 cps Manchester encoding
- Mode SL: same as above with a very long preamble
- Mode T: 100 kcps, three-out-of-six encoding
- Mode R: 4800 cps, Manchester encoding

Mode T provides the highest data rate and gives the lowest power consumption. The current consumption of Mode SL with the long preamble is slightly higher than Mode S. The long preamble is not necessary for the Si4431 EZRadioPRO. Power consumption is the highest using Mode R. Sending a long packet using Mode R may take hundreds of milliseconds. Mode T2, Mode S2, and Mode R2 may be selected by choosing TX and RX in the Transceiver mode menu. According to the specification, Mode R should always use TX and RX. For additional information about M-Bus modes, refer to “AN451: Wireless M-Bus Software Implementation” and EN 13757-4.

8.4. Transceiver Mode

The Wireless M-Bus demo PC application provides two transceiver modes:

- TX
- TX and RX

If the TX only mode is selected, the meter will sleep for the transmit period, wake up, and transmit its data. If the TX and RX mode is selected, the meter will wake up and send an access demand message. If the access demand message is acknowledged, the meter will send its data to the other device.

When a meter reader (Other) device is present, the current consumption of the two-way communication is highest. Because there is overhead associated with the two-way data transfer. If the meter reader (Other) is not present, the two-way meter only needs to send the access demand message and wait for the response time. Still, the response time is long compared to the message length; so, the one-way communication usually provides the lowest power consumption.

8.5. Data Select

The options for the Data Select menu are:

- Pulse
- Temperature
- None

The selected data is displayed on the LCD and transmitted in the data payload.

The Pulse option provides a pulse counter. The C8051F342 acts as a virtual water or gas meter. The C8051F930 will wake up on each rising and falling edge and count the number of pulses. The pulse rate is programmable.

The Temperature sensor uses the onboard temperature sensor on the C8051F930.

The power consumption will be higher using the pulse counter. This is because the MCU must wake up often to count the number of pulses. Using the temperature sensor, the current consumption is less because the temperature is only measured before each transmission.

8.6. Pulse Frequency

When pulse data is selected, the pulse frequency is programmable from 0.1 to 10 Hz. The 0.1 Hz provides one pulse every ten seconds.

8.7. Encryption

The AES encryption option will encrypt the data before sending. The demo uses the AES 128 block cipher.

Encrypting the data takes some extra time and results in higher power consumption. The encryption time will be higher for longer data lengths.

Since the demo uses the basic AES128 block cypher, the data size must be a multiple of 16. The transmission data should be padded with zeros. Other encryption modes might accommodate an arbitrary length.

8.8. LCD enabled

The LCD display takes power to operate and update. The three-pin header, J9, may be configured to exclude the LCD current from the measurement. However, the C8051F930 is still updating the LCD display. Disabling the LCD turns off the Meter display, and the MCU will not have to update the display. This decreases the time that the C8051F930 has to be awake and lowers power consumption.

Normally, the CP2400 is powered from the same voltage supply as the C8051F930. However, the LCD current is so low that the CP2400 may be powered from an I/O pin of the C8051F930. The LCD current may be further decreased by configuring J13 with a shorting block on Pins 1 and 2. This powers the CP2400 from an C8051F930 I/O pin and further lowers the power consumption when the LCD is disabled.

Wireless M-Bus-EK

9. Wireless M-Bus Stack

The source code for the Wireless M-Bus stack is available as a separate download from the M-Bus web page: www.silabs.com/wirelessmbus

Additional information on the Wireless M-Bus stack may be found in the following application notes:

“AN451: Wireless M-Bus Software Implementation”

“AN452: Wireless M-Bus Stack Programmers Guide”

The source code may only be used in accordance with the terms in the click-through license agreement. The source may only be used with a Silicon Labs MCU and Silicon Labs radio product.

The Wireless M-Bus source code supports two development platforms: The Si4431 EzRadioPRO development platform using the C8051F930 MCU and the Si1000 integrated MCU/EZRadioPRO platform.

The M-Bus demo board is intended as a demo only. It is not supported as a development platform.

10. Si4431 Wireless M-Bus Development Platform

The Si4431 Wireless M-Bus Development Platform requires the purchase of the following items:

- Three SDBC-DK3 EZRadioPRO Wireless Development Kits
- Three 4431-DKDB3 - Si4431 +13 dB High-Band Test Cards
- Two EC3 -USB Debug Adapters
- One Supported Unlimited Compiler (Keil, Raisonance, or SDCC)

The Basic setup is shown in Figure 7.

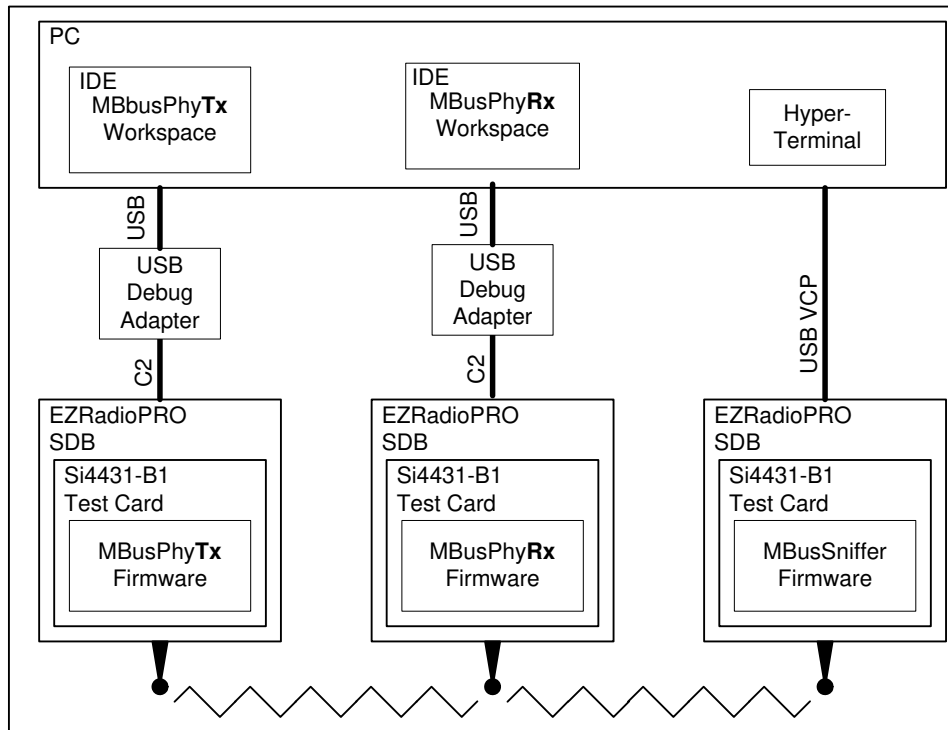

Figure 7. Si4431 Wireless M-Bus Development Platform

The SDBC-DK3 EZRadioPRO Wireless Development Kit includes test cards for the +20 dB Si4432. These can be used for M-Bus development, but the power will be too high. Note that the M-Bus stack requires the B1 revision of the Si4431/2; so, an older version of the Si4432 cannot be used.

The first Software Development Board (SDB) functions as the transmitter or “Meter” device. The second SDB functions as a receiver or “Other” device. The third SDB is used for an optional sniffer. The sniffer board is not absolutely necessary but is very useful for debugging.

The Wireless M-Bus stack requires that the shut-down (SDN) pin of the radio must be connected to P0.7 on the MCU; so, some small modification of the SDB is required. Cut the trace on Shorting Jumper SJ11 between Pins 2 and 3. Short Pins 1 and 2 using a 0 Ω 805 resistor, wire, or solder bridge.

The hardware_defs.h file (included in the Wireless M-Bus stack source code) provides a hardware abstraction layer for the M-Bus stack. The hardware_defs.h file should be edited to select the desired hardware platform before using. Define the Si4431 software development board and comment out the other hardware options.

Wireless M-Bus-EK

11. Si1002 Wireless M-Bus Development Platform

The Si1002 Wireless M-Bus Development Platform requires the purchase of the following items:

- Three Si1000 Development Kits
- Three Si1002 Daughter Cards
- One Supported Unlimited Compiler (Keil, Raisonance, or SDCC)

The Basic setup is shown in Figure 8.

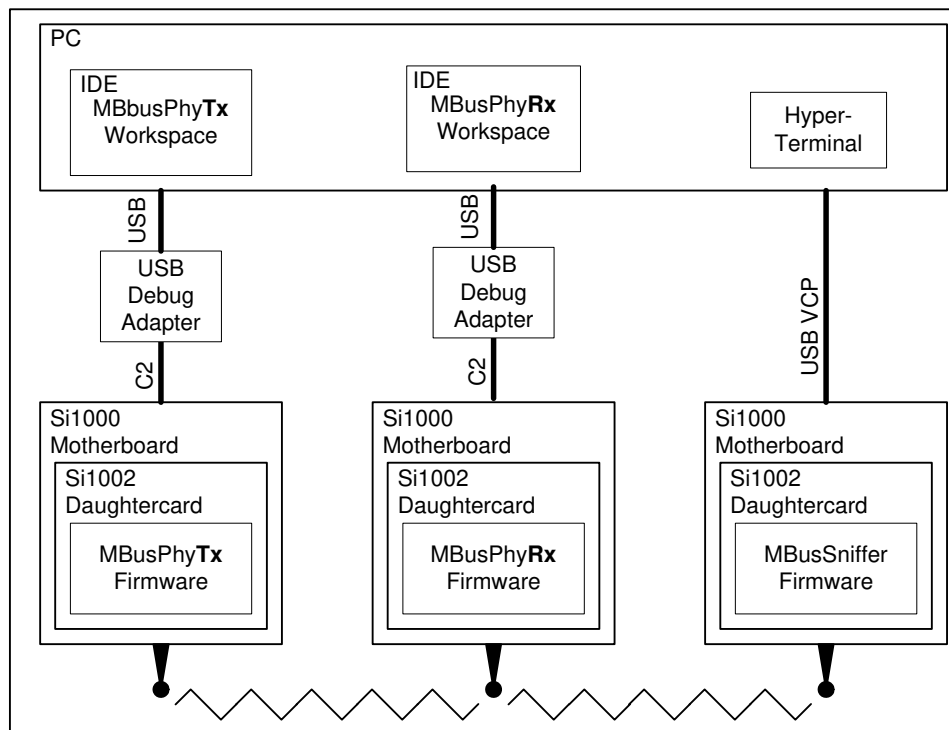

Figure 8. Si1002 Wireless M-Bus Development Platform

The Si1000 Development Kit includes test cards for the +20 dB Si1000. These can be used for M-Bus development, but the power will be too high. Note that the M-Bus stack requires the C revision of the Si1000/2.

The first Si1002 daughter card functions as the transmitter or “Meter” device. The second Si1002 daughter card functions as a receiver or “Other” device. The third daughter card is used for an optional sniffer. The sniffer board is not absolutely necessary but is very useful for debugging.

The Si1002 daughter card is configured with SDN connected to P2.6 and nIRQ connected to P0.1. No hardware modifications are necessary. The factory jumper settings for the MCU motherboard are suitable for M-Bus stack development.

The hardware_defs.h file provides a hardware abstraction layer for the M-Bus stack. The hardware_defs.h should be edited to select the desired hardware platform before use. Define the Si1002 MCU mother board and comment out the other hardware options.

12. Additional Information

For additional information on the Wireless M-Bus stack, refer to the following application notes:

“AN451: Wireless M-Bus Software Implementation”

“AN452: Wireless M-Bus Stack Programmers Guide”

Additional Information can be found in the following product datasheets

C8051F930—Low-Power MCU

C8051F340—USB MCU

CP2400—LCD controller

Si4430/1/2/3—EZRadioPRO wireless Transceiver

Si1000—Low-Power MCU with Si4431 EZRadioPRO Transceiver

A detailed description of the Si4431 EZRadioPRO registers can be found in the following application note:

“AN440: Si4430/31/32 Register Descriptions”

Detailed RF analysis and measurements of the M-Bus physical layer on the EZRadioPRO can be found in the following application note:

“AN361: Wireless M-Bus Implementation using EZRadioPRO® Devices”

For technical support, use the online support web page. For support on the M-Bus demo kit, M-Bus stack, or Si1000, select an MCU product. For support on the Si4430/1/2 or RF performance questions, select a wireless product.

<http://www.silabs.com/support/>

Wireless M-Bus-EK

13. Header Descriptions

Headers J10 and J11 may be configured to select the Monitor section power source.

Table 1. Monitor Section Power Options

Monitor Section Power Source	J10	J11
USB Bus Power	Short 2-3	Remove Shorting Block
AC to DC Power Adapter	Short 1-2	Short 1-2
3.6 V Lithium Battery	Short 1-2	Short 2-3

Header J12 may be used to select the power source for the Meter Section.

Table 2. Meter Section Power Options

Meter Section Power Source	J12
USB Bus Power	Short 1-2
AC to DC Adapter	Short 1-2
3.6 V Lithium Battery	Short 2-3

Header J5 may be used to select the power source for the Meter LCD. This includes the CP2400 Meter LCD controller (U3). Normally the LCD will be powered from the same source as the Meter section, as selected above. Alternatively, the LCD may be powered from an MCU port pin. This provides a lower current consumption when the LCD is inactive.

Table 3. Meter LCD Power Options

Meter LCD Power Source	J5
Meter Section Power Source	Short 2-3
C8051F930 Port Pin P0.0	Short 1-2

Headers J7-9 may be used to select which components in the Meter section are included in the current measurement.

Table 4. Current Measurement Options

Header	Component	Enabled	Disabled
J7	C8051F930 MCU	Short 1-2	Short 2-3
J8	Si4431 EZRadioPRO	Short 1-2	Short 2-3
J8	CP2400 LCD Controller	Short 1-2	Short 2-3

Header J5 and Header J6 are provided to permit the usage of an external current meter. Normally, a shorting block is installed on J5 and J6 is not populated with a shorting block. To use an external meter, install a shorting block on J6; remove the shorting block on J5, and connect a current meter between pins 1 and 2 of J5.

Table 5. External Meter Options

Set-Up	J5	J6
On-board Current Measurement	Install Shorting Block	Remove Shorting Block
External Current Measurement	Remove Shorting Block and Connect Meter	Install Shorting Block

Wireless M-Bus-EK

14. Schematics

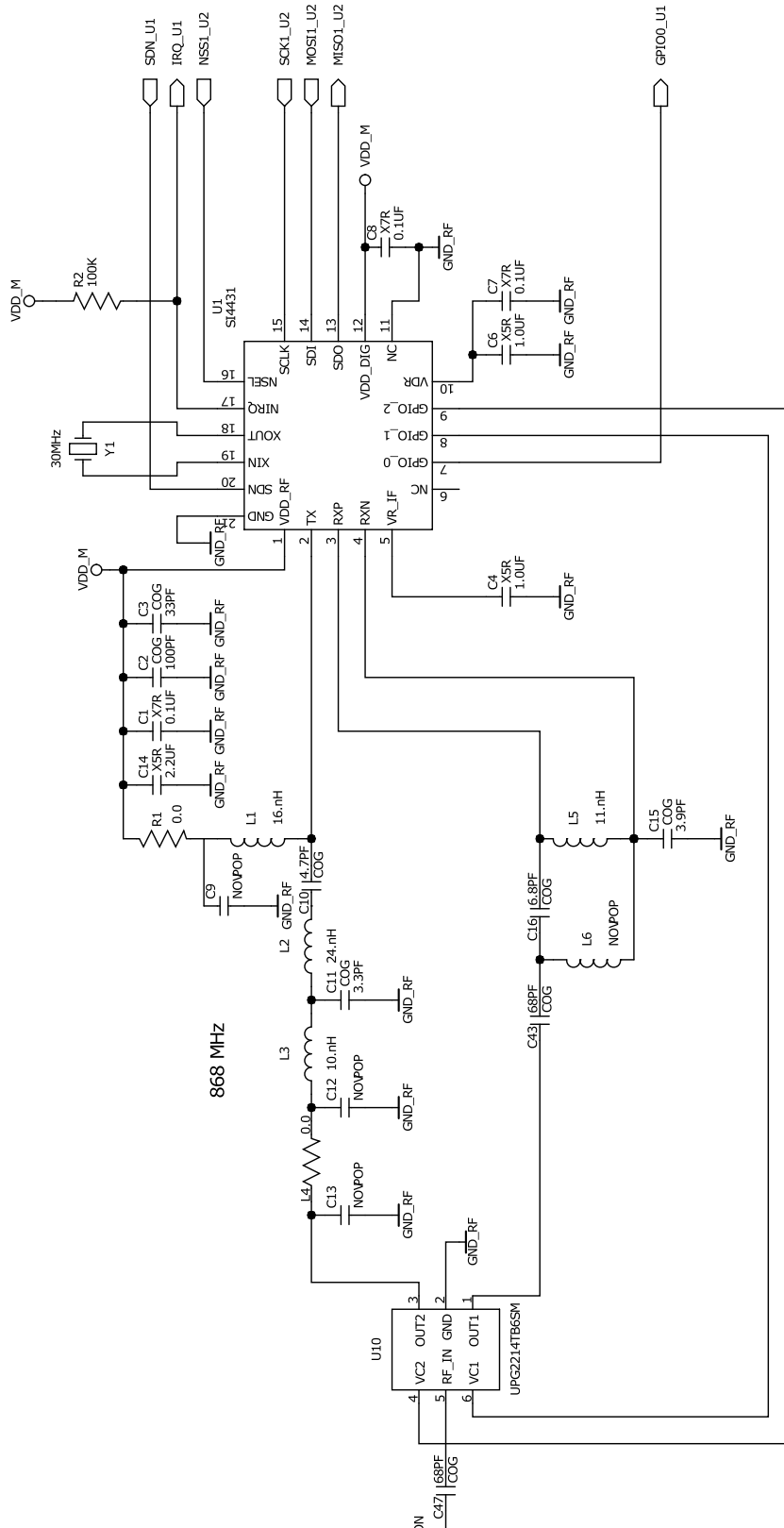
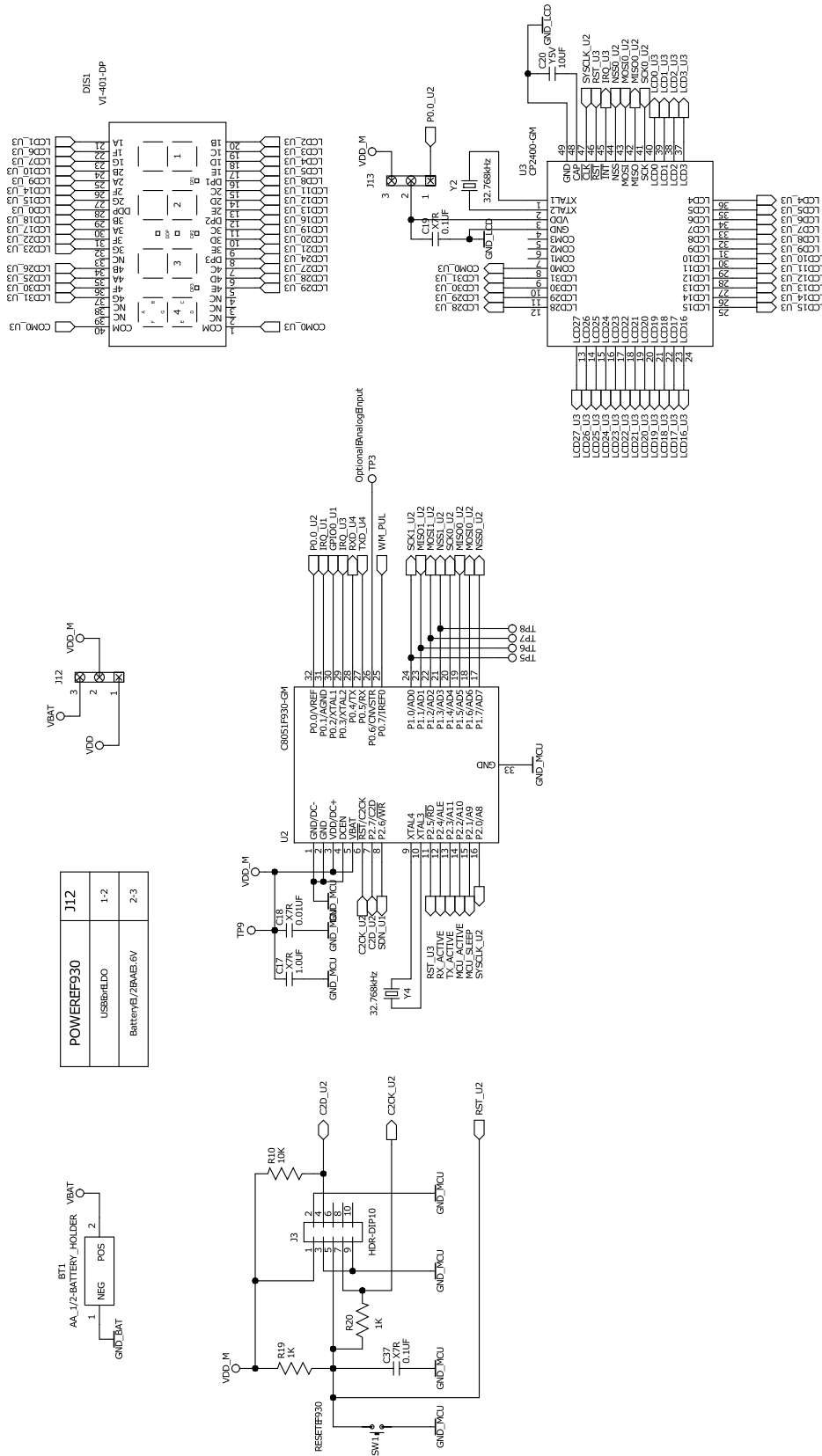

Figure 9. M-Bus Demo Board RF Section (1 of 4)



POWEREF930	J12
USBtoLDO	1-2
BatteryV1/2PAB6V	2-3

Figure 10. M-Bus Demo Board Meter Section (2 of 4)

Wireless M-Bus-EK

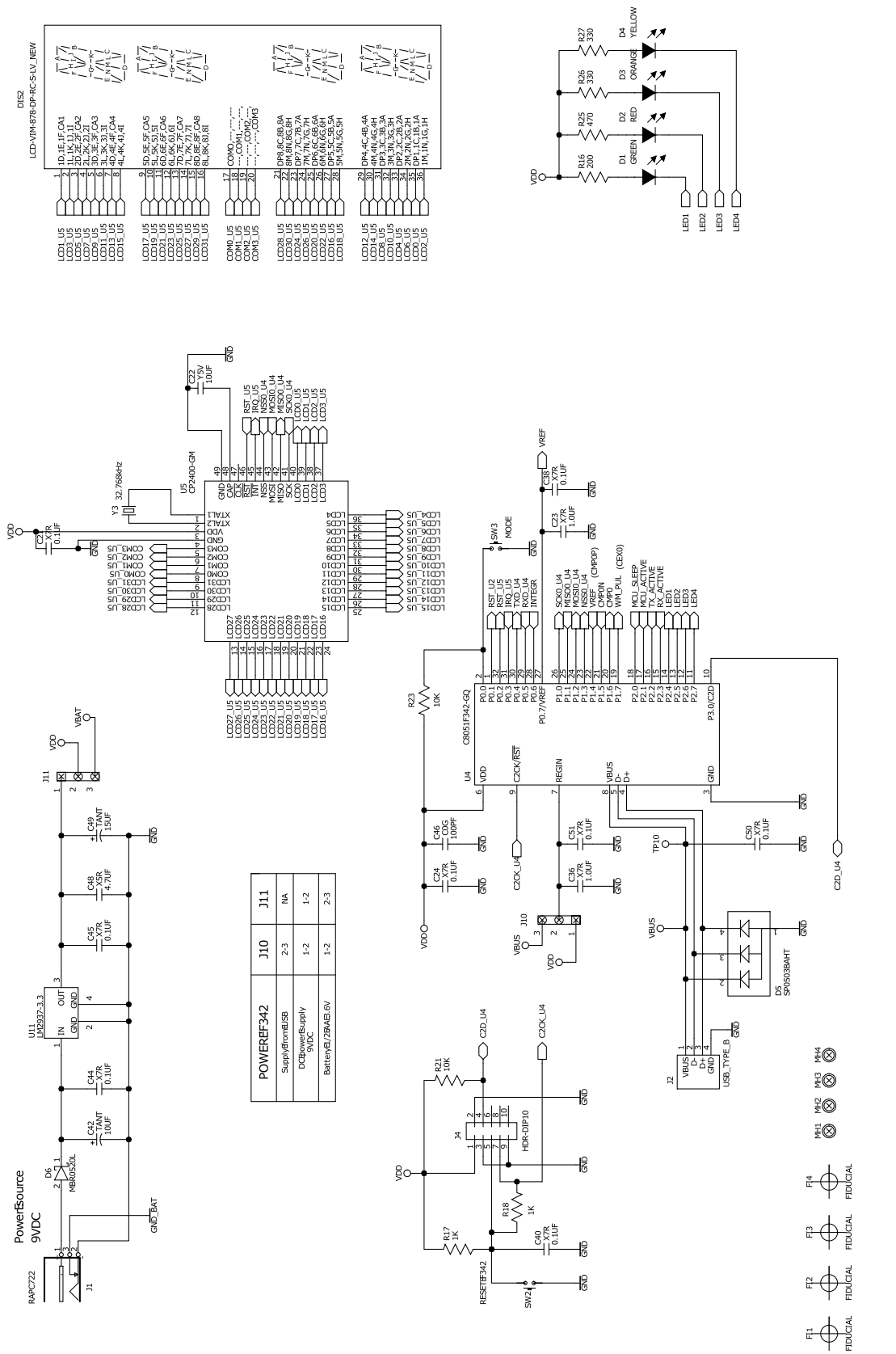

Figure 11. M-Bus Demo Board USB Section (3 of 4)

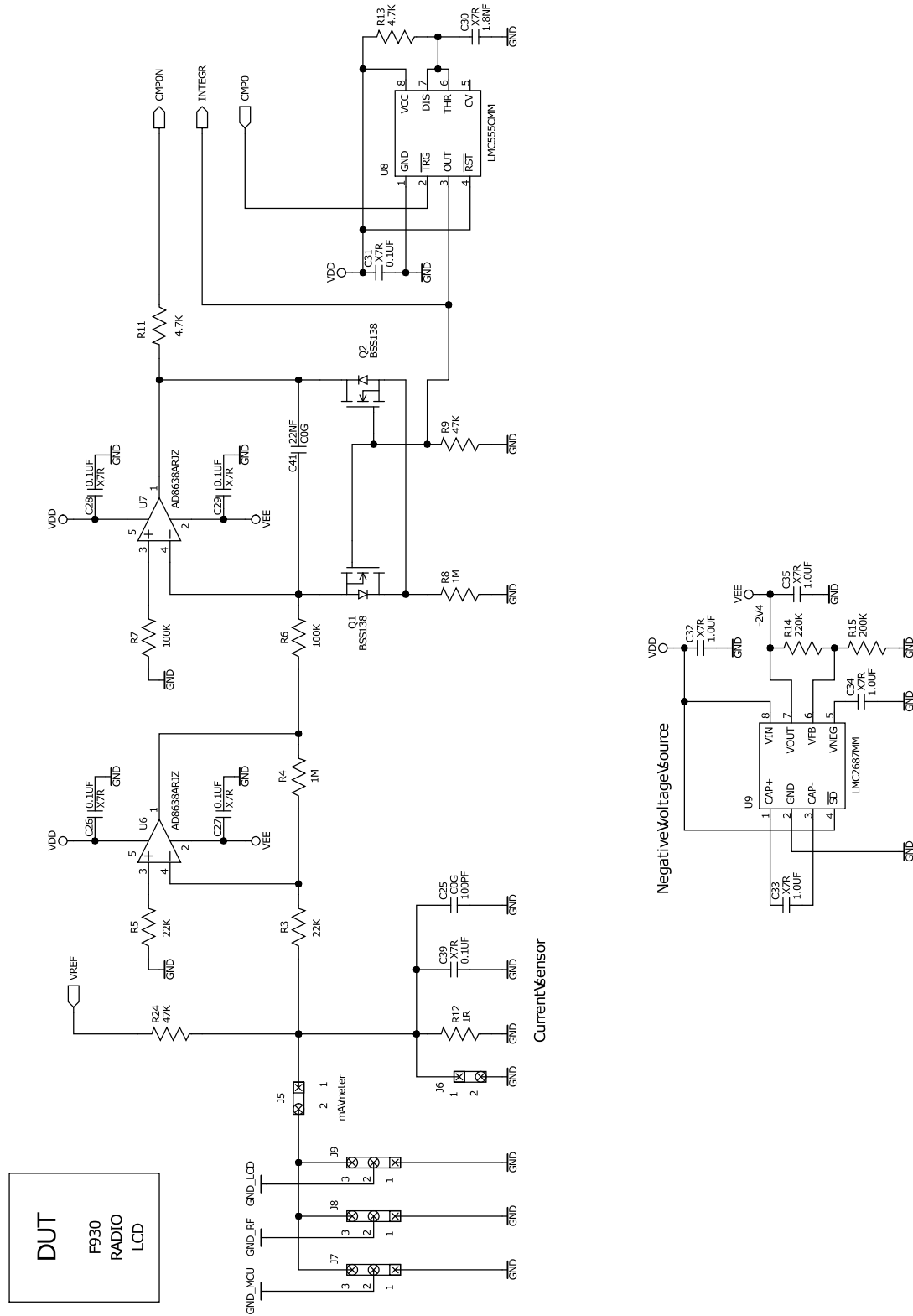

Figure 12. M-Bus Demo Board Current Measurement Section (4 of 4)

Wireless M-Bus-EK

CONTACT INFORMATION

Silicon Laboratories Inc.

400 West Cesar Chavez
Austin, TX 78701
Tel: 1+(512) 416-8500
Fax: 1+(512) 416-9669
Toll Free: 1+(877) 444-3032

Please visit the Silicon Labs Technical Support web page:
<https://www.silabs.com/support/pages/contacttechnicalsupport.aspx>
and register to submit a technical support request.

The information in this document is believed to be accurate in all respects at the time of publication but is subject to change without notice. Silicon Laboratories assumes no responsibility for errors and omissions, and disclaims responsibility for any consequences resulting from the use of information included herein. Additionally, Silicon Laboratories assumes no responsibility for the functioning of undescribed features or parameters. Silicon Laboratories reserves the right to make changes without further notice. Silicon Laboratories makes no warranty, representation or guarantee regarding the suitability of its products for any particular purpose, nor does Silicon Laboratories assume any liability arising out of the application or use of any product or circuit, and specifically disclaims any and all liability, including without limitation consequential or incidental damages. Silicon Laboratories products are not designed, intended, or authorized for use in applications intended to support or sustain life, or for any other application in which the failure of the Silicon Laboratories product could create a situation where personal injury or death may occur. Should Buyer purchase or use Silicon Laboratories products for any such unintended or unauthorized application, Buyer shall indemnify and hold Silicon Laboratories harmless against all claims and damages.

Silicon Laboratories and Silicon Labs are trademarks of Silicon Laboratories Inc.

Other products or brandnames mentioned herein are trademarks or registered trademarks of their respective holder