

DESCRIPTION

The PGS1000 series of hydrogen sensors detects hydrogen concentration in air by measuring the change in thermal conductivity of the gas mixture. Hydrogen and air have very different thermal conductivity. Variation in hydrogen concentration results in significant changes in the thermal conductivity of the gas mixture.

The PGS1000 series uses Posifa's second-generation thermal conductivity die, packaged in an SMD form factor. It uses two thermal conductivity dies in a differential configuration: one sealed in dry air and acting as a reference; the other exposed to the gas mixture. Such a design achieves an excellent signal-to-noise ratio due to common-mode noise rejection and maximization of signal amplification. In addition, the sensor is excited with a pulsed waveform (400ms on and 1000ms off), resulting in a heater temperature that is almost the same as the ambient. This feature lends intrinsic safety to the sensor.

Like any hydrogen sensors based on thermal conductivity, Posifa devices are subject to specific cross sensitivity with other gases whose thermal conductivity is also significantly different from that of air, such as humidity and hydrocarbon gases (e.g. methane). Therefore Posifa's hydrogen sensors perform optimally in applications where interfering gases are absent, or their cross sensitivity is within the acceptable margin of error required by the application.

When deployed in a suitable environment, Posifa's MEMS thermal conductivity hydrogen sensors are superior to competing technologies. The low-cost devices offer fast response times and long-term stability.



FEATURES

- Broadest available ranges, up to 100 % volume
- Fast response time < 1.4 s
- Temperature compensation
- Pulsed excitation minimizes heater temperature for safe operation
- Long-term stability

APPLICATIONS

- Hydrogen leak detection
- Process monitoring

ABSOLUTE MAXIMUM RATINGS

- Operating temperature: -40 °C to 85 °C
- Storage temperature: -40 °C to 90 °C
- Shock: 100 g peak (5 drops, 3 axis)

ELECTRICAL CHARACTERISTICS

Test Conditions: Vdd = 5 Vdc, Ta=21 °C, RH = 5%

SPECIFICATIONS	MIN	TYP	MAX	UNIT	CONDITIONS
Detection Gas	Hydrogen in air				
Principle of Detection	Thermal conductivity				
Range (PGS1004)	0 - 4			Vol %	
Output	0		40000	Count	I ² C communication
Resolution (PGS1004)		1		ppm	
Accuracy		6		% reading	
Repeatability		0.05		% F.S.	
Long-Term Stability		0.1		% F.S. / year	
Response Time			1.4		
Start-Up Time		0.5			
Operating Temperature	-40		85	°C	
Storage Temperature	-40		90	°C	
Supply Voltage Vdd	4.75	5	5.25	V	
I ² C Pullup Voltage		Vdd or 3.3		V	
Current Consumption		8		mA	Average
Cross Sensitivity to Humidity		60		ppm / % RH	at 21 °C
Corss Sensitivity to CH ₄		13		%	
Dimensions		23 x 20 x 10		mm	

OUTPUT DESCRIPTION

Hydrogen concentration in ppm = output count

For example, when the output count = 15000, the hydrogen concentration is 15000 ppm (or 1.5 % vol).

PACKAGE DIMENSIONS

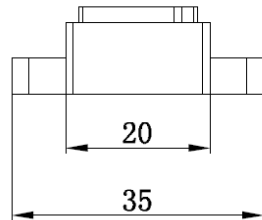
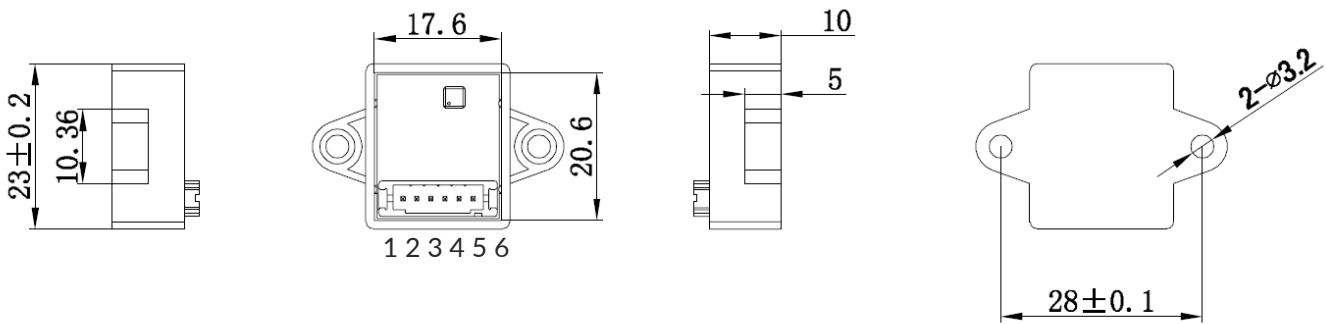

PIN	Description
1	N/C
2	N/C
3	SCL
4	SDA
5	GND
6	VDD

Unit: mm

Note
Mating connector is JST PAP-06V-S.

ORDERING INFORMATION

PART NUMBER	SPECIFICATIONS
PGS1004	0 to 4 % vol, I2C output