

REVISIONS					
REV	DATE	DESCRIPTION	BY	CHK	APP'D
B3	03AUG2022	REVISED PER ECR-21-117154	SKR	VS	

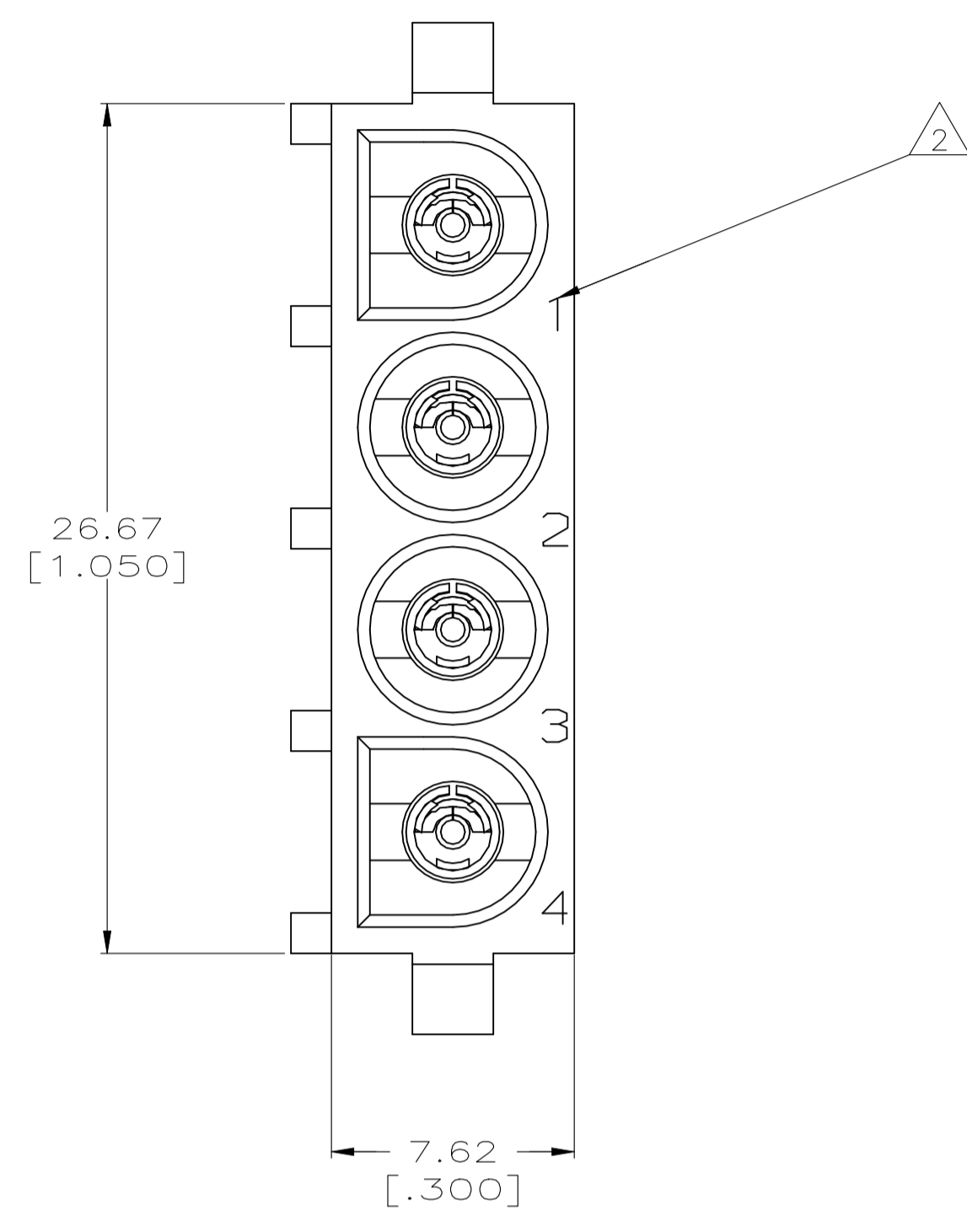

- 1 PARTS COMPLY TO AMP SOLDERABILITY SPECIFICATION 109-11-3.
- 2 CIRCUIT IDENTIFICATION CHARACTERS ARE ADJACENT TO THE INDICATED CAVITIES, BUT LOCATION AND ORIENTATION MAY DIFFER FROM PRINT.
- 3 DIMENSIONS IN BRACKETS ARE IN INCHES.
- 4 CONTACT IS STAMPED FROM PRE-PLATED STOCK WHICH IS PLATED OVERALL WITH 0.00127 - 0.00178 [.000050 - .000070] NICKEL, THEN STRIPED WITH 0.00076 [.000030] GOLD IN CONTACT AREA INDICATED AND MATTE TIN LEAD ON SOLDER TAIL END.
- 5 DRAIN HOLES LOCATED AS SHOWN. OPTIONAL CONSTRUCTION- ALL DRAIN HOLES LOCATED 90° AS SHOWN IN DETAIL A.
- 6 CONTACT IS STAMPED FROM PRE-PLATED STOCK WHICH IS PLATED OVERALL WITH 0.00127 - 0.00178 [.000050 - .000070] NICKEL, THEN STRIPED WITH 0.00076 [.000030] GOLD IN CONTACT AREA INDICATED AND MATTE TIN ON SOLDER TAIL END.
- 7 SUPERSEDED BY 794783-3
- 8. DIMENSION SHOWN REPRESENT PRODUCT IN DRY CONDITION. ADDITIONAL 2% GROWTH DUE TO END USE LOCATION MOISTURE ABSORPTION MAY OCCUR AND SHOULD BE ACCOUNTED FOR.

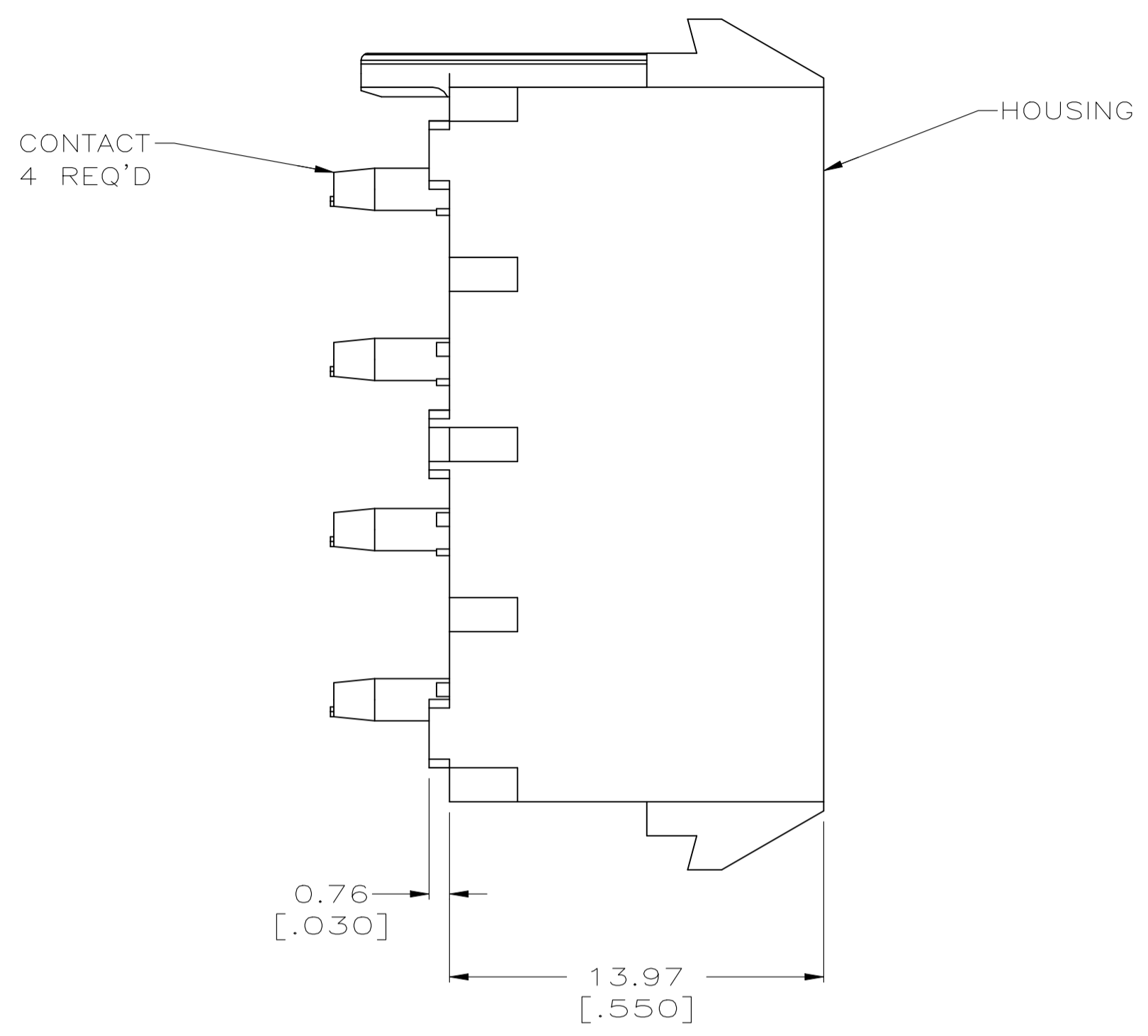
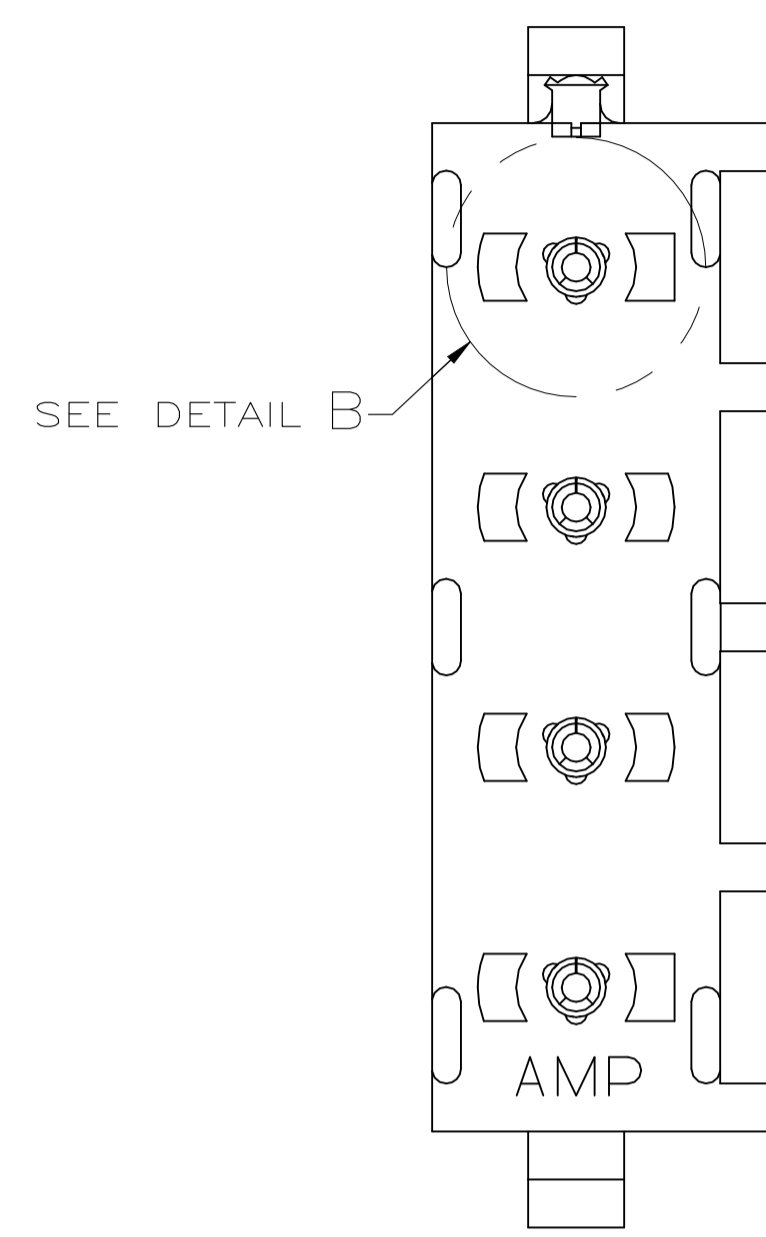
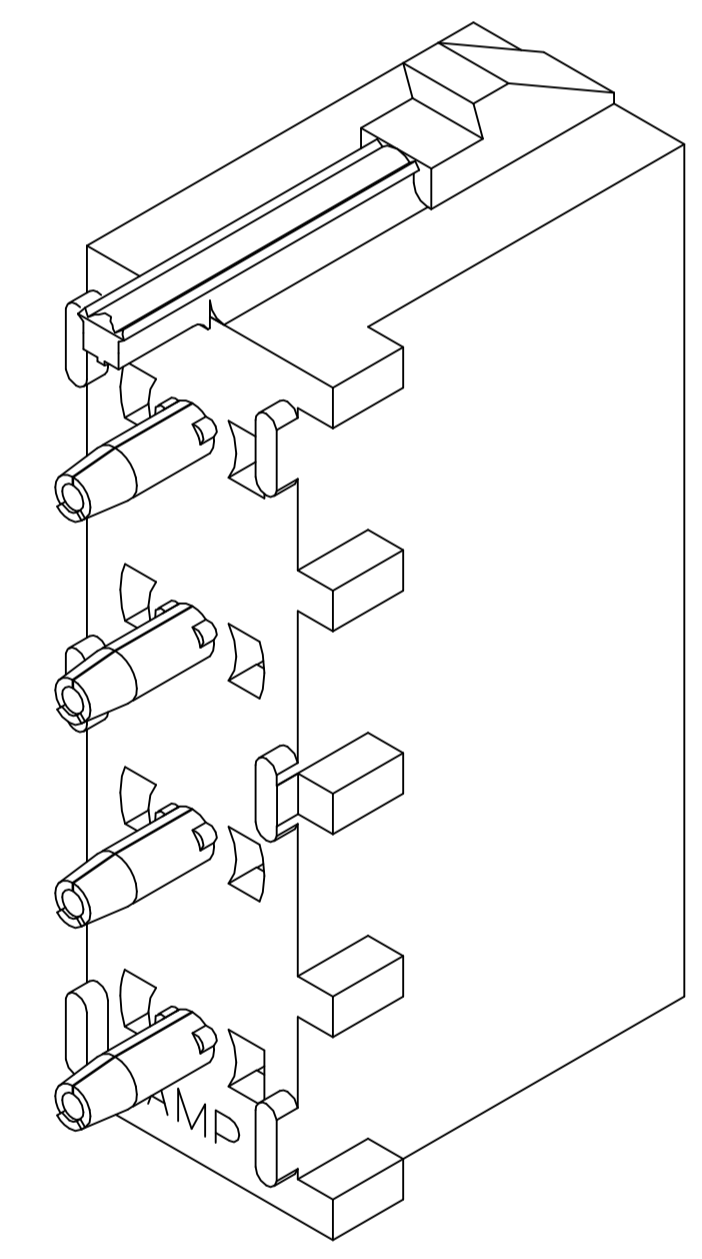

3-DIMENSIONAL MODEL NTS

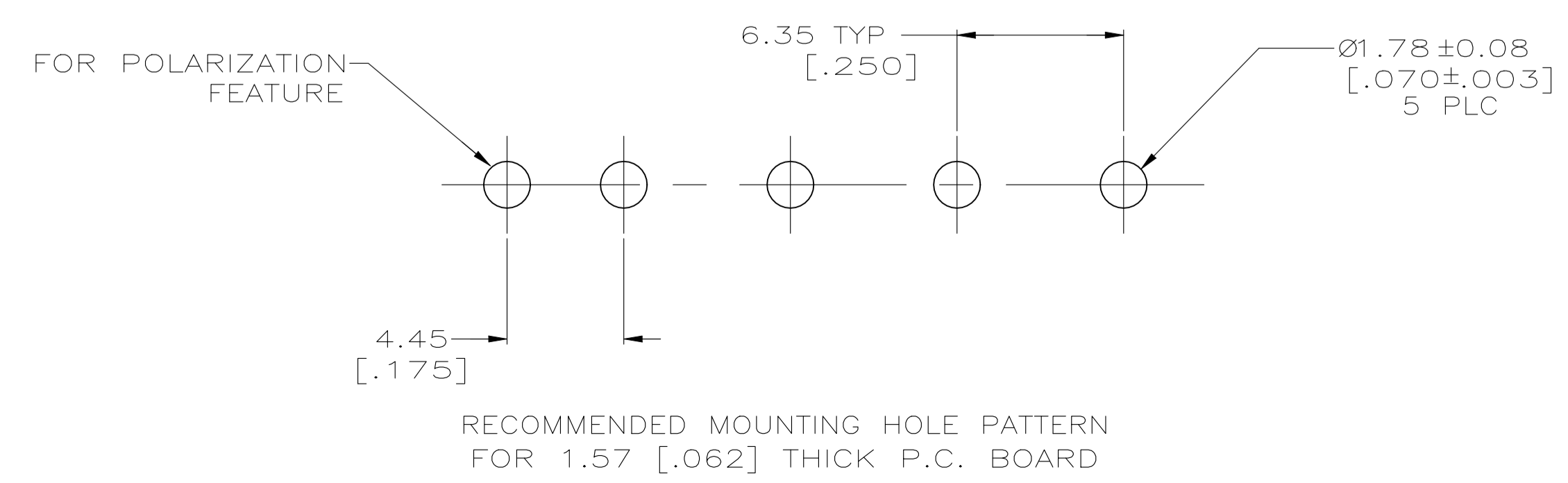
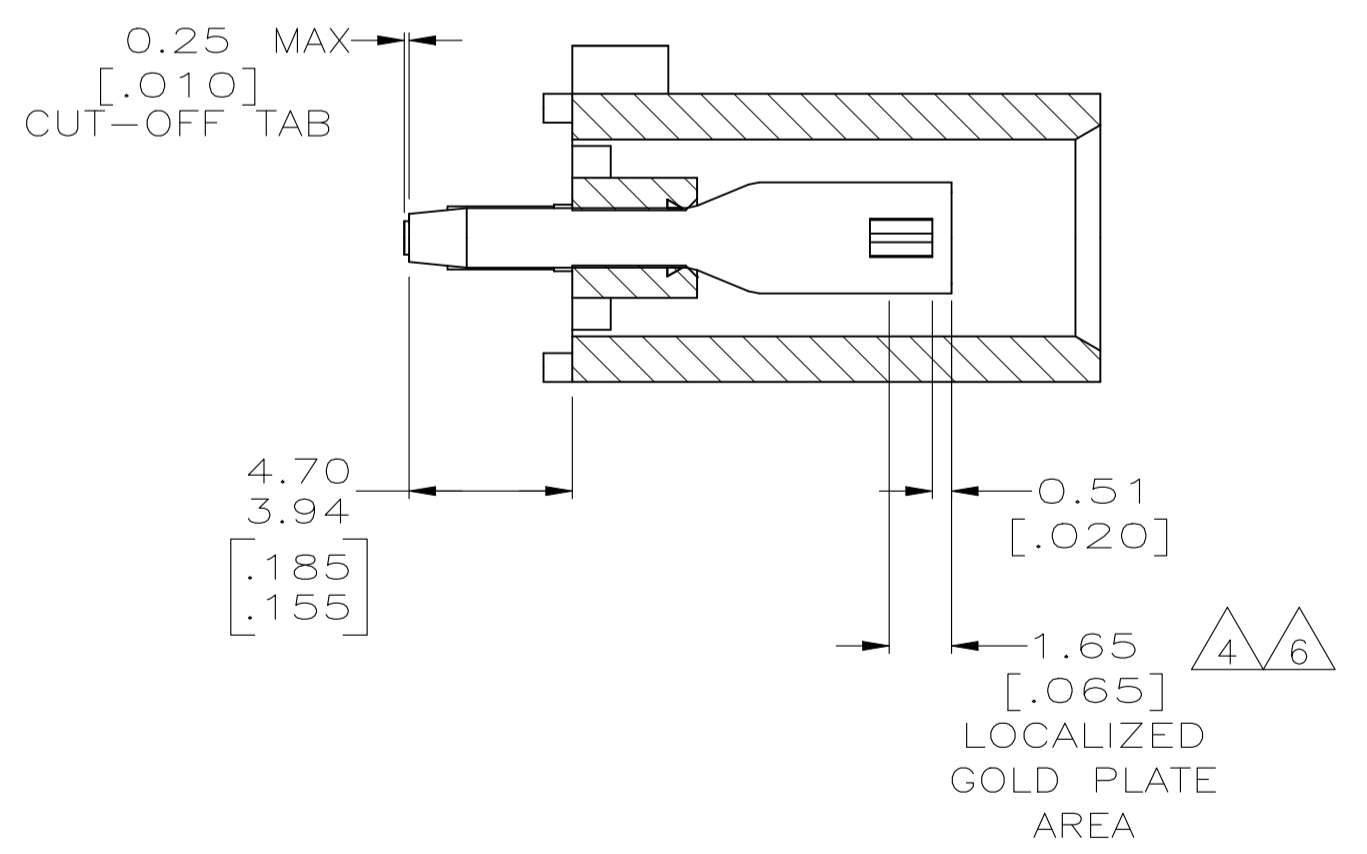
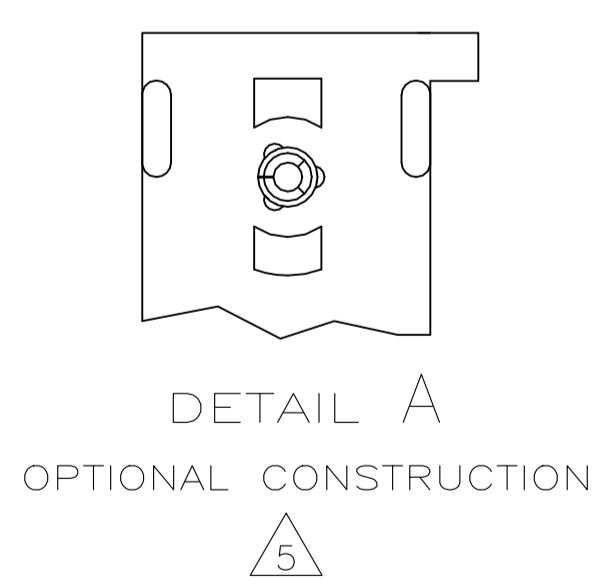

PHOSPHOR BRONZE, GOLD	NYLON,UL94V-0,BLACK	794783-3
PHOSPHOR BRONZE, GOLD	NYLON,UL94V-0,BLACK	794783-2
PHOSPHOR BRONZE, PRE-TIN	NYLON,UL94V-0,BLACK	794783-1
CONTACT MATERIAL AND FINISH	HOUSING MATERIAL	PART NUMBER

THIS DRAWING IS A CONTROLLED DOCUMENT.		DIN L McEACHIN 19-JUN-2000	TE Connectivity
DIMENSIONS: mm [INCHES]		CHK K COBLE 19-JUN-2000	
TOLERANCES UNLESS OTHERWISE SPECIFIED:		APP'D K COBLE 19-JUN-2000	NAME
0 PLC ± -		PRODUCT SPEC	SOCKET HEADER ASSEMBLY, POLARIZED, 4 CIRCUIT UNIVERSAL MATE-N-LOK™
1 PLC ± -		APPLICATION SPEC	
2 PLC ± 0.13 [.005]		SIZE	A1
3 PLC ± -		WEIGHT	0.000000
4 PLC ± -		CAGE CODE	00779
ANGLES ± 0°30'		DRAWING NO	794783
MATERIAL SEE TABLE		FINISH SEE TABLE	RESTRICTED TO
		CUSTOMER DRAWING	SCALE 5:1 SHEET 1 of 1 REV B3