



**High-Performance 8-Bit Microcontrollers**

**Z8 Encore! XP<sup>®</sup> F082A  
Series**

**Product Specification**

PS022825-0908



**Warning:** DO NOT USE IN LIFE SUPPORT

### **LIFE SUPPORT POLICY**

ZILOG'S PRODUCTS ARE NOT AUTHORIZED FOR USE AS CRITICAL COMPONENTS IN LIFE SUPPORT DEVICES OR SYSTEMS WITHOUT THE EXPRESS PRIOR WRITTEN APPROVAL OF THE PRESIDENT AND GENERAL COUNSEL OF ZILOG CORPORATION.

### **As used herein**

Life support devices or systems are devices which (a) are intended for surgical implant into the body, or (b) support or sustain life and whose failure to perform when properly used in accordance with instructions for use provided in the labeling can be reasonably expected to result in a significant injury to the user. A critical component is any component in a life support device or system whose failure to perform can be reasonably expected to cause the failure of the life support device or system or to affect its safety or effectiveness.

### **Document Disclaimer**

©2008 by Zilog, Inc. All rights reserved. Information in this publication concerning the devices, applications, or technology described is intended to suggest possible uses and may be superseded. ZILOG, INC. DOES NOT ASSUME LIABILITY FOR OR PROVIDE A REPRESENTATION OF ACCURACY OF THE INFORMATION, DEVICES, OR TECHNOLOGY DESCRIBED IN THIS DOCUMENT. ZILOG ALSO DOES NOT ASSUME LIABILITY FOR INTELLECTUAL PROPERTY INFRINGEMENT RELATED IN ANY MANNER TO USE OF INFORMATION, DEVICES, OR TECHNOLOGY DESCRIBED HEREIN OR OTHERWISE. The information contained within this document has been verified according to the general principles of electrical and mechanical engineering.

Z8, Z8 Encore!, and Z8 Encore! XP are registered trademarks of Zilog, Inc. All other product or service names are the property of their respective owners.



**ISO 9001:2000  
FS 507510**

Zilog products are designed and manufactured under an ISO registered 9001:2000 Quality Management System. For more details, please visit [www.zilog.com/quality](http://www.zilog.com/quality).

# Revision History

Each instance in Revision History reflects a change to this document from its previous revision. For more details, refer to the corresponding pages and appropriate links in the table below.

Date	Revision Level	Description	Page Number
September 2008	25	Added the references to F042A series back in <a href="#">Table 1</a> , <a href="#">Available Packages</a> , <a href="#">Table 5</a> , <a href="#">Table 7</a> , <a href="#">Table 13</a> , <a href="#">Ordering Information</a> sections.	<a href="#">3</a> , <a href="#">9</a> , <a href="#">16</a> , <a href="#">19</a> , <a href="#">37</a> , <a href="#">251</a>
May 2008	24	Changed title to Z8 Encore! XP F082A Series and removed references to F042A series in <a href="#">Table 1</a> , <a href="#">Available Packages</a> , <a href="#">Table 5</a> , <a href="#">Table 7</a> , <a href="#">Table 13</a> , <a href="#">Ordering Information</a> sections.	All
December 2007	23	Updated <a href="#">Figure 3</a> , <a href="#">Table 14</a> , <a href="#">Table 58</a> through <a href="#">Table 60</a> .	<a href="#">10</a> , <a href="#">41</a> , and <a href="#">95</a>
July 2007	22	Updated <a href="#">Table 15</a> and <a href="#">Table 128</a> . Updated Power consumption in <a href="#">Electrical Characteristics</a> chapter.	<a href="#">44</a> , <a href="#">221</a>
June 2007	21	Revision number update.	All

# Table of Contents

<b>Overview</b> .....	<b>1</b>
Features .....	1
Part Selection Guide .....	2
Block Diagram .....	4
CPU and Peripheral Overview .....	5
eZ8 CPU Features .....	5
10-Bit Analog-to-Digital Converter .....	5
Low-Power Operational Amplifier .....	6
Internal Precision Oscillator .....	6
Temperature Sensor .....	6
Analog Comparator .....	6
External Crystal Oscillator .....	6
Low Voltage Detector .....	6
On-Chip Debugger .....	6
Universal Asynchronous Receiver/Transmitter .....	7
Timers .....	7
General-Purpose Input/Output .....	7
Direct LED Drive .....	7
Flash Controller .....	7
Non-Volatile Data Storage .....	7
Interrupt Controller .....	8
Reset Controller .....	8
<b>Pin Description</b> .....	<b>9</b>
Available Packages .....	9
Pin Configurations .....	9
Signal Descriptions .....	11
Pin Characteristics .....	13
<b>Address Space</b> .....	<b>15</b>
Register File .....	15
Program Memory .....	15
Data Memory .....	17
Flash Information Area .....	17
<b>Register Map</b> .....	<b>19</b>



<b>Reset, Stop Mode Recovery, and Low Voltage Detection</b> .....	<b>23</b>
Reset Types .....	23
Reset Sources .....	25
Power-On Reset .....	25
Voltage Brownout Reset .....	26
Watchdog Timer Reset .....	27
External Reset Input .....	27
External Reset Indicator .....	28
On-Chip Debugger Initiated Reset .....	28
Stop Mode Recovery .....	28
Stop Mode Recovery Using Watchdog Timer Time-Out .....	29
Stop Mode Recovery Using a GPIO Port Pin Transition .....	29
Stop Mode Recovery Using the External RESET Pin .....	30
Low Voltage Detection .....	30
Reset Register Definitions .....	30
<b>Low-Power Modes</b> .....	<b>33</b>
STOP Mode .....	33
HALT Mode .....	34
Peripheral-Level Power Control .....	34
Power Control Register Definitions .....	34
<b>General-Purpose Input/Output</b> .....	<b>37</b>
GPIO Port Availability By Device .....	37
Architecture .....	38
GPIO Alternate Functions .....	38
Direct LED Drive .....	39
Shared Reset Pin .....	39
Shared Debug Pin .....	39
Crystal Oscillator Override .....	40
5 V Tolerance .....	40
External Clock Setup .....	40
GPIO Interrupts .....	45
GPIO Control Register Definitions .....	45
Port A–D Address Registers .....	46
Port A–D Control Registers .....	46
Port A–D Data Direction Sub-Registers .....	47
Port A–D Alternate Function Sub-Registers .....	47



Port A–C Input Data Registers .....	51
Port A–D Output Data Register .....	52
LED Drive Enable Register .....	52
LED Drive Level High Register .....	53
LED Drive Level Low Register .....	53
<b>Interrupt Controller .....</b>	<b>55</b>
Interrupt Vector Listing .....	55
Architecture .....	57
Operation .....	57
Master Interrupt Enable .....	57
Interrupt Vectors and Priority .....	58
Interrupt Assertion .....	58
Software Interrupt Assertion .....	59
Watchdog Timer Interrupt Assertion .....	59
Interrupt Control Register Definitions .....	60
Interrupt Request 0 Register .....	60
Interrupt Request 1 Register .....	61
Interrupt Request 2 Register .....	62
IRQ0 Enable High and Low Bit Registers .....	62
IRQ1 Enable High and Low Bit Registers .....	63
IRQ2 Enable High and Low Bit Registers .....	65
Interrupt Edge Select Register .....	66
Shared Interrupt Select Register .....	66
Interrupt Control Register .....	67
<b>Timers .....</b>	<b>69</b>
Architecture .....	69
Operation .....	70
Timer Operating Modes .....	70
Reading the Timer Count Values .....	82
Timer Pin Signal Operation .....	82
Timer Control Register Definitions .....	83
Timer 0–1 Control Registers .....	83
Timer 0–1 High and Low Byte Registers .....	87
Timer Reload High and Low Byte Registers .....	87
Timer 0-1 PWM High and Low Byte Registers .....	88
<b>Watchdog Timer .....</b>	<b>91</b>
Operation .....	91
Watchdog Timer Refresh .....	92



Watchdog Timer Time-Out Response . . . . .	92
Watchdog Timer Reload Unlock Sequence . . . . .	93
Watchdog Timer Calibration . . . . .	93
Watchdog Timer Control Register Definitions . . . . .	94
Watchdog Timer Control Register . . . . .	94
Watchdog Timer Reload Upper, High and Low Byte Registers . . . . .	94
<b>Universal Asynchronous Receiver/Transmitter . . . . .</b>	<b>97</b>
Architecture . . . . .	97
Operation . . . . .	98
Data Format . . . . .	98
Transmitting Data using the Polled Method . . . . .	99
Transmitting Data using the Interrupt-Driven Method . . . . .	100
Receiving Data using the Polled Method . . . . .	101
Receiving Data using the Interrupt-Driven Method . . . . .	102
Clear To Send (CTS) Operation . . . . .	103
MULTIPROCESSOR (9-bit) Mode . . . . .	103
External Driver Enable . . . . .	104
UART Interrupts . . . . .	105
UART Baud Rate Generator . . . . .	107
UART Control Register Definitions . . . . .	108
UART Control 0 and Control 1 Registers . . . . .	108
UART Status 0 Register . . . . .	111
UART Status 1 Register . . . . .	112
UART Transmit Data Register . . . . .	113
UART Receive Data Register . . . . .	113
UART Address Compare Register . . . . .	114
UART Baud Rate High and Low Byte Registers . . . . .	114
<b>Infrared Encoder/Decoder . . . . .</b>	<b>117</b>
Architecture . . . . .	117
Operation . . . . .	117
Transmitting IrDA Data . . . . .	118
Receiving IrDA Data . . . . .	119
Infrared Encoder/Decoder Control Register Definitions . . . . .	120
<b>Analog-to-Digital Converter . . . . .</b>	<b>121</b>
Architecture . . . . .	121
Operation . . . . .	122
Data Format . . . . .	122



Hardware Overflow	123
Automatic Powerdown	123
Single-Shot Conversion	123
Continuous Conversion	124
Interrupts	125
Calibration and Compensation	125
ADC Compensation Details	127
Input Buffer Stage	129
ADC Control Register Definitions	130
ADC Control Register 0	130
ADC Control/Status Register 1	132
ADC Data High Byte Register	132
ADC Data Low Byte Register	133
<b>Low Power Operational Amplifier</b>	<b>134</b>
Overview	134
Operation	134
<b>Comparator</b>	<b>135</b>
Operation	135
Comparator Control Register Definitions	136
<b>Temperature Sensor</b>	<b>139</b>
Temperature Sensor Operation	139
<b>Flash Memory</b>	<b>141</b>
Architecture	141
Flash Information Area	142
Operation	143
Flash Operation Timing Using the Flash Frequency Registers	145
Flash Code Protection Against External Access	145
Flash Code Protection Against Accidental Program and Erasure	145
Byte Programming	147
Page Erase	147
Mass Erase	147
Flash Controller Bypass	148
Flash Controller Behavior in DEBUG Mode	148
Flash Control Register Definitions	149
Flash Control Register	149
Flash Status Register	150
Flash Page Select Register	150





Flash Sector Protect Register . . . . .	151
Flash Frequency High and Low Byte Registers . . . . .	152
<b>Flash Option Bits . . . . .</b>	<b>153</b>
Operation . . . . .	153
Option Bit Configuration By Reset . . . . .	153
Option Bit Types . . . . .	154
Reading the Flash Information Page . . . . .	155
Flash Option Bit Control Register Definitions . . . . .	155
Trim Bit Address Register . . . . .	155
Trim Bit Data Register . . . . .	156
Flash Option Bit Address Space . . . . .	156
Flash Program Memory Address 0000H . . . . .	156
Flash Program Memory Address 0001H . . . . .	158
Trim Bit Address Space . . . . .	158
Trim Bit Address 0000H . . . . .	158
Trim Bit Address 0001H . . . . .	159
Trim Bit Address 0002H . . . . .	159
Trim Bit Address 0003H . . . . .	159
Trim Bit Address 0004H . . . . .	161
Zilog Calibration Data . . . . .	161
ADC Calibration Data . . . . .	161
Temperature Sensor Calibration Data . . . . .	164
Watchdog Timer Calibration Data . . . . .	164
Serialization Data . . . . .	165
Randomized Lot Identifier . . . . .	166
<b>Non-Volatile Data Storage . . . . .</b>	<b>169</b>
Operation . . . . .	169
NVDS Code Interface . . . . .	169
Byte Write . . . . .	169
Byte Read . . . . .	170
Power Failure Protection . . . . .	171
Optimizing NVDS Memory Usage for Execution Speed . . . . .	171
<b>On-Chip Debugger . . . . .</b>	<b>173</b>
Architecture . . . . .	173
Operation . . . . .	174
OCD Interface . . . . .	174
DEBUG Mode . . . . .	175



OCD Data Format	176
OCD Auto-Baud Detector/Generator	176
OCD Serial Errors	177
OCD Unlock Sequence (8-Pin Devices Only)	178
Breakpoints	178
Runtime Counter	179
On-Chip Debugger Commands	179
On-Chip Debugger Control Register Definitions	184
OCD Control Register	184
OCD Status Register	185
<b>Oscillator Control</b>	<b>187</b>
Operation	187
System Clock Selection	187
Clock Failure Detection and Recovery	189
Oscillator Control Register Definitions	190
<b>Crystal Oscillator</b>	<b>193</b>
Operating Modes	193
Crystal Oscillator Operation	193
Oscillator Operation with an External RC Network	195
<b>Internal Precision Oscillator</b>	<b>197</b>
Operation	197
<b>eZ8 CPU Instruction Set</b>	<b>199</b>
Assembly Language Programming Introduction	199
Assembly Language Syntax	200
eZ8 CPU Instruction Notation	200
eZ8 CPU Instruction Classes	202
eZ8 CPU Instruction Summary	207
<b>Opcode Maps</b>	<b>216</b>
<b>Electrical Characteristics</b>	<b>221</b>
Absolute Maximum Ratings	221
DC Characteristics	222
AC Characteristics	227
On-Chip Peripheral AC and DC Electrical Characteristics	229
General Purpose I/O Port Input Data Sample Timing	234



General Purpose I/O Port Output Timing .....	236
On-Chip Debugger Timing .....	237
UART Timing .....	238
<b>Packaging .....</b>	<b>241</b>
<b>Ordering Information .....</b>	<b>251</b>
<b>Index .....</b>	<b>261</b>
<b>Customer Support .....</b>	<b>271</b>

# Overview

Zilog's Z8 Encore!<sup>®</sup> MCU family of products are the first in a line of Zilog<sup>®</sup> microcontroller products based upon the 8-bit eZ8 CPU. Zilog's Z8 Encore! XP<sup>®</sup> F082A Series products expand upon Zilog's extensive line of 8-bit microcontrollers. The Flash in-circuit programming capability allows for faster development time and program changes in the field. The new eZ8 CPU is upward compatible with existing Z8<sup>®</sup> instructions. The rich peripheral set of the Z8 Encore! XP F082A Series makes it suitable for a variety of applications including motor control, security systems, home appliances, personal electronic devices, and sensors.

## Features

The key features of Z8 Encore! XP F082A Series products include:

- 20 MHz eZ8 CPU
- 1 KB, 2 KB, 4 KB, or 8 KB Flash memory with in-circuit programming capability
- 256 B, 512 B, or 1 KB register RAM
- Up to 128 B non-volatile data storage (NVDS)
- Internal precision oscillator trimmed to  $\pm 1\%$  accuracy
- External crystal oscillator, operating up to 20 MHz
- Optional 8-channel, 10-bit analog-to-digital converter (ADC)
- Optional on-chip temperature sensor
- On-chip analog comparator
- Optional on-chip low-power operational amplifier (LPO)
- Full-duplex UART
- The UART baud rate generator (BRG) can be configured and used as a basic 16-bit timer
- Infrared Data Association (IrDA)-compliant infrared encoder/decoders, integrated with UART
- Two enhanced 16-bit timers with capture, compare, and PWM capability
- Watchdog Timer (WDT) with dedicated internal RC oscillator
- Up to 20 vectored interrupts
- 6 to 25 I/O pins depending upon package

- Up to thirteen 5 V-tolerant input pins
- Up to 8 ports capable of direct LED drive with no current limit resistor required
- On-Chip Debugger (OCD)
- Voltage Brownout (VBO) protection
- Programmable low battery detection (LVD) (8-pin devices only)
- Bandgap generated precision voltage references available for the ADC, comparator, VBO, and LVD
- Power-On Reset (POR)
- 2.7 V to 3.6 V operating voltage
- 8-, 20-, and 28-pin packages
- 0 °C to +70 °C and -40 °C to +105 °C for operating temperature ranges

## Part Selection Guide

[Table 1](#) on page 3 identifies the basic features and package styles available for each device within the Z8 Encore! XP<sup>®</sup> F082A Series product line.

**Table 1. Z8 Encore! XP<sup>®</sup> F082A Series Family Part Selection Guide**

Part Number	Flash (KB)	RAM (B)	NVDS <sup>1</sup> (B)	I/O	Comparator	Advanced Analog <sup>2</sup>	ADC Inputs	Packages
Z8F082A	8	1024	0	6–23	Yes	Yes	4–8	8-, 20- and 28-pin
Z8F081A	8	1024	0	6–25	Yes	No	0	8-, 20- and 28-pin
Z8F042A	4	1024	128	6–23	Yes	Yes	4–8	8-, 20- and 28-pin
Z8F041A	4	1024	128	6–25	Yes	No	0	8-, 20- and 28-pin
Z8F022A	2	512	64	6–23	Yes	Yes	4–8	8-, 20- and 28-pin
Z8F021A	2	512	64	6–25	Yes	No	0	8-, 20- and 28-pin
Z8F012A	1	256	16	6–23	Yes	Yes	4–8	8-, 20- and 28-pin
Z8F011A	1	256	16	6–25	Yes	No	0	8-, 20- and 28-pin

<sup>1</sup>Non-volatile data storage.

<sup>2</sup>Advanced Analog includes ADC, temperature sensor, and low-power operational amplifier.

## Block Diagram

Figure 1 displays the block diagram of the architecture of the Z8 Encore! XP<sup>®</sup> F082A Series devices.

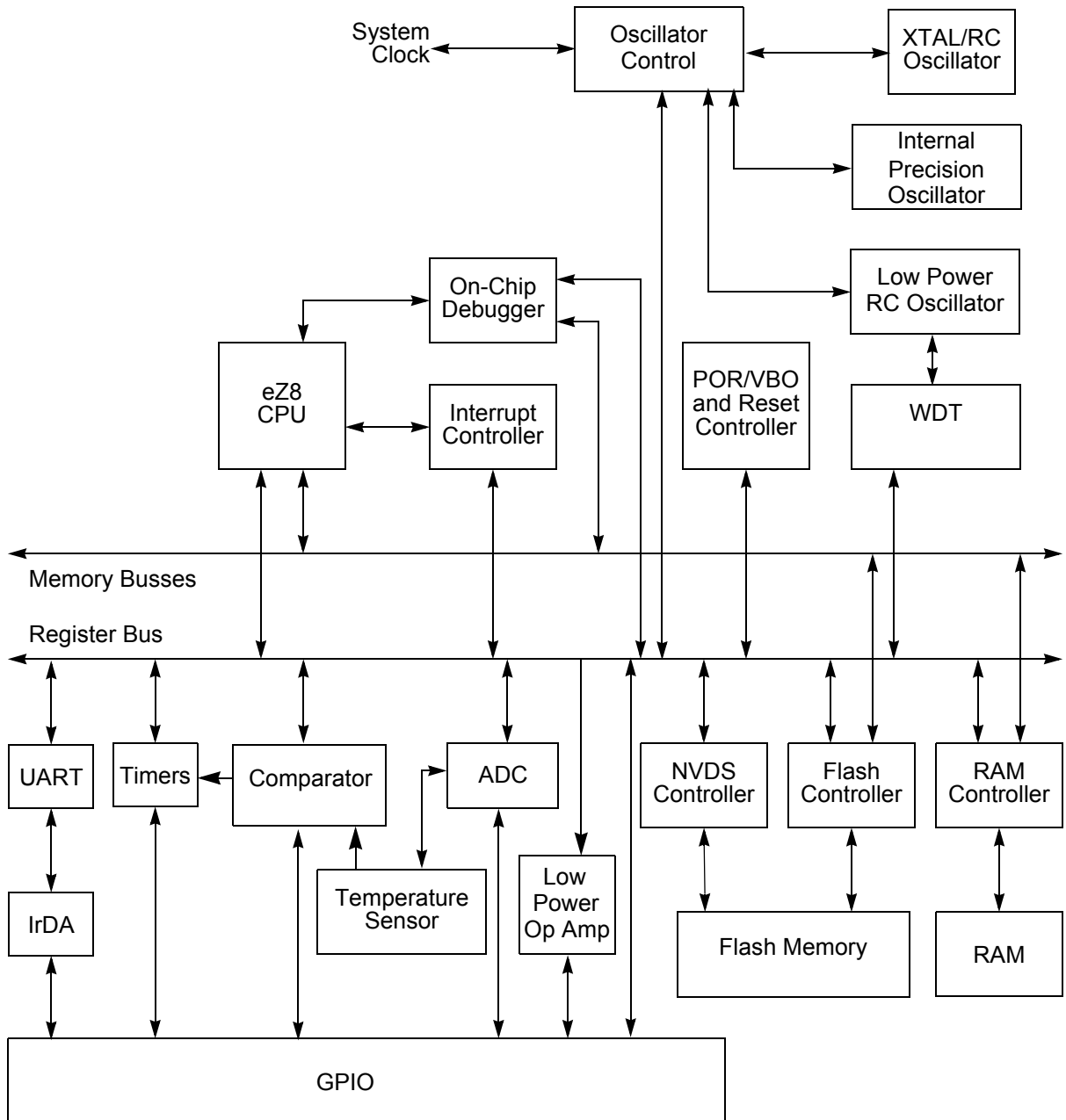

Figure 1. Z8 Encore! XP F082A Series Block Diagram

## CPU and Peripheral Overview

### eZ8 CPU Features

The eZ8 CPU, Zilog's latest 8-bit Central Processing Unit (CPU), meets the continuing demand for faster and more code-efficient microcontrollers. The eZ8 CPU executes a superset of the original Z8<sup>®</sup> instruction set. The features of eZ8 CPU include:

- Direct register-to-register architecture allows each register to function as an accumulator, improving execution time and decreasing the required program memory.
- Software stack allows much greater depth in subroutine calls and interrupts than hardware stacks.
- Compatible with existing Z8 code.
- Expanded internal Register File allows access of up to 4 KB.
- New instructions improve execution efficiency for code developed using higher-level programming languages, including C.
- Pipelined instruction fetch and execution.
- New instructions for improved performance including BIT, BSWAP, BTJ, CPC, LDC, LDCI, LEA, MULT, and SRL.
- New instructions support 12-bit linear addressing of the Register File.
- Up to 10 MIPS operation.
- C-Compiler friendly.
- 2 to 9 clock cycles per instruction.

For more information on eZ8 CPU, refer to *eZ8 CPU Core User Manual (UM0128)* available for download at [www.zilog.com](http://www.zilog.com).

### 10-Bit Analog-to-Digital Converter

The optional analog-to-digital converter (ADC) converts an analog input signal to a 10-bit binary number. The ADC accepts inputs from eight different analog input pins in both single-ended and differential modes. The ADC also features a unity gain buffer when high input impedance is required.



## Low-Power Operational Amplifier

The optional low-power operational amplifier (LPO) is a general-purpose amplifier primarily targeted for current sense applications. The LPO output may be routed internally to the ADC or externally to a pin.

## Internal Precision Oscillator

The internal precision oscillator (IPO) is a trimmable clock source that requires no external components.

## Temperature Sensor

The optional temperature sensor produces an analog output proportional to the device temperature. This signal can be sent to either the ADC or the analog comparator.

## Analog Comparator

The analog comparator compares the signal at an input pin with either an internal programmable voltage reference or a second input pin. The comparator output can be used to drive either an output pin or to generate an interrupt.

## External Crystal Oscillator

The crystal oscillator circuit provides highly accurate clock frequencies with the use of an external crystal, ceramic resonator or RC network.

## Low Voltage Detector

The low voltage detector (LVD) is able to generate an interrupt when the supply voltage drops below a user-programmable level. The LVD is available on 8-pin devices only.

## On-Chip Debugger

The Z8 Encore! XP<sup>®</sup> F082A Series products feature an integrated on-chip debugger (OCD) accessed via a single-pin interface. The OCD provides a rich-set of debugging capabilities, such as reading and writing registers, programming Flash memory, setting breakpoints, and executing code.

## Universal Asynchronous Receiver/Transmitter

The full-duplex universal asynchronous receiver/transmitter (UART) is included in all Z8 Encore! XP package types. The UART supports 8- and 9-bit data modes and selectable parity. The UART also supports multi-drop address processing in hardware. The UART baud rate generator (BRG) can be configured and used as a basic 16-bit timer.

## Timers

Two enhanced 16-bit reloadable timers can be used for timing/counting events or for motor control operations. These timers provide a 16-bit programmable reload counter and operate in ONE-SHOT, CONTINUOUS, GATED, CAPTURE, CAPTURE RESTART, COMPARE, CAPTURE and COMPARE, PWM SINGLE OUTPUT and PWM DUAL OUTPUT modes.

## General-Purpose Input/Output

The Z8 Encore! XP F082A Series features 6 to 25 port pins (Ports A–D) for general-purpose input/output (GPIO). The number of GPIO pins available is a function of package, and each pin is individually programmable. 5 V tolerant input pins are available on all I/Os on 8-pin devices and most I/Os on other package types.

## Direct LED Drive

The 20- and 28-pin devices support controlled current sinking output pins capable of driving LEDs without the need for a current limiting resistor. These LED drivers are independently programmable to four different intensity levels.

## Flash Controller

The Flash Controller programs and erases Flash memory. The Flash Controller supports several protection mechanisms against accidental program and erasure, as well as factory serialization and read protection.

## Non-Volatile Data Storage

The non-volatile data storage (NVDS) uses a hybrid hardware/software scheme to implement a byte programmable data memory and is capable of over 100,000 write cycles.

► **Note:** *Devices with 8 KB Flash memory do not include the NVDS feature.*

## Interrupt Controller

The Z8 Encore! XP<sup>®</sup> F082A Series products support up to 20 interrupts. These interrupts consist of 8 internal peripheral interrupts and 12 general-purpose I/O pin interrupt sources. The interrupts have three levels of programmable interrupt priority.

## Reset Controller

The Z8 Encore! XP F082A Series products can be reset using the  $\overline{\text{RESET}}$  pin, Power-On Reset, Watchdog Timer (WDT) time-out, STOP mode exit, or Voltage Brownout (VBO) warning signal. The  $\overline{\text{RESET}}$  pin is bi-directional, that is, it functions as reset source as well as a reset indicator.

# Pin Description

The Z8 Encore! XP<sup>®</sup> F082A Series products are available in a variety of packages styles and pin configurations. This chapter describes the signals and available pin configurations for each of the package styles. For information on physical package specifications, see [Packaging](#) on page 241.

## Available Packages

The following package styles are available for each device in the Z8 Encore! XP F082A Series product line:

- SOIC
  - 8-, 20-, and 28-pin
- PDIP
  - 8-, 20-, and 28-pin
- SSOP
  - 20- and 28- pin
- QFN (this is an MLF-S, a QFN style package with an 8-pin SOIC footprint)
  - 8-pin

In addition, the Z8 Encore! XP F082A Series devices are available both with and without advanced analog capability (ADC, temperature sensor and op amp). Devices Z8F082A, Z8F042A, Z8F022A, and Z8F012A contain the advanced analog, while devices Z8F081A, Z8F041A, Z8F021A, and Z8F011A do not have the advanced analog capability.

## Pin Configurations

[Figure 2](#) through [Figure 4](#) display the pin configurations for all the packages available in the Z8 Encore! XP F082A Series. See [Table 2](#) on page 11 for a description of the signals. The analog input alternate functions (ANAx) are not available on the Z8F081A, Z8F041A, Z8F021A, and Z8F011A devices. The analog supply pins (AV<sub>DD</sub> and AV<sub>SS</sub>) are also not available on these parts, and are replaced by PB6 and PB7.

At reset, all Port A, B and C pins default to an input state. In addition, any alternate functionality is not enabled, so the pins function as general purpose input ports until programmed otherwise. At powerup, the PD0 pin defaults to the RESET alternate function.

The pin configurations listed are preliminary and subject to change based on manufacturing limitations.

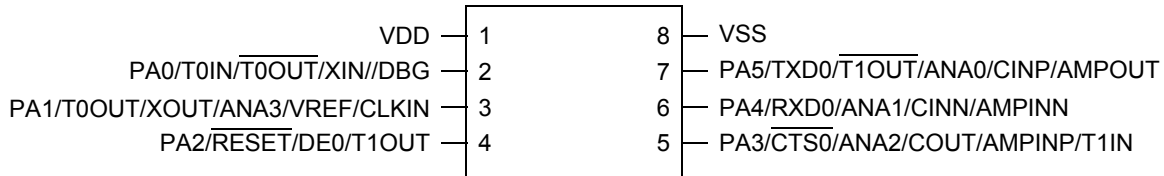

Figure 2. Z8F08xA, Z8F04xA, Z8F02xA, and Z8F01xA in 8-Pin SOIC, QFN/MLF-S, or PDIP Package

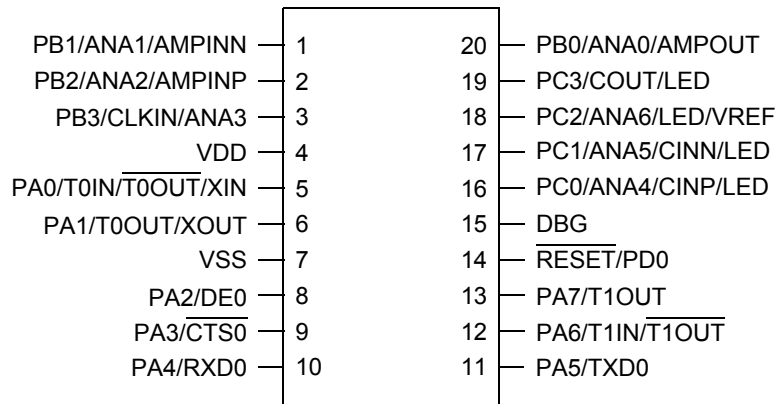

Figure 3. Z8F08xA, Z8F04xA, Z8F02xA, and Z8F01xA in 20-Pin SOIC, SSOP or PDIP Package

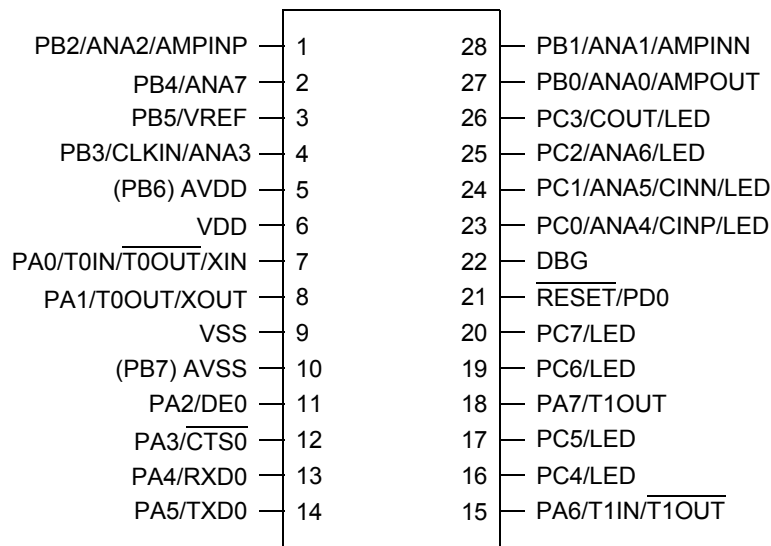

Figure 4. Z8F08xA, Z8F04xA, Z8F02xA, and Z8F01xA in 28-Pin SOIC, SSOP or PDIP Package

## Signal Descriptions

Table 2 describes the Z8 Encore! XP F082A Series signals. See [Pin Configurations](#) on page 9 to determine the signals available for the specific package styles.

**Table 2. Signal Descriptions**

Signal Mnemonic	I/O	Description
<b>General-Purpose I/O Ports A–D</b>		
PA[7:0]	I/O	Port A. These pins are used for general-purpose I/O.
PB[7:0]	I/O	Port B. These pins are used for general-purpose I/O. PB6 and PB7 are available only in those devices without an ADC.
PC[7:0]	I/O	Port C. These pins are used for general-purpose I/O.
PD[0]	I/O	Port D. This pin is used for general-purpose output only.
<b>Note:</b> PB6 and PB7 are only available in 28-pin packages without ADC. In 28-pin packages with ADC, they are replaced by AV <sub>DD</sub> and AV <sub>SS</sub> .		
<b>UART Controllers</b>		
TXD0	O	Transmit Data. This signal is the transmit output from the UART and IrDA.
RXD0	I	Receive Data. This signal is the receive input for the UART and IrDA.
$\overline{\text{CTS0}}$	I	Clear To Send. This signal is the flow control input for the UART.
DE	O	Driver Enable. This signal allows automatic control of external RS-485 drivers. This signal is approximately the inverse of the TXE (Transmit Empty) bit in the UART Status 0 register. The DE signal may be used to ensure the external RS-485 driver is enabled when data is transmitted by the UART.
<b>Timers</b>		
T0OUT/T1OUT	O	Timer Output 0–1. These signals are outputs from the timers.
$\overline{\text{T0OUT}}/\overline{\text{T1OUT}}$	O	Timer Complement Output 0–1. These signals are output from the timers in PWM Dual Output mode.
T0IN/T1IN	I	Timer Input 0–1. These signals are used as the capture, gating and counter inputs.
<b>Comparator</b>		
CINP/CINN	I	Comparator Inputs. These signals are the positive and negative inputs to the comparator.
COUT	O	Comparator Output.

Table 2. Signal Descriptions (Continued)

Signal Mnemonic	I/O	Description
<b>Analog</b>		
ANA[7:0]	I	Analog Port. These signals are used as inputs to the analog-to-digital converter (ADC).
VREF	I/O	Analog-to-digital converter reference voltage input, or buffered output for internal reference.
<b>Low-Power Operational Amplifier (LPO)</b>		
AMPINP/AMPINN	I	LPO inputs. If enabled, these pins drive the positive and negative amplifier inputs respectively.
AMPOUT	O	LPO output. If enabled, this pin is driven by the on-chip LPO.
<b>Oscillators</b>		
XIN	I	External Crystal Input. This is the input pin to the crystal oscillator. A crystal can be connected between it and the <b>XOUT</b> pin to form the oscillator. In addition, this pin is used with external RC networks or external clock drivers to provide the system clock.
XOUT	O	External Crystal Output. This pin is the output of the crystal oscillator. A crystal can be connected between it and the <b>XIN</b> pin to form the oscillator.
<b>Clock Input</b>		
CLKIN	I	Clock Input Signal. This pin may be used to input a TTL-level signal to be used as the system clock.
<b>LED Drivers</b>		
LED	O	Direct LED drive capability. All port C pins have the capability to drive an LED without any other external components. These pins have programmable drive strengths set by the GPIO block.
<b>On-Chip Debugger</b>		
DBG	I/O	Debug. This signal is the control and data input and output to and from the On-Chip Debugger.
 <b>Caution:</b> <i>The DBG pin is open-drain and requires a pull-up resistor to ensure proper operation.</i>		
<b>Reset</b>		
RESET	I/O	RESET. Generates a Reset when asserted (driven Low). Also serves as a reset indicator; the Z8 Encore! XP forces this pin low when in reset. This pin is open-drain and features an enabled internal pull-up resistor.

**Table 2. Signal Descriptions (Continued)**

Signal Mnemonic	I/O	Description
<b>Power Supply</b>		
V <sub>DD</sub>	I	Digital Power Supply.
AV <sub>DD</sub>	I	Analog Power Supply.
V <sub>SS</sub>	I	Digital Ground.
AV <sub>SS</sub>	I	Analog Ground.
<b>Note:</b> The AV <sub>DD</sub> and AV <sub>SS</sub> signals are available only in 28-pin packages with ADC. They are replaced by PB6 and PB7 on 28-pin packages without ADC.		

## Pin Characteristics

Table 3 describes the characteristics for each pin available on the Z8 Encore! XP F082A Series 20- and 28-pin devices. Data in Table 3 is sorted alphabetically by the pin symbol mnemonic.

Table 4 on page 14 provides detailed information about the characteristics for each pin available on the Z8 Encore! XP F082A Series 8-pin devices.

► **Note:** All six I/O pins on the 8-pin packages are 5 V-tolerant (unless the pull-up devices are enabled). The column in Table 3 below describes 5 V-tolerance for the 20- and 28-pin packages only.

**Table 3. Pin Characteristics (20- and 28-pin Devices)**

Symbol Mnemonic	Direction	Reset Direction	Active Low or Active High	Tristate Output	Internal Pull-up or Pull-down	Schmitt-Trigger Input	Open Drain Output	5 V Tolerance
AVDD	N/A	N/A	N/A	N/A	N/A	N/A	N/A	N/A
AVSS	N/A	N/A	N/A	N/A	N/A	N/A	N/A	NA
DBG	I/O	I	N/A	Yes	Yes	Yes	Yes	No
PA[7:0]	I/O	I	N/A	Yes	Programmable Pull-up	Yes	Yes, Programmable	PA[7:2] unless pullups enabled
PB[7:0]	I/O	I	N/A	Yes	Programmable Pull-up	Yes	Yes, Programmable	PB[7:6] unless pullups enabled



**Table 3. Pin Characteristics (20- and 28-pin Devices) (Continued)**

Symbol Mnemonic	Direction	Reset Direction	Active Low or Active High	Tristate Output	Internal Pull-up or Pull-down	Schmitt-Trigger Input	Open Drain Output	5 V Tolerance
PC[7:0]	I/O	I	N/A	Yes	Programmable Pull-up	Yes	Yes, Programmable	PC[7:3] unless pullups enabled
RESET/PD0	I/O	I/O (defaults to RESET)	Low (in Reset mode)	Yes (PD0 only)	Programmable for PD0; always on for RESET	Yes	Programmable for PD0; always on for RESET	Yes, unless pullups enabled
VDD	N/A	N/A	N/A	N/A			N/A	N/A
VSS	N/A	N/A	N/A	N/A			N/A	N/A

► **Note:** *PB6 and PB7 are available only in those devices without ADC.*

**Table 4. Pin Characteristics (8-Pin Devices)**

Symbol Mnemonic	Direction	Reset Direction	Active Low or Active High	Tristate Output	Internal Pull-up or Pull-down	Schmitt-Trigger Input	Open Drain Output	5 V Tolerance
PA0/DBG	I/O	I (but can change during reset if key sequence detected)	N/A	Yes	Programmable Pull-up	Yes	Yes, Programmable	Yes, unless pull-ups enabled
PA1	I/O	I	N/A	Yes	Programmable Pull-up	Yes	Yes, Programmable	Yes, unless pull-ups enabled
RESET/PA2	I/O	I/O (defaults to RESET)	Low (in Reset mode)	Yes	Programmable for PA2; always on for RESET	Yes	Programmable for PA2; always on for RESET	Yes, unless pull-ups enabled
PA[5:3]	I/O	I	N/A	Yes	Programmable Pull-up	Yes	Yes, Programmable	Yes, unless pull-ups enabled
V <sub>DD</sub>	N/A	N/A	N/A	N/A	N/A	N/A	N/A	N/A
V <sub>SS</sub>	N/A	N/A	N/A	N/A	N/A	N/A	N/A	N/A

# Address Space

The eZ8 CPU can access the following three distinct address spaces:

1. The Register File contains addresses for the general-purpose registers and the eZ8 CPU, peripheral, and general-purpose I/O port control registers.
2. The Program Memory contains addresses for all memory locations having executable code and/or data.
3. The Data Memory contains addresses for all memory locations that contain data only.

These three address spaces are covered briefly in the following subsections. For more information on eZ8 CPU and its address space, refer to *eZ8 CPU Core User Manual (UM0128)* available for download at [www.zilog.com](http://www.zilog.com).

## Register File

The Register File address space in the Z8 Encore!<sup>®</sup> MCU is 4 KB (4096 bytes). The Register File is composed of two sections: control registers and general-purpose registers. When instructions are executed, registers defined as sources are read, and registers defined as destinations are written. The architecture of the eZ8 CPU allows all general-purpose registers to function as accumulators, address pointers, index registers, stack areas, or scratch pad memory.

The upper 256 bytes of the 4 KB Register File address space are reserved for control of the eZ8 CPU, the on-chip peripherals, and the I/O ports. These registers are located at addresses from F00H to FFFH. Some of the addresses within the 256 B control register section are reserved (unavailable). Reading from a reserved Register File address returns an undefined value. Writing to reserved Register File addresses is not recommended and can produce unpredictable results.

The on-chip RAM always begins at address 000H in the Register File address space. The Z8 Encore! XP<sup>®</sup> F082A Series devices contain 256 B to 1 KB of on-chip RAM. Reading from Register File addresses outside the available RAM addresses (and not within the control register address space) returns an undefined value. Writing to these Register File addresses produces no effect.

## Program Memory

The eZ8 CPU supports 64 KB of Program Memory address space. The Z8 Encore! XP F082A Series devices contain 1 KB to 8 KB of on-chip Flash memory in the Program Memory address space, depending on the device. Reading from Program Memory

addresses outside the available Flash memory addresses returns FFH. Writing to these unimplemented Program Memory addresses produces no effect. [Table 5](#) describes the Program Memory Maps for the Z8 Encore! XP F082A Series products.

**Table 5. Z8 Encore! XP F082A Series Program Memory Maps**

Program Memory Address (Hex)	Function
<b>Z8F082A and Z8F081A Products</b>	
0000–0001	Flash Option Bits
0002–0003	Reset Vector
0004–0005	WDT Interrupt Vector
0006–0007	Illegal Instruction Trap
0008–0037	Interrupt Vectors*
0038–0039	Reserved
003A–003D	Oscillator Fail Trap Vectors
003E–1FFF	Program Memory
<b>Z8F042A and Z8F041A Products</b>	
0000–0001	Flash Option Bits
0002–0003	Reset Vector
0004–0005	WDT Interrupt Vector
0006–0007	Illegal Instruction Trap
0008–0037	Interrupt Vectors*
0038–0039	Reserved
003A–003D	Oscillator Fail Trap Vectors
003E–0FFF	Program Memory

**Table 5. Z8 Encore! XP F082A Series Program Memory Maps (Continued)**

Program Memory Address (Hex)	Function
<b>Z8F022A and Z8F021A Products</b>	
0000–0001	Flash Option Bits
0002–0003	Reset Vector
0004–0005	WDT Interrupt Vector
0006–0007	Illegal Instruction Trap
0008–0037	Interrupt Vectors*
0038–0039	Reserved
003A–003D	Oscillator Fail Trap Vectors
003E–07FF	Program Memory
<b>Z8F012A and Z8F011A Products</b>	
0000–0001	Flash Option Bits
0002–0003	Reset Vector
0004–0005	WDT Interrupt Vector
0006–0007	Illegal Instruction Trap
0008–0037	Interrupt Vectors*
0038–0039	Reserved
003A–003D	Oscillator Fail Trap Vectors
003E–03FF	Program Memory

\* See [Table 32](#) on page 56 for a list of the interrupt vectors.

## Data Memory

The Z8 Encore! XP F082A Series does not use the eZ8 CPU's 64 KB Data Memory address space.

## Flash Information Area

[Table 6](#) on page 18 describes the Z8 Encore! XP F082A Series Flash Information Area. This 128 B Information Area is accessed by setting bit 7 of the Flash Page Select Register to 1. When access is enabled, the Flash Information Area is mapped into the Program Memory and overlays the 128 bytes at addresses FE00H to FF7FH. When the Information Area access is enabled, all reads from these Program Memory addresses return the Infor-



mation Area data rather than the Program Memory data. Access to the Flash Information Area is read-only.

**Table 6. Z8 Encore! XP F082A Series Flash Memory Information Area Map**

<b>Program Memory Address (Hex)</b>	<b>Function</b>
FE00–FE3F	Zilog Option Bits/Calibration Data
FE40–FE53	Part Number 20-character ASCII alphanumeric code Left justified and filled with FFH
FE54–FE5F	Reserved
FE60–FE7F	Zilog Calibration Data
FE80–FFFF	Reserved

# Register Map

Table 7 provides the address map for the Register File of the Z8 Encore! XP<sup>®</sup> F082A Series devices. Not all devices and package styles in the Z8 Encore! XP F082A Series support the ADC, or all of the GPIO Ports. Consider registers for unimplemented peripherals as Reserved.

**Table 7. Register File Address Map**

Address (Hex)	Register Description	Mnemonic	Reset (Hex)	Page No
<b>General-Purpose RAM</b>				
<b>Z8F082A/Z8F081A Devices</b>				
000–3FF	General-Purpose Register File RAM	—	XX	
400–EFF	Reserved	—	XX	
<b>Z8F042A/Z8F041A Devices</b>				
000–3FF	General-Purpose Register File RAM	—	XX	
400–EFF	Reserved	—	XX	
<b>Z8F022A/Z8F021A Devices</b>				
000–1FF	General-Purpose Register File RAM	—	XX	
200–EFF	Reserved	—	XX	
<b>Z8F012A/Z8F011A Devices</b>				
000–0FF	General-Purpose Register File RAM	—	XX	
100–EFF	Reserved	—	XX	
<b>Timer 0</b>				
F00	Timer 0 High Byte	T0H	00	87
F01	Timer 0 Low Byte	T0L	01	87
F02	Timer 0 Reload High Byte	T0RH	FF	88
F03	Timer 0 Reload Low Byte	T0RL	FF	88
F04	Timer 0 PWM High Byte	T0PWMH	00	88
F05	Timer 0 PWM Low Byte	T0PWML	00	89
F06	Timer 0 Control 0	T0CTL0	00	83
F07	Timer 0 Control 1	T0CTL1	00	84
<b>Timer 1</b>				
F08	Timer 1 High Byte	T1H	00	87
F09	Timer 1 Low Byte	T1L	01	87
F0A	Timer 1 Reload High Byte	T1RH	FF	88
XX=Undefined				

**Table 7. Register File Address Map (Continued)**

Address (Hex)	Register Description	Mnemonic	Reset (Hex)	Page No
F0B	Timer 1 Reload Low Byte	T1RL	FF	88
F0C	Timer 1 PWM High Byte	T1PWMH	00	88
F0D	Timer 1 PWM Low Byte	T1PWML	00	89
F0E	Timer 1 Control 0	T1CTL0	00	83
F0F	Timer 1 Control 1	T1CTL1	00	84
F10–F6F	Reserved	—	XX	
<b>UART</b>				
F40	UART Transmit/Receive Data Registers	TXD, RXD	XX	113
F41	UART Status 0 Register	U0STAT0	00	111
F42	UART Control 0 Register	U0CTL0	00	108
F43	UART Control 1 Register	U0CTL1	00	108
F44	UART Status 1 Register	U0STAT1	00	112
F45	UART Address Compare Register	U0ADDR	00	114
F46	UART Baud Rate High Byte Register	U0BRH	FF	114
F47	UART Baud Rate Low Byte Register	U0BRL	FF	114
<b>Analog-to-Digital Converter (ADC)</b>				
F70	ADC Control 0	ADCCTL0	00	130
F71	ADC Control 1	ADCCTL1	80	130
F72	ADC Data High Byte	ADCD_H	XX	133
F73	ADC Data Low Bits	ADCD_L	XX	133
F74–F7F	Reserved	—	XX	
<b>Low Power Control</b>				
F80	Power Control 0	PWRCTL0	80	35
F81	Reserved	—	XX	
<b>LED Controller</b>				
F82	LED Drive Enable	LEDEN	00	52
F83	LED Drive Level High Byte	LEDLVLH	00	53
F84	LED Drive Level Low Byte	LEDLVLL	00	54
F85	Reserved	—	XX	
<b>Oscillator Control</b>				
F86	Oscillator Control	OSCCTL	A0	190
F87–F8F	Reserved	—	XX	
<b>Comparator 0</b>				
F90	Comparator 0 Control	CMP0	14	136
XX=Undefined				

**Table 7. Register File Address Map (Continued)**

Address (Hex)	Register Description	Mnemonic	Reset (Hex)	Page No
F91–FBF	Reserved	—	XX	
<b>Interrupt Controller</b>				
FC0	Interrupt Request 0	IRQ0	00	60
FC1	IRQ0 Enable High Bit	IRQ0ENH	00	63
FC2	IRQ0 Enable Low Bit	IRQ0ENL	00	63
FC3	Interrupt Request 1	IRQ1	00	61
FC4	IRQ1 Enable High Bit	IRQ1ENH	00	64
FC5	IRQ1 Enable Low Bit	IRQ1ENL	00	64
FC6	Interrupt Request 2	IRQ2	00	62
FC7	IRQ2 Enable High Bit	IRQ2ENH	00	65
FC8	IRQ2 Enable Low Bit	IRQ2ENL	00	65
FC9–FCC	Reserved	—	XX	
FCD	Interrupt Edge Select	IRQES	00	67
FCE	Shared Interrupt Select	IRQSS	00	67
FCF	Interrupt Control	IRQCTL	00	67
<b>GPIO Port A</b>				
FD0	Port A Address	PAADDR	00	45
FD1	Port A Control	PACTL	00	47
FD2	Port A Input Data	PAIN	XX	47
FD3	Port A Output Data	PAOUT	00	47
<b>GPIO Port B</b>				
FD4	Port B Address	PBADDR	00	45
FD5	Port B Control	PBCTL	00	47
FD6	Port B Input Data	PBIN	XX	47
FD7	Port B Output Data	PBOUT	00	47
<b>GPIO Port C</b>				
FD8	Port C Address	PCADDR	00	45
FD9	Port C Control	PCCTL	00	47
FDA	Port C Input Data	PCIN	XX	47
FDB	Port C Output Data	PCOUT	00	47
<b>GPIO Port D</b>				
FDC	Port D Address	PDADDR	00	45
FDD	Port D Control	PDCTL	00	47
FDE	Reserved	—	XX	
XX=Undefined				



**Table 7. Register File Address Map (Continued)**

Address (Hex)	Register Description	Mnemonic	Reset (Hex)	Page No
FDF	Port D Output Data	PDOUT	00	47
FE0–FEF	Reserved	—	XX	
<b>Watchdog Timer (WDT)</b>				
FF0	Reset Status (Read-only)	RSTSTAT	X0	30
	Watchdog Timer Control (Write-only)	WDTCTL	N/A	94
FF1	Watchdog Timer Reload Upper Byte	WDTU	00	95
FF2	Watchdog Timer Reload High Byte	WDTH	04	95
FF3	Watchdog Timer Reload Low Byte	WDTL	00	95
FF4–FF5	Reserved	—	XX	
<b>Trim Bit Control</b>				
FF6	Trim Bit Address	TRMADR	00	155
FF7	Trim Bit Data	TRMDR	00	156
<b>Flash Memory Controller</b>				
FF8	Flash Control	FCTL	00	149
FF8	Flash Status	FSTAT	00	150
FF9	Flash Page Select	FPS	00	151
	Flash Sector Protect	FPROT	00	151
FFA	Flash Programming Frequency High Byte	FFREQH	00	152
FFB	Flash Programming Frequency Low Byte	FFREQL	00	152
<b>eZ8 CPU</b>				
FFC	Flags	—	XX	Refer to eZ8
FFD	Register Pointer	RP	XX	CPU Core
FFE	Stack Pointer High Byte	SPH	XX	User Manual
FFF	Stack Pointer Low Byte	SPL	XX	(UM0128)
XX=Undefined				

# Reset, Stop Mode Recovery, and Low Voltage Detection

The Reset Controller within the Z8 Encore! XP<sup>®</sup> F082A Series controls Reset and Stop Mode Recovery operation and provides indication of low supply voltage conditions. In typical operation, the following events cause a Reset:

- Power-On Reset (POR)
- Voltage Brownout (VBO)
- Watchdog Timer time-out (when configured by the WDT\_RES Flash Option Bit to initiate a reset)
- External  $\overline{\text{RESET}}$  pin assertion (when the alternate RESET function is enabled by the GPIO register)
- On-chip debugger initiated Reset (OCDCTL[0] set to 1)

When the device is in STOP mode, a Stop Mode Recovery is initiated by either of the following:

- Watchdog Timer time-out
- GPIO Port input pin transition on an enabled Stop Mode Recovery source

The low voltage detection circuitry on the device (available on the 8-pin product versions only) performs the following functions:

- Generates the VBO reset when the supply voltage drops below a minimum safe level.
- Generates an interrupt when the supply voltage drops below a user-defined level (8-pin devices only).

## Reset Types

The Z8 Encore! XP F082A Series provides several different types of Reset operation. Stop Mode Recovery is considered as a form of Reset. [Table 8](#) lists the types of Reset and their operating characteristics. The System Reset is longer if the external crystal oscillator is enabled by the Flash option bits, allowing additional time for oscillator start-up.

**Table 8. Reset and Stop Mode Recovery Characteristics and Latency**

Reset Characteristics and Latency			
Reset Type	Control Registers	eZ8 CPU	Reset Latency (Delay)
System Reset	Reset (as applicable)	Reset	66 Internal Precision Oscillator Cycles
System Reset with Crystal Oscillator Enabled	Reset (as applicable)	Reset	5000 Internal Precision Oscillator Cycles
Stop Mode Recovery	Unaffected, except WDT_CTL and OSC_CTL registers	Reset	66 Internal Precision Oscillator Cycles + IPO startup time
Stop Mode Recovery with Crystal Oscillator Enabled	Unaffected, except WDT_CTL and OSC_CTL registers	Reset	5000 Internal Precision Oscillator Cycles

During a System Reset or Stop Mode Recovery, the Internal Precision Oscillator requires 4  $\mu$ s to start up. Then the Z8 Encore! XP F082A Series device is held in Reset for 66 cycles of the Internal Precision Oscillator. If the crystal oscillator is enabled in the Flash option bits, this reset period is increased to 5000 IPO cycles. When a reset occurs because of a low voltage condition or Power-On Reset (POR), this delay is measured from the time that the supply voltage first exceeds the POR level. If the external pin reset remains asserted at the end of the reset period, the device remains in reset until the pin is deasserted.

At the beginning of Reset, all GPIO pins are configured as inputs with pull-up resistor disabled, except PD0 (or PA2 on 8-pin devices) which is shared with the reset pin. On reset, the PD0 is configured as a bidirectional open-drain reset. The pin is internally driven low during port reset, after which the user code may reconfigure this pin as a general purpose output.

During Reset, the eZ8 CPU and on-chip peripherals are idle; however, the on-chip crystal oscillator and Watchdog Timer oscillator continue to run.

Upon Reset, control registers within the Register File that have a defined Reset value are loaded with their reset values. Other control registers (including the Stack Pointer, Register Pointer, and Flags) and general-purpose RAM are undefined following Reset. The eZ8 CPU fetches the Reset vector at Program Memory addresses 0002H and 0003H and loads that value into the Program Counter. Program execution begins at the Reset vector address.

As the control registers are re-initialized by a system reset, the system clock after reset is always the IPO. The software must reconfigure the oscillator control block, such that the correct system clock source is enabled and selected.

## Reset Sources

Table 9 lists the possible sources of a system reset.

**Table 9. Reset Sources and Resulting Reset Type**

Operating Mode	Reset Source	Special Conditions
NORMAL or HALT modes	Power-On Reset/Voltage Brownout	Reset delay begins after supply voltage exceeds POR level.
	Watchdog Timer time-out when configured for Reset	None.
	$\overline{\text{RESET}}$ pin assertion	All reset pulses less than three system clocks in width are ignored.
	On-Chip Debugger initiated Reset (OCDCTL[0] set to 1)	System Reset, except the On-Chip Debugger is unaffected by the reset.
STOP mode	Power-On Reset/Voltage Brownout	Reset delay begins after supply voltage exceeds POR level.
	$\overline{\text{RESET}}$ pin assertion	All reset pulses less than the specified analog delay are ignored. See Table 131 on page 229.
	DBG pin driven Low	None.

### Power-On Reset

Z8 Encore! XP F082A Series devices contain an internal Power-On Reset circuit. The POR circuit monitors the supply voltage and holds the device in the Reset state until the supply voltage reaches a safe operating level. After the supply voltage exceeds the POR voltage threshold ( $V_{\text{POR}}$ ), the device is held in the Reset state until the POR Counter has timed out. If the crystal oscillator is enabled by the option bits, this timeout is longer.

After the Z8 Encore! XP F082A Series device exits the Power-On Reset state, the eZ8 CPU fetches the Reset vector. Following Power-On Reset, the POR status bit in the Reset Status (RSTSTAT) register is set to 1.

Figure 5 displays Power-On Reset operation. See [Electrical Characteristics](#) on page 221 for the POR threshold voltage ( $V_{\text{POR}}$ ).

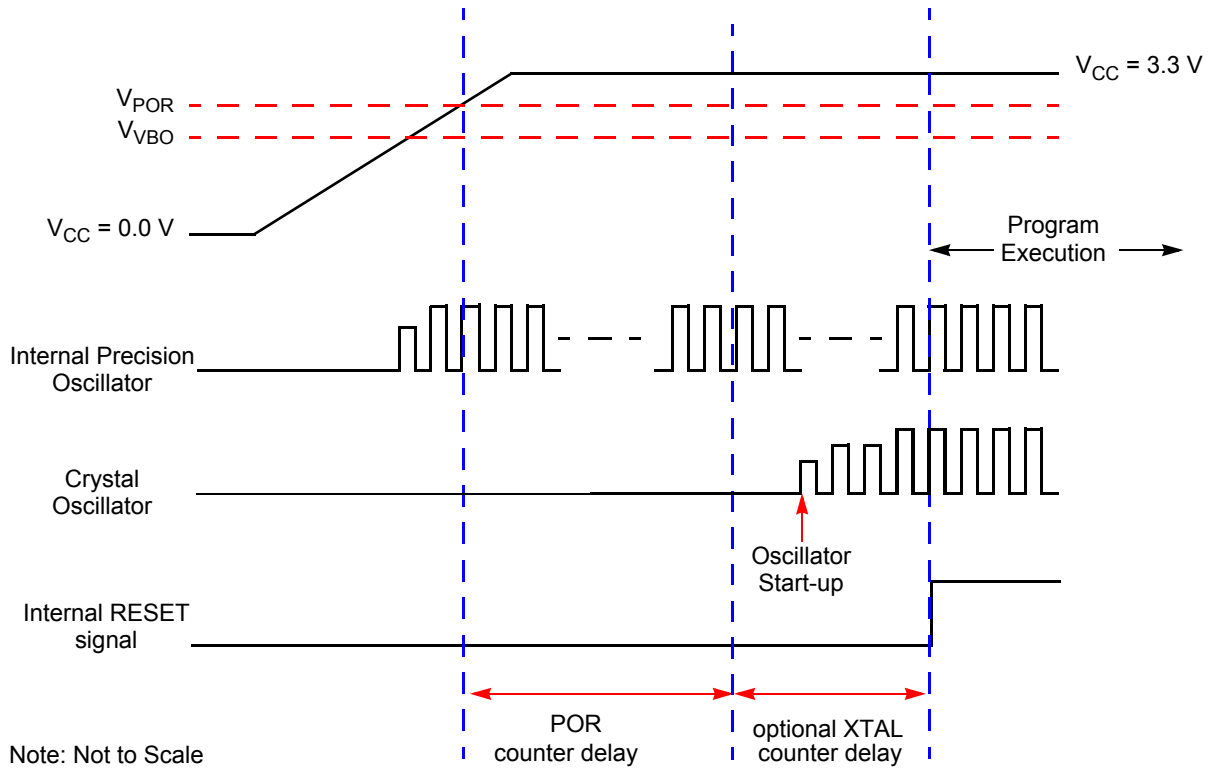

Figure 5. Power-On Reset Operation

## Voltage Brownout Reset

The devices in the Z8 Encore! XP F082A Series provide low Voltage Brownout (VBO) protection. The VBO circuit senses when the supply voltage drops to an unsafe level (below the VBO threshold voltage) and forces the device into the Reset state. While the supply voltage remains below the Power-On Reset voltage threshold ( $V_{POR}$ ), the VBO block holds the device in the Reset.

After the supply voltage again exceeds the Power-On Reset voltage threshold, the device progresses through a full System Reset sequence, as described in the Power-On Reset section. Following Power-On Reset, the POR status bit in the Reset Status (RSTSTAT) register is set to 1. [Figure 6](#) displays Voltage Brownout operation. See [Electrical Characteristics](#) on page 221 for the VBO and POR threshold voltages ( $V_{VBO}$  and  $V_{POR}$ ).

The Voltage Brownout circuit can be either enabled or disabled during STOP mode. Operation during STOP mode is set by the VBO\_AO Flash Option Bit. See [Flash Option Bits](#) for information about configuring VBO\_AO.

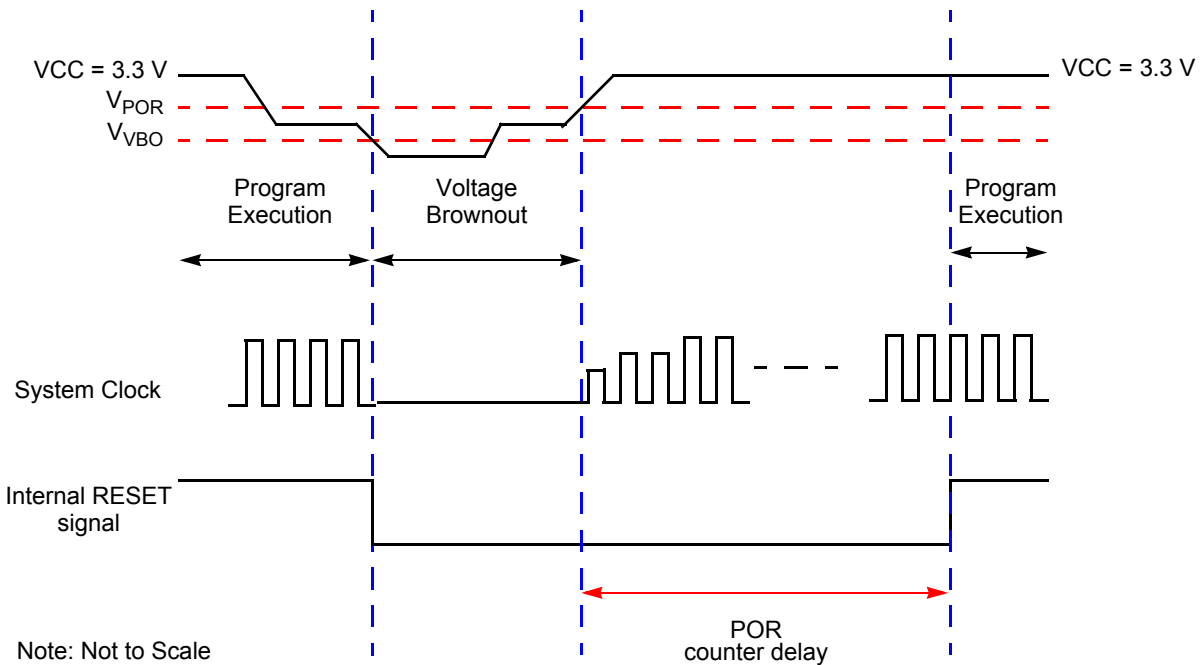

**Figure 6. Voltage Brownout Reset Operation**

The POR level is greater than the VBO level by the specified hysteresis value. This ensures that the device undergoes a Power-On Reset after recovering from a VBO condition.

### Watchdog Timer Reset

If the device is in NORMAL or HALT mode, the Watchdog Timer can initiate a System Reset at time-out if the WDT\_RES Flash Option Bit is programmed to 1. This is the unprogrammed state of the WDT\_RES Flash Option Bit. If the bit is programmed to 0, it configures the Watchdog Timer to cause an interrupt, not a System Reset, at time-out.

The WDT bit in the Reset Status (RSTSTAT) register is set to signify that the reset was initiated by the Watchdog Timer.

### External Reset Input

The  $\overline{\text{RESET}}$  pin has a Schmitt-Triggered input and an internal pull-up resistor. Once the  $\overline{\text{RESET}}$  pin is asserted for a minimum of four system clock cycles, the device progresses through the System Reset sequence. Because of the possible asynchronicity of the system clock and reset signals, the required reset duration may be as short as three clock periods

and as long as four. A reset pulse three clock cycles in duration might trigger a reset; a pulse four cycles in duration always triggers a reset.

While the  $\overline{\text{RESET}}$  input pin is asserted Low, the Z8 Encore! XP<sup>®</sup> F082A Series devices remain in the Reset state. If the  $\overline{\text{RESET}}$  pin is held Low beyond the System Reset time-out, the device exits the Reset state on the system clock rising edge following  $\overline{\text{RESET}}$  pin deassertion. Following a System Reset initiated by the external  $\overline{\text{RESET}}$  pin, the EXT status bit in the Reset Status (RSTSTAT) register is set to 1.

## External Reset Indicator

During System Reset or when enabled by the GPIO logic (see [Port A–D Control Registers](#) on page 46), the  $\overline{\text{RESET}}$  pin functions as an open-drain (active Low) reset mode indicator in addition to the input functionality. This reset output feature allows a Z8 Encore! XP F082A Series device to reset other components to which it is connected, even if that reset is caused by internal sources such as POR, VBO or WDT events.

After an internal reset event occurs, the internal circuitry begins driving the  $\overline{\text{RESET}}$  pin Low. The  $\overline{\text{RESET}}$  pin is held Low by the internal circuitry until the appropriate delay listed in [Table 8](#) has elapsed.

## On-Chip Debugger Initiated Reset

A Power-On Reset can be initiated using the On-Chip Debugger by setting the RST bit in the OCD Control register. The On-Chip Debugger block is not reset but the rest of the chip goes through a normal system reset. The RST bit automatically clears during the system reset. Following the system reset the POR bit in the Reset Status (RSTSTAT) register is set.

## Stop Mode Recovery

STOP mode is entered by execution of a STOP instruction by the eZ8 CPU. See [Low-Power Modes](#) on page 33 for detailed STOP mode information. During Stop Mode Recovery (SMR), the CPU is held in reset for 66 IPO cycles if the crystal oscillator is disabled or 5000 cycles if it is enabled. The SMR delay (see [Table 131](#) on page 229)  $T_{\text{SMR}}$ , also includes the time required to start up the IPO.

Stop Mode Recovery does not affect on-chip registers other than the Watchdog Timer Control register (WDTCTL) and the Oscillator Control register (OSCCTL). After any Stop Mode Recovery, the IPO is enabled and selected as the system clock. If another system clock source is required, the Stop Mode Recovery code must reconfigure the oscillator control block such that the correct system clock source is enabled and selected.

The eZ8 CPU fetches the Reset vector at Program Memory addresses 0002H and 0003H and loads that value into the Program Counter. Program execution begins at the Reset

vector address. Following Stop Mode Recovery, the STOP bit in the Reset Status (RSTSTAT) Register is set to 1. Table 10 lists the Stop Mode Recovery sources and resulting actions. The text following provides more detailed information about each of the Stop Mode Recovery sources.

**Table 10. Stop Mode Recovery Sources and Resulting Action**

Operating Mode	Stop Mode Recovery Source	Action
STOP mode	Watchdog Timer time-out when configured for Reset	Stop Mode Recovery
	Watchdog Timer time-out when configured for interrupt	Stop Mode Recovery followed by interrupt (if interrupts are enabled)
	Data transition on any GPIO Port pin enabled as a Stop Mode Recovery source	Stop Mode Recovery
	Assertion of external $\overline{\text{RESET}}$ Pin	System Reset
	Debug Pin driven Low	System Reset

### Stop Mode Recovery Using Watchdog Timer Time-Out

If the Watchdog Timer times out during STOP mode, the device undergoes a Stop Mode Recovery sequence. In the Reset Status (RSTSTAT) register, the WDT and STOP bits are set to 1. If the Watchdog Timer is configured to generate an interrupt upon time-out and the Z8 Encore! XP F082A Series device is configured to respond to interrupts, the eZ8 CPU services the Watchdog Timer interrupt request following the normal Stop Mode Recovery sequence.

### Stop Mode Recovery Using a GPIO Port Pin Transition

Each of the GPIO Port pins may be configured as a Stop Mode Recovery input source. On any GPIO pin enabled as a Stop Mode Recovery source, a change in the input pin value (from High to Low or from Low to High) initiates Stop Mode Recovery.

► **Note:** *The SMR pulses shorter than specified does not trigger a recovery (see Table 131 on page 229). When this happens, the STOP bit in the Reset Status (RSTSTAT) register is set to 1.*



**Caution:** *In STOP mode, the GPIO Port Input Data registers (PxIN) are disabled. The Port Input Data registers record the Port transition only if the signal stays on the Port pin through the end of the Stop Mode Recovery delay. As a result, short pulses on the Port pin can*



*initiate Stop Mode Recovery without being written to the Port Input Data register or without initiating an interrupt (if enabled for that pin).*

## Stop Mode Recovery Using the External $\overline{\text{RESET}}$ Pin

When the Z8 Encore! XP F082A Series device is in STOP mode and the external  $\overline{\text{RESET}}$  pin is driven Low, a system reset occurs. Because of a glitch filter operating on the  $\overline{\text{RESET}}$  pin, the Low pulse must be greater than the minimum width specified, or it is ignored. See [Electrical Characteristics](#) on page 221 for details.

## Low Voltage Detection

In addition to the Voltage Brownout (VBO) Reset described above, it is also possible to generate an interrupt when the supply voltage drops below a user-selected value. For details about configuring the Low Voltage Detection (LVD) and the threshold levels available, see [Trim Bit Address 0003H](#) on page 159. The LVD function is available on the 8-pin product versions only.

When the supply voltage drops below the LVD threshold, the LVD bit of the Reset Status (RSTSTAT) register is set to one. This bit remains one until the low-voltage condition goes away. Reading or writing this bit does not clear it. The LVD circuit can also generate an interrupt when so enabled, see [Interrupt Vectors and Priority](#) on page 58. The LVD bit is NOT latched, so enabling the interrupt is the only way to guarantee detection of a transient low voltage event.

The LVD functionality depends on circuitry shared with the VBO block; therefore, disabling the VBO also disables the LVD.

## Reset Register Definitions

The following sections define the Reset registers.

### Reset Status Register

The Reset Status (RSTSTAT) register is a read-only register that indicates the source of the most recent Reset event, indicates a Stop Mode Recovery event, and indicates a Watchdog Timer time-out. Reading this register resets the upper four bits to 0.

This register shares its address with the Watchdog Timer control register, which is write-only (see [Table 11](#) on page 31).

**Table 11. Reset Status Register (RSTSTAT)**

<b>BITS</b>	<b>7</b>	<b>6</b>	<b>5</b>	<b>4</b>	<b>3</b>	<b>2</b>	<b>1</b>	<b>0</b>
<b>FIELD</b>	POR	STOP	WDT	EXT	Reserved			LVD
<b>RESET</b>	See descriptions below			0	0	0	0	0
<b>R/W</b>	R	R	R	R	R	R	R	R
<b>ADDR</b>	FF0H							

<b>Reset or Stop Mode Recovery Event</b>	<b>POR</b>	<b>STOP</b>	<b>WDT</b>	<b>EXT</b>
Power-On Reset	1	0	0	0
Reset using RESET pin assertion	0	0	0	1
Reset using Watchdog Timer time-out	0	0	1	0
Reset using the On-Chip Debugger (OCTCTL[1] set to 1)	1	0	0	0
Reset from STOP Mode using DBG Pin driven Low	1	0	0	0
Stop Mode Recovery using GPIO pin transition	0	1	0	0
Stop Mode Recovery using Watchdog Timer time-out	0	1	1	0

**POR**—Power-On Reset Indicator

If this bit is set to 1, a Power-On Reset event occurs. This bit is reset to 0 if a WDT time-out or Stop Mode Recovery occurs. This bit is also reset to 0 when the register is read.

**STOP**—Stop Mode Recovery Indicator

If this bit is set to 1, a Stop Mode Recovery occurs. If the STOP and WDT bits are both set to 1, the Stop Mode Recovery occurs because of a WDT time-out. If the STOP bit is 1 and the WDT bit is 0, the Stop Mode Recovery was not caused by a WDT time-out. This bit is reset by a Power-On Reset or a WDT time-out that occurred while not in STOP mode. Reading this register also resets this bit.

**WDT**—Watchdog Timer Time-Out Indicator

If this bit is set to 1, a WDT time-out occurs. A POR resets this pin. A Stop Mode Recovery from a change in an input pin also resets this bit. Reading this register resets this bit. This read must occur before clearing the WDT interrupt.

**EXT**—External Reset Indicator

If this bit is set to 1, a Reset initiated by the external  $\overline{\text{RESET}}$  pin occurs. A Power-On Reset or a Stop Mode Recovery from a change in an input pin resets this bit. Reading this register resets this bit.

**Reserved**—Must be 0.

**LVD**—Low Voltage Detection Indicator

If this bit is set to 1 the current state of the supply voltage is below the low voltage detection threshold. This value is not latched but is a real-time indicator of the supply voltage level.



# Low-Power Modes

The Z8 Encore! XP F082A Series products contain power-saving features. The highest level of power reduction is provided by the STOP mode, in which nearly all device functions are powered down. The next lower level of power reduction is provided by the HALT mode, in which the CPU is powered down.

Further power savings can be implemented by disabling individual peripheral blocks while in Active mode (defined as being in neither STOP nor HALT mode).

## STOP Mode

Executing the eZ8 CPU's STOP instruction places the device into STOP mode, powering down all peripherals except the Voltage Brownout detector, the Low-power Operational Amplifier and the Watchdog Timer. These three blocks may also be disabled for additional power savings. Specifically, the operating characteristics are:

- Primary crystal oscillator and internal precision oscillator are stopped; XIN and XOUT (if previously enabled) are disabled, and PA0/PA1 revert to the states programmed by the GPIO registers.
- System clock is stopped.
- eZ8 CPU is stopped.
- Program counter (PC) stops incrementing.
- Watchdog Timer's internal RC oscillator continues to operate if enabled by the Oscillator Control register.
- If enabled, the Watchdog Timer logic continues to operate.
- If enabled for operation in STOP mode by the associated Flash Option Bit, the Voltage Brownout protection circuit continues to operate.
- Low-power operational amplifier continues to operate if enabled by the Power Control register to do so.
- All other on-chip peripherals are idle.

To minimize current in STOP mode, all GPIO pins that are configured as digital inputs must be driven to one of the supply rails ( $V_{CC}$  or GND). Additionally, any GPIOs configured as outputs must also be driven to one of the supply rails. The device can be brought out of STOP mode using Stop Mode Recovery. For more information on Stop Mode Recovery, see [Reset, Stop Mode Recovery, and Low Voltage Detection](#) on page 23.

## HALT Mode

Executing the eZ8 CPU's HALT instruction places the device into HALT mode, which powers down the CPU but leaves all other peripherals active. In HALT mode, the operating characteristics are:

- Primary oscillator is enabled and continues to operate.
- System clock is enabled and continues to operate.
- eZ8 CPU is stopped.
- Program counter (PC) stops incrementing.
- Watchdog Timer's internal RC oscillator continues to operate.
- If enabled, the Watchdog Timer continues to operate.
- All other on-chip peripherals continue to operate, if enabled.

The eZ8 CPU can be brought out of HALT mode by any of the following operations:

- Interrupt
- Watchdog Timer time-out (interrupt or reset)
- Power-On Reset
- Voltage Brownout reset
- External  $\overline{\text{RESET}}$  pin assertion

To minimize current in HALT mode, all GPIO pins that are configured as inputs must be driven to one of the supply rails ( $V_{CC}$  or GND).

## Peripheral-Level Power Control

In addition to the STOP and HALT modes, it is possible to disable each peripheral on each of the Z8 Encore! XP F082A Series devices. Disabling a given peripheral minimizes its power consumption.

## Power Control Register Definitions

The following sections define the Power Control registers.

### Power Control Register 0

Each bit of the following registers disables a peripheral block, either by gating its system clock input or by removing power from the block. The default state of the low-power

operational amplifier (LPO) is OFF. To use the LPO, clear the LPO bit, turning it ON. Clearing this bit might interfere with normal ADC measurements on ANA0 (the LPO output). This bit enables the amplifier even in STOP mode. If the amplifier is not required in STOP mode, disable it. Failure to perform this results in STOP mode currents greater than specified.

► **Note:** *This register is only reset during a POR sequence. Other system reset events do not affect it.*

**Table 12. Power Control Register 0 (PWRCTL0)**

BITS	7	6	5	4	3	2	1	0
FIELD	LPO	Reserved		VBO	TEMP	ADC	COMP	Reserved
RESET	1	0	0	0	0	0	0	0
R/W	R/W	R/W	R/W	R/W	R/W	R/W	R/W	R/W
ADDR	F80H							

LPO—Low-Power Operational Amplifier Disable  
0 = LPO is enabled (this applies even in STOP mode).  
1 = LPO is disabled.

Reserved—Must be 0.

VBO—Voltage Brownout Detector Disable  
This bit and the VBO\_AO Flash option bit must both enable the VBO for the VBO to be active.  
0 = VBO Enabled  
1 = VBO Disabled

TEMP—Temperature Sensor Disable  
0 = Temperature Sensor Enabled  
1 = Temperature Sensor Disabled

ADC—Analog-to-Digital Converter Disable  
0 = Analog-to-Digital Converter Enabled  
1 = Analog-to-Digital Converter Disabled

COMP—Comparator Disable  
0 = Comparator is Enabled  
1 = Comparator is Disabled

Reserved—Must be 0.

► **Note:** *Asserting any power control bit disables the targeted block, regardless of any enable bits contained in the target block's control registers.*



# General-Purpose Input/Output

The Z8 Encore! XP<sup>®</sup> F082A Series products support a maximum of 25 port pins (Ports A–D) for general-purpose input/output (GPIO) operations. Each port contains control and data registers. The GPIO control registers determine data direction, open-drain, output drive current, programmable pull-ups, Stop Mode Recovery functionality, and alternate pin functions. Each port pin is individually programmable. In addition, the Port C pins are capable of direct LED drive at programmable drive strengths.

## GPIO Port Availability By Device

Table 13 lists the port pins available with each device and package type.

**Table 13. Port Availability by Device and Package Type**

Devices	Package	ADC	Port A	Port B	Port C	Port D	Total I/O
Z8F082ASB, Z8F082APB, Z8F082AQB Z8F042ASB, Z8F042APB, Z8F042AQB Z8F022ASB, Z8F022APB, Z8F022AQB Z8F012ASB, Z8F012APB, Z8F012AQB	8-pin	Yes	[5:0]	No	No	No	6
Z8F081ASB, Z8F081APB, Z8F081AQB Z8F041ASB, Z8F041APB, Z8F041AQB Z8F021ASB, Z8F021APB, Z8F021AQB Z8F011ASB, Z8F011APB, Z8F011AQB	8-pin	No	[5:0]	No	No	No	6
Z8F082APH, Z8F082AHH, Z8F082ASH Z8F042APH, Z8F042AHH, Z8F042ASH Z8F022APH, Z8F022AHH, Z8F022ASH Z8F012APH, Z8F012AHH, Z8F012ASH	20-pin	Yes	[7:0]	[3:0]	[3:0]	[0]	17
Z8F081APH, Z8F081AHH, Z8F081ASH Z8F041APH, Z8F041AHH, Z8F041ASH Z8F021APH, Z8F021AHH, Z8F021ASH Z8F011APH, Z8F011AHH, Z8F011ASH	20-pin	No	[7:0]	[3:0]	[3:0]	[0]	17
Z8F082APJ, Z8F082ASJ, Z8F082AHJ Z8F042APJ, Z8F042ASJ, Z8F042AHJ Z8F022APJ, Z8F022ASJ, Z8F022AHJ Z8F012APJ, Z8F012ASJ, Z8F012AHJ	28-pin	Yes	[7:0]	[5:0]	[7:0]	[0]	23
Z8F081APJ, Z8F081ASJ, Z8F081AHJ Z8F041APJ, Z8F041ASJ, Z8F041AHJ Z8F021APJ, Z8F021ASJ, Z8F021AHJ Z8F011APJ, Z8F011ASJ, Z8F011AHJ	28-pin	No	[7:0]	[7:0]	[7:0]	[0]	25



## Architecture

Figure 7 displays a simplified block diagram of a GPIO port pin. In this figure, the ability to accommodate alternate functions and variable port current drive strength is not displayed.

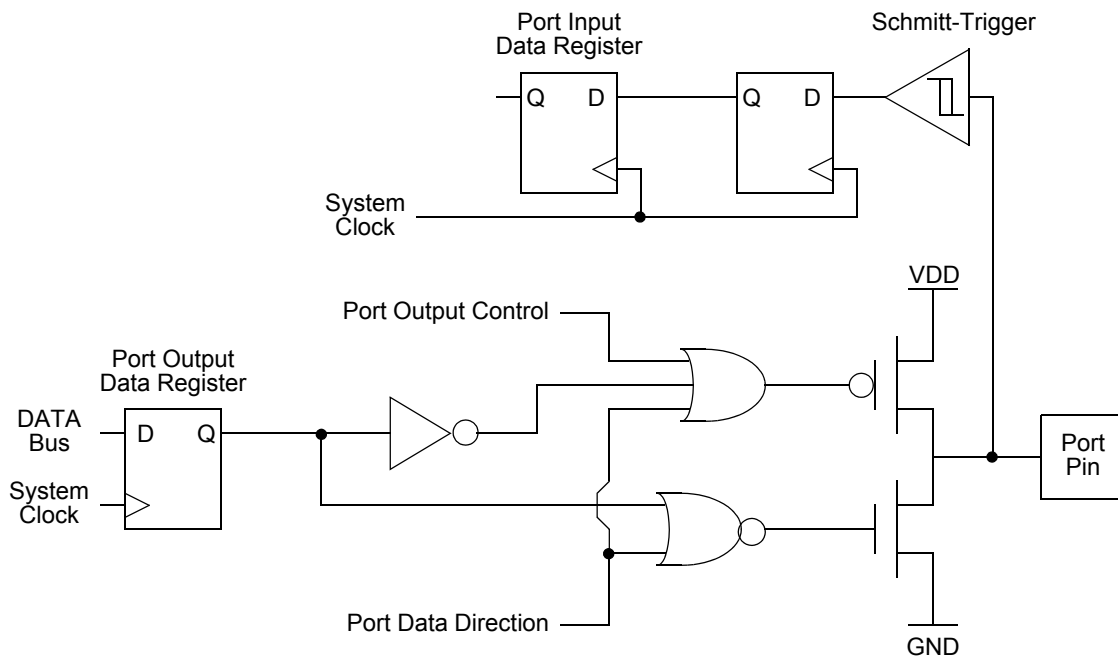

Figure 7. GPIO Port Pin Block Diagram

## GPIO Alternate Functions

Many of the GPIO port pins can be used for general-purpose I/O and access to on-chip peripheral functions such as the timers and serial communication devices. The Port A–D Alternate Function sub-registers configure these pins for either General-Purpose I/O or alternate function operation. When a pin is configured for alternate function, control of the port pin direction (input/output) is passed from the Port A–D Data Direction registers to the alternate function assigned to this pin. Table 14 on page 41 lists the alternate functions possible with each port pin. For those pins with more one alternate function, the alternate function is defined through Alternate Function Sets sub-registers AFS1 and AFS2.

The crystal oscillator functionality is not controlled by the GPIO block. When the crystal oscillator is enabled in the oscillator control block, the GPIO functionality of PA0 and PA1 is overridden. In that case, those pins function as input and output for the crystal oscillator.

PA0 and PA6 contain two different timer functions, a timer input and a complementary timer output. Both of these functions require the same GPIO configuration, the selection between the two is based on the timer mode. See [Timers](#) on page 69 for more details.



**Caution:** *For pin with multiple alternate functions, it is recommended to write to the AFS1 and AFS2 sub-registers before enabling the alternate function via the AF sub-register. This prevents spurious transitions through unwanted alternate function modes.*

## Direct LED Drive

The Port C pins provide a current sinked output capable of driving an LED without requiring an external resistor. The output sinks current at programmable levels of 3 mA, 7 mA, 13 mA and 20 mA. This mode is enabled through the Alternate Function sub-register AFS1 and is programmable through the LED control registers. The LED Drive Enable (LEDEN) register turns on the drivers. The LED Drive Level (LEDLVLH and LEDLVLL) registers select the sink current.

For correct function, the LED anode must be connected to  $V_{DD}$  and the cathode to the GPIO pin. Using all Port C pins in LED drive mode with maximum current may result in excessive total current. See [Electrical Characteristics](#) on page 221 for the maximum total current for the applicable package.

## Shared Reset Pin

On the 20- and 28-pin devices, the PD0 pin shares function with a bi-directional reset pin. Unlike all other I/O pins, this pin does not default to GPIO function on power-up. This pin acts as a bi-directional reset until the software re-configures it. The PD0 pin is output-only when in GPIO mode.

On the 8-pin product versions, the reset pin is shared with PA2, but the pin is not limited to output-only when in GPIO mode.



**Caution:** *If PA2 on the 8-pin product is reconfigured as an input, ensure that no external stimulus drives the pin low during any reset sequence. Since PA2 returns to its  $\overline{\text{RESET}}$  alternate function during system resets, driving it Low holds the chip in a reset state until the pin is released.*

## Shared Debug Pin

On the 8-pin version of this device only, the Debug pin shares function with the PA0 GPIO pin. This pin performs as a general purpose input pin on power-up, but the debug logic monitors this pin during the reset sequence to determine if the unlock sequence occurs. If the unlock sequence is present, the debug function is unlocked and the pin no longer func-

tions as a GPIO pin. If it is not present, the debug feature is disabled until/unless another reset event occurs. For more details, see [On-Chip Debugger](#) on page 173.

## Crystal Oscillator Override

For systems using a crystal oscillator, PA0 and PA1 are used to connect the crystal. When the crystal oscillator is enabled (see [Oscillator Control Register Definitions](#) on page 190), the GPIO settings are overridden and PA0 and PA1 are disabled.

## 5 V Tolerance

All six I/O pins on the 8-pin devices are 5 V-tolerant, unless the programmable pull-ups are enabled. If the pull-ups are enabled and inputs higher than  $V_{DD}$  are applied to these parts, excessive current flows through those pull-up devices and can damage the chip.

- **Note:** *In the 20- and 28-pin versions of this device, any pin which shares functionality with an ADC, crystal or comparator port is not 5 V-tolerant, including PA[1:0], PB[5:0] and PC[2:0]. All other signal pins are 5 V-tolerant, and can safely handle inputs higher than  $V_{DD}$  except when the programmable pull-ups are enabled.*

## External Clock Setup

For systems using an external TTL drive, PB3 is the clock source for 20- and 28-pin devices. In this case, configure PB3 for alternate function CLKIN. Write the Oscillator Control (OSCCTL) register (see [Oscillator Control Register Definitions](#) on page 190) such that the external oscillator is selected as the system clock. For 8-pin devices use PA1 instead of PB3.

**Table 14. Port Alternate Function Mapping (Non 8-Pin Parts)**

Port	Pin	Mnemonic	Alternate Function Description	Alternate Function Set Register AFS1
Port A	PA0	T0IN/T0OUT*	Timer 0 Input/Timer 0 Output Complement	N/A
		Reserved		
	PA1	T0OUT	Timer 0 Output	
		Reserved		
	PA2	DE0	UART 0 Driver Enable	
		Reserved		
	PA3	CTS0	UART 0 Clear to Send	
		Reserved		
	PA4	RXD0/IRRX0	UART 0/IrDA 0 Receive Data	
		Reserved		
	PA5	TXD0/IRTX0	UART 0/IrDA 0 Transmit Data	
		Reserved		
	PA6	T1IN/T1OUT*	Timer 1 Input/Timer 1 Output Complement	
		Reserved		
PA7	T1OUT	Timer 1 Output		
	Reserved			

**Note:** Because there is only a single alternate function for each Port A pin, the Alternate Function Set registers are not implemented for Port A. Enabling alternate function selections as described in [Port A–D Alternate Function Sub-Registers](#) on page 47 automatically enables the associated alternate function.

\* Whether PA0/PA6 take on the timer input or timer output complement function depends on the timer configuration as described in [Timer Pin Signal Operation](#) on page 82.

**Table 14. Port Alternate Function Mapping (Non 8-Pin Parts) (Continued)**

Port	Pin	Mnemonic	Alternate Function Description	Alternate Function Set Register AFS1
Port B	PB0	Reserved		AFS1[0]: 0
		ANA0/AMPOUT	ADC Analog Input/LPO Output	AFS1[0]: 1
	PB1	Reserved		AFS1[1]: 0
		ANA1/AMPINN	ADC Analog Input/LPO Input (N)	AFS1[1]: 1
	PB2	Reserved		AFS1[2]: 0
		ANA2/AMPINP	ADC Analog Input/LPO Input (P)	AFS1[2]: 1
	PB3	CLKIN	External Clock Input	AFS1[3]: 0
		ANA3	ADC Analog Input	AFS1[3]: 1
	PB4	Reserved		AFS1[4]: 0
		ANA7	ADC Analog Input	AFS1[4]: 1
	PB5	Reserved		AFS1[5]: 0
		VREF*	ADC Voltage Reference	AFS1[5]: 1
	PB6	Reserved		AFS1[6]: 0
		Reserved		AFS1[6]: 1
	PB7	Reserved		AFS1[7]: 0
		Reserved		AFS1[7]: 1

**Note:** Because there are at most two choices of alternate function for any pin of Port B, the Alternate Function Set register AFS2 is not used to select the function. Also, alternate function selection as described in [Port A–D Alternate Function Sub-Registers](#) on page 47 must also be enabled.

\* VREF is available on PB5 in 28-pin products only.

**Table 14. Port Alternate Function Mapping (Non 8-Pin Parts) (Continued)**

Port	Pin	Mnemonic	Alternate Function Description	Alternate Function Set Register AFS1
Port C	PC0	Reserved		AFS1[0]: 0
		ANA4/CINP/LED Drive	ADC or Comparator Input, or LED drive	AFS1[0]: 1
	PC1	Reserved		AFS1[1]: 0
		ANA5/CINN/LED Drive	ADC or Comparator Input, or LED drive	AFS1[1]: 1
	PC2	Reserved		AFS1[2]: 0
		ANA6/LED/VREF*	ADC Analog Input or LED Drive or ADC Voltage Reference	AFS1[2]: 1
	PC3	COUT	Comparator Output	AFS1[3]: 0
		LED	LED drive	AFS1[3]: 1
	PC4	Reserved		AFS1[4]: 0
		LED	LED Drive	AFS1[4]: 1
	PC5	Reserved		AFS1[5]: 0
		LED	LED Drive	AFS1[5]: 1
	PC6	Reserved		AFS1[6]: 0
		LED	LED Drive	AFS1[6]: 1
PC7	Reserved		AFS1[7]: 0	
	LED	LED Drive	AFS1[7]: 1	

**Note:** Because there are at most two choices of alternate function for any pin of Port C, the Alternate Function Set register AFS2 is not used to select the function. Also, alternate function selection as described in [Port A–D Alternate Function Sub-Registers](#) on page 47 must also be enabled.

\*VREF is available on PC2 in 20-pin parts only.

**Table 15. Port Alternate Function Mapping (8-Pin Parts)**

Port	Pin	Mnemonic	Alternate Function Description	Alternate Function Select Register AFS1	Alternate Function Select Register AFS2
Port A	PA0	T0IN	Timer 0 Input	AFS1[0]: 0	AFS2[0]: 0
		Reserved		AFS1[0]: 0	AFS2[0]: 1
		Reserved		AFS1[0]: 1	AFS2[0]: 0
		$\overline{T0OUT}$	Timer 0 Output Complement	AFS1[0]: 1	AFS2[0]: 1
	PA1	T0OUT	Timer 0 Output	AFS1[1]: 0	AFS2[1]: 0
		Reserved		AFS1[1]: 0	AFS2[1]: 1
		CLKIN	External Clock Input	AFS1[1]: 1	AFS2[1]: 0
		Analog Functions*	ADC Analog Input/VREF	AFS1[1]: 1	AFS2[1]: 1
	PA2	DE0	UART 0 Driver Enable	AFS1[2]: 0	AFS2[2]: 0
		$\overline{RESET}$	External Reset	AFS1[2]: 0	AFS2[2]: 1
		T1OUT	Timer 1 Output	AFS1[2]: 1	AFS2[2]: 0
		Reserved		AFS1[2]: 1	AFS2[2]: 1
	PA3	$\overline{CTS0}$	UART 0 Clear to Send	AFS1[3]: 0	AFS2[3]: 0
		COUT	Comparator Output	AFS1[3]: 0	AFS2[3]: 1
		T1IN	Timer 1 Input	AFS1[3]: 1	AFS2[3]: 0
		Analog Functions*	ADC Analog Input/LPO Input (P)	AFS1[3]: 1	AFS2[3]: 1
PA4	RXD0	UART 0 Receive Data	AFS1[4]: 0	AFS2[4]: 0	
	Reserved		AFS1[4]: 0	AFS2[4]: 1	
	Reserved		AFS1[4]: 1	AFS2[4]: 0	
	Analog Functions*	ADC/Comparator Input (N)/LPO Input (N)	AFS1[4]: 1	AFS2[4]: 1	
PA5	TXD0	UART 0 Transmit Data	AFS1[5]: 0	AFS2[5]: 0	
	$\overline{T1OUT}$	Timer 1 Output Complement	AFS1[5]: 0	AFS2[5]: 1	
	Reserved		AFS1[5]: 1	AFS2[5]: 0	
	Analog Functions*	ADC/Comparator Input (P) LPO Output	AFS1[5]: 1	AFS2[5]: 1	

\*Analog Functions include ADC inputs, ADC reference, comparator inputs and LPO ports.

**Note:** Also, alternate function selection as described in [Port A–D Alternate Function Sub-Registers](#) on page 47 must be enabled.

## GPIO Interrupts

Many of the GPIO port pins can be used as interrupt sources. Some port pins can be configured to generate an interrupt request on either the rising edge or falling edge of the pin input signal. Other port pin interrupt sources generate an interrupt when any edge occurs (both rising and falling). See [Interrupt Controller](#) on page 55 for more information about interrupts using the GPIO pins.

## GPIO Control Register Definitions

Four registers for each Port provide access to GPIO control, input data, and output data. [Table 16](#) lists these Port registers. Use the Port A–D Address and Control registers together to provide access to sub-registers for Port configuration and control.

**Table 16. GPIO Port Registers and Sub-Registers**

<b>Port Register Mnemonic</b>	<b>Port Register Name</b>
PxADDR	Port A–D Address Register (Selects sub-registers)
PxCTL	Port A–D Control Register (Provides access to sub-registers)
PxIN	Port A–D Input Data Register
PxOUT	Port A–D Output Data Register
<b>Port Sub-Register Mnemonic</b>	<b>Port Register Name</b>
PxDD	Data Direction
PxAF	Alternate Function
PxOC	Output Control (Open-Drain)
PxHDE	High Drive Enable
PxSMRE	Stop Mode Recovery Source Enable
PxPUE	Pull-up Enable
PxAFS1	Alternate Function Set 1
PxAFS2	Alternate Function Set 2



## Port A–D Address Registers

The Port A–D Address registers select the GPIO Port functionality accessible through the Port A–D Control registers. The Port A–D Address and Control registers combine to provide access to all GPIO Port controls ([Table 17](#)).

**Table 17. Port A–D GPIO Address Registers (PxADDR)**

BITS	7	6	5	4	3	2	1	0
FIELD	PADDR[7:0]							
RESET	00H							
R/W	R/W	R/W	R/W	R/W	R/W	R/W	R/W	R/W
ADDR	FD0H, FD4H, FD8H, FDCH							

PADDR[7:0]—Port Address

The Port Address selects one of the sub-registers accessible through the Port Control register.

### **PADDR[7:0] Port Control sub-register accessible using the Port A–D Control Registers**

00H	No function. Provides some protection against accidental Port reconfiguration.
01H	Data Direction.
02H	Alternate Function.
03H	Output Control (Open-Drain).
04H	High Drive Enable.
05H	Stop Mode Recovery Source Enable.
06H	Pull-up Enable.
07H	Alternate Function Set 1.
08H	Alternate Function Set 2.
09H–FFH	No function.

## Port A–D Control Registers

The Port A–D Control registers set the GPIO port operation. The value in the corresponding Port A–D Address register determines which sub-register is read from or written to by a Port A–D Control register transaction ([Table 18](#)).

**Table 18. Port A–D Control Registers (PxCTL)**

BITS	7	6	5	4	3	2	1	0
FIELD	PCTL							
RESET	00H							
R/W	R/W	R/W	R/W	R/W	R/W	R/W	R/W	R/W
ADDR	FD1H, FD5H, FD9H, FDDH							

PCTL[7:0]—Port Control

The Port Control register provides access to all sub-registers that configure the GPIO Port operation.

### Port A–D Data Direction Sub-Registers

The Port A–D Data Direction sub-register is accessed through the Port A–D Control register by writing 01H to the Port A–D Address register ([Table 19](#)).

**Table 19. Port A–D Data Direction Sub-Registers (PxDD)**

BITS	7	6	5	4	3	2	1	0
FIELD	DD7	DD6	DD5	DD4	DD3	DD2	DD1	DD0
RESET	1	1	1	1	1	1	1	1
R/W	R/W	R/W	R/W	R/W	R/W	R/W	R/W	R/W
ADDR	If 01H in Port A–D Address Register, accessible through the Port A–D Control Register							

DD[7:0]—Data Direction

These bits control the direction of the associated port pin. Port Alternate Function operation overrides the Data Direction register setting.

0 = Output. Data in the Port A–D Output Data register is driven onto the port pin.

1 = Input. The port pin is sampled and the value written into the Port A–D Input Data Register. The output driver is tristated.

### Port A–D Alternate Function Sub-Registers

The Port A–D Alternate Function sub-register ([Table 20](#)) is accessed through the Port A–D Control register by writing 02H to the Port A–D Address register. The Port A–D Alternate Function sub-registers enable the alternate function selection on pins. If disabled, pins functions as GPIO. If enabled, select one of four alternate functions using alternate function set subregisters 1 and 2 as described in the [Port A–D Alternate Function](#)

Set 1 Sub-Registers on page 50, GPIO Alternate Functions on page 38, and Port A–D Alternate Function Set 2 Sub-Registers on page 51. See GPIO Alternate Functions on page 38 to determine the alternate function associated with each port pin.



**Caution:** *Do not enable alternate functions for GPIO port pins for which there is no associated alternate function. Failure to follow this guideline can result in unpredictable operation.*

**Table 20. Port A–D Alternate Function Sub-Registers (PxAF)**

BITS	7	6	5	4	3	2	1	0
FIELD	AF7	AF6	AF5	AF4	AF3	AF2	AF1	AF0
RESET	00H (Ports A–C); 01H (Port D); 04H (Port A of 8-pin device)							
R/W	R/W							
ADDR	If 02H in Port A–D Address Register, accessible through the Port A–D Control Register							

AF[7:0]—Port Alternate Function enabled  
 0 = The port pin is in normal mode and the DDx bit in the Port A–D Data Direction sub-register determines the direction of the pin.  
 1 = The alternate function selected through Alternate Function Set sub-registers is enabled. Port pin operation is controlled by the alternate function.

### Port A–D Output Control Sub-Registers

The Port A–D Output Control sub-register (Table 21) is accessed through the Port A–D Control register by writing 03H to the Port A–D Address register. Setting the bits in the Port A–D Output Control sub-registers to 1 configures the specified port pins for open-drain operation. These sub-registers affect the pins directly and, as a result, alternate functions are also affected.

**Table 21. Port A–D Output Control Sub-Registers (PxOC)**

BITS	7	6	5	4	3	2	1	0
FIELD	POC7	POC6	POC5	POC4	POC3	POC2	POC1	POC0
RESET	00H (Ports A-C); 01H (Port D)							
R/W	R/W	R/W	R/W	R/W	R/W	R/W	R/W	R/W
ADDR	If 03H in Port A–D Address Register, accessible through the Port A–D Control Register							

POC[7:0]—Port Output Control  
 These bits function independently of the alternate function bit and always disable the drains if set to 1.  
 0 = The source current is enabled for any output mode (unless overridden by the alternate

function). (Push-pull output)

1 = The source current for the associated pin is disabled (open-drain mode).

### Port A–D High Drive Enable Sub-Registers

The Port A–D High Drive Enable sub-register (Table 22) is accessed through the Port A–D Control register by writing 04H to the Port A–D Address register. Setting the bits in the Port A–D High Drive Enable sub-registers to 1 configures the specified port pins for high current output drive operation. The Port A–D High Drive Enable sub-register affects the pins directly and, as a result, alternate functions are also affected.

**Table 22. Port A–D High Drive Enable Sub-Registers (PxHDE)**

BITS	7	6	5	4	3	2	1	0
FIELD	PHDE7	PHDE6	PHDE5	PHDE4	PHDE3	PHDE2	PHDE1	PHDE0
RESET	0	0	0	0	0	0	0	0
R/W	R/W	R/W	R/W	R/W	R/W	R/W	R/W	R/W
ADDR	If 04H in Port A–D Address Register, accessible through the Port A–D Control Register							

PHDE[7:0]—Port High Drive Enabled

0 = The Port pin is configured for standard output current drive.

1 = The Port pin is configured for high output current drive.

### Port A–D Stop Mode Recovery Source Enable Sub-Registers

The Port A–D Stop Mode Recovery Source Enable sub-register (Table 23) is accessed through the Port A–D Control register by writing 05H to the Port A–D Address register. Setting the bits in the Port A–D Stop Mode Recovery Source Enable sub-registers to 1 configures the specified Port pins as a Stop Mode Recovery source. During STOP mode, any logic transition on a Port pin enabled as a Stop Mode Recovery source initiates Stop Mode Recovery.

**Table 23. Port A–D Stop Mode Recovery Source Enable Sub-Registers (PxSMRE)**

BITS	7	6	5	4	3	2	1	0
FIELD	PSMRE7	PSMRE6	PSMRE5	PSMRE4	PSMRE3	PSMRE2	PSMRE1	PSMRE0
RESET	0	0	0	0	0	0	0	0
R/W	R/W	R/W	R/W	R/W	R/W	R/W	R/W	R/W
ADDR	If 05H in Port A–D Address Register, accessible through the Port A–D Control Register							

PSMRE[7:0]—Port Stop Mode Recovery Source Enabled

0 = The Port pin is not configured as a Stop Mode Recovery source. Transitions on this pin

during STOP mode do not initiate Stop Mode Recovery.

1 = The Port pin is configured as a Stop Mode Recovery source. Any logic transition on this pin during STOP mode initiates Stop Mode Recovery.

### Port A–D Pull-up Enable Sub-Registers

The Port A–D Pull-up Enable sub-register (Table 24) is accessed through the Port A–D Control register by writing 06H to the Port A–D Address register. Setting the bits in the Port A–D Pull-up Enable sub-registers enables a weak internal resistive pull-up on the specified Port pins.

**Table 24. Port A–D Pull-Up Enable Sub-Registers (PxPUE)**

BITS	7	6	5	4	3	2	1	0
FIELD	PPUE7	PPUE6	PPUE5	PPUE4	PPUE3	PPUE2	PPUE1	PPUE0
RESET	00H (Ports A-C); 01H (Port D); 04H (Port A of 8-pin device)							
R/W	R/W	R/W	R/W	R/W	R/W	R/W	R/W	R/W
ADDR	If 06H in Port A–D Address Register, accessible through the Port A–D Control Register							

PPUE[7:0]—Port Pull-up Enabled

0 = The weak pull-up on the Port pin is disabled.

1 = The weak pull-up on the Port pin is enabled.

### Port A–D Alternate Function Set 1 Sub-Registers

The Port A–D Alternate Function Set1 sub-register (Table 25) is accessed through the Port A–D Control register by writing 07H to the Port A–D Address register. The Alternate Function Set 1 sub-registers selects the alternate function available at a port pin. Alternate Functions selected by setting or clearing bits of this register are defined in [GPIO Alternate Functions](#) on page 38.

► **Note:** *Alternate function selection on port pins must also be enabled as described in [Port A–D Alternate Function Sub-Registers](#) on page 47.*

**Table 25. Port A–D Alternate Function Set 1 Sub-Registers (PxAFS1)**

BITS	7	6	5	4	3	2	1	0
FIELD	PAFS17	PAFS16	PAFS15	PAFS14	PAFS13	PAFS12	PAFS11	PAFS10
RESET	0	0	0	0	0	0	0	0
R/W	R/W	R/W	R/W	R/W	R/W	R/W	R/W	R/W
ADDR	If 07H in Port A–D Address Register, accessible through the Port A–D Control Register							

PAFS1[7:0]—Port Alternate Function Set 1

0 = Port Alternate Function selected as defined in [Table 14](#) and [Table 15](#) on page 44.

1 = Port Alternate Function selected as defined in [Table 14](#) and [Table 15](#) on page 44.

### Port A–D Alternate Function Set 2 Sub-Registers

The Port A–D Alternate Function Set 2 sub-register ([Table 26](#)) is accessed through the Port A–D Control register by writing 08H to the Port A–D Address register. The Alternate Function Set 2 sub-registers selects the alternate function available at a port pin. Alternate Functions selected by setting or clearing bits of this register is defined in [Table 15](#).

► **Note:** *Alternate function selection on port pins must also be enabled as described in [Port A–D Alternate Function Sub-Registers](#) on page 47.*

**Table 26. Port A–D Alternate Function Set 2 Sub-Registers (PxAFS2)**

BITS	7	6	5	4	3	2	1	0
FIELD	PAFS27	PAFS26	PAFS25	PAFS24	PAFS23	PAFS22	PAFS21	PAFS20
RESET	00H (all ports of 20/28 pin devices); 04H (Port A of 8-pin device)							
R/W	R/W	R/W	R/W	R/W	R/W	R/W	R/W	R/W
ADDR	If 08H in Port A–D Address Register, accessible through the Port A–D Control Register							

PAFS2[7:0]—Port Alternate Function Set 2

0 = Port Alternate Function selected as defined in [Table 15](#).

1 = Port Alternate Function selected as defined in [Table 15](#).

### Port A–C Input Data Registers

Reading from the Port A–C Input Data registers ([Table 27](#)) returns the sampled values from the corresponding port pins. The Port A–C Input Data registers are read-only. The value returned for any unused ports is 0. Unused ports include those missing on the 8- and 28-pin packages, as well as those missing on the ADC-enabled 28-pin packages.

**Table 27. Port A–C Input Data Registers (PxIN)**

BITS	7	6	5	4	3	2	1	0
FIELD	PIN7	PIN6	PIN5	PIN4	PIN3	PIN2	PIN1	PIN0
RESET	X	X	X	X	X	X	X	X
R/W	R	R	R	R	R	R	R	R
ADDR	FD2H, FD6H, FDAH							
X = Undefined.								

PIN[7:0]—Port Input Data  
Sampled data from the corresponding port pin input.  
0 = Input data is logical 0 (Low).  
1 = Input data is logical 1 (High).

## Port A–D Output Data Register

The Port A–D Output Data register (Table 28) controls the output data to the pins.

**Table 28. Port A–D Output Data Register (PxOUT)**

BITS	7	6	5	4	3	2	1	0
FIELD	POUT7	POUT6	POUT5	POUT4	POUT3	POUT2	POUT1	POUT0
RESET	0	0	0	0	0	0	0	0
R/W	R/W	R/W	R/W	R/W	R/W	R/W	R/W	R/W
ADDR	FD3H, FD7H, FDBH, FDFH							

POUT[7:0]—Port Output Data  
These bits contain the data to be driven to the port pins. The values are only driven if the corresponding pin is configured as an output and the pin is not configured for alternate function operation.  
0 = Drive a logical 0 (Low).  
1 = Drive a logical 1 (High). High value is not driven if the drain has been disabled by setting the corresponding Port Output Control register bit to 1.

## LED Drive Enable Register

The LED Drive Enable register (Table 29) activates the controlled current drive. The Port C pin must first be enabled by setting the Alternate Function register to select the LED function.

**Table 29. LED Drive Enable (LEDEN)**

BITS	7	6	5	4	3	2	1	0
FIELD	LEDEN[7:0]							
RESET	0	0	0	0	0	0	0	0
R/W	R/W	R/W	R/W	R/W	R/W	R/W	R/W	R/W
ADDR	F82H							

LEDEN[7:0]—LED Drive Enable

These bits determine which Port C pins are connected to an internal current sink.

0 = Tristate the Port C pin.

1 = Enable controlled current sink on the Port C pin.

### LED Drive Level High Register

The LED Drive Level registers contain two control bits for each Port C pin (Table 30).

These two bits select between four programmable drive levels. Each pin is individually programmable.

**Table 30. LED Drive Level High Register (LEDLVLH)**

BITS	7	6	5	4	3	2	1	0
FIELD	LEDLVLH[7:0]							
RESET	0	0	0	0	0	0	0	0
R/W	R/W	R/W	R/W	R/W	R/W	R/W	R/W	R/W
ADDR	F83H							

LEDLVLH[7:0]—LED Level High Bit

{LEDLVLH, LEDLVLL} select one of four programmable current drive levels for each Port C pin.

00 = 3 mA

01 = 7 mA

10 = 13 mA

11 = 20 mA

### LED Drive Level Low Register

The LED Drive Level registers contain two control bits for each Port C pin (Table 31).

These two bits select between four programmable drive levels. Each pin is individually programmable.



**Table 31. LED Drive Level Low Register (LEDLVLL)**

BITS	7	6	5	4	3	2	1	0
FIELD	LEDLVLL[7:0]							
RESET	0	0	0	0	0	0	0	0
R/W	R/W	R/W	R/W	R/W	R/W	R/W	R/W	R/W
ADDR	F84H							

LEDLVLL[7:0]—LED Level Low Bit  
 {LEDLVLH, LEDLVLL} select one of four programmable current drive levels for each Port C pin.  
 00 = 3 mA  
 01 = 7 mA  
 10 = 13 mA  
 11 = 20 mA

# Interrupt Controller

The interrupt controller on the Z8 Encore! XP F082A Series products prioritizes the interrupt requests from the on-chip peripherals and the GPIO port pins. The features of interrupt controller include:

- 20 possible interrupt sources with 18 unique interrupt vectors:
  - Twelve GPIO port pin interrupt sources (two interrupt vectors are shared).
  - Eight on-chip peripheral interrupt sources (two interrupt vectors are shared).
- Flexible GPIO interrupts:
  - Eight selectable rising and falling edge GPIO interrupts.
  - Four dual-edge interrupts.
- Three levels of individually programmable interrupt priority.
- Watchdog Timer and LVD can be configured to generate an interrupt.
- Supports vectored as well as polled interrupts

Interrupt requests (IRQs) allow peripheral devices to suspend CPU operation in an orderly manner and force the CPU to start an interrupt service routine (ISR). Usually this interrupt service routine is involved with the exchange of data, status information, or control information between the CPU and the interrupting peripheral. When the service routine is completed, the CPU returns to the operation from which it was interrupted.

The eZ8 CPU supports both vectored and polled interrupt handling. For polled interrupts, the interrupt controller has no effect on operation. For more information on interrupt servicing by the eZ8 CPU, refer to *eZ8 CPU Core User Manual (UM0128)* available for download at [www.zilog.com](http://www.zilog.com).

## Interrupt Vector Listing

Table 32 on page 56 lists all of the interrupts available in order of priority. The interrupt vector is stored with the most-significant byte (MSB) at the even Program Memory address and the least-significant byte (LSB) at the following odd Program Memory address.

- **Note:** *Some port interrupts are not available on the 8- and 20-pin packages. The ADC interrupt is unavailable on devices not containing an ADC.*

**Table 32. Trap and Interrupt Vectors in Order of Priority**

Priority	Program Memory Vector Address	Interrupt or Trap Source
Highest	0002H	Reset (not an interrupt)
	0004H	Watchdog Timer (see <a href="#">Watchdog Timer</a> on page 91)
	003AH	Primary Oscillator Fail Trap (not an interrupt)
	003CH	Watchdog Oscillator Fail Trap (not an interrupt)
	0006H	Illegal Instruction Trap (not an interrupt)
	0008H	Reserved
	000AH	Timer 1
	000CH	Timer 0
	000EH	UART 0 receiver
	0010H	UART 0 transmitter
	0012H	Reserved
	0014H	Reserved
	0016H	ADC
	0018H	Port A Pin 7, selectable rising or falling input edge or LVD (see <a href="#">Reset, Stop Mode Recovery, and Low Voltage Detection</a> on page 23)
	001AH	Port A Pin 6, selectable rising or falling input edge or Comparator Output
	001CH	Port A Pin 5, selectable rising or falling input edge
	001EH	Port A Pin 4, selectable rising or falling input edge
	0020H	Port A Pin 3, selectable rising or falling input edge
	0022H	Port A Pin 2, selectable rising or falling input edge
	0024H	Port A Pin 1, selectable rising or falling input edge
	0026H	Port A Pin 0, selectable rising or falling input edge
	0028H	Reserved
	002AH	Reserved
	002CH	Reserved
	002EH	Reserved
	0030H	Port C Pin 3, both input edges
	0032H	Port C Pin 2, both input edges

**Table 32. Trap and Interrupt Vectors in Order of Priority (Continued)**

Priority	Program Memory Vector Address	Interrupt or Trap Source
	0034H	Port C Pin 1, both input edges
Lowest	0036H	Port C Pin 0, both input edges
	0038H	Reserved

## Architecture

Figure 8 displays the interrupt controller block diagram.

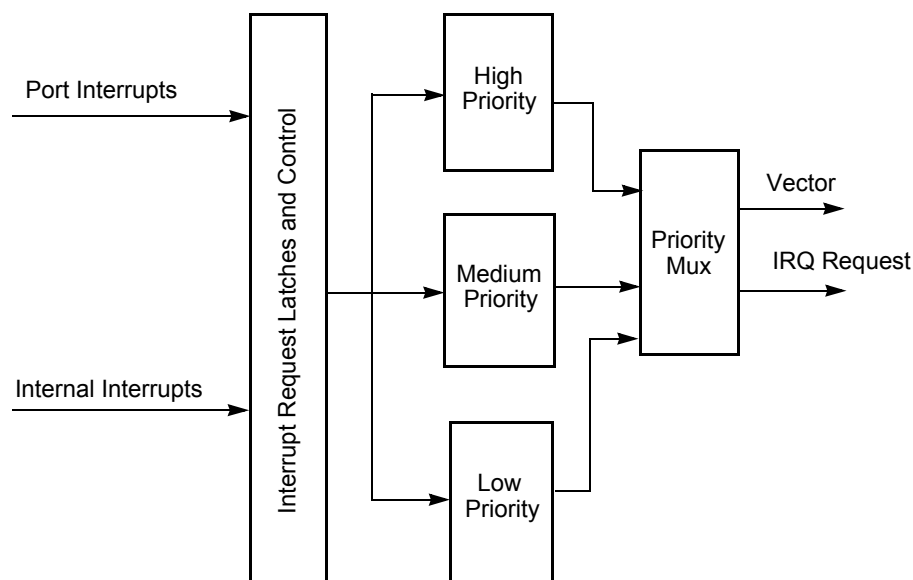

**Figure 8. Interrupt Controller Block Diagram**

## Operation

### Master Interrupt Enable

The master interrupt enable bit (IRQE) in the Interrupt Control register globally enables and disables interrupts.

Interrupts are globally enabled by any of the following actions:

- Execution of an EI (Enable Interrupt) instruction
- Execution of an IRET (Return from Interrupt) instruction
- Writing a 1 to the IRQE bit in the Interrupt Control register

Interrupts are globally disabled by any of the following actions:

- Execution of a DI (Disable Interrupt) instruction
- eZ8 CPU acknowledgement of an interrupt service request from the interrupt controller
- Writing a 0 to the IRQE bit in the Interrupt Control register
- Reset
- Execution of a Trap instruction
- Illegal Instruction Trap
- Primary Oscillator Fail Trap
- Watchdog Oscillator Fail Trap

## Interrupt Vectors and Priority

The interrupt controller supports three levels of interrupt priority. Level 3 is the highest priority, Level 2 is the second highest priority, and Level 1 is the lowest priority. If all of the interrupts are enabled with identical interrupt priority (all as Level 2 interrupts, for example), the interrupt priority is assigned from highest to lowest as specified in [Table 32](#) on page 56. Level 3 interrupts are always assigned higher priority than Level 2 interrupts which, in turn, always are assigned higher priority than Level 1 interrupts. Within each interrupt priority level (Level 1, Level 2, or Level 3), priority is assigned as specified in [Table 32](#), above. Reset, Watchdog Timer interrupt (if enabled), Primary Oscillator Fail Trap, Watchdog Oscillator Fail Trap, and Illegal Instruction Trap always have highest (level 3) priority.

## Interrupt Assertion

Interrupt sources assert their interrupt requests for only a single system clock period (single pulse). When the interrupt request is acknowledged by the eZ8 CPU, the corresponding bit in the Interrupt Request register is cleared until the next interrupt occurs. Writing a 0 to the corresponding bit in the Interrupt Request register likewise clears the interrupt request.



**Caution:** *The following coding style that clears bits in the Interrupt Request registers is not recommended. All incoming interrupts received between execution of the first LDX command and the final LDX command are lost.*

**Poor coding style that can result in lost interrupt requests:**

```
LDX r0, IRQ0
AND r0, MASK
LDX IRQ0, r0
```



**Caution:** *To avoid missing interrupts, use the following coding style to clear bits in the Interrupt Request 0 register:*

**Good coding style that avoids lost interrupt requests:**

```
ANDX IRQ0, MASK
```

## Software Interrupt Assertion

Program code can generate interrupts directly. Writing a 1 to the correct bit in the Interrupt Request register triggers an interrupt (assuming that interrupt is enabled). When the interrupt request is acknowledged by the eZ8 CPU, the bit in the Interrupt Request register is automatically cleared to 0.



**Caution:** *The following coding style used to generate software interrupts by setting bits in the Interrupt Request registers is not recommended. All incoming interrupts received between execution of the first LDX command and the final LDX command are lost.*

**Poor coding style that can result in lost interrupt requests:**

```
LDX r0, IRQ0
OR r0, MASK
LDX IRQ0, r0
```



**Caution:** *To avoid missing interrupts, use the following coding style to set bits in the Interrupt Request registers:*

**Good coding style that avoids lost interrupt requests:**

```
ORX IRQ0, MASK
```

## Watchdog Timer Interrupt Assertion

The Watchdog Timer interrupt behavior is different from interrupts generated by other sources. The Watchdog Timer continues to assert an interrupt as long as the timeout condition continues. As it operates on a different (and usually slower) clock domain than the rest of the device, the Watchdog Timer continues to assert this interrupt for many system clocks until the counter rolls over.



**Caution:** *To avoid re-triggerings of the Watchdog Timer interrupt after exiting the associated interrupt service routine, it is recommended that the service routine continues to read from the RSTSTAT register until the WDT bit is cleared as given in the following coding sample:*

```
CLEARWDT:
    LDX r0, RSTSTAT ; read reset status register to clear wdt bit
    BTJNZ 5, r0, CLEARWDT ; loop until bit is cleared
```

## Interrupt Control Register Definitions

For all interrupts other than the Watchdog Timer interrupt, the Primary Oscillator Fail Trap, and the Watchdog Oscillator Fail Trap, the interrupt control registers enable individual interrupts, set interrupt priorities, and indicate interrupt requests.

### Interrupt Request 0 Register

The Interrupt Request 0 (IRQ0) register (Table 33) stores the interrupt requests for both vectored and polled interrupts. When a request is presented to the interrupt controller, the corresponding bit in the IRQ0 register becomes 1. If interrupts are globally enabled (vectored interrupts), the interrupt controller passes an interrupt request to the eZ8 CPU. If interrupts are globally disabled (polled interrupts), the eZ8 CPU can read the Interrupt Request 0 register to determine if any interrupt requests are pending.

**Table 33. Interrupt Request 0 Register (IRQ0)**

BITS	7	6	5	4	3	2	1	0
FIELD	Reserved	T1I	T0I	U0RXI	U0TXI	Reserved	Reserved	ADCI
RESET	0	0	0	0	0	0	0	0
R/W	R/W	R/W	R/W	R/W	R/W	R/W	R/W	R/W
ADDR	FC0H							

Reserved—Must be 0.

T1I—Timer 1 Interrupt Request

0 = No interrupt request is pending for Timer 1.

1 = An interrupt request from Timer 1 is awaiting service.

T0I—Timer 0 Interrupt Request

0 = No interrupt request is pending for Timer 0.

1 = An interrupt request from Timer 0 is awaiting service.

U0RXI—UART 0 Receiver Interrupt Request

0 = No interrupt request is pending for the UART 0 receiver.

1 = An interrupt request from the UART 0 receiver is awaiting service.

U0TXI—UART 0 Transmitter Interrupt Request

0 = No interrupt request is pending for the UART 0 transmitter.

1 = An interrupt request from the UART 0 transmitter is awaiting service.

ADCI—ADC Interrupt Request

0 = No interrupt request is pending for the analog-to-digital Converter.

1 = An interrupt request from the Analog-to-Digital Converter is awaiting service.

## Interrupt Request 1 Register

The Interrupt Request 1 (IRQ1) register (Table 34) stores interrupt requests for both vectored and polled interrupts. When a request is presented to the interrupt controller, the corresponding bit in the IRQ1 register becomes 1. If interrupts are globally enabled (vectored interrupts), the interrupt controller passes an interrupt request to the eZ8 CPU. If interrupts are globally disabled (polled interrupts), the eZ8 CPU can read the Interrupt Request 1 register to determine if any interrupt requests are pending.

**Table 34. Interrupt Request 1 Register (IRQ1)**

BITS	7	6	5	4	3	2	1	0
FIELD	PA7VI	PA6CI	PA5I	PA4I	PA3I	PA2I	PA1I	PA0I
RESET	0	0	0	0	0	0	0	0
R/W	R/W	R/W	R/W	R/W	R/W	R/W	R/W	R/W
ADDR	FC3H							

PA7VI—Port A Pin 7 or LVD Interrupt Request

0 = No interrupt request is pending for GPIO Port A or LVD.

1 = An interrupt request from GPIO Port A or LVD.

PA6CI—Port A Pin 6 or Comparator Interrupt Request

0 = No interrupt request is pending for GPIO Port A or Comparator.

1 = An interrupt request from GPIO Port A or Comparator.

PAxI—Port A Pin x Interrupt Request

0 = No interrupt request is pending for GPIO Port A pin x.

1 = An interrupt request from GPIO Port A pin x is awaiting service.

where x indicates the specific GPIO Port pin number (0–5).



## Interrupt Request 2 Register

The Interrupt Request 2 (IRQ2) register (Table 35) stores interrupt requests for both vectored and polled interrupts. When a request is presented to the interrupt controller, the corresponding bit in the IRQ2 register becomes 1. If interrupts are globally enabled (vectored interrupts), the interrupt controller passes an interrupt request to the eZ8 CPU. If interrupts are globally disabled (polled interrupts), the eZ8 CPU can read the Interrupt Request 2 register to determine if any interrupt requests are pending.

**Table 35. Interrupt Request 2 Register (IRQ2)**

BITS	7	6	5	4	3	2	1	0
FIELD	Reserved				PC3I	PC2I	PC1I	PC0I
RESET	0	0	0	0	0	0	0	0
R/W	R/W	R/W	R/W	R/W	R/W	R/W	R/W	R/W
ADDR	FC6H							

Reserved—Must be 0.

PCxI—Port C Pin *x* Interrupt Request

0 = No interrupt request is pending for GPIO Port C pin *x*.

1 = An interrupt request from GPIO Port C pin *x* is awaiting service.

where *x* indicates the specific GPIO Port C pin number (0–3).

## IRQ0 Enable High and Low Bit Registers

Table 36 describes the priority control for IRQ0. The IRQ0 Enable High and Low Bit registers (Table 37 and Table 38) form a priority encoded enabling for interrupts in the Interrupt Request 0 register.

**Table 36. IRQ0 Enable and Priority Encoding**

IRQ0ENH[x]	IRQ0ENL[x]	Priority	Description
0	0	Disabled	Disabled
0	1	Level 1	Low
1	0	Level 2	Medium
1	1	Level 3	High

where *x* indicates the register bits from 0–7.

**Table 37. IRQ0 Enable High Bit Register (IRQ0ENH)**

BITS	7	6	5	4	3	2	1	0
FIELD	Reserved	T1ENH	T0ENH	U0RENH	U0TENH	Reserved	Reserved	ADCENH
RESET	0	0	0	0	0	0	0	0
R/W	R/W	R/W	R/W	R/W	R/W	R/W	R/W	R/W
ADDR	FC1H							

Reserved—Must be 0.

T1ENH—Timer 1 Interrupt Request Enable High Bit

T0ENH—Timer 0 Interrupt Request Enable High Bit

U0RENH—UART 0 Receive Interrupt Request Enable High Bit

U0TENH—UART 0 Transmit Interrupt Request Enable High Bit

ADCENH—ADC Interrupt Request Enable High Bit

**Table 38. IRQ0 Enable Low Bit Register (IRQ0ENL)**

BITS	7	6	5	4	3	2	1	0
FIELD	Reserved	T1ENL	T0ENL	U0RENL	U0TENL	Reserved	Reserved	ADCENL
RESET	0	0	0	0	0	0	0	0
R/W	R	R/W	R/W	R/W	R/W	R	R	R/W
ADDR	FC2H							

Reserved—Must be 0.

T1ENL—Timer 1 Interrupt Request Enable Low Bit

T0ENL—Timer 0 Interrupt Request Enable Low Bit

U0RENL—UART 0 Receive Interrupt Request Enable Low Bit

U0TENL—UART 0 Transmit Interrupt Request Enable Low Bit

ADCENL—ADC Interrupt Request Enable Low Bit

## IRQ1 Enable High and Low Bit Registers

Table 39 describes the priority control for IRQ1. The IRQ1 Enable High and Low Bit registers (Table 40 and Table 41) form a priority encoded enabling for interrupts in the Interrupt Request 1 register.

**Table 39. IRQ1 Enable and Priority Encoding**

IRQ1ENH[x]	IRQ1ENL[x]	Priority	Description
0	0	Disabled	Disabled
0	1	Level 1	Low
1	0	Level 2	Medium
1	1	Level 3	High

where x indicates the register bits from 0–7.

**Table 40. IRQ1 Enable High Bit Register (IRQ1ENH)**

BITS	7	6	5	4	3	2	1	0
FIELD	PA7VENH	PA6CENH	PA5ENH	PA4ENH	PA3ENH	PA2ENH	PA1ENH	PA0ENH
RESET	0	0	0	0	0	0	0	0
R/W	R/W	R/W	R/W	R/W	R/W	R/W	R/W	R/W
ADDR	FC4H							

PA7VENH—Port A Bit[7] or LVD Interrupt Request Enable High Bit

PA6CENH—Port A Bit[7] or Comparator Interrupt Request Enable High Bit

PAxENH—Port A Bit[x] Interrupt Request Enable High Bit

See Shared Interrupt Select (IRQSS) register for selection of either the LVD or the comparator as the interrupt source.

**Table 41. IRQ1 Enable Low Bit Register (IRQ1ENL)**

BITS	7	6	5	4	3	2	1	0
FIELD	PA7VENL	PA6CENL	PA5ENL	PA4ENL	PA3ENL	PA2ENL	PA1ENL	PA0ENL
RESET	0	0	0	0	0	0	0	0
R/W	R/W	R/W	R/W	R/W	R/W	R/W	R/W	R/W
ADDR	FC5H							

PA7VENL—Port A Bit[7] or LVD Interrupt Request Enable Low Bit

PA6CENL—Port A Bit[6] or Comparator Interrupt Request Enable Low Bit

PAxENL—Port A Bit[x] Interrupt Request Enable Low Bit

## IRQ2 Enable High and Low Bit Registers

Table 42 describes the priority control for IRQ2. The IRQ2 Enable High and Low Bit registers (Table 43 and Table 44) form a priority encoded enabling for interrupts in the Interrupt Request 2 register.

**Table 42. IRQ2 Enable and Priority Encoding**

IRQ2ENH[x]	IRQ2ENL[x]	Priority	Description
0	0	Disabled	Disabled
0	1	Level 1	Low
1	0	Level 2	Medium
1	1	Level 3	High

where x indicates the register bits from 0–7.

**Table 43. IRQ2 Enable High Bit Register (IRQ2ENH)**

BITS	7	6	5	4	3	2	1	0
FIELD	Reserved				C3ENH	C2ENH	C1ENH	C0ENH
RESET	0	0	0	0	0	0	0	0
R/W	R/W	R/W	R/W	R/W	R/W	R/W	R/W	R/W
ADDR	FC7H							

Reserved—Must be 0.

C3ENH—Port C3 Interrupt Request Enable High Bit

C2ENH—Port C2 Interrupt Request Enable High Bit

C1ENH—Port C1 Interrupt Request Enable High Bit

C0ENH—Port C0 Interrupt Request Enable High Bit

**Table 44. IRQ2 Enable Low Bit Register (IRQ2ENL)**

BITS	7	6	5	4	3	2	1	0
FIELD	Reserved				C3ENL	C2ENL	C1ENL	C0ENL
RESET	0	0	0	0	0	0	0	0
R/W	R/W	R/W	R/W	R/W	R/W	R/W	R/W	R/W
ADDR	FC8H							

Reserved—Must be 0.

- C3ENL—Port C3 Interrupt Request Enable Low Bit
- C2ENL—Port C2 Interrupt Request Enable Low Bit
- C1ENL—Port C1 Interrupt Request Enable Low Bit
- C0ENL—Port C0 Interrupt Request Enable Low Bit

### Interrupt Edge Select Register

The Interrupt Edge Select (IRQES) register (Table 45) determines whether an interrupt is generated for the rising edge or falling edge on the selected GPIO Port A input pin.

**Table 45. Interrupt Edge Select Register (IRQES)**

BITS	7	6	5	4	3	2	1	0
FIELD	IES7	IES6	IES5	IES4	IES3	IES2	IES1	IES0
RESET	0	0	0	0	0	0	0	0
R/W	R/W	R/W	R/W	R/W	R/W	R/W	R/W	R/W
ADDR	FCDH							

IES<sub>x</sub>—Interrupt Edge Select *x*

0 = An interrupt request is generated on the falling edge of the PA<sub>x</sub> input.

1 = An interrupt request is generated on the rising edge of the PA<sub>x</sub> input.

where *x* indicates the specific GPIO Port pin number (0 through 7).

### Shared Interrupt Select Register

The Shared Interrupt Select (IRQSS) register (Table 46) determines the source of the PAD<sub>x</sub>S interrupts. The Shared Interrupt Select register selects between Port A and alternate sources for the individual interrupts.

Because these shared interrupts are edge-triggered, it is possible to generate an interrupt just by switching from one shared source to another. For this reason, an interrupt must be disabled before switching between sources.

**Table 46. Shared Interrupt Select Register (IRQSS)**

BITS	7	6	5	4	3	2	1	0
FIELD	PA7VS	PA6CS	Reserved					
RESET	0	0	0	0	0	0	0	0
R/W	R/W	R/W	R/W	R/W	R/W	R/W	R/W	R/W
ADDR	FCEH							

PA7VS—PA7/LVD Selection

0 = PA7 is used for the interrupt for PA7VS interrupt request.

1 = The LVD is used for the interrupt for PA7VS interrupt request.

PA6CS—PA6/Comparator Selection

0 = PA6 is used for the interrupt for PA6CS interrupt request.

1 = The Comparator is used for the interrupt for PA6CS interrupt request.

Reserved—Must be 0.

## Interrupt Control Register

The Interrupt Control (IRQCTL) register ([Table 47](#)) contains the master enable bit for all interrupts.

**Table 47. Interrupt Control Register (IRQCTL)**

BITS	7	6	5	4	3	2	1	0
FIELD	IRQE	Reserved						
RESET	0	0	0	0	0	0	0	0
R/W	R/W	R	R	R	R	R	R	R
ADDR	FCFH							

IRQE—Interrupt Request Enable

This bit is set to 1 by executing an EI (Enable Interrupts) or IRET (Interrupt Return) instruction, or by a direct register write of a 1 to this bit. It is reset to 0 by executing a DI instruction, eZ8 CPU acknowledgement of an interrupt request, Reset or by a direct register write of a 0 to this bit.

0 = Interrupts are disabled.

1 = Interrupts are enabled.

Reserved—Must be 0.



# Timers

These Z8 Encore! XP® F082A Series products contain two 16-bit reloadable timers that can be used for timing, event counting, or generation of pulse-width modulated (PWM) signals. The timers' feature include:

- 16-bit reload counter.
- Programmable prescaler with prescale values from 1 to 128.
- PWM output generation.
- Capture and compare capability.
- External input pin for timer input, clock gating, or capture signal. External input pin signal frequency is limited to a maximum of one-fourth the system clock frequency.
- Timer output pin.
- Timer interrupt.

In addition to the timers described in this chapter, the Baud Rate Generator of the UART (if unused) may also provide basic timing functionality. For information on using the Baud Rate Generator as an additional timer, see [Universal Asynchronous Receiver/Transmitter](#) on page 97.

## Architecture

[Figure 9](#) on page 70 displays the architecture of the timers.



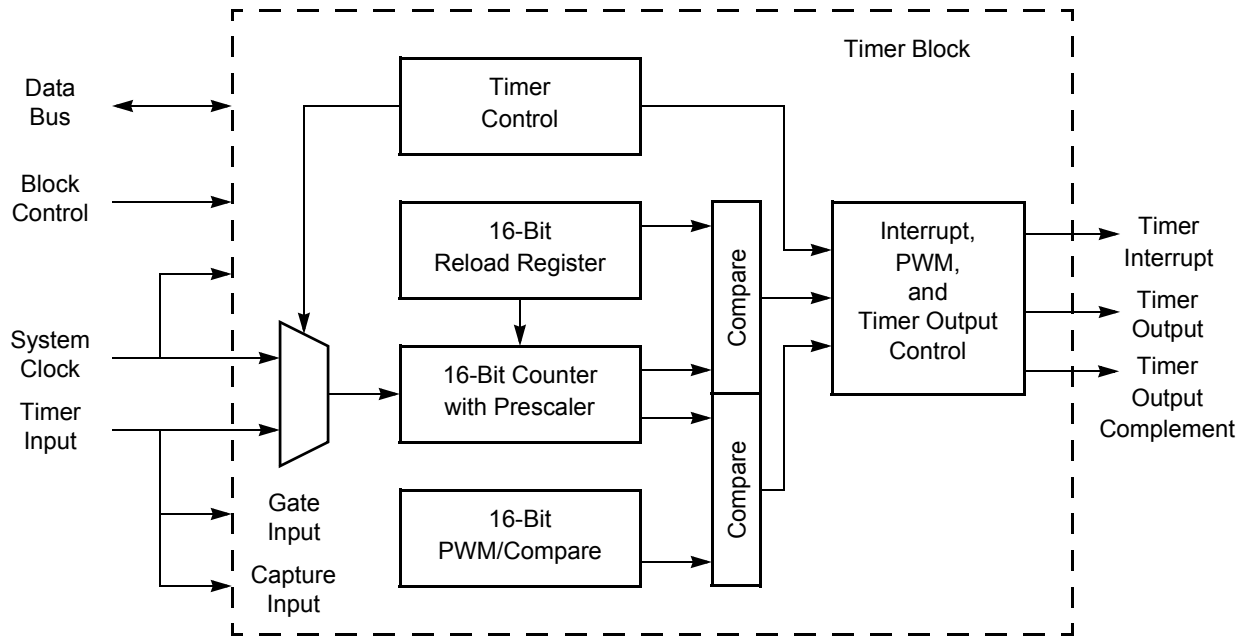

Figure 9. Timer Block Diagram

## Operation

The timers are 16-bit up-counters. Minimum time-out delay is set by loading the value 0001H into the Timer Reload High and Low Byte registers and setting the prescale value to 1. Maximum time-out delay is set by loading the value 0000H into the Timer Reload High and Low Byte registers and setting the prescale value to 128. If the Timer reaches FFFFH, the timer rolls over to 0000H and continues counting.

### Timer Operating Modes

The timers can be configured to operate in the following modes:

#### ONE-SHOT Mode

In ONE-SHOT mode, the timer counts up to the 16-bit Reload value stored in the Timer Reload High and Low byte registers. The timer input is the system clock. Upon reaching the Reload value, the timer generates an interrupt and the count value in the Timer High and Low Byte registers is reset to 0001H. The timer is automatically disabled and stops counting.

Also, if the Timer Output alternate function is enabled, the Timer Output pin changes state for one system clock cycle (from Low to High or from High to Low) upon timer Reload. If it is appropriate to have the Timer Output make a state change at a One-Shot time-out (rather than a single cycle pulse), first set the TPOL bit in the Timer Control Register to the start value before enabling ONE-SHOT mode. After starting the timer, set TPOL to the opposite bit value.

Follow the steps below for configuring a timer for ONE-SHOT mode and initiating the count:

1. Write to the Timer Control register to:
  - Disable the timer
  - Configure the timer for ONE-SHOT mode.
  - Set the prescale value.
  - Set the initial output level (High or Low) if using the Timer Output alternate function.
2. Write to the Timer High and Low Byte registers to set the starting count value.
3. Write to the Timer Reload High and Low Byte registers to set the Reload value.
4. If appropriate, enable the timer interrupt and set the timer interrupt priority by writing to the relevant interrupt registers.
5. If using the Timer Output function, configure the associated GPIO port pin for the Timer Output alternate function.
6. Write to the Timer Control register to enable the timer and initiate counting.

In ONE-SHOT mode, the system clock always provides the timer input. The timer period is given by the following equation:

$$\text{ONE-SHOT Mode Time-Out Period (s)} = \frac{\text{Reload Value} - \text{Start Value} \times \text{Prescale}}{\text{System Clock Frequency (Hz)}}$$

### CONTINUOUS Mode

In CONTINUOUS mode, the timer counts up to the 16-bit Reload value stored in the Timer Reload High and Low Byte registers. The timer input is the system clock. Upon reaching the Reload value, the timer generates an interrupt, the count value in the Timer High and Low Byte registers is reset to 0001H and counting resumes. Also, if the Timer Output alternate function is enabled, the Timer Output pin changes state (from Low to High or from High to Low) at timer Reload.

Follow the steps below for configuring a timer for CONTINUOUS mode and initiating the count:

1. Write to the Timer Control register to:
  - Disable the timer
  - Configure the timer for CONTINUOUS mode.

- Set the prescale value.
  - If using the Timer Output alternate function, set the initial output level (High or Low).
2. Write to the Timer High and Low Byte registers to set the starting count value (usually 0001H). This action only affects the first pass in CONTINUOUS mode. After the first timer Reload in CONTINUOUS mode, counting always begins at the reset value of 0001H.
  3. Write to the Timer Reload High and Low Byte registers to set the Reload value.
  4. Enable the timer interrupt (if appropriate) and set the timer interrupt priority by writing to the relevant interrupt registers.
  5. Configure the associated GPIO port pin (if using the Timer Output function) for the Timer Output alternate function.
  6. Write to the Timer Control register to enable the timer and initiate counting.

In CONTINUOUS mode, the system clock always provides the timer input. The timer period is given by the following equation:

$$\text{CONTINUOUS Mode Time-Out Period (s)} = \frac{\text{Reload Value} \times \text{Prescale}}{\text{System Clock Frequency (Hz)}}$$

If an initial starting value other than 0001H is loaded into the Timer High and Low Byte registers, use the ONE-SHOT mode equation to determine the first time-out period.

### COUNTER Mode

In COUNTER mode, the timer counts input transitions from a GPIO port pin. The timer input is taken from the GPIO Port pin Timer Input alternate function. The TPOL bit in the Timer Control Register selects whether the count occurs on the rising edge or the falling edge of the Timer Input signal. In COUNTER mode, the prescaler is disabled.



**Caution:** *The input frequency of the Timer Input signal must not exceed one-fourth the system clock frequency. Further, the high or low state of the input signal pulse must be no less than twice the system clock period. A shorter pulse may not be captured.*

Upon reaching the Reload value stored in the Timer Reload High and Low Byte registers, the timer generates an interrupt, the count value in the Timer High and Low Byte registers is reset to 0001H and counting resumes. Also, if the Timer Output alternate function is enabled, the Timer Output pin changes state (from Low to High or from High to Low) at timer Reload.

Follow the steps below for configuring a timer for COUNTER mode and initiating the count:

1. Write to the Timer Control register to:
  - Disable the timer.
  - Configure the timer for COUNTER mode.
  - Select either the rising edge or falling edge of the Timer Input signal for the count. This selection also sets the initial logic level (High or Low) for the Timer Output alternate function. However, the Timer Output function is not required to be enabled.
2. Write to the Timer High and Low Byte registers to set the starting count value. This only affects the first pass in COUNTER mode. After the first timer Reload in COUNTER mode, counting always begins at the reset value of 0001H. In COUNTER mode the Timer High and Low Byte registers must be written with the value 0001H.
3. Write to the Timer Reload High and Low Byte registers to set the Reload value.
4. If appropriate, enable the timer interrupt and set the timer interrupt priority by writing to the relevant interrupt registers.
5. Configure the associated GPIO port pin for the Timer Input alternate function.
6. If using the Timer Output function, configure the associated GPIO port pin for the Timer Output alternate function.
7. Write to the Timer Control register to enable the timer.

In COUNTER mode, the number of Timer Input transitions since the timer start is given by the following equation:

$$\text{COUNTER Mode Timer Input Transitions} = \text{Current Count Value} - \text{Start Value}$$

### COMPARATOR COUNTER Mode

In COMPARATOR COUNTER mode, the timer counts input transitions from the analog comparator output. The TPOL bit in the Timer Control Register selects whether the count occurs on the rising edge or the falling edge of the comparator output signal. In COMPARATOR COUNTER mode, the prescaler is disabled.



**Caution:** *The frequency of the comparator output signal must not exceed one-fourth the system clock frequency. Further, the high or low state of the comparator output signal pulse must be no less than twice the system clock period. A shorter pulse may not be captured.*

After reaching the Reload value stored in the Timer Reload High and Low Byte registers, the timer generates an interrupt, the count value in the Timer High and Low Byte registers is reset to 0001H and counting resumes. Also, if the Timer Output alternate function is enabled, the Timer Output pin changes state (from Low to High or from High to Low) at timer Reload.

Follow the steps below for configuring a timer for COMPARATOR COUNTER mode and initiating the count:

1. Write to the Timer Control register to:
  - Disable the timer.
  - Configure the timer for COMPARATOR COUNTER mode.
  - Select either the rising edge or falling edge of the comparator output signal for the count. This also sets the initial logic level (High or Low) for the Timer Output alternate function. However, the Timer Output function is not required to be enabled.
2. Write to the Timer High and Low Byte registers to set the starting count value. This action only affects the first pass in COMPARATOR COUNTER mode. After the first timer Reload in COMPARATOR COUNTER mode, counting always begins at the reset value of 0001H. Generally, in COMPARATOR COUNTER mode the Timer High and Low Byte registers must be written with the value 0001H.
3. Write to the Timer Reload High and Low Byte registers to set the Reload value.
4. If appropriate, enable the timer interrupt and set the timer interrupt priority by writing to the relevant interrupt registers.
5. If using the Timer Output function, configure the associated GPIO port pin for the Timer Output alternate function.
6. Write to the Timer Control register to enable the timer.

In COMPARATOR COUNTER mode, the number of comparator output transitions since the timer start is given by the following equation:

$$\text{Comparator Output Transitions} = \text{Current Count Value} - \text{Start Value}$$

### **PWM SINGLE OUTPUT Mode**

In PWM SINGLE OUTPUT mode, the timer outputs a Pulse-Width Modulator (PWM) output signal through a GPIO Port pin. The timer input is the system clock. The timer first counts up to the 16-bit PWM match value stored in the Timer PWM High and Low Byte registers. When the timer count value matches the PWM value, the Timer Output toggles. The timer continues counting until it reaches the Reload value stored in the Timer Reload High and Low Byte registers. Upon reaching the Reload value, the timer generates an interrupt, the count value in the Timer High and Low Byte registers is reset to 0001H and counting resumes.

If the TPOL bit in the Timer Control register is set to 1, the Timer Output signal begins as a High (1) and transitions to a Low (0) when the timer value matches the PWM value. The Timer Output signal returns to a High (1) after the timer reaches the Reload value and is reset to 0001H.

If the TPOL bit in the Timer Control register is set to 0, the Timer Output signal begins as a Low (0) and transitions to a High (1) when the timer value matches the PWM value. The Timer Output signal returns to a Low (0) after the timer reaches the Reload value and is reset to 0001H.

Follow the steps below for configuring a timer for PWM SINGLE OUTPUT mode and initiating the PWM operation:

1. Write to the Timer Control register to:
  - Disable the timer.
  - Configure the timer for PWM SINGLE OUTPUT mode.
  - Set the prescale value.
  - Set the initial logic level (High or Low) and PWM High/Low transition for the Timer Output alternate function.
2. Write to the Timer High and Low Byte registers to set the starting count value (typically 0001H). This only affects the first pass in PWM mode. After the first timer reset in PWM mode, counting always begins at the reset value of 0001H.
3. Write to the PWM High and Low Byte registers to set the PWM value.
4. Write to the Timer Reload High and Low Byte registers to set the Reload value (PWM period). The Reload value must be greater than the PWM value.
5. If appropriate, enable the timer interrupt and set the timer interrupt priority by writing to the relevant interrupt registers.
6. Configure the associated GPIO port pin for the Timer Output alternate function.
7. Write to the Timer Control register to enable the timer and initiate counting.

The PWM period is represented by the following equation:

$$\text{PWM Period (s)} = \frac{\text{Reload Value} \times \text{Prescale}}{\text{System Clock Frequency (Hz)}}$$

If an initial starting value other than 0001H is loaded into the Timer High and Low Byte registers, use the ONE-SHOT mode equation to determine the first PWM time-out period.

If TPOL is set to 0, the ratio of the PWM output High time to the total period is represented by:

$$\text{PWM Output High Time Ratio (\%)} = \frac{\text{Reload Value} - \text{PWM Value}}{\text{Reload Value}} \times 100$$

If TPOL is set to 1, the ratio of the PWM output High time to the total period is represented by:

$$\text{PWM Output High Time Ratio (\%)} = \frac{\text{PWM Value}}{\text{Reload Value}} \times 100$$

## PWM DUAL OUTPUT Mode

In PWM DUAL OUTPUT mode, the timer outputs a Pulse-Width Modulated (PWM) output signal pair (basic PWM signal and its complement) through two GPIO Port pins. The timer input is the system clock. The timer first counts up to the 16-bit PWM match value stored in the Timer PWM High and Low Byte registers. When the timer count value matches the PWM value, the Timer Output toggles. The timer continues counting until it reaches the Reload value stored in the Timer Reload High and Low Byte registers. Upon reaching the Reload value, the timer generates an interrupt, the count value in the Timer High and Low Byte registers is reset to 0001H and counting resumes.

If the TPOL bit in the Timer Control register is set to 1, the Timer Output signal begins as a High (1) and transitions to a Low (0) when the timer value matches the PWM value. The Timer Output signal returns to a High (1) after the timer reaches the Reload value and is reset to 0001H.

If the TPOL bit in the Timer Control register is set to 0, the Timer Output signal begins as a Low (0) and transitions to a High (1) when the timer value matches the PWM value. The Timer Output signal returns to a Low (0) after the timer reaches the Reload value and is reset to 0001H.

The timer also generates a second PWM output signal Timer Output Complement. The Timer Output Complement is the complement of the Timer Output PWM signal. A programmable deadband delay can be configured to time delay (0 to 128 system clock cycles) PWM output transitions on these two pins from a low to a high (inactive to active). This ensures a time gap between the deassertion of one PWM output to the assertion of its complement.

Follow the steps below for configuring a timer for PWM DUAL OUTPUT mode and initiating the PWM operation:

1. Write to the Timer Control register to:
  - Disable the timer.
  - Configure the timer for PWM DUAL OUTPUT mode by writing the TMODE bits in the TxCTL1 register and the TMODEHI bit in TxCTL0 register.
  - Set the prescale value.
  - Set the initial logic level (High or Low) and PWM High/Low transition for the Timer Output alternate function.
2. Write to the Timer High and Low Byte registers to set the starting count value (typically 0001H). This only affects the first pass in PWM mode. After the first timer reset in PWM mode, counting always begins at the reset value of 0001H.
3. Write to the PWM High and Low Byte registers to set the PWM value.
4. Write to the PWM Control register to set the PWM dead band delay value. The deadband delay must be less than the duration of the positive phase of the PWM signal (as defined by the PWM high and low byte registers). It must also be less than the

duration of the negative phase of the PWM signal (as defined by the difference between the PWM registers and the Timer Reload registers).

5. Write to the Timer Reload High and Low Byte registers to set the Reload value (PWM period). The Reload value must be greater than the PWM value.
6. If appropriate, enable the timer interrupt and set the timer interrupt priority by writing to the relevant interrupt registers.
7. Configure the associated GPIO port pin for the Timer Output and Timer Output Complement alternate functions. The Timer Output Complement function is shared with the Timer Input function for both timers. Setting the timer mode to Dual PWM automatically switches the function from Timer In to Timer Out Complement.
8. Write to the Timer Control register to enable the timer and initiate counting.

The PWM period is represented by the following equation:

$$\text{PWM Period (s)} = \frac{\text{Reload Value} \times \text{Prescale}}{\text{System Clock Frequency (Hz)}}$$

If an initial starting value other than 0001H is loaded into the Timer High and Low Byte registers, the ONE-SHOT mode equation determines the first PWM time-out period.

If TPOL is set to 0, the ratio of the PWM output High time to the total period is represented by:

$$\text{PWM Output High Time Ratio (\%)} = \frac{\text{Reload Value} - \text{PWM Value}}{\text{Reload Value}} \times 100$$

If TPOL is set to 1, the ratio of the PWM output High time to the total period is represented by:

$$\text{PWM Output High Time Ratio (\%)} = \frac{\text{PWM Value}}{\text{Reload Value}} \times 100$$

### CAPTURE Mode

In CAPTURE mode, the current timer count value is recorded when the appropriate external Timer Input transition occurs. The Capture count value is written to the Timer PWM High and Low Byte Registers. The timer input is the system clock. The TPOL bit in the Timer Control register determines if the Capture occurs on a rising edge or a falling edge of the Timer Input signal. When the Capture event occurs, an interrupt is generated and the timer continues counting. The INPCAP bit in TxCTL0 register is set to indicate the timer interrupt is because of an input capture event.

The timer continues counting up to the 16-bit Reload value stored in the Timer Reload High and Low Byte registers. Upon reaching the Reload value, the timer generates an interrupt and continues counting. The INPCAP bit in TxCTL0 register clears indicating the timer interrupt is not because of an input capture event.



Follow the steps below for configuring a timer for CAPTURE mode and initiating the count:

1. Write to the Timer Control register to:
  - Disable the timer.
  - Configure the timer for CAPTURE mode.
  - Set the prescale value.
  - Set the Capture edge (rising or falling) for the Timer Input.
2. Write to the Timer High and Low Byte registers to set the starting count value (typically 0001H).
3. Write to the Timer Reload High and Low Byte registers to set the Reload value.
4. Clear the Timer PWM High and Low Byte registers to 0000H. Clearing these registers allows the software to determine if interrupts were generated by either a capture event or a reload. If the PWM High and Low Byte registers still contain 0000H after the interrupt, the interrupt was generated by a Reload.
5. Enable the timer interrupt, if appropriate, and set the timer interrupt priority by writing to the relevant interrupt registers. By default, the timer interrupt is generated for both input capture and reload events. If appropriate, configure the timer interrupt to be generated only at the input capture event or the reload event by setting TICONFIG field of the TxCTL0 register.
6. Configure the associated GPIO port pin for the Timer Input alternate function.
7. Write to the Timer Control register to enable the timer and initiate counting.

In CAPTURE mode, the elapsed time from timer start to Capture event can be calculated using the following equation:

$$\text{Capture Elapsed Time (s)} = \frac{(\text{Capture Value} - \text{Start Value}) \times \text{Prescale}}{\text{System Clock Frequency (Hz)}}$$

### **CAPTURE RESTART Mode**

In CAPTURE RESTART mode, the current timer count value is recorded when the acceptable external Timer Input transition occurs. The Capture count value is written to the Timer PWM High and Low Byte Registers. The timer input is the system clock. The TPOL bit in the Timer Control register determines if the Capture occurs on a rising edge or a falling edge of the Timer Input signal. When the Capture event occurs, an interrupt is generated and the count value in the Timer High and Low Byte registers is reset to 0001H and counting resumes. The INPCAP bit in TxCTL0 register is set to indicate the timer interrupt is because of an input capture event.

If no Capture event occurs, the timer counts up to the 16-bit Compare value stored in the Timer Reload High and Low Byte registers. Upon reaching the Reload value, the timer generates an interrupt, the count value in the Timer High and Low Byte registers is reset to

0001H and counting resumes. The INPCAP bit in TxCTL0 register is cleared to indicate the timer interrupt is not caused by an input capture event.

Follow the steps below for configuring a timer for CAPTURE RESTART mode and initiating the count:

1. Write to the Timer Control register to:
  - Disable the timer.
  - Configure the timer for CAPTURE RESTART mode by writing the TMODE bits in the TxCTL1 register and the TMODEHI bit in TxCTL0 register.
  - Set the prescale value.
  - Set the Capture edge (rising or falling) for the Timer Input.
2. Write to the Timer High and Low Byte registers to set the starting count value (typically 0001H).
3. Write to the Timer Reload High and Low Byte registers to set the Reload value.
4. Clear the Timer PWM High and Low Byte registers to 0000H. This allows the software to determine if interrupts were generated by either a capture event or a reload. If the PWM High and Low Byte registers still contain 0000H after the interrupt, the interrupt was generated by a Reload.
5. Enable the timer interrupt, if appropriate, and set the timer interrupt priority by writing to the relevant interrupt registers. By default, the timer interrupt is generated for both input capture and reload events. If appropriate, configure the timer interrupt to be generated only at the input capture event or the reload event by setting TICONFIG field of the TxCTL0 register.
6. Configure the associated GPIO port pin for the Timer Input alternate function.
7. Write to the Timer Control register to enable the timer and initiate counting.

In CAPTURE mode, the elapsed time from timer start to Capture event can be calculated using the following equation:

$$\text{Capture Elapsed Time (s)} = \frac{(\text{Capture Value} - \text{Start Value}) \times \text{Prescale}}{\text{System Clock Frequency (Hz)}}$$

### COMPARE Mode

In COMPARE mode, the timer counts up to the 16-bit maximum Compare value stored in the Timer Reload High and Low Byte registers. The timer input is the system clock. Upon reaching the Compare value, the timer generates an interrupt and counting continues (the timer value is not reset to 0001H). Also, if the Timer Output alternate function is enabled, the Timer Output pin changes state (from Low to High or from High to Low) upon Compare.

If the Timer reaches FFFFH, the timer rolls over to 0000H and continue counting.

Follow the steps below for configuring a timer for COMPARE mode and initiating the count:

1. Write to the Timer Control register to:
  - Disable the timer.
  - Configure the timer for COMPARE mode.
  - Set the prescale value.
  - Set the initial logic level (High or Low) for the Timer Output alternate function, if appropriate.
2. Write to the Timer High and Low Byte registers to set the starting count value.
3. Write to the Timer Reload High and Low Byte registers to set the Compare value.
4. Enable the timer interrupt, if appropriate, and set the timer interrupt priority by writing to the relevant interrupt registers.
5. If using the Timer Output function, configure the associated GPIO port pin for the Timer Output alternate function.
6. Write to the Timer Control register to enable the timer and initiate counting.

In COMPARE mode, the system clock always provides the timer input. The Compare time can be calculated by the following equation:

$$\text{COMPARE Mode Time (s)} = \frac{(\text{Compare Value} - \text{Start Value}) \times \text{Prescale}}{\text{System Clock Frequency (Hz)}}$$

### **GATED Mode**

In GATED mode, the timer counts only when the Timer Input signal is in its active state (asserted), as determined by the TPOL bit in the Timer Control register. When the Timer Input signal is asserted, counting begins. A timer interrupt is generated when the Timer Input signal is deasserted or a timer reload occurs. To determine if a Timer Input signal deassertion generated the interrupt, read the associated GPIO input value and compare to the value stored in the TPOL bit.

The timer counts up to the 16-bit Reload value stored in the Timer Reload High and Low Byte registers. The timer input is the system clock. When reaching the Reload value, the timer generates an interrupt, the count value in the Timer High and Low Byte registers is reset to 0001H and counting resumes (assuming the Timer Input signal remains asserted). Also, if the Timer Output alternate function is enabled, the Timer Output pin changes state (from Low to High or from High to Low) at timer reset.

Follow the steps below for configuring a timer for GATED mode and initiating the count:

1. Write to the Timer Control register to:
  - Disable the timer.
  - Configure the timer for GATED mode.
  - Set the prescale value.

2. Write to the Timer High and Low Byte registers to set the starting count value. Writing these registers only affects the first pass in GATED mode. After the first timer reset in GATED mode, counting always begins at the reset value of 0001H.
3. Write to the Timer Reload High and Low Byte registers to set the Reload value.
4. Enable the timer interrupt, if appropriate, and set the timer interrupt priority by writing to the relevant interrupt registers. By default, the timer interrupt is generated for both input deassertion and reload events. If appropriate, configure the timer interrupt to be generated only at the input deassertion event or the reload event by setting TICONFIG field of the TxCTL0 register.
5. Configure the associated GPIO port pin for the Timer Input alternate function.
6. Write to the Timer Control register to enable the timer.
7. Assert the Timer Input signal to initiate the counting.

### **CAPTURE/COMPARE Mode**

In CAPTURE/COMPARE mode, the timer begins counting on the first external Timer Input transition. The acceptable transition (rising edge or falling edge) is set by the TPOL bit in the Timer Control Register. The timer input is the system clock.

Every subsequent acceptable transition (after the first) of the Timer Input signal captures the current count value. The Capture value is written to the Timer PWM High and Low Byte Registers. When the Capture event occurs, an interrupt is generated, the count value in the Timer High and Low Byte registers is reset to 0001H, and counting resumes. The INPCAP bit in TxCTL0 register is set to indicate the timer interrupt is caused by an input capture event.

If no Capture event occurs, the timer counts up to the 16-bit Compare value stored in the Timer Reload High and Low Byte registers. Upon reaching the Compare value, the timer generates an interrupt, the count value in the Timer High and Low Byte registers is reset to 0001H and counting resumes. The INPCAP bit in TxCTL0 register is cleared to indicate the timer interrupt is not because of an input capture event.

Follow the steps below for configuring a timer for CAPTURE/COMPARE mode and initiating the count:

1. Write to the Timer Control register to:
  - Disable the timer.
  - Configure the timer for CAPTURE/COMPARE mode.
  - Set the prescale value.
  - Set the Capture edge (rising or falling) for the Timer Input.
2. Write to the Timer High and Low Byte registers to set the starting count value (typically 0001H).
3. Write to the Timer Reload High and Low Byte registers to set the Compare value.

4. Enable the timer interrupt, if appropriate, and set the timer interrupt priority by writing to the relevant interrupt registers. By default, the timer interrupt are generated for both input capture and reload events. If appropriate, configure the timer interrupt to be generated only at the input capture event or the reload event by setting TICONFIG field of the TxCTL0 register.
5. Configure the associated GPIO port pin for the Timer Input alternate function.
6. Write to the Timer Control register to enable the timer.
7. Counting begins on the first appropriate transition of the Timer Input signal. No interrupt is generated by this first edge.

In CAPTURE/COMPARE mode, the elapsed time from timer start to Capture event can be calculated using the following equation:

$$\text{Capture Elapsed Time (s)} = \frac{(\text{Capture Value} - \text{Start Value}) \times \text{Prescale}}{\text{System Clock Frequency (Hz)}}$$

## Reading the Timer Count Values

The current count value in the timers can be read while counting (enabled). This capability has no effect on timer operation. When the timer is enabled and the Timer High Byte register is read, the contents of the Timer Low Byte register are placed in a holding register. A subsequent read from the Timer Low Byte register returns the value in the holding register. This operation allows accurate reads of the full 16-bit timer count value while enabled. When the timers are not enabled, a read from the Timer Low Byte register returns the actual value in the counter.

## Timer Pin Signal Operation

Timer Output is a GPIO Port pin alternate function. The Timer Output is toggled every time the counter is reloaded.

The Timer Input can be used as a selectable counting source. It shares the same pin as the complementary timer output. When selected by the GPIO Alternate Function Registers, this pin functions as a timer input in all modes except for the DUAL PWM OUTPUT mode. For this mode, there is no timer input available.

## Timer Control Register Definitions

### Timer 0–1 Control Registers

#### Time 0–1 Control Register 0

The Timer Control Register 0 (TxCTL0) and Timer Control Register 1 (TxCTL1) determine the timer operating mode (Table 48). It also includes a programmable PWM dead-band delay, two bits to configure timer interrupt definition, and a status bit to identify if the most recent timer interrupt is caused by an input capture event.

**Table 48. Timer 0–1 Control Register 0 (TxCTL0)**

BITS	7	6	5	4	3	2	1	0
FIELD	TMODEHI	TICONFIG		Reserved	PWMD			INPCAP
RESET	0	0	0	0	0	0	0	0
R/W	R/W	R/W	R/W	R/W	R/W	R/W	R/W	R
ADDR	F06H, F0EH							

**TMODEHI**—Timer Mode High Bit

This bit along with the TMODE field in TxCTL1 register determines the operating mode of the timer. This is the most significant bit of the Timer mode selection value. See the TxCTL1 register description for details of the full timer mode decoding.

**TICONFIG**—Timer Interrupt Configuration

This field configures timer interrupt definition.

0x = Timer Interrupt occurs on all defined Reload, Compare and Input Events

10 = Timer Interrupt only on defined Input Capture/Deassertion Events

11 = Timer Interrupt only on defined Reload/Compare Events

Reserved—Must be 0.

**PWMD**—PWM Delay value

This field is a programmable delay to control the number of system clock cycles delay before the Timer Output and the Timer Output Complement are forced to their active state.

000 = No delay

001 = 2 cycles delay

010 = 4 cycles delay

011 = 8 cycles delay

100 = 16 cycles delay

101 = 32 cycles delay

110 = 64 cycles delay

111 = 128 cycles delay

INPCAP—Input Capture Event

This bit indicates if the most recent timer interrupt is caused by a Timer Input Capture Event.

0 = Previous timer interrupt is not a result of Timer Input Capture Event

1 = Previous timer interrupt is a result of Timer Input Capture Event

### Timer 0–1 Control Register 1

The Timer 0–1 Control (TxCTL1) registers enable/disable the timers, set the prescaler value, and determine the timer operating mode (Table 49).

**Table 49. Timer 0–1 Control Register 1 (TxCTL1)**

BITS	7	6	5	4	3	2	1	0
FIELD	TEN	TPOL	PRES			TMODE		
RESET	0	0	0	0	0	0	0	0
R/W	R/W	R/W	R/W	R/W	R/W	R/W	R/W	R/W
ADDR	F07H, F0FH							

TEN—Timer Enable

0 = Timer is disabled.

1 = Timer enabled to count.

TPOL—Timer Input/Output Polarity

Operation of this bit is a function of the current operating mode of the timer.

#### ONE-SHOT mode

When the timer is disabled, the Timer Output signal is set to the value of this bit.

When the timer is enabled, the Timer Output signal is complemented upon timer Reload.

#### CONTINUOUS mode

When the timer is disabled, the Timer Output signal is set to the value of this bit.

When the timer is enabled, the Timer Output signal is complemented upon timer Reload.

#### COUNTER mode

If the timer is enabled the Timer Output signal is complemented after timer reload.

0 = Count occurs on the rising edge of the Timer Input signal.

1 = Count occurs on the falling edge of the Timer Input signal.

#### **PWM SINGLE OUTPUT mode**

0 = Timer Output is forced Low (0) when the timer is disabled. When enabled, the Timer Output is forced High (1) upon PWM count match and forced Low (0) upon Reload.

1 = Timer Output is forced High (1) when the timer is disabled. When enabled, the Timer Output is forced Low (0) upon PWM count match and forced High (1) upon Reload.

#### **CAPTURE mode**

0 = Count is captured on the rising edge of the Timer Input signal.

1 = Count is captured on the falling edge of the Timer Input signal.

#### **COMPARE mode**

When the timer is disabled, the Timer Output signal is set to the value of this bit.

When the timer is enabled, the Timer Output signal is complemented upon timer Reload.

#### **GATED mode**

0 = Timer counts when the Timer Input signal is High (1) and interrupts are generated on the falling edge of the Timer Input.

1 = Timer counts when the Timer Input signal is Low (0) and interrupts are generated on the rising edge of the Timer Input.

#### **CAPTURE/COMPARE mode**

0 = Counting is started on the first rising edge of the Timer Input signal. The current count is captured on subsequent rising edges of the Timer Input signal.

1 = Counting is started on the first falling edge of the Timer Input signal. The current count is captured on subsequent falling edges of the Timer Input signal.

#### **PWM DUAL OUTPUT mode**

0 = Timer Output is forced Low (0) and Timer Output Complement is forced High (1) when the timer is disabled. When enabled, the Timer Output is forced High (1) upon PWM count match and forced Low (0) upon Reload. When enabled, the Timer Output Complement is forced Low (0) upon PWM count match and forced High (1) upon Reload. The PWMD field in TxCTL0 register is a programmable delay to control the number of cycles time delay before the Timer Output and the Timer Output Complement is forced to High (1).

1 = Timer Output is forced High (1) and Timer Output Complement is forced Low (0) when the timer is disabled. When enabled, the Timer Output is forced Low (0) upon PWM count match and forced High (1) upon Reload. When enabled, the Timer Output Complement is forced High (1) upon PWM count match and forced Low (0) upon Reload. The PWMD field in TxCTL0 register is a programmable delay to control the number of cycles time delay before the Timer Output and the Timer Output Complement is forced to Low (0).



**CAPTURE RESTART mode**

0 = Count is captured on the rising edge of the Timer Input signal.  
1 = Count is captured on the falling edge of the Timer Input signal.

**COMPARATOR COUNTER mode**

When the timer is disabled, the Timer Output signal is set to the value of this bit.  
When the timer is enabled, the Timer Output signal is complemented upon timer Reload. Also:

0 = Count is captured on the rising edge of the comparator output.  
1 = Count is captured on the falling edge of the comparator output.



**Caution:** *When the Timer Output alternate function TxOUT on a GPIO port pin is enabled, TxOUT changes to whatever state the TPOL bit is in. The timer does not need to be enabled for that to happen. Also, the Port data direction sub register is not needed to be set to output on TxOUT. Changing the TPOL bit with the timer enabled and running does not immediately change the TxOUT.*

**PRES—Prescale value**

The timer input clock is divided by  $2^{\text{PRES}}$ , where PRES can be set from 0 to 7. The prescaler is reset each time the Timer is disabled. This reset ensures proper clock division each time the Timer is restarted.

- 000 = Divide by 1
- 001 = Divide by 2
- 010 = Divide by 4
- 011 = Divide by 8
- 100 = Divide by 16
- 101 = Divide by 32
- 110 = Divide by 64
- 111 = Divide by 128

**TMODE—Timer mode**

This field along with the TMODEHI bit in TxCTL0 register determines the operating mode of the timer. TMODEHI is the most significant bit of the Timer mode selection value. The entire operating mode bits are expressed as {TMODEHI, TMODE[2:0]}. The TMODEHI is bit 7 of the TxCTL0 register while TMODE[2:0] is the lower 3 bits of the TxCTL1 register.

- 0000 = ONE-SHOT mode
- 0001 = CONTINUOUS mode
- 0010 = COUNTER mode
- 0011 = PWM SINGLE OUTPUT mode
- 0100 = CAPTURE mode
- 0101 = COMPARE mode
- 0110 = GATED mode
- 0111 = CAPTURE/COMPARE mode

- 1000 = PWM DUAL OUTPUT mode
- 1001 = CAPTURE RESTART mode
- 1010 = COMPARATOR COUNTER mode

### Timer 0–1 High and Low Byte Registers

The Timer 0–1 High and Low Byte (TxH and TxL) registers (Table 50 and Table 51) contain the current 16-bit timer count value. When the timer is enabled, a read from TxH causes the value in TxL to be stored in a temporary holding register. A read from TxL always returns this temporary register when the timers are enabled. When the timer is disabled, reads from TxL read the register directly.

Writing to the Timer High and Low Byte registers while the timer is enabled is not recommended. There are no temporary holding registers available for write operations, so simultaneous 16-bit writes are not possible. If either the Timer High or Low Byte registers are written during counting, the 8-bit written value is placed in the counter (High or Low Byte) at the next clock edge. The counter continues counting from the new value.

**Table 50. Timer 0–1 High Byte Register (TxH)**

BITS	7	6	5	4	3	2	1	0
FIELD	TH							
RESET	0	0	0	0	0	0	0	0
R/W	R/W	R/W	R/W	R/W	R/W	R/W	R/W	R/W
ADDR	F00H, F08H							

**Table 51. Timer 0–1 Low Byte Register (TxL)**

BITS	7	6	5	4	3	2	1	0
FIELD	TL							
RESET	0	0	0	0	0	0	0	1
R/W	R/W	R/W	R/W	R/W	R/W	R/W	R/W	R/W
ADDR	F01H, F09H							

TH and TL—Timer High and Low Bytes

These 2 bytes, {TH[7:0], TL[7:0]}, contain the current 16-bit timer count value.

### Timer Reload High and Low Byte Registers

The Timer 0–1 Reload High and Low Byte (TxRH and TxRL) registers (Table 52 and Table 53) store a 16-bit reload value, {TRH[7:0], TRL[7:0]}. Values written to the Timer Reload High Byte register are stored in a temporary holding register. When a write to the

Timer Reload Low Byte register occurs, the temporary holding register value is written to the Timer High Byte register. This operation allows simultaneous updates of the 16-bit Timer Reload value.

In COMPARE mode, the Timer Reload High and Low Byte registers store the 16-bit Compare value.

**Table 52. Timer 0–1 Reload High Byte Register (TxRH)**

BITS	7	6	5	4	3	2	1	0
FIELD	TRH							
RESET	1	1	1	1	1	1	1	1
R/W	R/W	R/W	R/W	R/W	R/W	R/W	R/W	R/W
ADDR	F02H, F0AH							

**Table 53. Timer 0–1 Reload Low Byte Register (TxRL)**

BITS	7	6	5	4	3	2	1	0
FIELD	TRL							
RESET	1	1	1	1	1	1	1	1
R/W	R/W	R/W	R/W	R/W	R/W	R/W	R/W	R/W
ADDR	F03H, F0BH							

TRH and TRL—Timer Reload Register High and Low

These two bytes form the 16-bit Reload value, {TRH[7:0], TRL[7:0]}. This value sets the maximum count value which initiates a timer reload to 0001H. In COMPARE mode, these two bytes form the 16-bit Compare value.

### Timer 0-1 PWM High and Low Byte Registers

The Timer 0-1 PWM High and Low Byte (TxPWMH and TxPWML) registers (Table 54 and Table 55) control Pulse-Width Modulator (PWM) operations. These registers also store the Capture values for the CAPTURE and CAPTURE/COMPARE modes.

**Table 54. Timer 0–1 PWM High Byte Register (TxPWMH)**

BITS	7	6	5	4	3	2	1	0
FIELD	PWMH							
RESET	0	0	0	0	0	0	0	0
R/W	R/W	R/W	R/W	R/W	R/W	R/W	R/W	R/W
ADDR	F04H, F0CH							

**Table 55. Timer 0–1 PWM Low Byte Register (TxPWML)**

BITS	7	6	5	4	3	2	1	0
FIELD	PWML							
RESET	0	0	0	0	0	0	0	0
R/W	R/W	R/W	R/W	R/W	R/W	R/W	R/W	R/W
ADDR	F05H, F0DH							

**PWMH and PWML—Pulse-Width Modulator High and Low Bytes**

These two bytes, {PWMH[7:0], PWML[7:0]}, form a 16-bit value that is compared to the current 16-bit timer count. When a match occurs, the PWM output changes state. The PWM output value is set by the TPOL bit in the Timer Control Register (TxCTL1) register.

The TxPWMH and TxPWML registers also store the 16-bit captured timer value when operating in CAPTURE or CAPTURE/COMPARE modes.



# Watchdog Timer

The Watchdog Timer (WDT) protects against corrupt or unreliable software, power faults, and other system-level problems which may place the Z8 Encore! XP<sup>®</sup> F082A Series devices into unsuitable operating states. The features of Watchdog Timer include:

- On-chip RC oscillator.
- A selectable time-out response: reset or interrupt.
- 24-bit programmable time-out value.

## Operation

The Watchdog Timer is a one-shot timer that resets or interrupts the Z8 Encore! XP F082A Series devices when the WDT reaches its terminal count. The Watchdog Timer uses a dedicated on-chip RC oscillator as its clock source. The Watchdog Timer operates in only two modes: ON and OFF. Once enabled, it always counts and must be refreshed to prevent a time-out. Perform an enable by executing the WDT instruction or by setting the WDT\_AO Flash Option Bit. The WDT\_AO bit forces the Watchdog Timer to operate immediately upon reset, even if a WDT instruction has not been executed.

The Watchdog Timer is a 24-bit reloadable downcounter that uses three 8-bit registers in the eZ8 CPU register space to set the reload value. The nominal WDT time-out period is described by the following equation:

$$\text{WDT Time-out Period (ms)} = \frac{\text{WDT Reload Value}}{10}$$

where the WDT reload value is the decimal value of the 24-bit value given by {WDTU[7:0], WDTM[7:0], WDTL[7:0]} and the typical Watchdog Timer RC oscillator frequency is 10 kHz. The Watchdog Timer cannot be refreshed after it reaches 000002H. The WDT Reload Value must not be set to values below 000004H. [Table 56](#) provides information about approximate time-out delays for the minimum and maximum WDT reload values.

**Table 56. Watchdog Timer Approximate Time-Out Delays**

WDT Reload Value (Hex)	WDT Reload Value (Decimal)	Approximate Time-Out Delay (with 10 kHz typical WDT oscillator frequency)	
		Typical	Description
000004	4	400 μs	Minimum time-out delay
FFFFFF	16,777,215	28 minutes	Maximum time-out delay

## Watchdog Timer Refresh

When first enabled, the Watchdog Timer is loaded with the value in the Watchdog Timer Reload registers. The Watchdog Timer counts down to 000000H unless a WDT instruction is executed by the eZ8 CPU. Execution of the WDT instruction causes the downcounter to be reloaded with the WDT Reload value stored in the Watchdog Timer Reload registers. Counting resumes following the reload operation.

When the Z8 Encore! XP<sup>®</sup> F082A Series devices are operating in DEBUG mode (using the on-chip debugger), the Watchdog Timer is continuously refreshed to prevent any Watchdog Timer time-outs.

## Watchdog Timer Time-Out Response

The Watchdog Timer times out when the counter reaches 000000H. A time-out of the Watchdog Timer generates either an interrupt or a system reset. The WDT\_RES Flash Option Bit determines the time-out response of the Watchdog Timer. For information on programming the WDT\_RES Flash Option Bit, see [Flash Option Bits](#) on page 153.

### WDT Interrupt in Normal Operation

If configured to generate an interrupt when a time-out occurs, the Watchdog Timer issues an interrupt request to the interrupt controller and sets the WDT status bit in the Reset Status (RSTSTAT) register (see [Reset Status Register](#) on page 30). If interrupts are enabled, the eZ8 CPU responds to the interrupt request by fetching the Watchdog Timer interrupt vector and executing code from the vector address. After time-out and interrupt generation, the Watchdog Timer counter rolls over to its maximum value of FFFFH and continues counting. The Watchdog Timer counter is not automatically returned to its Reload Value.

The Reset Status (RSTSTAT) register must be read before clearing the WDT interrupt. This read clears the WDT timeout Flag and prevents further WDT interrupts from immediately occurring.

### WDT Interrupt in STOP Mode

If configured to generate an interrupt when a time-out occurs and the Z8 Encore! XP F082A Series devices are in STOP mode, the Watchdog Timer automatically initiates a Stop Mode Recovery and generates an interrupt request. Both the WDT status bit and the STOP bit in the Reset Status (RSTSTAT) register are set to 1 following a WDT time-out in STOP mode. For more information on Stop Mode Recovery, see [Reset, Stop Mode Recovery, and Low Voltage Detection](#) on page 23.

If interrupts are enabled, following completion of the Stop Mode Recovery the eZ8 CPU responds to the interrupt request by fetching the Watchdog Timer interrupt vector and executing code from the vector address.

### WDT Reset in Normal Operation

If configured to generate a Reset when a time-out occurs, the Watchdog Timer forces the device into the System Reset state. The WDT status bit in the Reset Status (RSTSTAT) register is set to 1. For more information on system reset, see [Reset, Stop Mode Recovery, and Low Voltage Detection](#) on page 23.

### WDT Reset in STOP Mode

If configured to generate a Reset when a time-out occurs and the device is in STOP mode, the Watchdog Timer initiates a Stop Mode Recovery. Both the WDT status bit and the STOP bit in the Reset Status (RSTSTAT) register are set to 1 following WDT time-out in STOP mode.

## Watchdog Timer Reload Unlock Sequence

Writing the unlock sequence to the Watchdog Timer (WDTCTL) Control register address unlocks the three Watchdog Timer Reload Byte registers (WDTU, WDTM, and WDTL) to allow changes to the time-out period. These write operations to the WDTCTL register address produce no effect on the bits in the WDTCTL register. The locking mechanism prevents spurious writes to the Reload registers. Follow the steps below to unlock the Watchdog Timer Reload Byte registers (WDTU, WDTM, and WDTL) for write access.

1. Write 55H to the Watchdog Timer Control register (WDTCTL).
2. Write AAH to the Watchdog Timer Control register (WDTCTL).
3. Write the Watchdog Timer Reload Upper Byte register (WDTU) with the desired time-out value.
4. Write the Watchdog Timer Reload High Byte register (WDTM) with the desired time-out value.
5. Write the Watchdog Timer Reload Low Byte register (WDTL) with the desired time-out value.

All three Watchdog Timer Reload registers must be written in the order just listed. There must be no other register writes between each of these operations. If a register write occurs, the lock state machine resets and no further writes can occur unless the sequence is restarted. The value in the Watchdog Timer Reload registers is loaded into the counter when the Watchdog Timer is first enabled and every time a WDT instruction is executed.

## Watchdog Timer Calibration

Due to its extremely low operating current, the Watchdog Timer oscillator is somewhat inaccurate. This variation can be corrected using the calibration data stored in the Flash Information Page (see [Table 97](#) and [Table 98](#) on page 165). Loading these values into the



Watchdog Timer Reload Registers results in a one-second timeout at room temperature and 3.3 V supply voltage.

Timeouts other than one second may be obtained by scaling the calibration values up or down as required.

- **Note:** *The Watchdog Timer accuracy still degrades as temperature and supply voltage vary. See [Table 133](#) on page 230 for details.*

## Watchdog Timer Control Register Definitions

### Watchdog Timer Control Register

The Watchdog Timer Control (WDTCTL) register is a write-only control register. Writing the 55H, AAH unlock sequence to the WDTCTL register address unlocks the three Watchdog Timer Reload Byte registers (WDTU, WDTL, and WDTL) to allow changes to the time-out period. These write operations to the WDTCTL register address produce no effect on the bits in the WDTCTL register. The locking mechanism prevents spurious writes to the Reload registers.

This register address is shared with the read-only Reset Status register.

**Table 57. Watchdog Timer Control Register (WDTCTL)**

BITS	7	6	5	4	3	2	1	0
FIELD	WDTUNLK							
RESET	X	X	X	X	X	X	X	X
R/W	W	W	W	W	W	W	W	W
ADDR	FF0H							
X = Undefined.								

WDTUNLK—Watchdog Timer Unlock

The software must write the correct unlocking sequence to this register before it is allowed to modify the contents of the Watchdog Timer reload registers.

### Watchdog Timer Reload Upper, High and Low Byte Registers

The Watchdog Timer Reload Upper, High and Low Byte (WDTU, WDTL, and WDTL) registers ([Table 58](#) through [Table 60](#)) form the 24-bit reload value that is loaded into the Watchdog Timer when a WDT instruction executes. The 24-bit reload value is {WDTU[7:0], WDTL[7:0], WDTL[7:0]}. Writing to these registers sets the appropriate Reload Value. Reading from these registers returns the current Watchdog Timer count value.



**Caution:** *The 24-bit WDT Reload Value must not be set to a value less than 000004H.*

**Table 58. Watchdog Timer Reload Upper Byte Register (WDTU)**

BITS	7	6	5	4	3	2	1	0
FIELD	WDTU							
RESET	00H							
R/W	R/W*							
ADDR	FF1H							
R/W* - Read returns the current WDT count value. Write sets the appropriate Reload Value.								

WDTU—WDT Reload Upper Byte  
Most-significant byte (MSB), Bits[23:16], of the 24-bit WDT reload value.

**Table 59. Watchdog Timer Reload High Byte Register (WDTH)**

BITS	7	6	5	4	3	2	1	0
FIELD	WDTH							
RESET	04H							
R/W	R/W*							
ADDR	FF2H							
R/W* - Read returns the current WDT count value. Write sets the appropriate Reload Value.								

WDTH—WDT Reload High Byte  
Middle byte, Bits[15:8], of the 24-bit WDT reload value.

**Table 60. Watchdog Timer Reload Low Byte Register (WDTL)**

BITS	7	6	5	4	3	2	1	0
FIELD	WDTL							
RESET	00H							
R/W	R/W*							
ADDR	FF3H							
R/W* - Read returns the current WDT count value. Write sets the appropriate Reload Value.								

WDTL—WDT Reload Low  
Least significant byte (LSB), Bits[7:0], of the 24-bit WDT reload value.



# Universal Asynchronous Receiver/Transmitter

The universal asynchronous receiver/transmitter (UART) is a full-duplex communication channel capable of handling asynchronous data transfers. The UART uses a single 8-bit data mode with selectable parity. Features of the UART include:

- 8-bit asynchronous data transfer.
- Selectable even- and odd-parity generation and checking.
- Option of one or two STOP bits.
- Separate transmit and receive interrupts.
- Framing, parity, overrun and break detection.
- Separate transmit and receive enables.
- 16-bit baud rate generator (BRG).
- Selectable MULTIPROCESSOR (9-bit) mode with three configurable interrupt schemes.
- Baud rate generator (BRG) can be configured and used as a basic 16-bit timer.
- Driver enable (DE) output for external bus transceivers.

## Architecture

The UART consists of three primary functional blocks: transmitter, receiver, and baud rate generator. The UART's transmitter and receiver function independently, but employ the same baud rate and data format. [Figure 10](#) on page 98 displays the UART architecture.

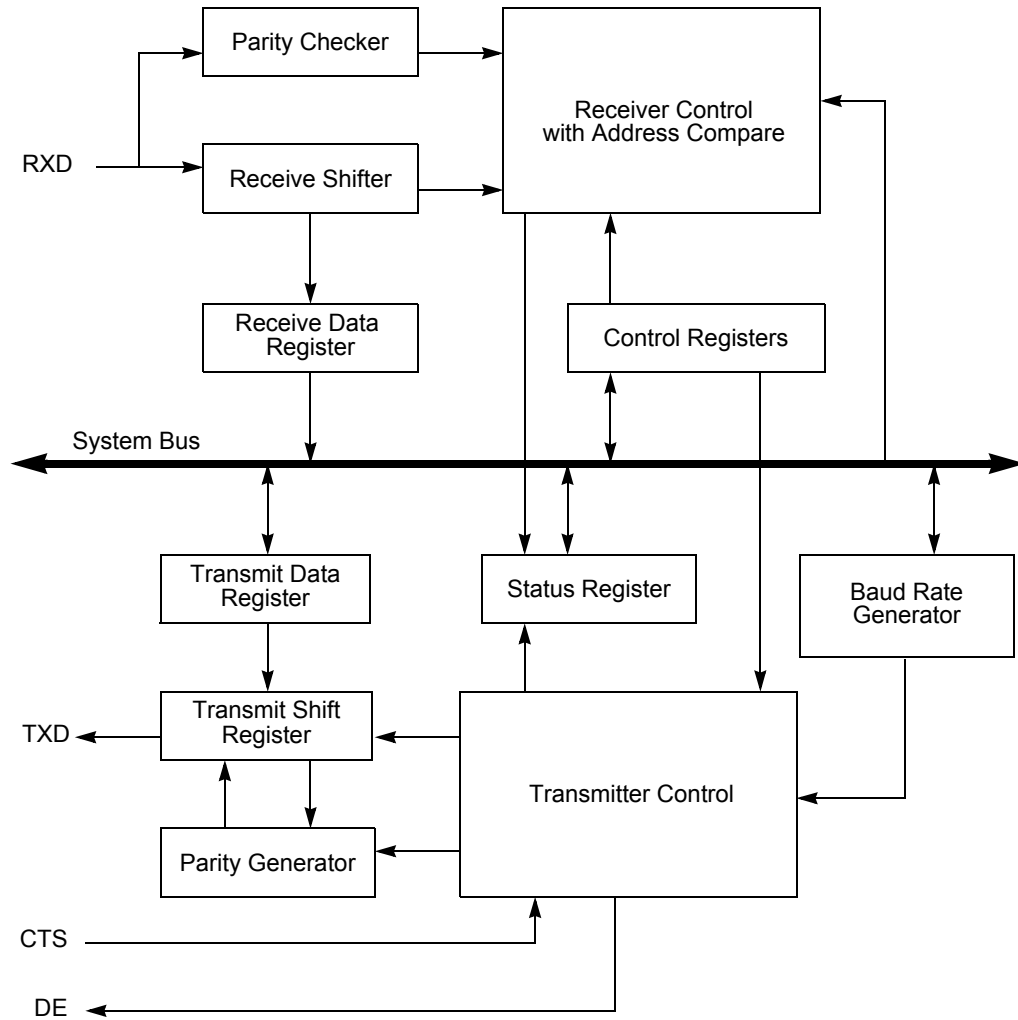
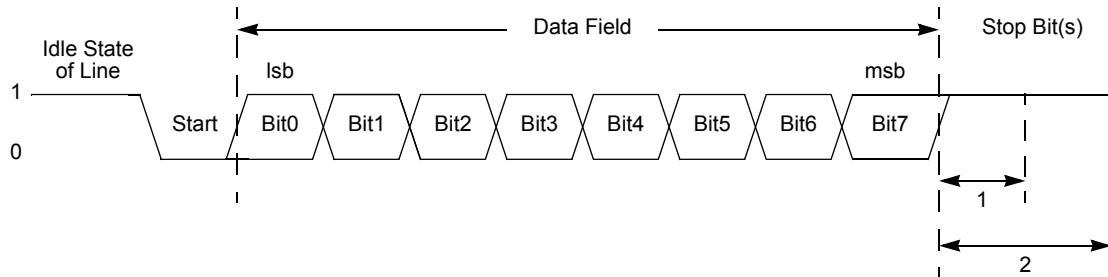

Figure 10. UART Block Diagram

## Operation

### Data Format

The UART always transmits and receives data in an 8-bit data format, least-significant bit first. An even or odd parity bit can be added to the data stream. Each character begins with an active Low START bit and ends with either 1 or 2 active High STOP bits. [Figure 11](#) and [Figure 12](#) display the asynchronous data format employed by the UART without parity and with parity, respectively.



**Figure 11. UART Asynchronous Data Format without Parity**

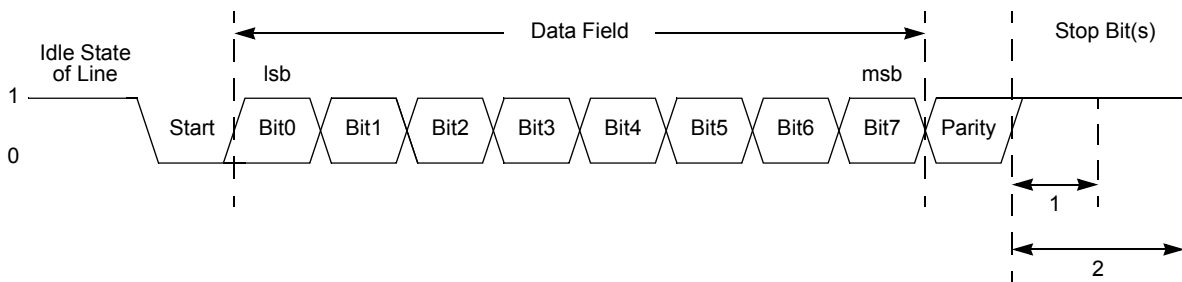

**Figure 12. UART Asynchronous Data Format with Parity**

### Transmitting Data using the Polled Method

Follow the steps below to transmit data using the polled method of operation:

1. Write to the UART Baud Rate High and Low Byte registers to set the required baud rate.
2. Enable the UART pin functions by configuring the associated GPIO Port pins for alternate function operation.
3. Write to the UART Control 1 register, if MULTIPROCESSOR mode is appropriate, to enable MULTIPROCESSOR (9-bit) mode functions.
4. Set the Multiprocessor Mode Select (MPEN) bit to enable MULTIPROCESSOR mode.
5. Write to the UART Control 0 register to:
  - Set the transmit enable bit (TEN) to enable the UART for data transmission.
  - Set the parity enable bit (PEN), if parity is appropriate and MULTIPROCESSOR mode is not enabled, and select either even or odd parity (PSEL).
  - Set or clear the CTSE bit to enable or disable control from the remote receiver using the  $\overline{\text{CTS}}$  pin.

6. Check the TDRE bit in the UART Status 0 register to determine if the Transmit Data register is empty (indicated by a 1). If empty, continue to [Step 7](#). If the Transmit Data register is full (indicated by a 0), continue to monitor the TDRE bit until the Transmit Data register becomes available to receive new data.
7. Write the UART Control 1 register to select the outgoing address bit.
8. Set the Multiprocessor Bit Transmitter (MPBT) if sending an address byte, clear it if sending a data byte.
9. Write the data byte to the UART Transmit Data register. The transmitter automatically transfers the data to the Transmit Shift register and transmits the data.
10. Make any changes to the Multiprocessor Bit Transmitter (MPBT) value, if appropriate and MULTIPROCESSOR mode is enabled.
11. To transmit additional bytes, return to [Step 5](#).

### Transmitting Data using the Interrupt-Driven Method

The UART Transmitter interrupt indicates the availability of the Transmit Data register to accept new data for transmission. Follow the steps below to configure the UART for interrupt-driven data transmission:

1. Write to the UART Baud Rate High and Low Byte registers to set the appropriate baud rate.
2. Enable the UART pin functions by configuring the associated GPIO Port pins for alternate function operation.
3. Execute a DI instruction to disable interrupts.
4. Write to the Interrupt control registers to enable the UART Transmitter interrupt and set the acceptable priority.
5. Write to the UART Control 1 register to enable MULTIPROCESSOR (9-bit) mode functions, if MULTIPROCESSOR mode is appropriate.
6. Set the MULTIPROCESSOR Mode Select (MPEN) to Enable MULTIPROCESSOR mode.
7. Write to the UART Control 0 register to:
  - Set the transmit enable bit (TEN) to enable the UART for data transmission.
  - Enable parity, if appropriate and if MULTIPROCESSOR mode is not enabled, and select either even or odd parity.
  - Set or clear CTSE to enable or disable control from the remote receiver using the  $\overline{\text{CTS}}$  pin.
8. Execute an EI instruction to enable interrupts.

The UART is now configured for interrupt-driven data transmission. Because the UART Transmit Data register is empty, an interrupt is generated immediately. When the UART Transmit interrupt is detected, the associated interrupt service routine (ISR) performs the following:

1. Write the UART Control 1 register to select the multiprocessor bit for the byte to be transmitted:
2. Set the Multiprocessor Bit Transmitter (MPBT) if sending an address byte, clear it if sending a data byte.
3. Write the data byte to the UART Transmit Data register. The transmitter automatically transfers the data to the Transmit Shift register and transmits the data.
4. Clear the UART Transmit interrupt bit in the applicable Interrupt Request register.
5. Execute the IRET instruction to return from the interrupt-service routine and wait for the Transmit Data register to again become empty.

### Receiving Data using the Polled Method

Follow the steps below to configure the UART for polled data reception:

1. Write to the UART Baud Rate High and Low Byte registers to set an acceptable baud rate for the incoming data stream.
2. Enable the UART pin functions by configuring the associated GPIO Port pins for alternate function operation.
3. Write to the UART Control 1 register to enable MULTIPROCESSOR mode functions, if appropriate.
4. Write to the UART Control 0 register to:
  - Set the receive enable bit (REN) to enable the UART for data reception
  - Enable parity, if appropriate and if Multiprocessor mode is not enabled, and select either even or odd parity.
5. Check the RDA bit in the UART Status 0 register to determine if the Receive Data register contains a valid data byte (indicated by a 1). If RDA is set to 1 to indicate available data, continue to [Step 5](#). If the Receive Data register is empty (indicated by a 0), continue to monitor the RDA bit awaiting reception of the valid data.
6. Read data from the UART Receive Data register. If operating in MULTIPROCESSOR (9-bit) mode, further actions may be required depending on the MULTIPROCESSOR mode bits MPMD[1:0].
7. Return to [Step 4](#) to receive additional data.



## Receiving Data using the Interrupt-Driven Method

The UART Receiver interrupt indicates the availability of new data (as well as error conditions). Follow the steps below to configure the UART receiver for interrupt-driven operation:

1. Write to the UART Baud Rate High and Low Byte registers to set the acceptable baud rate.
2. Enable the UART pin functions by configuring the associated GPIO Port pins for alternate function operation.
3. Execute a DI instruction to disable interrupts.
4. Write to the Interrupt control registers to enable the UART Receiver interrupt and set the acceptable priority.
5. Clear the UART Receiver interrupt in the applicable Interrupt Request register.
6. Write to the UART Control 1 Register to enable Multiprocessor (9-bit) mode functions, if appropriate.
  - Set the Multiprocessor Mode Select (MPEN) to Enable MULTIPROCESSOR mode.
  - Set the Multiprocessor Mode Bits, MPMD[1:0], to select the acceptable address matching scheme.
  - Configure the UART to interrupt on received data and errors or errors only (interrupt on errors only is unlikely to be useful for Z8 Encore!<sup>®</sup> devices without a DMA block)
7. Write the device address to the Address Compare Register (automatic MULTIPROCESSOR modes only).
8. Write to the UART Control 0 register to:
  - Set the receive enable bit (REN) to enable the UART for data reception
  - Enable parity, if appropriate and if multiprocessor mode is not enabled, and select either even or odd parity.
9. Execute an EI instruction to enable interrupts.

The UART is now configured for interrupt-driven data reception. When the UART Receiver interrupt is detected, the associated interrupt service routine (ISR) performs the following:

1. Checks the UART Status 0 register to determine the source of the interrupt - error, break, or received data.
2. Reads the data from the UART Receive Data register if the interrupt was because of data available. If operating in MULTIPROCESSOR (9-bit) mode, further actions may be required depending on the MULTIPROCESSOR mode bits MPMD[1:0].

3. Clears the UART Receiver interrupt in the applicable Interrupt Request register.
4. Executes the IRET instruction to return from the interrupt-service routine and await more data.

### Clear To Send (CTS) Operation

The CTS pin, if enabled by the CTSE bit of the UART Control 0 register, performs flow control on the outgoing transmit datastream. The Clear To Send ( $\overline{\text{CTS}}$ ) input pin is sampled one system clock before beginning any new character transmission. To delay transmission of the next data character, an external receiver must deassert  $\overline{\text{CTS}}$  at least one system clock cycle before a new data transmission begins. For multiple character transmissions, this action is typically performed during Stop Bit transmission. If  $\overline{\text{CTS}}$  deasserts in the middle of a character transmission, the current character is sent completely.

### MULTIPROCESSOR (9-bit) Mode

The UART has a MULTIPROCESSOR (9-bit) mode that uses an extra (9th) bit for selective communication when a number of processors share a common UART bus. In MULTIPROCESSOR mode (also referred to as 9-bit mode), the multiprocessor bit (MP) is transmitted immediately following the 8-bits of data and immediately preceding the Stop bit(s) as displayed in Figure 13. The character format is:

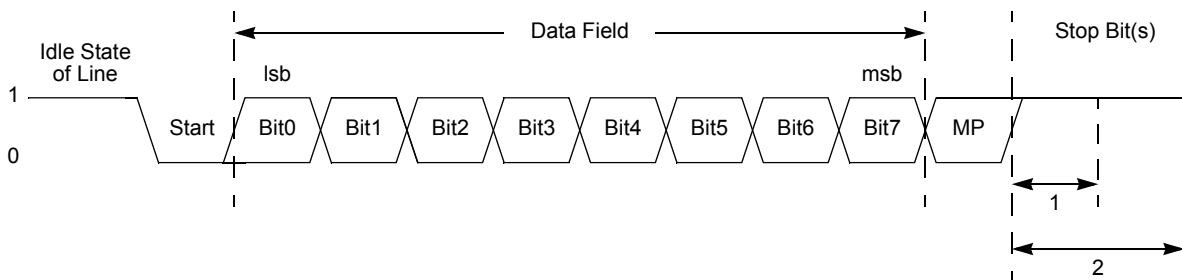

**Figure 13. UART Asynchronous MULTIPROCESSOR Mode Data Format**

In MULTIPROCESSOR (9-bit) mode, the Parity bit location (9th bit) becomes the Multiprocessor control bit. The UART Control 1 and Status 1 registers provide MULTIPROCESSOR (9-bit) mode control and status information. If an automatic address matching scheme is enabled, the UART Address Compare register holds the network address of the device.

### MULTIPROCESSOR (9-bit) Mode Receive Interrupts

When MULTIPROCESSOR mode is enabled, the UART only processes frames addressed to it. The determination of whether a frame of data is addressed to the UART can be made in hardware, software or some combination of the two, depending on the multiprocessor

configuration bits. In general, the address compare feature reduces the load on the CPU, because it does not require access to the UART when it receives data directed to other devices on the multi-node network. The following three MULTIPROCESSOR modes are available in hardware:

1. Interrupt on all address bytes.
2. Interrupt on matched address bytes and correctly framed data bytes.
3. Interrupt only on correctly framed data bytes.

These modes are selected with MPMD [1 : 0] in the UART Control 1 Register. For all multiprocessor modes, bit MPEN of the UART Control 1 Register must be set to 1.

The first scheme is enabled by writing 01b to MPMD[1:0]. In this mode, all incoming address bytes cause an interrupt, while data bytes never cause an interrupt. The interrupt service routine must manually check the address byte that caused triggered the interrupt. If it matches the UART address, the software clears MPMD[0]. Each new incoming byte interrupts the CPU. The software is responsible for determining the end of the frame. It checks for the end-of-frame by reading the MPRX bit of the UART Status 1 Register for each incoming byte. If MPRX=1, a new frame has begun. If the address of this new frame is different from the UART's address, MPMD[0] must be set to 1 causing the UART interrupts to go inactive until the next address byte. If the new frame's address matches the UART's, the data in the new frame is processed as well.

The second scheme requires the following: set MPMD[1:0] to 10B and write the UART's address into the UART Address Compare Register. This mode introduces additional hardware control, interrupting only on frames that match the UART's address. When an incoming address byte does not match the UART's address, it is ignored. All successive data bytes in this frame are also ignored. When a matching address byte occurs, an interrupt is issued and further interrupts now occur on each successive data byte. When the first data byte in the frame is read, the NEWFRM bit of the UART Status 1 Register is asserted. All successive data bytes have NEWFRM=0. When the next address byte occurs, the hardware compares it to the UART's address. If there is a match, the interrupts continues and the NEWFRM bit is set for the first byte of the new frame. If there is no match, the UART ignores all incoming bytes until the next address match.

The third scheme is enabled by setting MPMD[1:0] to 11b and by writing the UART's address into the UART Address Compare Register. This mode is identical to the second scheme, except that there are no interrupts on address bytes. The first data byte of each frame remains accompanied by a NEWFRM assertion.

## External Driver Enable

The UART provides a Driver Enable (DE) signal for off-chip bus transceivers. This feature reduces the software overhead associated with using a GPIO pin to control the transceiver when communicating on a multi-transceiver bus, such as RS-485.

Driver Enable is an active High signal that envelopes the entire transmitted data frame including parity and Stop bits as displayed in Figure 14. The Driver Enable signal asserts when a byte is written to the UART Transmit Data register. The Driver Enable signal asserts at least one UART bit period and no greater than two UART bit periods before the Start bit is transmitted. This allows a setup time to enable the transceiver. The Driver Enable signal deasserts one system clock period after the final Stop bit is transmitted. This one system clock delay allows both time for data to clear the transceiver before disabling it, as well as the ability to determine if another character follows the current character. In the event of back to back characters (new data must be written to the Transmit Data Register before the previous character is completely transmitted) the DE signal is not deasserted between characters. The DEPOL bit in the UART Control Register 1 sets the polarity of the Driver Enable signal.

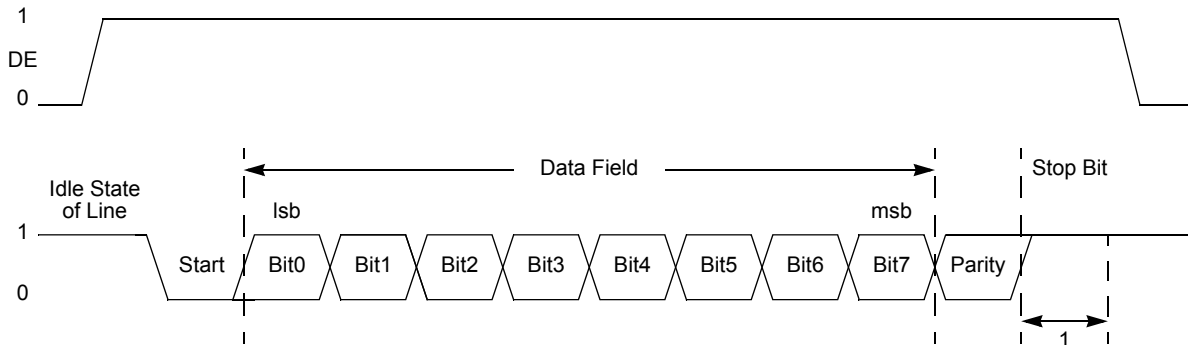

**Figure 14. UART Driver Enable Signal Timing (shown with 1 Stop Bit and Parity)**

The Driver Enable to Start bit setup time is calculated as follows:

$$\left( \frac{1}{\text{Baud Rate (Hz)}} \right) \leq \text{DE to Start Bit Setup Time (s)} \leq \left( \frac{2}{\text{Baud Rate (Hz)}} \right)$$

## UART Interrupts

The UART features separate interrupts for the transmitter and the receiver. In addition, when the UART primary functionality is disabled, the Baud Rate Generator can also function as a basic timer with interrupt capability.

### Transmitter Interrupts

The transmitter generates a single interrupt when the Transmit Data Register Empty bit (TDRE) is set to 1. This indicates that the transmitter is ready to accept new data for transmission. The TDRE interrupt occurs after the Transmit shift register has shifted the first bit of data out. The Transmit Data register can now be written with the next character to

send. This action provides 7 bit periods of latency to load the Transmit Data register before the Transmit shift register completes shifting the current character. Writing to the UART Transmit Data register clears the TDRE bit to 0.

### Receiver Interrupts

The receiver generates an interrupt when any of the following occurs:

- A data byte is received and is available in the UART Receive Data register. This interrupt can be disabled independently of the other receiver interrupt sources. The received data interrupt occurs after the receive character has been received and placed in the Receive Data register. To avoid an overrun error, software must respond to this received data available condition before the next character is completely received.

► **Note:** *In MULTIPROCESSOR mode ( $MPEN = 1$ ), the receive data interrupts are dependent on the multiprocessor configuration and the most recent address byte.*

- A break is received.
- An overrun is detected.
- A data framing error is detected.

### UART Overrun Errors

When an overrun error condition occurs the UART prevents overwriting of the valid data currently in the Receive Data register. The Break Detect and Overrun status bits are not displayed until after the valid data has been read.

After the valid data has been read, the UART Status 0 register is updated to indicate the overrun condition (and Break Detect, if applicable). The RDA bit is set to 1 to indicate that the Receive Data register contains a data byte. However, because the overrun error occurred, this byte may not contain valid data and must be ignored. The BRKD bit indicates if the overrun was caused by a break condition on the line. After reading the status byte indicating an overrun error, the Receive Data register must be read again to clear the error bits in the UART Status 0 register. Updates to the Receive Data register occur only when the next data word is received.

### UART Data and Error Handling Procedure

Figure 15 displays the recommended procedure for use in UART receiver interrupt service routines.

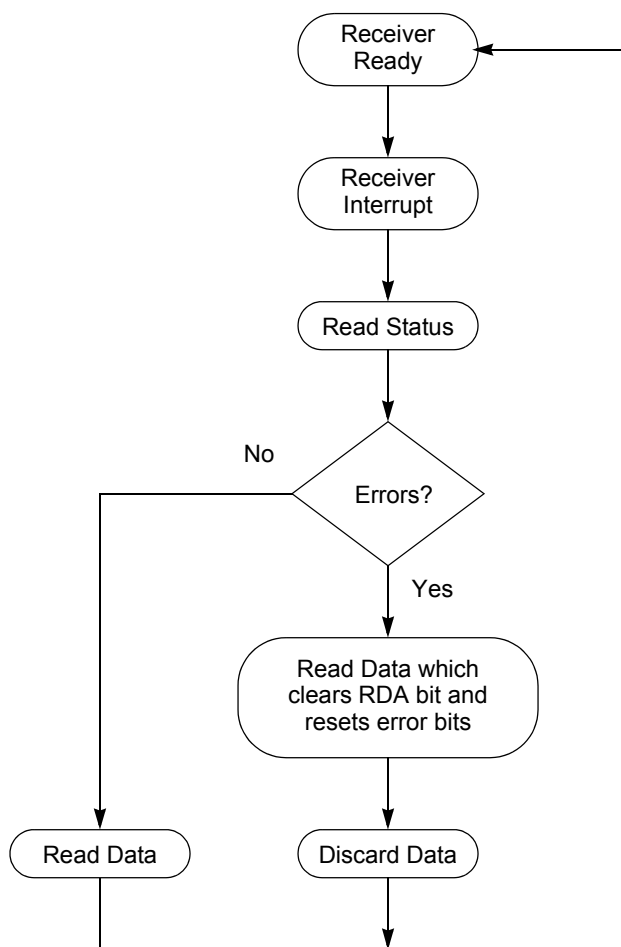

**Figure 15. UART Receiver Interrupt Service Routine Flow**

### Baud Rate Generator Interrupts

If the baud rate generator (BRG) interrupt enable is set, the UART Receiver interrupt asserts when the UART Baud Rate Generator reloads. This condition allows the Baud Rate Generator to function as an additional counter if the UART functionality is not employed.

### UART Baud Rate Generator

The UART Baud Rate Generator creates a lower frequency baud rate clock for data transmission. The input to the Baud Rate Generator is the system clock. The UART Baud Rate High and Low Byte registers combine to create a 16-bit baud rate divisor value

(BRG[15:0]) that sets the data transmission rate (baud rate) of the UART. The UART data rate is calculated using the following equation:

$$\text{UART Data Rate (bits/s)} = \frac{\text{System Clock Frequency (Hz)}}{16 \times \text{UART Baud Rate Divisor Value}}$$

When the UART is disabled, the Baud Rate Generator functions as a basic 16-bit timer with interrupt on time-out. Follow the steps below to configure the Baud Rate Generator as a timer with interrupt on time-out:

1. Disable the UART by clearing the REN and TEN bits in the UART Control 0 register to 0.
2. Load the acceptable 16-bit count value into the UART Baud Rate High and Low Byte registers.
3. Enable the Baud Rate Generator timer function and associated interrupt by setting the BRGCTL bit in the UART Control 1 register to 1.

When configured as a general purpose timer, the interrupt interval is calculated using the following equation:

$$\text{Interrupt Interval(s)} = \text{System Clock Period (s)} \times \text{BRG[15:0]}$$

## UART Control Register Definitions

The UART control registers support the UART and the associated Infrared Encoder/Decoders. For more information on infrared operation, see [Infrared Encoder/Decoder](#) on page 117.

### UART Control 0 and Control 1 Registers

The UART Control 0 (UxCTL0) and Control 1 (UxCTL1) registers ([Table 61](#) and [Table 62](#)) configure the properties of the UART's transmit and receive operations. The UART Control registers must not be written while the UART is enabled.

**Table 61. UART Control 0 Register (U0CTL0)**

BITS	7	6	5	4	3	2	1	0
FIELD	TEN	REN	CTSE	PEN	PSEL	SBRK	STOP	LBEN
RESET	0	0	0	0	0	0	0	0
R/W	R/W	R/W	R/W	R/W	R/W	R/W	R/W	R/W
ADDR	F42H							

TEN—Transmit Enable

This bit enables or disables the transmitter. The enable is also controlled by the  $\overline{\text{CTS}}$  signal

and the CTSE bit. If the  $\overline{\text{CTS}}$  signal is Low and the CTSE bit is 1, the transmitter is enabled.

0 = Transmitter disabled.

1 = Transmitter enabled.

REN—Receive Enable

This bit enables or disables the receiver.

0 = Receiver disabled.

1 = Receiver enabled.

CTSE—CTS Enable

0 = The  $\overline{\text{CTS}}$  signal has no effect on the transmitter.

1 = The UART recognizes the  $\overline{\text{CTS}}$  signal as an enable control from the transmitter.

PEN—Parity Enable

This bit enables or disables parity. Even or odd is determined by the PSEL bit.

0 = Parity is disabled.

1 = The transmitter sends data with an additional parity bit and the receiver receives an additional parity bit.

PSEL—Parity Select

0 = Even parity is transmitted and expected on all received data.

1 = Odd parity is transmitted and expected on all received data.

SBRK—Send Break

This bit pauses or breaks data transmission. Sending a break interrupts any transmission in progress, so ensure that the transmitter has finished sending data before setting this bit.

0 = No break is sent.

1 = Forces a break condition by setting the output of the transmitter to zero.

STOP—Stop Bit Select

0 = The transmitter sends one stop bit.

1 = The transmitter sends two stop bits.

LBEN—Loop Back Enable

0 = Normal operation.

1 = All transmitted data is looped back to the receiver.

**Table 62. UART Control 1 Register (U0CTL1)**

BITS	7	6	5	4	3	2	1	0
FIELD	MPMD[1]	MPEN	MPMD[0]	MPBT	DEPOL	BRGCTL	RDAIRQ	IREN
RESET	0	0	0	0	0	0	0	0
R/W	R/W	R/W	R/W	R/W	R/W	R/W	R/W	R/W
ADDR	F43H							



MPMD[1:0]—MULTIPROCESSOR Mode

If MULTIPROCESSOR (9-bit) mode is enabled,

00 = The UART generates an interrupt request on all received bytes (data and address).

01 = The UART generates an interrupt request only on received address bytes.

10 = The UART generates an interrupt request when a received address byte matches the value stored in the Address Compare Register and on all successive data bytes until an address mismatch occurs.

11 = The UART generates an interrupt request on all received data bytes for which the most recent address byte matched the value in the Address Compare Register.

MPEN—MULTIPROCESSOR (9-bit) Enable

This bit is used to enable MULTIPROCESSOR (9-bit) mode.

0 = Disable MULTIPROCESSOR (9-bit) mode.

1 = Enable MULTIPROCESSOR (9-bit) mode.

MPBT—Multiprocessor Bit Transmit

This bit is applicable only when MULTIPROCESSOR (9-bit) mode is enabled. The 9th bit is used by the receiving device to determine if the data byte contains address or data information.

0 = Send a 0 in the multiprocessor bit location of the data stream (data byte).

1 = Send a 1 in the multiprocessor bit location of the data stream (address byte).

DEPOL—Driver Enable Polarity

0 = DE signal is Active High.

1 = DE signal is Active Low.

BRGCTL—Baud Rate Control

This bit causes an alternate UART behavior depending on the value of the REN bit in the UART Control 0 Register.

When the UART receiver is **not** enabled (REN=0), this bit determines whether the Baud Rate Generator issues interrupts.

0 = Reads from the Baud Rate High and Low Byte registers return the BRG Reload Value

1 = The Baud Rate Generator generates a receive interrupt when it counts down to 0.

Reads from the Baud Rate High and Low Byte registers return the current BRG count value.

When the UART receiver is enabled (REN=1), this bit allows reads from the Baud Rate Registers to return the BRG count value instead of the Reload Value.

0 = Reads from the Baud Rate High and Low Byte registers return the BRG Reload Value.

1 = Reads from the Baud Rate High and Low Byte registers return the current BRG count value. Unlike the Timers, there is no mechanism to latch the Low Byte when the High Byte is read.

$\overline{\text{RDAIRQ}}$ —Receive Data Interrupt Enable

0 = Received data and receiver errors generates an interrupt request to the Interrupt Controller.

1 = Received data does not generate an interrupt request to the Interrupt Controller. Only receiver errors generate an interrupt request.

IREN—Infrared Encoder/Decoder Enable

0 = Infrared Encoder/Decoder is disabled. UART operates normally.

1 = Infrared Encoder/Decoder is enabled. The UART transmits and receives data through the Infrared Encoder/Decoder.

## UART Status 0 Register

The UART Status 0 (UxSTAT0) and Status 1 (UxSTAT1) registers (Table 63 and Table 64) identify the current UART operating configuration and status.

**Table 63. UART Status 0 Register (U0STAT0)**

BITS	7	6	5	4	3	2	1	0
FIELD	RDA	PE	OE	FE	BRKD	TDRE	TXE	CTS
RESET	0	0	0	0	0	1	1	X
R/W	R	R	R	R	R	R	R	R
ADDR	F41H							

RDA—Receive Data Available

This bit indicates that the UART Receive Data register has received data. Reading the UART Receive Data register clears this bit.

0 = The UART Receive Data register is empty.

1 = There is a byte in the UART Receive Data register.

PE—Parity Error

This bit indicates that a parity error has occurred. Reading the UART Receive Data register clears this bit.

0 = No parity error has occurred.

1 = A parity error has occurred.

OE—Overrun Error

This bit indicates that an overrun error has occurred. An overrun occurs when new data is received and the UART Receive Data register has not been read. If the RDA bit is reset to 0, reading the UART Receive Data register clears this bit.

0 = No overrun error occurred.

1 = An overrun error occurred.

FE—Framing Error

This bit indicates that a framing error (no Stop bit following data reception) was detected. Reading the UART Receive Data register clears this bit.

0 = No framing error occurred.

1 = A framing error occurred.

**BRKD**—Break Detect

This bit indicates that a break occurred. If the data bits, parity/multiprocessor bit, and Stop bit(s) are all 0s this bit is set to 1. Reading the UART Receive Data register clears this bit.

0 = No break occurred.

1 = A break occurred.

**TDRE**—Transmitter Data Register Empty

This bit indicates that the UART Transmit Data register is empty and ready for additional data. Writing to the UART Transmit Data register resets this bit.

0 = Do not write to the UART Transmit Data register.

1 = The UART Transmit Data register is ready to receive an additional byte to be transmitted.

**TXE**—Transmitter Empty

This bit indicates that the transmit shift register is empty and character transmission is finished.

0 = Data is currently transmitting.

1 = Transmission is complete.

**CTS**— $\overline{\text{CTS}}$  signal

When this bit is read it returns the level of the  $\overline{\text{CTS}}$  signal. This signal is active Low.

## UART Status 1 Register

This register contains multiprocessor control and status bits.

**Table 64. UART Status 1 Register (U0STAT1)**

BITS	7	6	5	4	3	2	1	0
FIELD	Reserved						NEWFRM	MPRX
RESET	0	0	0	0	0	0	0	0
R/W	R	R	R	R	R/W	R/W	R	R
ADDR	F44H							

Reserved—Must be 0.

**NEWFRM**—Status bit denoting the start of a new frame. Reading the UART Receive Data register resets this bit to 0.

0 = The current byte is not the first data byte of a new frame.

1 = The current byte is the first data byte of a new frame.

MPRX—Multiprocessor Receive

Returns the value of the most recent multiprocessor bit received. Reading from the UART Receive Data register resets this bit to 0.

## UART Transmit Data Register

Data bytes written to the UART Transmit Data (UxTXD) register (Table 65) are shifted out on the TXD<sub>x</sub> pin. The Write-only UART Transmit Data register shares a Register File address with the read-only UART Receive Data register.

**Table 65. UART Transmit Data Register (U0TXD)**

BITS	7	6	5	4	3	2	1	0
FIELD	TXD							
RESET	X	X	X	X	X	X	X	X
R/W	W	W	W	W	W	W	W	W
ADDR	F40H							

TXD—Transmit Data

UART transmitter data byte to be shifted out through the TXD<sub>x</sub> pin.

## UART Receive Data Register

Data bytes received through the RXD<sub>x</sub> pin are stored in the UART Receive Data (UxRXD) register (Table 66). The read-only UART Receive Data register shares a Register File address with the Write-only UART Transmit Data register.

**Table 66. UART Receive Data Register (U0RXD)**

BITS	7	6	5	4	3	2	1	0
FIELD	RXD							
RESET	X	X	X	X	X	X	X	X
R/W	R	R	R	R	R	R	R	R
ADDR	F40H							
X = Undefined.								

RXD—Receive Data

UART receiver data byte from the RXD<sub>x</sub> pin

## UART Address Compare Register

The UART Address Compare (UxADDR) register stores the multi-node network address of the UART (see [Table 67](#)). When the MPMD[1] bit of UART Control Register 0 is set, all incoming address bytes are compared to the value stored in the Address Compare register. Receive interrupts and RDA assertions only occur in the event of a match.

**Table 67. UART Address Compare Register (U0ADDR)**

BITS	7	6	5	4	3	2	1	0
FIELD	COMP_ADDR							
RESET	0	0	0	0	0	0	0	0
R/W	R/W	R/W	R/W	R/W	R/W	R/W	R/W	R/W
ADDR	F45H							

COMP\_ADDR—Compare Address  
This 8-bit value is compared to incoming address bytes.

## UART Baud Rate High and Low Byte Registers

The UART Baud Rate High (UxBRH) and Low Byte (UxBRL) registers ([Table 68](#) and [Table 69](#)) combine to create a 16-bit baud rate divisor value (BRG[15:0]) that sets the data transmission rate (baud rate) of the UART.

**Table 68. UART Baud Rate High Byte Register (U0BRH)**

BITS	7	6	5	4	3	2	1	0
FIELD	BRH							
RESET	1	1	1	1	1	1	1	1
R/W	R/W	R/W	R/W	R/W	R/W	R/W	R/W	R/W
ADDR	F46H							

**Table 69. UART Baud Rate Low Byte Register (U0BRL)**

BITS	7	6	5	4	3	2	1	0
FIELD	BRL							
RESET	1	1	1	1	1	1	1	1
R/W	R/W	R/W	R/W	R/W	R/W	R/W	R/W	R/W
ADDR	F47H							

The UART data rate is calculated using the following equation:

$$\text{UART Baud Rate (bits/s)} = \frac{\text{System Clock Frequency (Hz)}}{16 \times \text{UART Baud Rate Divisor Value}}$$

For a given UART data rate, calculate the integer baud rate divisor value using the following equation:

$$\text{UART Baud Rate Divisor Value (BRG)} = \text{Round}\left(\frac{\text{System Clock Frequency (Hz)}}{16 \times \text{UART Data Rate (bits/s)}}\right)$$

The baud rate error relative to the acceptable baud rate is calculated using the following equation:

$$\text{UART Baud Rate Error (\%)} = 100 \times \left(\frac{\text{Actual Data Rate} - \text{Desired Data Rate}}{\text{Desired Data Rate}}\right)$$

For reliable communication, the UART baud rate error must never exceed 5 percent.

[Table 70](#) provides information on the data rate errors for popular baud rates and commonly used crystal oscillator frequencies.

**Table 70. UART Baud Rates**

10.0 MHz System Clock				5.5296 MHz System Clock			
Acceptable Rate (kHz)	BRG Divisor (Decimal)	Actual Rate (kHz)	Error (%)	Acceptable Rate (kHz)	BRG Divisor (Decimal)	Actual Rate (kHz)	Error (%)
1250.0	N/A	N/A	N/A	1250.0	N/A	N/A	N/A
625.0	1	625.0	0.00	625.0	N/A	N/A	N/A
250.0	3	208.33	-16.67	250.0	1	345.6	38.24
115.2	5	125.0	8.51	115.2	3	115.2	0.00
57.6	11	56.8	-1.36	57.6	6	57.6	0.00
38.4	16	39.1	1.73	38.4	9	38.4	0.00
19.2	33	18.9	0.16	19.2	18	19.2	0.00
9.60	65	9.62	0.16	9.60	36	9.60	0.00
4.80	130	4.81	0.16	4.80	72	4.80	0.00
2.40	260	2.40	-0.03	2.40	144	2.40	0.00
1.20	521	1.20	-0.03	1.20	288	1.20	0.00
0.60	1042	0.60	-0.03	0.60	576	0.60	0.00
0.30	2083	0.30	0.2	0.30	1152	0.30	0.00



**Table 70. UART Baud Rates (Continued)**

3.579545 MHz System Clock			
Acceptable Rate (kHz)	BRG Divisor (Decimal)	Actual Rate (kHz)	Error (%)
1250.0	N/A	N/A	N/A
625.0	N/A	N/A	N/A
250.0	1	223.72	-10.51
115.2	2	111.9	-2.90
57.6	4	55.9	-2.90
38.4	6	37.3	-2.90
19.2	12	18.6	-2.90
9.60	23	9.73	1.32
4.80	47	4.76	-0.83
2.40	93	2.41	0.23
1.20	186	1.20	0.23
0.60	373	0.60	-0.04
0.30	746	0.30	-0.04

1.8432 MHz System Clock			
Acceptable Rate (kHz)	BRG Divisor (Decimal)	Actual Rate (kHz)	Error (%)
1250.0	N/A	N/A	N/A
625.0	N/A	N/A	N/A
250.0	N/A	N/A	N/A
115.2	1	115.2	0.00
57.6	2	57.6	0.00
38.4	3	38.4	0.00
19.2	6	19.2	0.00
9.60	12	9.60	0.00
4.80	24	4.80	0.00
2.40	48	2.40	0.00
1.20	96	1.20	0.00
0.60	192	0.60	0.00
0.30	384	0.30	0.00

# Infrared Encoder/Decoder

The Z8 Encore! XP<sup>®</sup> F082A Series products contain a fully-functional, high-performance UART to Infrared Encoder/Decoder (Endec). The Infrared Endec is integrated with an on-chip UART to allow easy communication between the Z8 Encore! and IrDA Physical Layer Specification, Version 1.3-compliant infrared transceivers. Infrared communication provides secure, reliable, low-cost, point-to-point communication between PCs, PDAs, cell phones, printers, and other infrared enabled devices.

## Architecture

Figure 16 displays the architecture of the Infrared Endec.

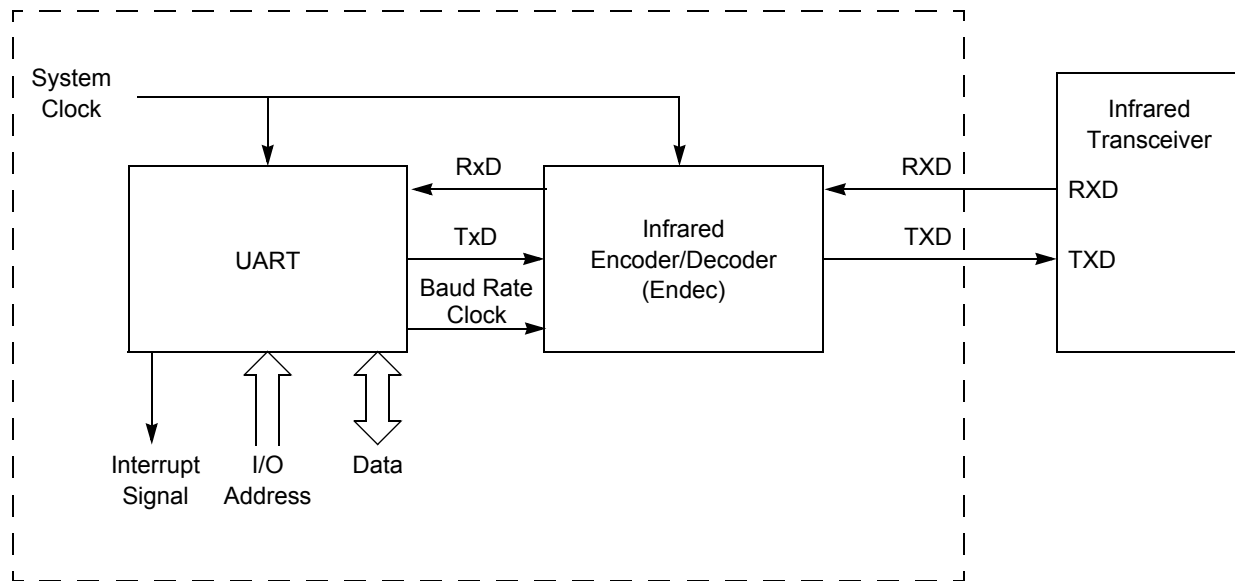

Figure 16. Infrared Data Communication System Block Diagram

## Operation

When the Infrared Endec is enabled, the transmit data from the associated on-chip UART is encoded as digital signals in accordance with the IrDA standard and output to the infrared transceiver through the TXD pin. Likewise, data received from the infrared transceiver is passed to the Infrared Endec through the RXD pin, decoded by the Infrared



Endec, and passed to the UART. Communication is half-duplex, which means simultaneous data transmission and reception is not allowed.

The baud rate is set by the UART's Baud Rate Generator and supports IrDA standard baud rates from 9600 baud to 115.2 kbaud. Higher baud rates are possible, but do not meet IrDA specifications. The UART must be enabled to use the Infrared Endec. The Infrared Endec data rate is calculated using the following equation:

$$\text{Infrared Data Rate (bits/s)} = \frac{\text{System Clock Frequency (Hz)}}{16 \times \text{UART Baud Rate Divisor Value}}$$

### Transmitting IrDA Data

The data to be transmitted using the infrared transceiver is first sent to the UART. The UART's transmit signal (TXD) and baud rate clock are used by the IrDA to generate the modulation signal (IR\_TXD) that drives the infrared transceiver. Each UART/Infrared data bit is 16 clocks wide. If the data to be transmitted is 1, the IR\_TXD signal remains low for the full 16 clock period. If the data to be transmitted is 0, the transmitter first outputs a 7 clock low period, followed by a 3 clock high pulse. Finally, a 6 clock low pulse is output to complete the full 16 clock data period. [Figure 17](#) displays IrDA data transmission. When the Infrared Endec is enabled, the UART's TXD signal is internal to the Z8 Encore! XP<sup>®</sup> F082A Series products while the IR\_TXD signal is output through the TXD pin.

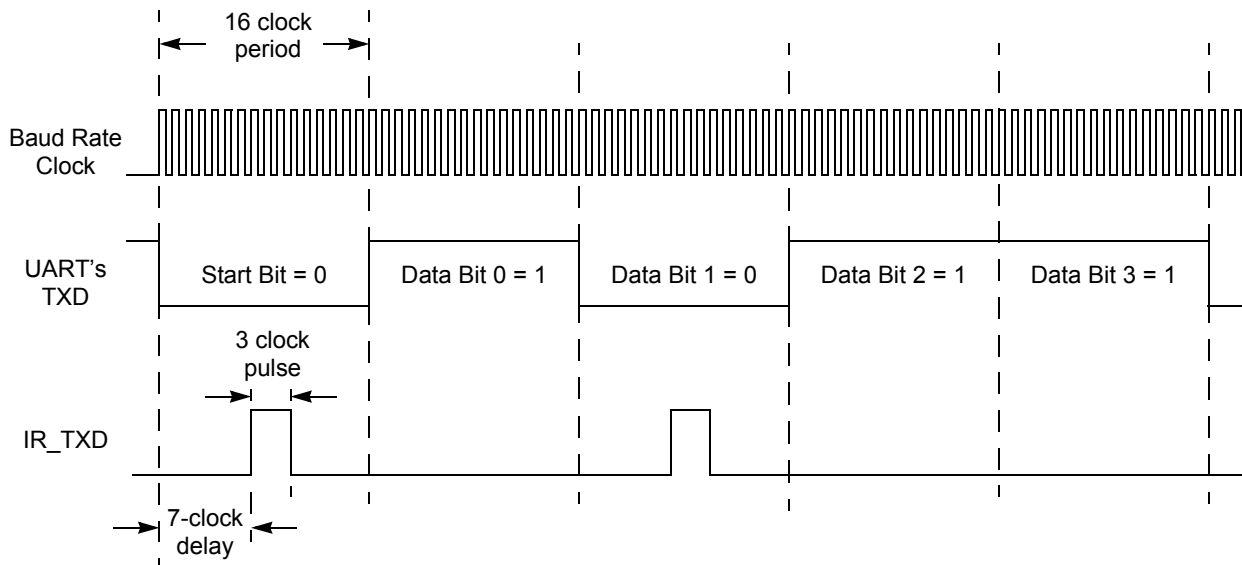

**Figure 17. Infrared Data Transmission**

## Receiving IrDA Data

Data received from the infrared transceiver using the IR\_RXD signal through the RXD pin is decoded by the Infrared Endec and passed to the UART. The UART's baud rate clock is used by the Infrared Endec to generate the demodulated signal (RXD) that drives the UART. Each UART/Infrared data bit is 16-clocks wide. Figure 18 displays data reception. When the Infrared Endec is enabled, the UART's RXD signal is internal to the Z8 Encore! XP<sup>®</sup> F082A Series products while the IR\_RXD signal is received through the RXD pin.

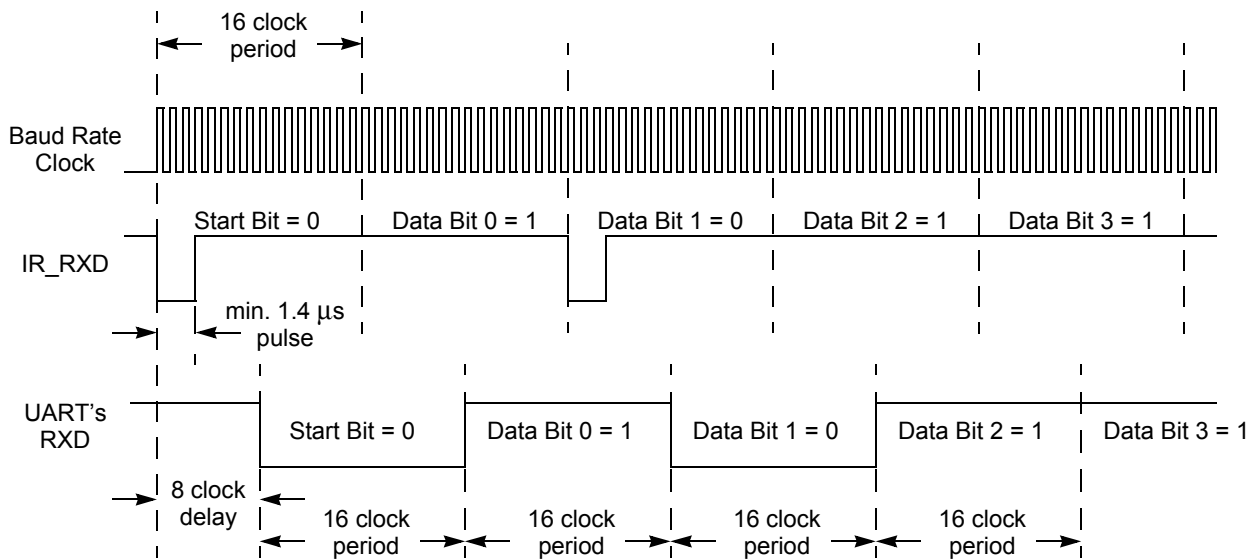

Figure 18. IrDA Data Reception

### Infrared Data Reception



**Caution:** The system clock frequency must be at least 1.0 MHz to ensure proper reception of the 1.4 μs minimum width pulses allowed by the IrDA standard.

### Endec Receiver Synchronization

The IrDA receiver uses a local baud rate clock counter (0 to 15 clock periods) to generate an input stream for the UART and to create a sampling window for detection of incoming pulses. The generated UART input (UART RXD) is delayed by 8 baud rate clock periods with respect to the incoming IrDA data stream. When a falling edge in the input data stream is detected, the Endec counter is reset. When the count reaches a value of 8, the UART RXD value is updated to reflect the value of the decoded data. When the count reaches 12 baud clock periods, the sampling window for the next incoming pulse opens. The window remains open until the count again reaches 8 (that is, 24 baud clock periods since the previous pulse was detected), giving the Endec a sampling window of minus four

baud rate clocks to plus eight baud rate clocks around the expected time of an incoming pulse. If an incoming pulse is detected inside this window this process is repeated. If the incoming data is a logical 1 (no pulse), the Endec returns to the initial state and waits for the next falling edge. As each falling edge is detected, the Endec clock counter is reset, resynchronizing the Endec to the incoming signal, allowing the Endec to tolerate jitter and baud rate errors in the incoming datastream. Resynchronizing the Endec does not alter the operation of the UART, which ultimately receives the data. The UART is only synchronized to the incoming data stream when a Start bit is received.

## Infrared Encoder/Decoder Control Register Definitions

All Infrared Endec configuration and status information is set by the UART control registers as defined in [Universal Asynchronous Receiver/Transmitter](#) on page 97.



**Caution:** *To prevent spurious signals during IrDA data transmission, set the IREN bit in the UART Control 1 register to 1 to enable the Infrared Encoder/Decoder before enabling the GPIO Port alternate function for the corresponding pin.*

# Analog-to-Digital Converter

The analog-to-digital converter (ADC) converts an analog input signal to its digital representation. The features of this sigma-delta ADC include:

- 11-bit resolution in DIFFERENTIAL mode.
- 10-bit resolution in SINGLE-ENDED mode.
- Eight single-ended analog input sources are multiplexed with general-purpose I/O ports.
- 9<sup>th</sup> analog input obtained from temperature sensor peripheral.
- 11 pairs of differential inputs also multiplexed with general-purpose I/O ports.
- Low-power operational amplifier (LPO).
- Interrupt on conversion complete.
- Bandgap generated internal voltage reference with two selectable levels.
- Manual in-circuit calibration is possible employing user code (offset calibration).
- Factory calibrated for in-circuit error compensation.

## Architecture

[Figure 19](#) displays the major functional blocks of the ADC. An analog multiplexer network selects the ADC input from the available analog pins, ANA0 through ANA7.

The input stage of the ADC allows both differential gain and buffering. The following input options are available:

- Unbuffered input (SINGLE-ENDED and DIFFERENTIAL modes).
- Buffered input with unity gain (SINGLE-ENDED and DIFFERENTIAL modes).
- LPO output with full pin access to the feedback path.

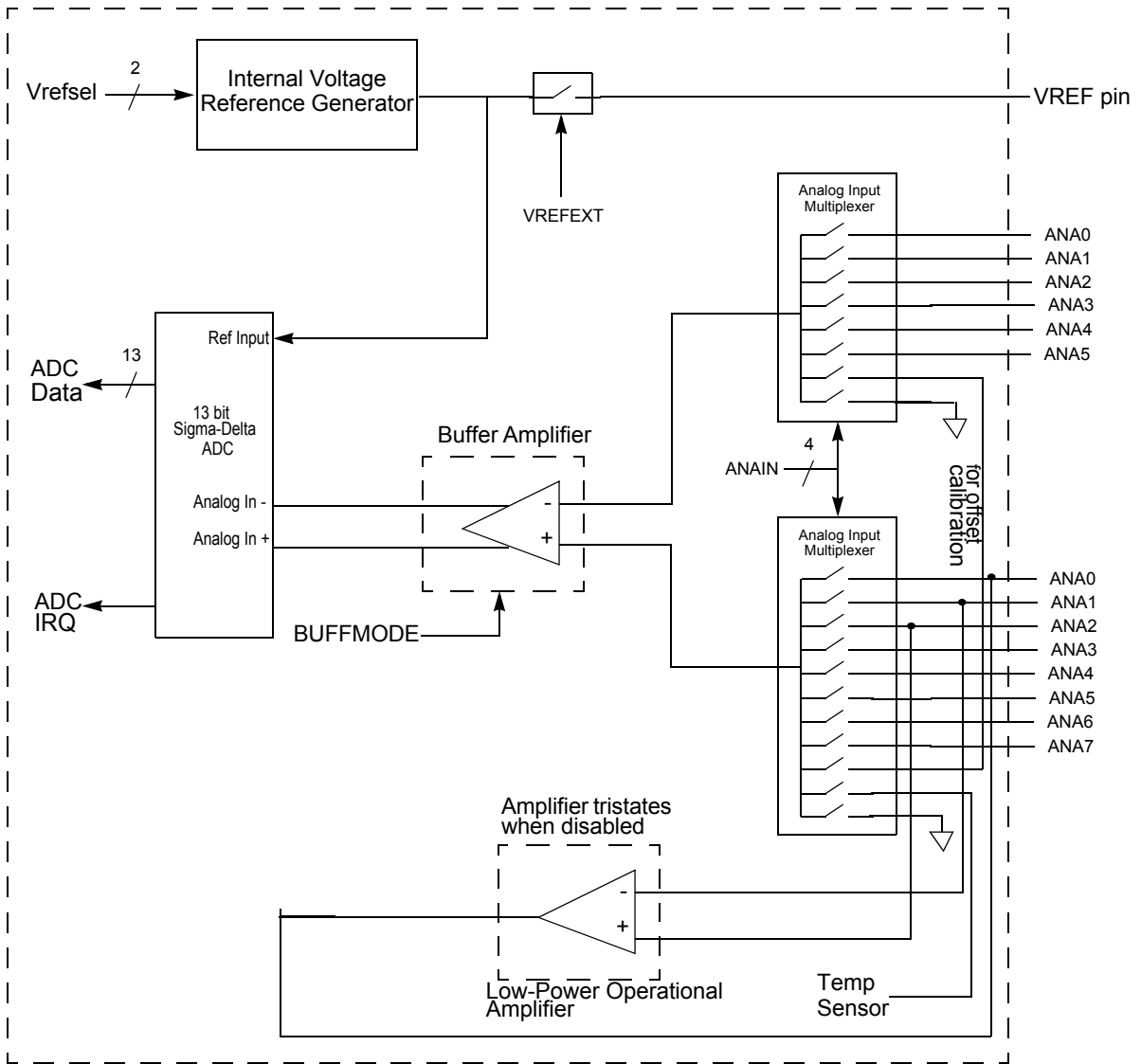

Figure 19. Analog-to-Digital Converter Block Diagram

## Operation

### Data Format

In both SINGLE-ENDED and DIFFERENTIAL modes, the effective output of the ADC is an 11-bit, signed, two's complement digital value. In DIFFERENTIAL mode, the ADC

can output values across the entire 11-bit range, from -1024 to +1023. In SINGLE-ENDED mode, the output generally ranges from 0 to +1023, but offset errors can cause small negative values.

The ADC registers actually return 13 bits of data, but the two LSBs are intended for compensation use only. When the software compensation routine is performed on the 13 bit raw ADC value, two bits of resolution are lost because of a rounding error. As a result, the final value is an 11-bit number.

## Hardware Overflow

When the hardware overflow bit (OVF) is set in ADC Data Low Byte (ADCD\_L) register, all other data bits are invalid. The hardware overflow bit is set for values greater than  $V_{ref}$  and less than  $-V_{ref}$  (DIFFERENTIAL mode).

## Automatic Powerdown

If the ADC is idle (no conversions in progress) for 160 consecutive system clock cycles, portions of the ADC are automatically powered down. From this powerdown state, the ADC requires 40 system clock cycles to power up. The ADC powers up when a conversion is requested by the ADC Control register.

## Single-Shot Conversion

When configured for single-shot conversion, the ADC performs a single analog-to-digital conversion on the selected analog input channel. After completion of the conversion, the ADC shuts down. Follow the steps below for setting up the ADC and initiating a single-shot conversion:

1. Enable the desired analog inputs by configuring the general-purpose I/O pins for alternate analog function. This configuration disables the digital input and output drivers.
2. Write the [ADC Control/Status Register 1](#) to configure the ADC.
  - Write to BUFMODE [2 : 0] to select SINGLE-ENDED or DIFFERENTIAL mode, as well as unbuffered or buffered mode.
  - Write the REFSELH bit of the pair {REFSELH, REFSELL} to select the internal voltage reference level or to disable the internal reference. The REFSELL bit is contained in the [ADC Control Register 0](#).
3. Write to the [ADC Control Register 0](#) to configure the ADC and begin the conversion. The bit fields in the ADC Control register can be written simultaneously (the ADC can be configured and enabled with the same write instruction):
  - Write to the ANAIN [3 : 0] field to select from the available analog input sources (different input pins available depending on the device).
  - Clear CONT to 0 to select a single-shot conversion.

- If the internal voltage reference must be output to a pin, set the REFEXT bit to 1. The internal voltage reference must be enabled in this case.
  - Write the REFSELL bit of the pair {REFSELH, REFSELL} to select the internal voltage reference level or to disable the internal reference. The REFSELH bit is contained in the [ADC Control/Status Register 1](#).
  - Set CEN to 1 to start the conversion.
4. CEN remains 1 while the conversion is in progress. A single-shot conversion requires 5129 system clock cycles to complete. If a single-shot conversion is requested from an ADC powered-down state, the ADC uses 40 additional clock cycles to power up before beginning the 5129 cycle conversion.
  5. When the conversion is complete, the ADC control logic performs the following operations:
    - 13-bit two's-complement result written to {ADCD\_H[7:0], ADCD\_L[7:3]}.
    - Sends an interrupt request to the Interrupt Controller denoting conversion complete.
    - CEN resets to 0 to indicate the conversion is complete.
  6. If the ADC remains idle for 160 consecutive system clock cycles, it is automatically powered-down.

## Continuous Conversion

When configured for continuous conversion, the ADC continuously performs an analog-to-digital conversion on the selected analog input. Each new data value over-writes the previous value stored in the ADC Data registers. An interrupt is generated after each conversion.



**Caution:** *In CONTINUOUS mode, ADC updates are limited by the input signal bandwidth of the ADC and the latency of the ADC and its digital filter. Step changes at the input are not immediately detected at the next output from the ADC. The response of the ADC (in all modes) is limited by the input signal bandwidth and the latency.*

Follow the steps below for setting up the ADC and initiating continuous conversion:

1. Enable the desired analog input by configuring the general-purpose I/O pins for alternate function. This action disables the digital input and output driver.
2. Write the [ADC Control/Status Register 1](#) to configure the ADC.
  - Write to BUFMODE[2:0] to select SINGLE-ENDED or DIFFERENTIAL mode, as well as unbuffered or buffered mode.
  - Write the REFSELH bit of the pair {REFSELH, REFSELL} to select the internal voltage reference level or to disable the internal reference. The REFSELL bit is contained in the [ADC Control Register 0](#).

3. Write to the [ADC Control Register 0](#) to configure the ADC for continuous conversion. The bit fields in the ADC Control register may be written simultaneously:
  - Write to the `ANAIN[3:0]` field to select from the available analog input sources (different input pins available depending on the device).
  - Set `CONT` to 1 to select continuous conversion.
  - If the internal `VREF` must be output to a pin, set the `REFEXT` bit to 1. The internal voltage reference must be enabled in this case.
  - Write the `REFSELL` bit of the pair `{REFSELH, REFSELL}` to select the internal voltage reference level or to disable the internal reference. The `REFSELH` bit is contained in [ADC Control/Status Register 1](#).
  - Set `CEN` to 1 to start the conversions.
4. When the first conversion in continuous operation is complete (after 5129 system clock cycles, plus the 40 cycles for power-up, if necessary), the ADC control logic performs the following operations:
  - `CEN` resets to 0 to indicate the first conversion is complete. `CEN` remains 0 for all subsequent conversions in continuous operation.
  - An interrupt request is sent to the Interrupt Controller to indicate the conversion is complete.
5. The ADC writes a new data result every 256 system clock cycles. For each completed conversion, the ADC control logic performs the following operations:
  - Writes the 13-bit two's complement result to `{ADCD_H[7:0], ADCD_L[7:3]}`.
  - Sends an interrupt request to the Interrupt Controller denoting conversion complete.
6. To disable continuous conversion, clear the `CONT` bit in the ADC Control Register to 0.

## Interrupts

The ADC is able to interrupt the CPU when a conversion has been completed. When the ADC is disabled, no new interrupts are asserted; however, an interrupt pending when the ADC is disabled is not cleared.

## Calibration and Compensation

The Z8 Encore! XP<sup>®</sup> F082A Series ADC is factory calibrated for offset error and gain error, with the compensation data stored in Flash memory. Alternatively, you can perform your own calibration, storing the values into Flash themselves. Thirdly, the user code can perform a manual offset calibration during DIFFERENTIAL mode operation.



## Factory Calibration

Devices that have been factory calibrated contain 30 bytes of calibration data in the Flash option bit space. This data consists of 3 bytes for each input mode, one for offset and two for gain correction. For a list of input modes for which calibration data exists, see [Zilog Calibration Data](#) on page 161.

## User Calibration

If you have precision references available, its own external calibration can be performed using any input modes. This calibration data takes into account buffer offset and non-linearity, so it is recommended that this calibration be performed separately for each of the ADC input modes planned for use.

## Manual Offset Calibration

When uncalibrated, the ADC has significant offset (see [Table 135](#) on page 231). Subsequently, manual offset calibration capability is built into the block. When the [ADC Control Register 0](#) sets the input mode ( $ANA_{IN}[2:0]$ ) to MANUAL OFFSET CALIBRATION mode, the differential inputs to the ADC are shorted together by an internal switch. Reading the ADC value at this point produces 0 in an ideal system. The value actually read is the ADC offset. This value can be stored in non-volatile memory (see [Non-Volatile Data Storage](#) on page 169) and accessed by user code to compensate for the input offset error. There is no provision for manual gain calibration.

## Software Compensation Procedure Using Factory Calibration Data

The value read from the ADC high and low byte registers is uncompensated. The user mode software must apply gain and offset correction to this uncompensated value for maximum accuracy. The following equation yields the compensated value:

$$ADC_{comp} = (ADC_{uncomp} - OFFCAL) + ((ADC_{uncomp} - OFFCAL) \times GAINCAL) / 2^{16}$$

where GAINCAL is the gain calibration value, OFFCAL is the offset calibration value and  $ADC_{uncomp}$  is the uncompensated value read from the ADC. All values are in two's complement format.

► **Note:** *The offset compensation is performed first, followed by the gain compensation. One bit of resolution is lost because of rounding on both the offset and gain computations. As a result the ADC registers read back 13 bits: 1 sign bit, two calibration bits lost to rounding and 10 data bits.*

*Also note that in the second term, the multiplication must be performed before the division by  $2^{16}$ . Otherwise, the second term incorrectly evaluates to zero.*



**Caution:** *Although the ADC can be used without the gain and offset compensation, it does exhibit non-unity gain. Designing the ADC with sub-unity gain reduces noise across the ADC range but requires the ADC results to be scaled by a factor of 8/7.*

### ADC Compensation Details

High efficiency assembly code that performs this compensation is available for download on [www.zilog.com](http://www.zilog.com). The following is a bit-specific description of the ADC compensation process used by this code.

The following data bit definitions are used:

0-9, a-f = bit indices in hexadecimal

s = sign bit

v = overflow bit

- = unused

#### Input Data

MSB	LSB	
s b a 9 8 7 6 5	4 3 2 1 0 - - v	(ADC)      ADC Output Word; if v = 1, the data is invalid

s 6 5 4 3 2 1 0	Offset Correction Byte
-----------------	------------------------

s s s s s 7 6 5	4 3 2 1 0 0 0 0	(Offset)	Offset Byte shifted to align with ADC data
-----------------	-----------------	----------	---

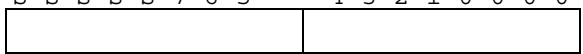

s e d c b a 9 8	7 6 5 4 3 2 1 0	(Gain)	Gain Correction Word
-----------------	-----------------	--------	----------------------

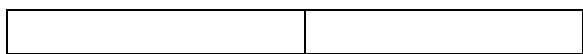
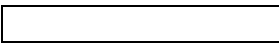

Compensation Steps:

1. Correct for Offset

ADC MSB	ADC LSB
---------	---------

-

Offset MSB	Offset LSB
------------	------------

=

#1 MSB	#1 LSB
--------	--------

2. Take absolute value of the offset corrected ADC value *if negative*—the gain correction factor is computed assuming positive numbers, with sign restoration afterward.

#2 MSB	#2 LSB
--------	--------

Also take absolute value of the gain correction word *if negative*.

AGain MSB	AGain LSB
-----------	-----------

3. Multiply by Gain Correction Word. If in DIFFERENTIAL mode, there are two gain correction values: one for positive ADC values, another for negative ADC values. Based on the sign of #2, use the appropriate Gain Correction Word.

#2 MSB	#2 LSB
--------	--------

\*

AGain MSB	AGain LSB
-----------	-----------

=

#3	#3	#3	#3
----	----	----	----

4. Round the result and discard the least significant two bytes (this is equivalent to dividing by  $2^{16}$ ).

#3	#3	#3	#3
----	----	----	----

-

0x00	0x00	0x80	0x00
------	------	------	------

=

#4 MSB	#4 LSB
--------	--------

5. Determine sign of the gain correction factor using the sign bits from [Step 2](#). If the offset corrected ADC value AND the gain correction word have the same sign, then the factor is positive and is left unchanged. If they have differing signs, then the factor is negative and must be multiplied by -1.

#5 MSB	#5 LSB
--------	--------

6. Add the gain correction factor to the original offset corrected value.

#5 MSB	#5 LSB
--------	--------

+

#1 MSB	#1 LSB
--------	--------

=

#6 MSB	#6 LSB
--------	--------

7. Shift the result to the right, using the sign bit determined in [Step 1](#). This allows for the detection of computational overflow.

S->	#6 MSB	#6 LSB
-----	--------	--------

### Output Data

The following is the output format of the corrected ADC value.

MSB	LSB
s v b a 9 8 7 6	5 4 3 2 1 0 - -

The overflow bit in the corrected output indicates that the computed value was greater than the maximum logical value (+1023) or less than the minimum logical value (-1024). Unlike the hardware overflow bit, this is not a simple binary Flag. For a normal sample (non-overflow), the sign and the overflow bit matches. If the sign bit and overflow bit do not match, a computational overflow has occurred.

### Input Buffer Stage

Many applications require the measurement of an input voltage source with a high output impedance. This ADC provides a buffered input for such situations. The drawback of the buffered input is a limitation of the input range. When using unity gain buffered mode, the input signal must be prevented from coming too close to either  $V_{SS}$  or  $V_{DD}$ . See [Table 135](#) on page 231 for details.

This condition applies only to the input voltage level (with respect to ground) of each differential input signal. The actual differential input voltage magnitude may be less than 300 mV.

The input range of the unbuffered ADC swings from  $V_{SS}$  to  $V_{DD}$ . Input signals smaller than 300 mV must use the unbuffered input mode. If these signals do not contain low output impedances, they might require off-chip buffering.

Signals outside the allowable input range can be used without instability or device damage. Any ADC readings made outside the input range are subject to greater inaccuracy than specified.

## ADC Control Register Definitions

### ADC Control Register 0

The ADC Control Register 0 (ADCCTL0) selects the analog input channel and initiates the analog-to-digital conversion. It also selects the voltage reference configuration.

**Table 71. ADC Control Register 0 (ADCCTL0)**

BITS	7	6	5	4	3	2	1	0
FIELD	CEN	REFSELL	REFOUT	CONT	ANAIN[3:0]			
RESET	0	0	0	0	0	0	0	0
R/W	R/W	R/W	R/W	R/W	R/W	R/W	R/W	R/W
ADDR	F70H							

CEN—Conversion Enable

0 = Conversion is complete. Writing a 0 produces no effect. The ADC automatically clears this bit to 0 when a conversion is complete.

1 = Begin conversion. Writing a 1 to this bit starts a conversion. If a conversion is already in progress, the conversion restarts. This bit remains 1 until the conversion is complete.

REFSELL—Voltage Reference Level Select Low Bit; in conjunction with the High bit (REFSELH) in [ADC Control/Status Register 1](#), this determines the level of the internal voltage reference; the following details the effects of {REFSELH, REFSELL}; note that this reference is independent of the Comparator reference.

00= Internal Reference Disabled, reference comes from external pin

01= Internal Reference set to 1.0 V

10= Internal Reference set to 2.0 V (default)

11= Reserved

REFOUT—Internal Reference Output Enable

0 = Reference buffer is disabled; Vref pin is available for GPIO or analog functions

1 = The internal ADC reference is buffered and driven out to the Vref pin



**Warning:** *When the ADC is used with an external reference ({REFSELH,REFSELL}=00), the REFOUT bit must be set to 0.*

CONT

0 = Single-shot conversion. ADC data is output once at completion of the 5129 system clock cycles (measurements of the internal temperature sensor take twice as long)

1 = Continuous conversion. ADC data updated every 256 system clock cycles after an initial 5129 clock conversion (measurements of the internal temperature sensor take twice as long)

**ANAIN[3:0]**—Analog Input Select

These bits select the analog input for conversion. Not all Port pins in this list are available in all packages for the Z8 Encore! XP<sup>®</sup> F082A Series. For information on port pins available with each package style, see [Pin Description](#) on page 9. Do not enable unavailable analog inputs. Usage of these bits changes depending on the buffer mode selected in [ADC Control/Status Register 1](#).

For the reserved values, all input switches are disabled to avoid leakage or other undesirable operation. ADC samples taken with reserved bit settings are undefined.

**SINGLE-ENDED:**

0000 = ANA0 (transimpedance amp output when enabled)  
0001 = ANA1 (transimpedance amp inverting input)  
0010 = ANA2 (transimpedance amp non-inverting input)  
0011 = ANA3  
0100 = ANA4  
0101 = ANA5  
0110 = ANA6  
0111 = ANA7  
1000 = Reserved  
1001 = Reserved  
1010 = Reserved  
1011 = Reserved  
1100 = Hold transimpedance input nodes (ANA1 and ANA2) to ground.  
1101 = Reserved  
1110 = Temperature Sensor.  
1111 = Reserved.

**DIFFERENTIAL (non-inverting input and inverting input respectively):**

0000 = ANA0 and ANA1  
0001 = ANA2 and ANA3  
0010 = ANA4 and ANA5  
0011 = ANA1 and ANA0  
0100 = ANA3 and ANA2  
0101 = ANA5 and ANA4  
0110 = ANA6 and ANA5  
0111 = ANA0 and ANA2  
1000 = ANA0 and ANA3  
1001 = ANA0 and ANA4  
1010 = ANA0 and ANA5  
1011 = Reserved  
1100 = Reserved  
1101 = Reserved  
1110 = Reserved  
1111 = Manual Offset Calibration Mode

## ADC Control/Status Register 1

The ADC Control/Status Register 1 (ADCCTL1) configures the input buffer stage, enables the threshold interrupts and contains the status of both threshold triggers. It is also used to select the voltage reference configuration.

**Table 72. ADC Control/Status Register 1 (ADCCTL1)**

BITS	7	6	5	4	3	2	1	0
FIELD	REFSELH	Reserved				BUFMODE[2:0]		
RESET	1	0	0	0	0	0	0	0
R/W	R/W	R/W	R/W	R/W	R/W	R/W	R/W	R/W
ADDR	F71H							

REFSELH—Voltage Reference Level Select High Bit; in conjunction with the Low bit (REFSELL) in [ADC Control Register 0](#), this determines the level of the internal voltage reference; the following details the effects of {REFSELH, REFSELL}; this reference is independent of the Comparator reference.

00= Internal Reference Disabled, reference comes from external pin  
 01= Internal Reference set to 1.0 V  
 10= Internal Reference set to 2.0 V (default)  
 11= Reserved

BUFMODE[2:0] - Input Buffer Mode Select  
 000 = Single-ended, unbuffered input  
 001 = Single-ended, buffered input with unity gain  
 010 = Reserved  
 011 = Reserved  
 100 = Differential, unbuffered input  
 101 = Differential, buffered input with unity gain  
 110 = Reserved  
 111 = Reserved

## ADC Data High Byte Register

The ADC Data High Byte (ADC<sub>CD\_H</sub>) register contains the upper eight bits of the ADC output. The output is an 13-bit two's complement value. During a single-shot conversion, this value is invalid. Access to the ADC Data High Byte register is read-only. Reading the ADC Data High Byte register latches data in the ADC Low Bits register.

**Table 73. ADC Data High Byte Register (ADCD\_H)**

BITS	7	6	5	4	3	2	1	0
FIELD	ADCDH							
RESET	X	X	X	X	X	X	X	X
R/W	R	R	R	R	R	R	R	R
ADDR	F72H							
X = Undefined.								

**ADCDH—ADC Data High Byte**

This byte contains the upper eight bits of the ADC output. These bits are not valid during a single-shot conversion. During a continuous conversion, the most recent conversion output is held in this register. These bits are undefined after a Reset.

### ADC Data Low Byte Register

The ADC Data Low Byte (ADCD\_L) register contains the lower bits of the ADC output as well as an overflow status bit. The output is a 13-bit two’s complement value. During a single-shot conversion, this value is invalid. Access to the ADC Data Low Byte register is read-only. Reading the ADC Data High Byte register latches data in the ADC Low Bits register.

**Table 74. ADC Data Low Byte Register (ADCD\_L)**

BITS	7	6	5	4	3	2	1	0
FIELD	ADCDL					Reserved		OVF
RESET	X	X	X	X	X	X	X	X
R/W	R	R	R	R	R	R	R	R
ADDR	F73H							
X = Undefined.								

**ADCDL—ADC Data Low Bits**

These bits are the least significant five bits of the 13-bits of the ADC output. These bits are undefined after a Reset.

Reserved—Must be undefined.

**OVF—Overflow Status**

0= A hardware overflow did not occur in the ADC for the current sample.

1= A hardware overflow did occur in the ADC for the current sample, therefore the current sample is invalid.



# Low Power Operational Amplifier

## Overview

The LPO is a general-purpose low power operational amplifier. Each of the three ports of the amplifier is accessible from the package pins. The LPO contains only one pin configuration: ANA0 is the output/feedback node, ANA1 is the inverting input and ANA2 is the non-inverting input.

## Operation

To use the LPO, it must be enabled in the [Power Control Register 0 \(PWRCTL0\)](#). The default state of the LPO is OFF. To use the LPO, the LPO bit must be cleared, turning it ON ([Power Control Register 0 \(PWRCTL0\)](#) on page 35). When making normal ADC measurements on ANA0 (measurements not involving the LPO output), the LPO bit must be OFF. Turning the LPO bit ON interferes with normal ADC measurements.



**Warning:** *The LPO bit enables the amplifier even in STOP mode. If the amplifier is not required in STOP mode, disable it. Failing to perform this results in STOP mode currents higher than necessary.*

As with other ADC measurements, any pins used for analog purposes must be configured as such in the GPIO registers (see [Port A–D Alternate Function Sub-Registers](#) on page 47).

LPO output measurements are made on ANA0, as selected by the ANAIN[3:0] bits of [ADC Control Register 0](#). It is also possible to make single-ended measurements on ANA1 and ANA2 while the amplifier is enabled, which is often useful for determining offset conditions. Differential measurements between ANA0 and ANA2 may be useful for noise cancellation purposes.

If the LPO output is routed to the ADC, then the BUFFMODE[2:0] bits of [ADC Control/Status Register 1](#) must also be configured for unity-gain buffered operation. Sampling the LPO in an unbuffered mode is not recommended.

When either input is overdriven, the amplifier output saturates at the positive or negative supply voltage. No instability results.

# Comparator

The Z8 Encore! XP<sup>®</sup> F082A Series devices feature a general purpose comparator that compares two analog input signals. These analog signals may be external stimulus from a pin (CINP and/or CINN) or internally generated signals. Both a programmable voltage reference and the temperature sensor output voltage are available internally. The output is available as an interrupt source or can be routed to an external pin.

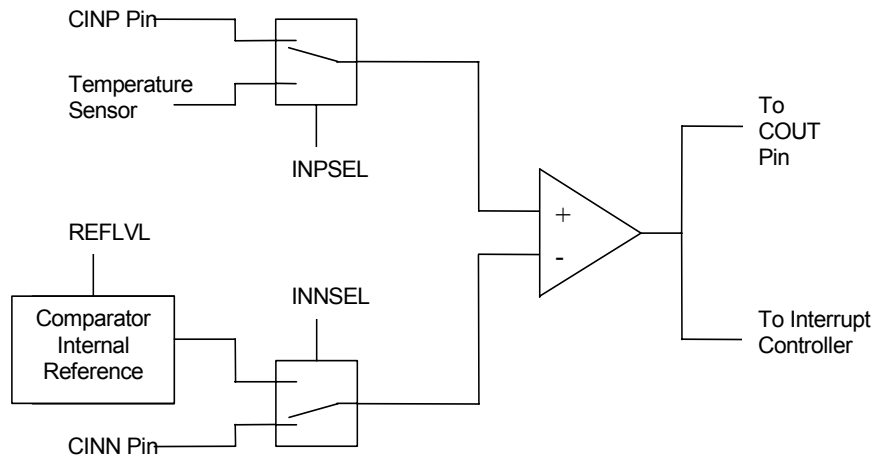

**Figure 20. Comparator Block Diagram**

## Operation

When the positive comparator input exceeds the negative input by more than the specified hysteresis, the output is a logic HIGH. When the negative input exceeds the positive by more than the hysteresis, the output is a logic LOW. Otherwise, the comparator output retains its present value. See [Table 137](#) on page 233 for details.

The comparator may be powered down to reduce supply current. See [Power Control Register 0](#) on page 34 for details.



**Caution:** *Because of the propagation delay of the comparator, it is not recommended to enable or reconfigure the comparator without first disabling interrupts and waiting for the comparator output to settle. Doing so can result in spurious interrupts. The following example describes how to safely enable the comparator:*

```
di
ld cmp0, r0 ; load some new configuration
nop
```

```
nop      ; wait for output to settle
clr irq0 ; clear any spurious interrupts pending
ei
```

## Comparator Control Register Definitions

### Comparator Control Register

The Comparator Control Register (CMP0) configures the comparator inputs and sets the value of the internal voltage reference.

**Table 75. Comparator Control Register (CMP0)**

BITS	7	6	5	4	3	2	1	0
FIELD	INPSEL	INNSEL	REFLVL				Reserved (20-/28-pin) REFLVL (8-pin)	
RESET	0	0	0	1	0	1	0	0
R/W	R/W	R/W	R/W	R/W	R/W	R/W	R/W	R/W
ADDR	F90H							

INPSEL—Signal Select for Positive Input

0 = GPIO pin used as positive comparator input

1 = temperature sensor used as positive comparator input

INNSEL—Signal Select for Negative Input

0 = internal reference disabled, GPIO pin used as negative comparator input

1 = internal reference enabled as negative comparator input

REFLVL—Internal Reference Voltage Level (this reference is independent of the ADC voltage reference). Note that the 8-pin devices contain two additional LSBs for increased resolution.

For 20-/28-pin devices:

0000 = 0.0 V

0001 = 0.2 V

0010 = 0.4 V

0011 = 0.6 V

0100 = 0.8 V

0101 = 1.0 V (Default)

0110 = 1.2 V

0111 = 1.4 V

1000 = 1.6 V

1001 = 1.8 V  
1010–1111 = Reserved

For 8-pin devices:

000000 = 0.00 V  
000001 = 0.05 V  
000010 = 0.10 V  
000011 = 0.15 V  
000100 = 0.20 V  
000101 = 0.25 V  
000110 = 0.30 V  
000111 = 0.35 V  
001000 = 0.40 V  
001001 = 0.45 V  
001010 = 0.50 V  
001011 = 0.55 V  
001100 = 0.60 V  
001101 = 0.65 V  
001110 = 0.70 V  
001111 = 0.75 V  
010000 = 0.80 V  
010001 = 0.85 V  
010010 = 0.90 V  
010011 = 0.95 V  
010100 = 1.00 V (Default)  
010101 = 1.05 V  
010110 = 1.10 V  
010111 = 1.15 V  
011000 = 1.20 V  
011001 = 1.25 V  
011010 = 1.30 V  
011011 = 1.35 V  
011100 = 1.40 V  
011101 = 1.45 V  
011110 = 1.50 V  
011111 = 1.55 V  
100000 = 1.60 V  
100001 = 1.65 V  
100010 = 1.70 V  
100011 = 1.75 V  
100100 = 1.80 V



# Temperature Sensor

The on-chip Temperature Sensor allows you to measure temperature on the die with either the on-board ADC or on-board comparator. This block is factory calibrated for in-circuit software correction. Uncalibrated accuracy is significantly worse, therefore the temperature sensor is not recommended for uncalibrated use.

## Temperature Sensor Operation

The on-chip temperature sensor is a Proportional to Absolute Temperature (PTAT) topology. A pair of Flash option bytes contain the calibration data. The temperature sensor can be disabled by a bit in the [Power Control Register 0](#) on page 34 to reduce power consumption.

The temperature sensor can be directly read by the ADC to determine the absolute value of its output. The temperature sensor output is also available as an input to the comparator for threshold type measurement determination. The accuracy of the sensor when used with the comparator is substantially less than when measured by the ADC.

If the temperature sensor is routed to the ADC, the ADC must be configured in unity-gain buffered mode (see [Input Buffer Stage](#) on page 129) The value read back from the ADC is a signed number, although it is always positive.

The sensor is factory-trimmed through the ADC using the external 2.0 V reference. Unless the sensor is re-trimmed for use with a different reference, it is most accurate when used with the external 2.0 V reference.

Because this sensor is an on-chip sensor it is recommended that the user account for the difference between ambient and die temperature when inferring ambient temperature conditions.

During normal operation, the die undergoes heating that causes a mismatch between the ambient temperature and that measured by the sensor. For best results, the Z8 Encore! XP<sup>®</sup> device must be placed into STOP mode for sufficient time such that the die and ambient temperatures converge (this time is dependent on the thermal design of the system). The temperature sensor measurement must then be made immediately after recovery from STOP mode.

The following equation defines the transfer function between the temperature sensor output voltage and the die temperature. This is needed for comparator threshold measurements.

$$V = 0.01 \times T + 0.65$$

where, T is the temperature in °C; V is the sensor output in volts.

Assuming a compensated ADC measurement, the following equation defines the relationship between the ADC reading and the die temperature:

$$T = (25/128) \times (\text{ADC} - \text{TSCAL}[11:2]) + 30$$

where, T is the temperature in C; ADC is the 10-bit compensated ADC value; and TSCAL is the temperature sensor calibration value, ignoring the two least significant bits of the 12-bit value.

See [Temperature Sensor Calibration Data](#) on page 164 for the location of TSCAL.

## Calibration

The temperature sensor undergoes calibration during the manufacturing process and is maximally accurate at 30 °C. Accuracy decreases as measured temperatures move further from the calibration point.

# Flash Memory

The products in the Z8 Encore! XP<sup>®</sup> F082A Series feature a non-volatile Flash memory of 8 KB (8192), 4 KB (4096), 2 KB (2048 bytes), or 1 KB (1024) with read/write/erase capability. The Flash Memory can be programmed and erased in-circuit by user code or through the On-Chip Debugger. The features include:

- User controlled read and write protect capability
- Sector-based write protection scheme
- Additional protection schemes against accidental program and erasure

## Architecture

The Flash memory array is arranged in pages with 512 bytes per page. The 512 byte page is the minimum Flash block size that can be erased. Each page is divided into 8 rows of 64 bytes.

For program or data protection, the Flash memory is also divided into sectors. In the Z8 Encore! XP F082A Series, these sectors are either 1024 bytes (in the 8 KB devices) or 512 bytes (all other memory sizes) in size. Page and sector sizes are not generally equal.

The first 2 bytes of the Flash Program memory are used as Flash Option Bits. For more information about their operation, see [Flash Option Bits](#) on page 153.

[Table 76](#) describes the Flash memory configuration for each device in the Z8 Encore! XP F082A Series. [Figure 21](#) displays the Flash memory arrangement.

**Table 76. Z8 Encore! XP F082A Series Flash Memory Configurations**

Part Number	Flash Size KB (Bytes)	Flash Pages	Program Memory Addresses	Flash Sector Size (Bytes)
Z8F08xA	8 (8192)	16	0000H–1FFFH	1024
Z8F04xA	4 (4096)	8	0000H–0FFFH	512
Z8F02xA	2 (2048)	4	0000H–07FFH	512
Z8F01xA	1 (1024)	2	0000H–03FFH	512



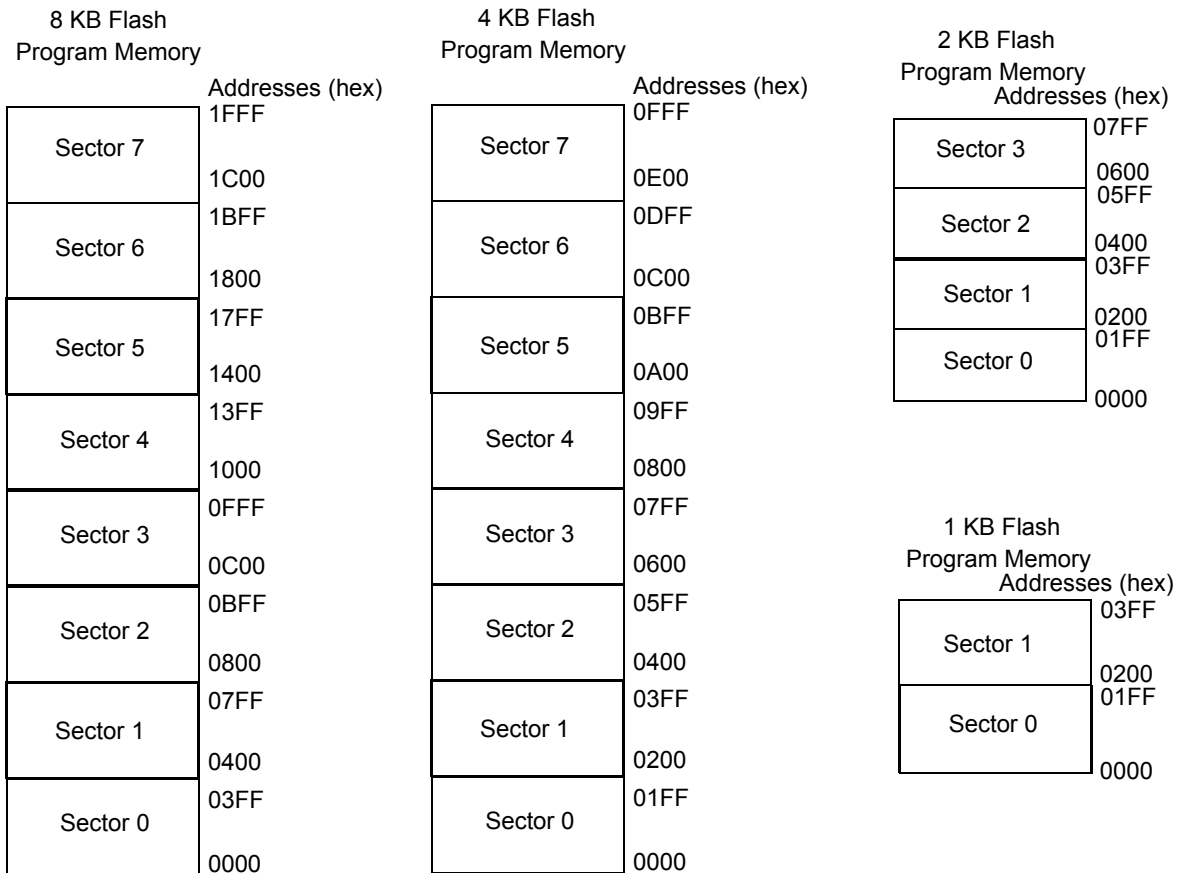

Figure 21. Flash Memory Arrangement

## Flash Information Area

The Flash information area is separate from Program Memory and is mapped to the address range FE00H to FFFFH. This area is readable but cannot be erased or overwritten. Factory trim values for the analog peripherals are stored here. Factory calibration data for the ADC is also stored here.

## Operation

The Flash Controller programs and erases Flash memory. The Flash Controller provides the proper Flash controls and timing for Byte Programming, Page Erase, and Mass Erase of Flash memory.

The Flash Controller contains several protection mechanisms to prevent accidental programming or erasure. These mechanisms operate on the page, sector and full-memory levels.

The Flow Chart in [Figure 22](#) displays basic Flash Controller operation. The following subsections provide details about the various operations (Lock, Unlock, Byte Programming, Page Protect, Page Unprotect, Page Select, Page Erase, and Mass Erase) displayed in [Figure 22](#).

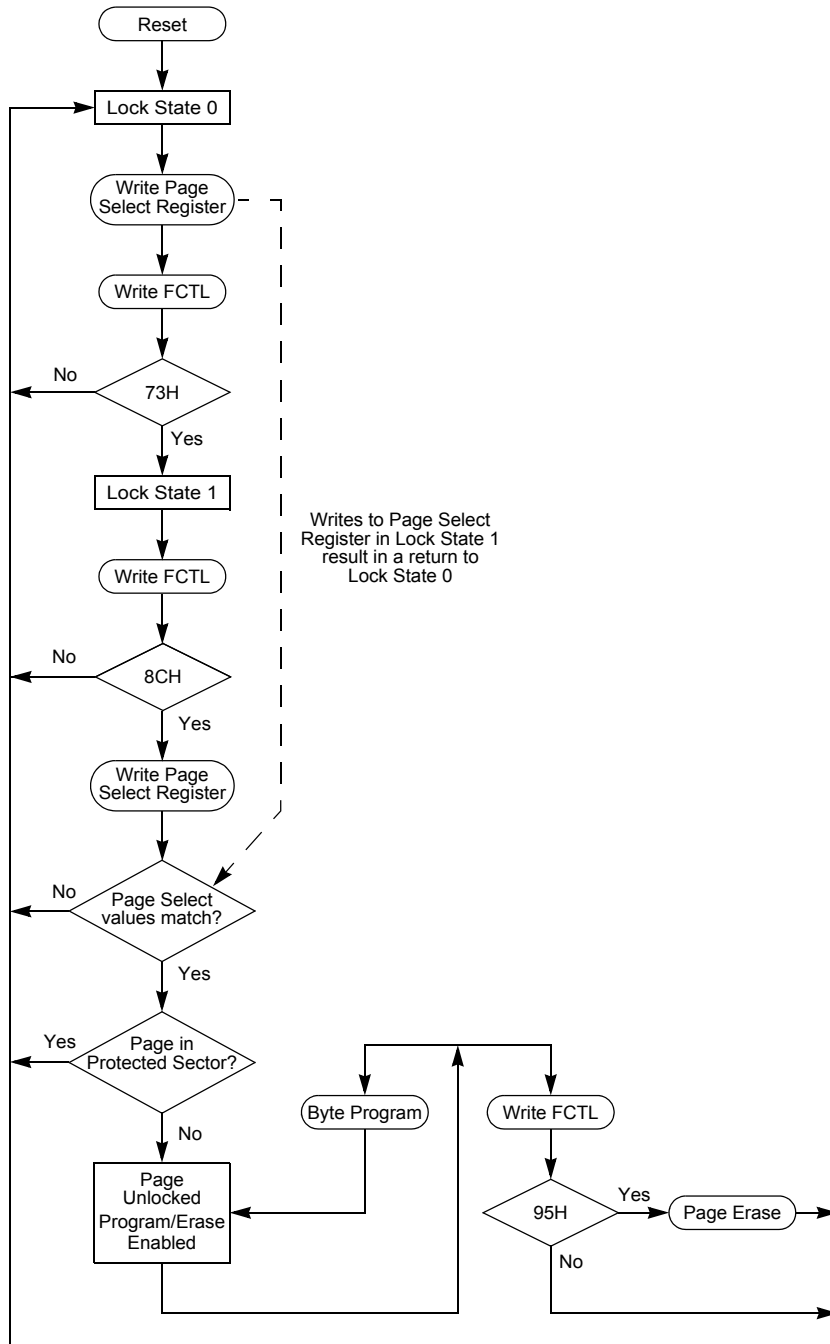

Figure 22. Flash Controller Operation Flow Chart

## Flash Operation Timing Using the Flash Frequency Registers

Before performing either a program or erase operation on Flash memory, you must first configure the Flash Frequency High and Low Byte registers. The Flash Frequency registers allow programming and erasing of the Flash with system clock frequencies ranging from 32 kHz (32768 Hz) through 20 MHz.

The Flash Frequency High and Low Byte registers combine to form a 16-bit value, FFREQ, to control timing for Flash program and erase operations. The 16-bit binary Flash Frequency value must contain the system clock frequency (in kHz). This value is calculated using the following equation:

$$\text{FFREQ}[15:0] = \frac{\text{System Clock Frequency (Hz)}}{1000}$$



**Caution:** *Flash programming and erasure are not supported for system clock frequencies below 32 kHz (32768 Hz) or above 20 MHz. The Flash Frequency High and Low Byte registers must be loaded with the correct value to ensure operation of the Z8 Encore! XP<sup>®</sup> F082A Series devices.*

## Flash Code Protection Against External Access

The user code contained within the Flash memory can be protected against external access by the on-chip debugger. Programming the FRP Flash Option Bit prevents reading of the user code with the On-Chip Debugger. See [Flash Option Bits](#) on page 153 and [On-Chip Debugger](#) on page 173 for more information.

## Flash Code Protection Against Accidental Program and Erasure

The Z8 Encore! XP F082A Series provides several levels of protection against accidental program and erasure of the Flash memory contents. This protection is provided by a combination of the Flash Option bits, the register locking mechanism, the page select redundancy and the sector level protection control of the Flash Controller.

### Flash Code Protection Using the Flash Option Bits

The FRP and FWP Flash Option Bits combine to provide three levels of Flash Program Memory protection as listed in [Table 77](#). See [Flash Option Bits](#) on page 153 for more information.

**Table 77. Flash Code Protection Using the Flash Option Bits**

<b>FWP</b>	<b>Flash Code Protection Description</b>
0	Programming and erasing disabled for all of Flash Program Memory. In user code programming, Page Erase, and Mass Erase are all disabled. Mass Erase is available through the On-Chip Debugger.
1	Programming, Page Erase, and Mass Erase are enabled for all of Flash Program Memory.

### Flash Code Protection Using the Flash Controller

At Reset, the Flash Controller locks to prevent accidental program or erasure of the Flash memory. To program or erase the Flash memory, first write the Page Select Register with the target page. Unlock the Flash Controller by making two consecutive writes to the Flash Control register with the values 73H and 8CH, sequentially. The Page Select Register must be rewritten with the target page. If the two Page Select writes do not match, the controller reverts to a locked state. If the two writes match, the selected page becomes active. See [Figure 22](#) on page 144 for details.

After unlocking a specific page, you can enable either Page Program or Erase. Writing the value 95H causes a Page Erase only if the active page resides in a sector that is not protected. Any other value written to the Flash Control register locks the Flash Controller. Mass Erase is not allowed in the user code but only in through the Debug Port.

After unlocking a specific page, you can also write to any byte on that page. After a byte is written, the page remains unlocked, allowing for subsequent writes to other bytes on the same page. Further writes to the Flash Control Register cause the active page to revert to a locked state.

### Sector Based Flash Protection

The final protection mechanism is implemented on a per-sector basis. The Flash memories of Z8 Encore!<sup>®</sup> devices are divided into at most 8 sectors. A sector is 1/8 of the total size of the Flash memory, unless this value is smaller than the page size, in which case the sector and page sizes are equal.

The Sector Protect register controls the protection state of each Flash sector. This register is shared with the Page Select Register. It is accessed by writing 73H followed by 5EH to the Flash controller. The next write to the Flash Control Register targets the Sector Protect Register.

The Sector Protect Register is initialized to 0 on reset, putting each sector into an unprotected state. When a bit in the Sector Protect Register is written to 1, the corresponding sector is no longer written or erased by the CPU. External Flash programming through

the OCD or via the Flash Controller Bypass mode are unaffected. After a bit of the Sector Protect Register has been set, it cannot be cleared except by powering down the device.

## Byte Programming

The Flash Memory is enabled for byte programming after unlocking the Flash Controller and successfully enabling either Mass Erase or Page Erase. When the Flash Controller is unlocked and Mass Erase is successfully completed, all Program Memory locations are available for byte programming. In contrast, when the Flash Controller is unlocked and Page Erase is successfully completed, only the locations of the selected page are available for byte programming. An erased Flash byte contains all 1's (FFH). The programming operation can only be used to change bits from 1 to 0. To change a Flash bit (or multiple bits) from 0 to 1 requires execution of either the Page Erase or Mass Erase commands.

Byte Programming can be accomplished using the On-Chip Debugger's Write Memory command or eZ8 CPU execution of the LDC or LDCI instructions. Refer to the *eZ8 CPU User Manual* (available for download at [www.zilog.com](http://www.zilog.com)) for a description of the LDC and LDCI instructions. While the Flash Controller programs the Flash memory, the eZ8 CPU idles but the system clock and on-chip peripherals continue to operate. To exit programming mode and lock the Flash, write any value to the Flash Control register, except the Mass Erase or Page Erase commands.



**Caution:** *The byte at each address of the Flash memory cannot be programmed (any bits written to 0) more than twice before an erase cycle occurs. Doing so may result in corrupted data at the target byte.*

## Page Erase

The Flash memory can be erased one page (512 bytes) at a time. Page Erasing the Flash memory sets all bytes in that page to the value FFH. The Flash Page Select register identifies the page to be erased. Only a page residing in an unprotected sector can be erased. With the Flash Controller unlocked and the active page set, writing the value 95h to the Flash Control register initiates the Page Erase operation. While the Flash Controller executes the Page Erase operation, the eZ8 CPU idles but the system clock and on-chip peripherals continue to operate. The eZ8 CPU resumes operation after the Page Erase operation completes. If the Page Erase operation is performed using the On-Chip Debugger, poll the Flash Status register to determine when the Page Erase operation is complete. When the Page Erase is complete, the Flash Controller returns to its locked state.

## Mass Erase

The Flash memory can also be Mass Erased using the Flash Controller, but only by using the On-Chip Debugger. Mass Erasing the Flash memory sets all bytes to the value FFH. With the Flash Controller unlocked and the Mass Erase successfully enabled, writing the

value 63H to the Flash Control register initiates the Mass Erase operation. While the Flash Controller executes the Mass Erase operation, the eZ8 CPU idles but the system clock and on-chip peripherals continue to operate. Using the On-Chip Debugger, poll the Flash Status register to determine when the Mass Erase operation is complete. When the Mass Erase is complete, the Flash Controller returns to its locked state.

## Flash Controller Bypass

The Flash Controller can be bypassed and the control signals for the Flash memory brought out to the GPIO pins. Bypassing the Flash Controller allows faster Row Programming algorithms by controlling the Flash programming signals directly.

Row programming is recommended for gang programming applications and large volume customers who do not require in-circuit initial programming of the Flash memory. Page Erase operations are also supported when the Flash Controller is bypassed.

For more information on bypassing the Flash Controller, refer to *Third-Party Flash Programming Support for Z8 Encore!<sup>®</sup> MCU Application Note (AN0117)* available for download at [www.zilog.com](http://www.zilog.com).

## Flash Controller Behavior in DEBUG Mode

The following changes in behavior of the Flash Controller occur when the Flash Controller is accessed using the On-Chip Debugger:

- The Flash Write Protect option bit is ignored.
- The Flash Sector Protect register is ignored for programming and erase operations.
- Programming operations are not limited to the page selected in the Page Select register.
- Bits in the Flash Sector Protect register can be written to one or zero.
- The second write of the Page Select register to unlock the Flash Controller is not necessary.
- The Page Select register can be written when the Flash Controller is unlocked.
- The Mass Erase command is enabled through the Flash Control register.



**Caution:** *For security reasons, the Flash controller allows only a single page to be opened for write/erase. When writing multiple Flash pages, the flash controller must go through the unlock sequence again to select another page.*

## Flash Control Register Definitions

### Flash Control Register

The Flash Controller must be unlocked using the Flash Control (FCTL) register before programming or erasing the Flash memory. Writing the sequence 73H 8CH, sequentially, to the Flash Control register unlocks the Flash Controller. When the Flash Controller is unlocked, the Flash memory can be enabled for Mass Erase or Page Erase by writing the appropriate enable command to the FCTL. Page Erase applies only to the active page selected in Flash Page Select register. Mass Erase is enabled only through the On-Chip Debugger. Writing an invalid value or an invalid sequence returns the Flash Controller to its locked state. The Write-only Flash Control Register shares its Register File address with the read-only Flash Status Register.

**Table 78. Flash Control Register (FCTL)**

BITS	7	6	5	4	3	2	1	0
FIELD	FCMD							
RESET	0	0	0	0	0	0	0	0
R/W	W	W	W	W	W	W	W	W
ADDR	FF8H							

FCMD—Flash Command

73H = First unlock command.

8CH = Second unlock command.

95H = Page Erase command (must be third command in sequence to initiate Page Erase).

63H = Mass Erase command (must be third command in sequence to initiate Mass Erase).

5EH = Enable Flash Sector Protect Register Access



## Flash Status Register

The Flash Status (FSTAT) register indicates the current state of the Flash Controller. This register can be read at any time. The read-only Flash Status register shares its Register File address with the Write-only Flash Control register.

**Table 79. Flash Status Register (FSTAT)**

BITS	7	6	5	4	3	2	1	0
FIELD	Reserved		FSTAT					
RESET	0	0	0	0	0	0	0	0
R/W	R	R	R	R	R	R	R	R
ADDR	FF8H							

Reserved—Must be 0.

FSTAT—Flash Controller Status

000000 = Flash Controller locked

000001 = First unlock command received (73H written)

000010 = Second unlock command received (8CH written)

000011 = Flash Controller unlocked

000100 = Sector protect register selected

001xxx = Program operation in progress

010xxx = Page erase operation in progress

100xxx = Mass erase operation in progress

## Flash Page Select Register

The Flash Page Select (FPS) register shares address space with the Flash Sector Protect Register. Unless the Flash controller is unlocked and written with 5EH, writes to this address target the Flash Page Select Register.

The register is used to select one of the available Flash memory pages to be programmed or erased. Each Flash Page contains 512 bytes of Flash memory. During a Page Erase operation, all Flash memory having addresses with the most significant 7 bits given by FPS[6:0] are chosen for program/erase operation.

**Table 80. Flash Page Select Register (FPS)**

BITS	7	6	5	4	3	2	1	0
FIELD	INFO_EN	PAGE						
RESET	0	0	0	0	0	0	0	0
R/W	R/W	R/W	R/W	R/W	R/W	R/W	R/W	R/W
ADDR	FF9H							

INFO\_EN—Information Area Enable

0 = Information Area us not selected.

1 = Information Area is selected. The Information Area is mapped into the Program Memory address space at addresses FE00H through FFFFH.

PAGE—Page Select

This 7-bit field identifies the Flash memory page for Page Erase and page unlocking. Program Memory Address[15:9] = PAGE[6:0]. For the Z8F08xx devices, the upper 3 bits must be zero. For the Z8F04xx devices, the upper 4 bits must be zero. For Z8F02xx devices, the upper 5 bits must always be 0. For the Z8F01xx devices, the upper 6 bits must always be 0.

## Flash Sector Protect Register

The Flash Sector Protect (FPROT) register is shared with the Flash Page Select Register. When the [Flash Control Register](#) is written with 73H followed by 5EH, the next write to this address targets the Flash Sector Protect Register. In all other cases, it targets the Flash Page Select Register.

This register selects one of the 8 available Flash memory sectors to be protected. The reset state of each Sector Protect bit is an unprotected state. After a sector is protected by setting its corresponding register bit, it cannot be unprotected (the register bit cannot be cleared) without powering down the device.

**Table 81. Flash Sector Protect Register (FPROT)**

BITS	7	6	5	4	3	2	1	0
FIELD	SPROT7	SPROT6	SPROT5	SPROT4	SPROT3	SPROT2	SPROT1	SPROT0
RESET	0	0	0	0	0	0	0	0
R/W	R/W	R/W	R/W	R/W	R/W	R/W	R/W	R/W
ADDR	FF9H							

SPROT7-SPROT0—Sector Protection

Each bit corresponds to a 512 byte Flash sector. For the Z8F08xx devices, the upper 3 bits must be zero. For the Z8F04xx devices all bits are used. For the Z8F02xx devices, the upper 4 bits are unused. For the Z8F01xx devices, the upper 6 bits are unused.

### Flash Frequency High and Low Byte Registers

The Flash Frequency High (FFREQH) and Low Byte (FFREQL) registers combine to form a 16-bit value, FFREQ, to control timing for Flash program and erase operations. The 16-bit binary Flash Frequency value must contain the system clock frequency (in kHz) and is calculated using the following equation:

$$FFREQ[15:0] = \{FFREQH[7:0], FFREQL[7:0]\} = \frac{\text{System Clock Frequency}}{1000}$$



**Caution:** *The Flash Frequency High and Low Byte registers must be loaded with the correct value to ensure proper operation of the device. Also, Flash programming and erasure is not supported for system clock frequencies below 20 kHz or above 20 MHz.*

**Table 82. Flash Frequency High Byte Register (FFREQH)**

BITS	7	6	5	4	3	2	1	0
FIELD	FFREQH							
RESET	0	0	0	0	0	0	0	0
R/W	R/W	R/W	R/W	R/W	R/W	R/W	R/W	R/W
ADDR	FFAH							

FFREQH—Flash Frequency High Byte  
High byte of the 16-bit Flash Frequency value.

**Table 83. Flash Frequency Low Byte Register (FFREQL)**

BITS	7	6	5	4	3	2	1	0
FIELD	FFREQL							
RESET	0							
R/W	R/W							
ADDR	FFBH							

FFREQL—Flash Frequency Low Byte  
Low byte of the 16-bit Flash Frequency value.

# Flash Option Bits

Programmable Flash option bits allow user configuration of certain aspects of Z8 Encore! XP<sup>®</sup> F082A Series operation. The feature configuration data is stored in the Flash program memory and loaded into holding registers during Reset. The features available for control through the Flash Option Bits include:

- Watchdog Timer time-out response selection—interrupt or system reset
- Watchdog Timer always on (enabled at Reset)
- The ability to prevent unwanted read access to user code in Program Memory
- The ability to prevent accidental programming and erasure of all or a portion of the user code in Program Memory
- Voltage Brownout configuration—always enabled or disabled during STOP mode to reduce STOP mode power consumption
- Oscillator mode selection—for high, medium, and low power crystal oscillators, or external RC oscillator
- Factory trimming information for the internal precision oscillator and low voltage detection
- Factory calibration values for ADC, temperature sensor, and Watchdog Timer compensation
- Factory serialization and randomized lot identifier (optional)

## Operation

### Option Bit Configuration By Reset

Each time the Flash Option Bits are programmed or erased, the device must be Reset for the change to take effect. During any reset operation (System Reset, Power-On Reset, or Stop Mode Recovery), the Flash Option Bits are automatically read from the Flash Program Memory and written to Option Configuration registers. The Option Configuration registers control operation of the devices within the Z8 Encore! XP F082A Series. Option Bit control is established before the device exits Reset and the eZ8 CPU begins code execution. The Option Configuration registers are not part of the Register File and are not accessible for read or write access.

## Option Bit Types

### User Option Bits

The user option bits are contained in the first two bytes of program memory. User access to these bits has been provided because these locations contain application-specific device configurations. The information contained here is lost when page 0 of the program memory is erased.

### Trim Option Bits

The trim option bits are contained in the information page of the Flash memory. These bits are factory programmed values required to optimize the operation of onboard analog circuitry and cannot be permanently altered. Program Memory may be erased without endangering these values. It is possible to alter working values of these bits by accessing the Trim Bit Address and Data Registers, but these working values are lost after a power loss or any other reset event.

There are 32 bytes of trim data. To modify one of these values the user code must first write a value between 00H and 1FH into the Trim Bit Address Register. The next write to the Trim Bit Data register changes the working value of the target trim data byte.

Reading the trim data requires the user code to write a value between 00H and 1FH into the Trim Bit Address Register. The next read from the Trim Bit Data register returns the working value of the target trim data byte.

► **Note:** *The trim address range is from information address 20-3F only. The remainder of the information page is not accessible through the trim bit address and data registers.*

### Calibration Option Bits

The calibration option bits are also contained in the information page. These bits are factory programmed values intended for use in software correcting the device's analog performance. To read these values, the user code must employ the LDC instruction to access the information area of the address space as defined in [See Flash Information Area](#) on page 17.

### Serialization Bits

As an optional feature, Zilog<sup>®</sup> is able to provide factory-programmed serialization. For serialized products, the individual devices are programmed with unique serial numbers. These serial numbers are binary values, four bytes in length. The numbers increase in size with each device, but gaps in the serial sequence may exist.

These serial numbers are stored in the Flash information page (see [Reading the Flash Information Page](#) on page 155 and [Serialization Data](#) on page 165 for more details) and are unaffected by mass erasure of the device's Flash memory.

### Randomized Lot Identification Bits

As an optional feature, Zilog is able to provide a factory-programmed random lot identifier. With this feature, all devices in a given production lot are programmed with the same random number. This random number is uniquely regenerated for each successive production lot and is not likely to be repeated.

The randomized lot identifier is a 32 byte binary value, stored in the Flash information page (see [Reading the Flash Information Page](#) on page 155 and [Randomized Lot Identifier](#) on page 166 for more details) and is unaffected by mass erasure of the device's Flash memory.

### Reading the Flash Information Page

The following code example shows how to read data from the Flash information area.

```
; get value at info address 60 (FE60h)
ldx FPS, #%80 ; enable access to flash info page
ld R0, #%FE
ld R1, #%60
ldc R2, @RR0 ; R2 now contains the calibration value
```

## Flash Option Bit Control Register Definitions

### Trim Bit Address Register

The Trim Bit Address (TRMADR) register contains the target address for an access to the trim option bits ([Table 84](#)).

**Table 84. Trim Bit Address Register (TRMADR)**

BITS	7	6	5	4	3	2	1	0
FIELD	TRMADR - Trim Bit Address (00H to 1FH)							
RESET	0	0	0	0	0	0	0	0
R/W	R/W	R/W	R/W	R/W	R/W	R/W	R/W	R/W
ADDR	FF6H							

## Trim Bit Data Register

The Trim Bid Data (TRMDR) register contains the read or write data for access to the trim option bits (Table 85).

**Table 85. Trim Bit Data Register (TRMDR)**

BITS	7	6	5	4	3	2	1	0
FIELD	TRMDR - Trim Bit Data							
RESET	0	0	0	0	0	0	0	0
R/W	R/W	R/W	R/W	R/W	R/W	R/W	R/W	R/W
ADDR	FF7H							

## Flash Option Bit Address Space

The first two bytes of Flash program memory at addresses 0000H and 0001H are reserved for the user-programmable Flash option bits.

### Flash Program Memory Address 0000H

**Table 86. Flash Option Bits at Program Memory Address 0000H**

BITS	7	6	5	4	3	2	1	0
FIELD	WDT_RES	WDT_AO	OSC_SEL[1:0]		VBO_AO	FRP	Reserved	FWP
RESET	U	U	U	U	U	U	U	U
R/W	R/W	R/W	R/W	R/W	R/W	R/W	R/W	R/W
ADDR	Program Memory 0000H							
<b>Note:</b> U = Unchanged by Reset. R/W = Read/Write.								

**WDT\_RES**—Watchdog Timer Reset

0 = Watchdog Timer time-out generates an interrupt request. Interrupts must be globally enabled for the eZ8 CPU to acknowledge the interrupt request.

1 = Watchdog Timer time-out causes a system reset. This setting is the default for unprogrammed (erased) Flash.

**WDT\_AO**—Watchdog Timer Always On

0 = Watchdog Timer is automatically enabled upon application of system power. Watchdog Timer can not be disabled.

1 = Watchdog Timer is enabled upon execution of the WDT instruction. Once enabled, the Watchdog Timer can only be disabled by a Reset or Stop Mode Recovery. This setting is the default for unprogrammed (erased) Flash.

OSC\_SEL[1:0]—Oscillator Mode Selection

00 = On-chip oscillator configured for use with external RC networks (<4 MHz).

01 = Minimum power for use with very low frequency crystals (32 kHz to 1.0 MHz).

10 = Medium power for use with medium frequency crystals or ceramic resonators (0.5 MHz to 5.0 MHz).

11 = Maximum power for use with high frequency crystals (5.0 MHz to 20.0 MHz). This setting is the default for unprogrammed (erased) Flash.

VBO\_AO—Voltage Brownout Protection Always On

0 = Voltage Brownout Protection can be disabled in STOP mode to reduce total power consumption. For the block to be disabled, the power control register bit must also be written (see [Power Control Register Definitions](#) on page 34).

1 = Voltage Brownout Protection is always enabled including during STOP mode. This setting is the default for unprogrammed (erased) Flash.

FRP—Flash Read Protect

0 = User program code is inaccessible. Limited control features are available through the On-Chip Debugger.

1 = User program code is accessible. All On-Chip Debugger commands are enabled. This setting is the default for unprogrammed (erased) Flash.

Reserved—Must be 1.

FWP—Flash Write Protect

This Option Bit provides Flash Program Memory protection:

0 = Programming and erasure disabled for all of Flash Program Memory. Programming, Page Erase, and Mass Erase through User Code is disabled. Mass Erase is available using the On-Chip Debugger.

1 = Programming, Page Erase, and Mass Erase are enabled for all of Flash program memory.



## Flash Program Memory Address 0001H

Table 87. Flash Options Bits at Program Memory Address 0001H

BITS	7	6	5	4	3	2	1	0
FIELD	Reserved			XTLDIS	Reserved			
RESET	U	U	U	U	U	U	U	U
R/W	R/W	R/W	R/W	R/W	R/W	R/W	R/W	R/W
ADDR	Program Memory 0001H							

**Note:** U = Unchanged by Reset. R/W = Read/Write.

Reserved—Must be 1.

XTLDIS—State of Crystal Oscillator at Reset.

► **Note:** *This bit only enables the crystal oscillator. Its selection as system clock must be done manually.*

*0 = Crystal oscillator is enabled during reset, resulting in longer reset timing*

*1 = Crystal oscillator is disabled during reset, resulting in shorter reset timing*



**Warning:** *Programming the XTLDIS bit to zero on 8-pin versions of this device prevents any further communication via the debug pin. This is due to the fact that the XIN and DBG functions are shared on pin 2 of this package. Do not program this bit to zero on 8-pin devices unless no further debugging or Flash programming is required.*

## Trim Bit Address Space

All available Trim bit addresses and their functions are listed in [Table 88](#) through [Table 92](#).

### Trim Bit Address 0000H

Table 88. Trim Options Bits at Address 0000H

BITS	7	6	5	4	3	2	1	0
FIELD	Reserved							
RESET	U	U	U	U	U	U	U	U
R/W	R/W	R/W	R/W	R/W	R/W	R/W	R/W	R/W
ADDR	Information Page Memory 0020H							

**Note:** U = Unchanged by Reset. R/W = Read/Write.

Reserved—Altering this register may result in incorrect device operation.

### Trim Bit Address 0001H

Table 89. Trim Option Bits at 0001H

BITS	7	6	5	4	3	2	1	0
FIELD	Reserved							
RESET	U	U	U	U	U	U	U	U
R/W	R/W	R/W	R/W	R/W	R/W	R/W	R/W	R/W
ADDR	Information Page Memory 0021H							
<b>Note:</b> U = Unchanged by Reset. R/W = Read/Write.								

Reserved—Altering this register may result in incorrect device operation.

### Trim Bit Address 0002H

Table 90. Trim Option Bits at 0002H (TIPO)

BITS	7	6	5	4	3	2	1	0
FIELD	IPO_TRIM							
RESET	U							
R/W	R/W							
ADDR	Information Page Memory 0022H							
<b>Note:</b> U = Unchanged by Reset. R/W = Read/Write.								

IPO\_TRIM—Internal Precision Oscillator Trim Byte  
Contains trimming bits for Internal Precision Oscillator.

### Trim Bit Address 0003H

► **Note:** *The LVD is available on 8-pin devices only.*

Table 91. Trim Option Bits at Address 0003H (TLVD)

BITS	7	6	5	4	3	2	1	0
FIELD	Reserved			LVD_TRIM				
RESET	U	U	U	U	U	U	U	U
R/W	R/W	R/W	R/W	R/W	R/W	R/W	R/W	R/W
ADDR	Information Page Memory 0023H							
<b>Note:</b> U = Unchanged by Reset. R/W = Read/Write.								

Reserved—Must be 1.

LVD\_TRIM—Low Voltage Detect Trim

This trimming affects the low voltage detection threshold. Each LSB represents a 50 mV change in the threshold level. Alternatively, the low voltage threshold may be computed from the options bit value by the following equation:

$$\text{LVD\_LVL} = 3.6 \text{ V} - \text{LVD\_TRIM} \times 0.05 \text{ V}$$

LVD Threshold (V)		
LVD_TRIM	Typical	Description
00000	3.60	Maximum LVD threshold
00001	3.55	
00010	3.50	
00011	3.45	
00100	3.40	
00101	3.35	
00110	3.30	
00111	3.25	
01000	3.20	
01001	3.15	
01010	3.10	Default on Reset
01011	3.05	
01100	3.00	
01101	2.95	
01110	2.90	
01111	2.85	
10000	2.80	
10001	2.75	
10010	2.70	
10011	2.70	
to	to	
11111	1.65	Minimum LVD threshold

## Trim Bit Address 0004H

Table 92. Trim Option Bits at 0004H

BITS	7	6	5	4	3	2	1	0
FIELD	Reserved							
RESET	U	U	U	U	U	U	U	U
R/W	R/W	R/W	R/W	R/W	R/W	R/W	R/W	R/W
ADDR	Information Page Memory 0024H							

Note: U = Unchanged by Reset. R/W = Read/Write.

Reserved—Altering this register may result in incorrect device operation.

## Zilog Calibration Data

### ADC Calibration Data

Table 93. ADC Calibration Bits

BITS	7	6	5	4	3	2	1	0
FIELD	ADC_CAL							
RESET	U	U	U	U	U	U	U	U
R/W	R/W	R/W	R/W	R/W	R/W	R/W	R/W	R/W
ADDR	Information Page Memory 0060H–007DH							

Note: U = Unchanged by Reset. R/W = Read/Write.

ADC\_CAL—Analog-to-Digital Converter Calibration Values

Contains factory calibrated values for ADC gain and offset compensation. Each of the ten supported modes has one byte of offset calibration and two bytes of gain calibration.

These values are read by the software to compensate ADC measurements as described in [Software Compensation Procedure Using Factory Calibration Data](#) on page 126. The location of each calibration byte is provided in [Table 94](#) on page 162.

**Table 94. ADC Calibration Data Location**

<b>Info Page Address</b>	<b>Memory Address</b>	<b>Compensation Usage</b>	<b>ADC Mode</b>	<b>Reference Type</b>
60	FE60	Offset	Single-Ended Unbuffered	Internal 2.0 V
08	FE08	Gain High Byte	Single-Ended Unbuffered	Internal 2.0 V
09	FE09	Gain Low Byte	Single-Ended Unbuffered	Internal 2.0 V
63	FE63	Offset	Single-Ended Unbuffered	Internal 1.0 V
0A	FE0A	Gain High Byte	Single-Ended Unbuffered	Internal 1.0 V
0B	FE0B	Gain Low Byte	Single-Ended Unbuffered	Internal 1.0 V
66	FE66	Offset	Single-Ended Unbuffered	External 2.0 V
0C	FE0C	Gain High Byte	Single-Ended Unbuffered	External 2.0 V
0D	FE0D	Gain Low Byte	Single-Ended Unbuffered	External 2.0 V
69	FE69	Offset	Single-Ended 1x Buffered	Internal 2.0 V
0E	FE0E	Gain High Byte	Single-Ended 1x Buffered	Internal 2.0 V
0F	FE0F	Gain Low Byte	Single-Ended 1x Buffered	Internal 2.0 V
6C	FE6C	Offset	Single-Ended 1x Buffered	External 2.0 V
10	FE10	Gain High Byte	Single-Ended 1x Buffered	External 2.0 V
11	FE11	Gain Low Byte	Single-Ended 1x Buffered	External 2.0 V
6F	FE6F	Offset	Differential Unbuffered	Internal 2.0 V
12	FE12	Positive Gain High Byte	Differential Unbuffered	Internal 2.0 V
13	FE13	Positive Gain Low Byte	Differential Unbuffered	Internal 2.0 V
30	FE30	Negative Gain High Byte	Differential Unbuffered	Internal 2.0 V
31	FE31	Negative Gain Low Byte	Differential Unbuffered	Internal 2.0 V
72	FE72	Offset	Differential Unbuffered	Internal 1.0 V
14	FE14	Positive Gain High Byte	Differential Unbuffered	Internal 1.0 V
15	FE15	Positive Gain Low Byte	Differential Unbuffered	Internal 1.0 V
32	FE32	Negative Gain High Byte	Differential Unbuffered	Internal 1.0 V
33	FE33	Negative Gain Low Byte	Differential Unbuffered	Internal 1.0 V
75	FE75	Offset	Differential Unbuffered	External 2.0 V
16	FE16	Positive Gain High Byte	Differential Unbuffered	External 2.0 V
17	FE17	Positive Gain Low Byte	Differential Unbuffered	External 2.0 V

**Table 94. ADC Calibration Data Location (Continued)**

<b>Info Page Address</b>	<b>Memory Address</b>	<b>Compensation Usage</b>	<b>ADC Mode</b>	<b>Reference Type</b>
34	FE34	Negative Gain High Byte	Differential Unbuffered	External 2.0 V
35	FE35	Negative Gain Low Byte	Differential Unbuffered	External 2.0 V
78	FE78	Offset	Differential 1x Buffered	Internal 2.0 V
18	FE18	Positive Gain High Byte	Differential 1x Buffered	Internal 2.0 V
19	FE19	Positive Gain Low Byte	Differential 1x Buffered	Internal 2.0 V
36	FE36	Negative Gain High Byte	Differential 1x Buffered	Internal 2.0 V
37	FE37	Negative Gain Low Byte	Differential 1x Buffered	Internal 2.0 V
7B	FE7B	Offset	Differential 1x Buffered	External 2.0 V
1A	FE1A	Positive Gain High Byte	Differential 1x Buffered	External 2.0 V
1B	FE1B	Positive Gain Low Byte	Differential 1x Buffered	External 2.0 V
38	FE38	Negative Gain High Byte	Differential 1x Buffered	External 2.0 V
39	FE39	Negative Gain Low Byte	Differential 1x Buffered	External 2.0 V

## Temperature Sensor Calibration Data

**Table 95. Temperature Sensor Calibration High Byte at 003A (TSCALH)**

BITS	7	6	5	4	3	2	1	0
FIELD	TSCALH							
RESET	U	U	U	U	U	U	U	U
R/W	R/W	R/W	R/W	R/W	R/W	R/W	R/W	R/W
ADDR	Information Page Memory 003A							
<b>Note:</b> U = Unchanged by Reset. R/W = Read/Write.								

TSCALH – Temperature Sensor Calibration High Byte

The TSCALH and TSCALL bytes combine to form the 12-bit temperature sensor offset calibration value. For more details, see [Temperature Sensor Operation](#) on page 139.

**Table 96. Temperature Sensor Calibration Low Byte at 003B (TSCALL)**

BITS	7	6	5	4	3	2	1	0
FIELD	TSCALL							
RESET	U	U	U	U	U	U	U	U
R/W	R/W	R/W	R/W	R/W	R/W	R/W	R/W	R/W
ADDR	Information Page Memory 003B							
<b>Note:</b> U = Unchanged by Reset. R/W = Read/Write.								

TSCALL – Temperature Sensor Calibration Low Byte

The TSCALH and TSCALL bytes combine to form the 12-bit temperature sensor offset calibration value. For usage details, see [Temperature Sensor Operation](#) on page 139.

## Watchdog Timer Calibration Data

**Table 97. Watchdog Calibration High Byte at 007EH (WDTCALH)**

BITS	7	6	5	4	3	2	1	0
FIELD	WDTCALH							
RESET	U	U	U	U	U	U	U	U
R/W	R/W	R/W	R/W	R/W	R/W	R/W	R/W	R/W
ADDR	Information Page Memory 007EH							
<b>Note:</b> U = Unchanged by Reset. R/W = Read/Write.								

**WDTCALH—Watchdog Timer Calibration High Byte**

The WDTCALH and WDTCALL bytes, when loaded into the Watchdog Timer reload registers result in a one second timeout at room temperature and 3.3 V supply voltage. To use the Watchdog Timer calibration, user code must load WDTU with 0x00, WDTL with WDTCALH and WDTL with WDTCALL.

**Table 98. Watchdog Calibration Low Byte at 007FH (WDTCALL)**

<b>BITS</b>	<b>7</b>	<b>6</b>	<b>5</b>	<b>4</b>	<b>3</b>	<b>2</b>	<b>1</b>	<b>0</b>
<b>FIELD</b>	WDTCALL							
<b>RESET</b>	U	U	U	U	U	U	U	U
<b>R/W</b>	R/W	R/W	R/W	R/W	R/W	R/W	R/W	R/W
<b>ADDR</b>	Information Page Memory 007FH							
<b>Note:</b> U = Unchanged by Reset. R/W = Read/Write.								

**WDTCALL—Watchdog Timer Calibration Low Byte**

The WDTCALH and WDTCALL bytes, when loaded into the Watchdog Timer reload registers result in a one second timeout at room temperature and 3.3 V supply voltage. To use the Watchdog Timer calibration, user code must load WDTU with 0x00, WDTL with WDTCALH and WDTL with WDTCALL.

**Serialization Data**

**Table 99. Serial Number at 001C - 001F (S\_NUM)**

<b>BITS</b>	<b>7</b>	<b>6</b>	<b>5</b>	<b>4</b>	<b>3</b>	<b>2</b>	<b>1</b>	<b>0</b>
<b>FIELD</b>	S_NUM							
<b>RESET</b>	U	U	U	U	U	U	U	U
<b>R/W</b>	R/W	R/W	R/W	R/W	R/W	R/W	R/W	R/W
<b>ADDR</b>	Information Page Memory 001C-001F							
<b>Note:</b> U = Unchanged by Reset. R/W = Read/Write.								

**S\_NUM—Serial Number Byte**

The serial number is a unique four-byte binary value.



**Table 100. Serialization Data Locations**

Info Page Address	Memory Address	Usage
1C	FE1C	Serial Number Byte 3 (most significant)
1D	FE1D	Serial Number Byte 2
1E	FE1E	Serial Number Byte 1
1F	FE1F	Serial Number Byte 0 (least significant)

### Randomized Lot Identifier

**Table 101. Lot Identification Number (RAND\_LOT)**

BITS	7	6	5	4	3	2	1	0
FIELD	RAND_LOT							
RESET	U	U	U	U	U	U	U	U
R/W	R/W	R/W	R/W	R/W	R/W	R/W	R/W	R/W
ADDR	Interspersed throughout Information Page Memory							
<b>Note:</b> U = Unchanged by Reset. R/W = Read/Write.								

RAND\_LOT—Randomized Lot ID

The randomized lot ID is a 32 byte binary value that changes for each production lot.

**Table 102. Randomized Lot ID Locations**

Info Page Address	Memory Address	Usage
3C	FE3C	Randomized Lot ID Byte 31 (most significant)
3D	FE3D	Randomized Lot ID Byte 30
3E	FE3E	Randomized Lot ID Byte 29
3F	FE3F	Randomized Lot ID Byte 28
58	FE58	Randomized Lot ID Byte 27
59	FE59	Randomized Lot ID Byte 26
5A	FE5A	Randomized Lot ID Byte 25
5B	FE5B	Randomized Lot ID Byte 24

**Table 102. Randomized Lot ID Locations (Continued)**

<b>Info Page Address</b>	<b>Memory Address</b>	<b>Usage</b>
5C	FE5C	Randomized Lot ID Byte 23
5D	FE5D	Randomized Lot ID Byte 22
5E	FE5E	Randomized Lot ID Byte 21
5F	FE5F	Randomized Lot ID Byte 20
61	FE61	Randomized Lot ID Byte 19
62	FE62	Randomized Lot ID Byte 18
64	FE64	Randomized Lot ID Byte 17
65	FE65	Randomized Lot ID Byte 16
67	FE67	Randomized Lot ID Byte 15
68	FE68	Randomized Lot ID Byte 14
6A	FE6A	Randomized Lot ID Byte 13
6B	FE6B	Randomized Lot ID Byte 12
6D	FE6D	Randomized Lot ID Byte 11
6E	FE6E	Randomized Lot ID Byte 10
70	FE70	Randomized Lot ID Byte 9
71	FE71	Randomized Lot ID Byte 8
73	FE73	Randomized Lot ID Byte 7
74	FE74	Randomized Lot ID Byte 6
76	FE76	Randomized Lot ID Byte 5
77	FE77	Randomized Lot ID Byte 4
79	FE79	Randomized Lot ID Byte 3
7A	FE7A	Randomized Lot ID Byte 2
7C	FE7C	Randomized Lot ID Byte 1
7D	FE7D	Randomized Lot ID Byte 0 (least significant)



# Non-Volatile Data Storage

The Z8 Encore! XP<sup>®</sup> F082A Series devices contain a non-volatile data storage (NVDS) element of up to 128 bytes. This memory can perform over 100,000 write cycles.

## Operation

The NVDS is implemented by special purpose Zilog<sup>®</sup> software stored in areas of program memory, which are not user-accessible. These special-purpose routines use the Flash memory to store the data. The routines incorporate a dynamic addressing scheme to maximize the write/erase endurance of the Flash.

- **Note:** *Different members of the Z8 Encore! XP F082A Series feature multiple NVDS array sizes. See [Z8 Encore! XP<sup>®</sup> F082A Series Family Part Selection Guide](#) on page 3 for details. Also the members containing 8 KB of Flash memory do not include the NVDS feature.*

## NVDS Code Interface

Two routines are required to access the NVDS: a write routine and a read routine. Both of these routines are accessed with a CALL instruction to a pre-defined address outside of the user-accessible program memory. Both the NVDS address and data are single-byte values. Because these routines disturb the working register set, user code must ensure that any required working register values are preserved by pushing them onto the stack or by changing the working register pointer just prior to NVDS execution.

During both read and write accesses to the NVDS, interrupt service is NOT disabled. Any interrupts that occur during the NVDS execution must take care not to disturb the working register and existing stack contents or else the array may become corrupted. Disabling interrupts before executing NVDS operations is recommended.

Use of the NVDS requires 15 bytes of available stack space. Also, the contents of the working register set are overwritten.

For correct NVDS operation, the Flash Frequency Registers must be programmed based on the system clock frequency (see [Flash Operation Timing Using the Flash Frequency Registers](#) on page 145).

## Byte Write

To write a byte to the NVDS array, the user code must first push the address, then the data byte onto the stack. The user code issues a CALL instruction to the address of the byte-write routine (0x10B3). At the return from the sub-routine, the write status byte

resides in working register R0. The bit fields of this status byte are defined in [Table 103](#). The contents of the status byte are undefined for write operations to illegal addresses. Also, user code must pop the address and data bytes off the stack.

The write routine uses 13 bytes of stack space in addition to the two bytes of address and data pushed by the user. Sufficient memory must be available for this stack usage.

Because of the Flash memory architecture, NVDS writes exhibit a non-uniform execution time. In general, a write takes 251  $\mu$ s (assuming a 20 MHz system clock). Every 400 to 500 writes, however, a maintenance operation is necessary. In this rare occurrence, the write takes up to 61 ms to complete. Slower system clock speeds result in proportionally higher execution times.

NVDS byte writes to invalid addresses (those exceeding the NVDS array size) have no effect. Illegal write operations have a 2  $\mu$ s execution time.

**Table 103. Write Status Byte**

<b>BITS</b>	<b>7</b>	<b>6</b>	<b>5</b>	<b>4</b>	<b>3</b>	<b>2</b>	<b>1</b>	<b>0</b>
<b>FIELD</b>	Reserved				RCPY	PF	AWE	DWE
<b>DEFAULT VALUE</b>	0	0	0	0	0	0	0	0

Reserved—Must be 0.

RCPY—Recopy Subroutine Executed

A recopy subroutine was executed. These operations take significantly longer than a normal write operation.

PF—Power Failure Indicator

A power failure or system reset occurred during the most recent attempted write to the NVDS array.

AW—Address Write Error

An address byte failure occurred during the most recent attempted write to the NVDS array.

DWE—Data Write Error

A data byte failure occurred during the most recent attempted write to the NVDS array.

## Byte Read

To read a byte from the NVDS array, user code must first push the address onto the stack. User code issues a CALL instruction to the address of the byte-read routine (0x1000). At the return from the sub-routine, the read byte resides in working register R0, and the read status byte resides in working register R1. The contents of the status byte are undefined for

read operations to illegal addresses. Also, the user code must pop the address byte off the stack.

The read routine uses 9 bytes of stack space in addition to the one byte of address pushed by the user. Sufficient memory must be available for this stack usage.

Because of the Flash memory architecture, NVDS reads exhibit a non-uniform execution time. A read operation takes between 44  $\mu$ s and 489  $\mu$ s (assuming a 20 MHz system clock). Slower system clock speeds result in proportionally higher execution times.

NVDS byte reads from invalid addresses (those exceeding the NVDS array size) return 0xff. Illegal read operations have a 2  $\mu$ s execution time.

The status byte returned by the NVDS read routine is zero for successful read, as determined by a CRC check. If the status byte is non-zero, there was a corrupted value in the NVDS array at the location being read. In this case, the value returned in R0 is the byte most recently written to the array that does not have a CRC error.

## Power Failure Protection

The NVDS routines employ error checking mechanisms to ensure a power failure endangers only the most recently written byte. Bytes previously written to the array are not perturbed.

A system reset (such as a pin reset or Watchdog Timer reset) that occurs during a write operation also perturbs the byte currently being written. All other bytes in the array are unperturbed.

## Optimizing NVDS Memory Usage for Execution Speed

The NVDS read time varies drastically, this discrepancy being a trade-off for minimizing the frequency of writes that require post-write page erases (see [Table 104](#)). The NVDS read time of address N is a function of the number of writes to addresses other than N since the most recent write to address N, as well as the number of writes since the most recent page erase. Neglecting effects caused by page erases and results caused by the initial condition in which the NVDS is blank, a rule of thumb is that every write since the most recent page erase causes read times of unwritten addresses to increase by 1  $\mu$ s, up to a maximum of (511-NVDS\_SIZE)  $\mu$ s.

**Table 104. NVDS Read Time**

Operation	Minimum Latency	Maximum Latency
Read (16 byte array)	875	9961
Read (64 byte array)	876	8952

**Table 104. NVDS Read Time (Continued)**

<b>Operation</b>	<b>Minimum Latency</b>	<b>Maximum Latency</b>
Read (128 byte array)	883	7609
Write (16 byte array)	4973	5009
Write (64 byte array)	4971	5013
Write (128 byte array)	4984	5023
Illegal Read	43	43
Illegal Write	31	31

If NVDS read performance is critical to your software architecture, there are some things you can do to optimize your code for speed, listed in order from most helpful to least helpful:

- Periodically refresh all addresses that are used. The optimal use of NVDS in terms of speed is to rotate the writes evenly among all addresses planned to use, bringing all reads closer to the minimum read time. Because the minimum read time is much less than the write time, however, actual speed benefits are not always realized.
- Use as few unique addresses as possible: this helps to optimize the impact of refreshing as well as minimize the requirement for it.

# On-Chip Debugger

The Z8 Encore! XP<sup>®</sup> F082A Series devices contain an integrated On-Chip Debugger (OCD) that provides advanced debugging features including:

- Single pin interface.
- Reading and writing of the register file.
- Reading and writing of program and data memory.
- Setting of breakpoints and watchpoints.
- Executing eZ8 CPU instructions.
- Debug pin sharing with general-purpose input-output function to maximize pins available to the user (8-pin product only).

## Architecture

The on-chip debugger consists of four primary functional blocks: transmitter, receiver, auto-baud detector/generator, and debug controller. [Figure 23](#) displays the architecture of the on-chip debugger.

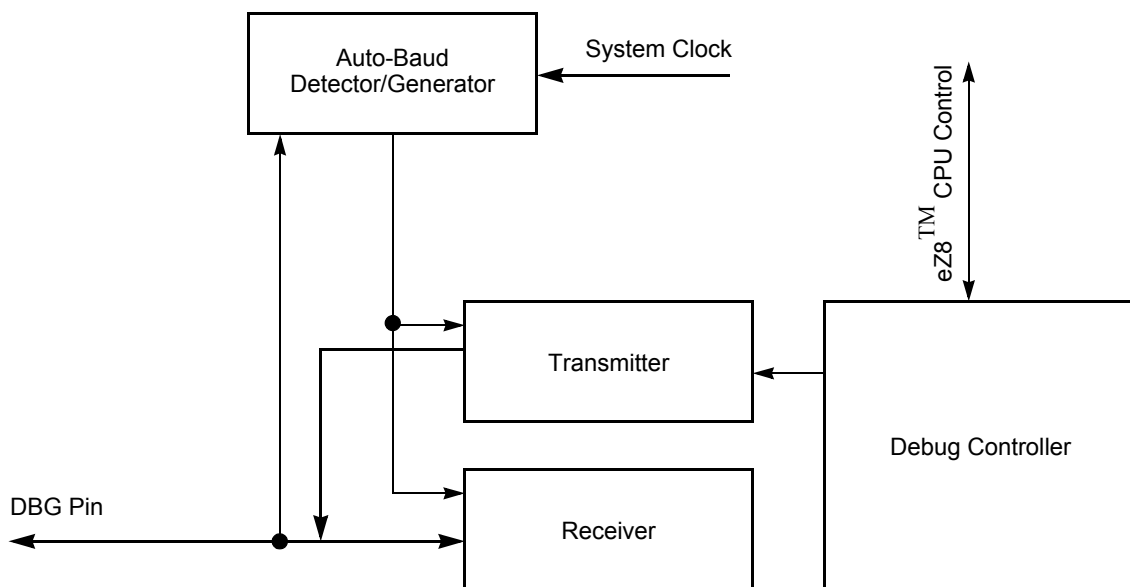

**Figure 23. On-Chip Debugger Block Diagram**



## Operation

### OCD Interface

The on-chip debugger uses the DBG pin for communication with an external host. This one-pin interface is a bi-directional, open-drain interface that transmits and receives data. Data transmission is half-duplex, in that transmit and receive cannot occur simultaneously. The serial data on the DBG pin is sent using the standard asynchronous data format defined in RS-232. This pin creates an interface from the Z8 Encore! XP<sup>®</sup> F082A Series products to the serial port of a host PC using minimal external hardware. Two different methods for connecting the DBG pin to an RS-232 interface are displayed in [Figure 24](#) and [Figure 25](#). The recommended method is the buffered implementation displayed in [Figure 25](#). The DBG pin has a internal pull-up resistor which is sufficient for some applications (for more details on the pull-up current, see [Electrical Characteristics](#) on page 221). For OCD operation at higher data rates or in noisy systems, an external pull-up resistor is recommended.



**Caution:**

*For operation of the on-chip debugger, all power pins ( $V_{DD}$  and  $AV_{DD}$ ) must be supplied with power, and all ground pins ( $V_{SS}$  and  $AV_{SS}$ ) must be properly grounded. The DBG pin is open-drain and may require an external pull-up resistor to ensure proper operation.*

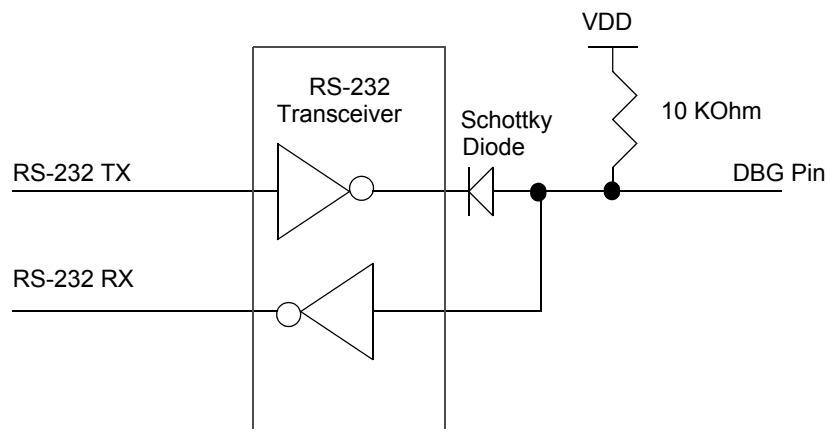

**Figure 24. Interfacing the On-Chip Debugger's DBG Pin with an RS-232 Interface (1)**

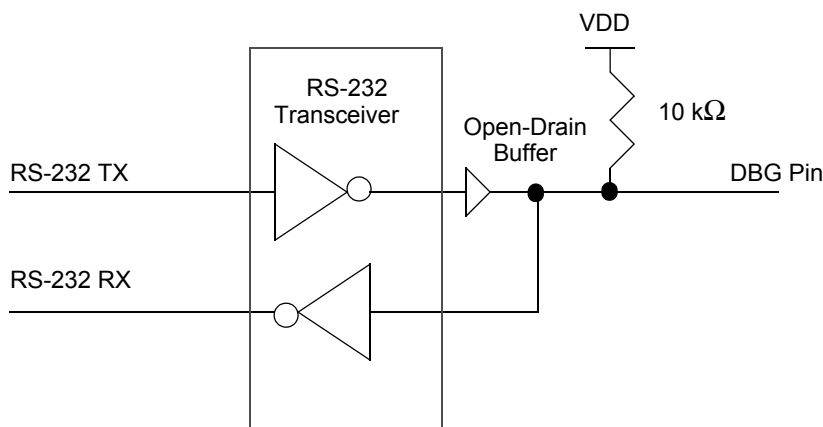

Figure 25. Interfacing the On-Chip Debugger's DBG Pin with an RS-232 Interface (2)

## DEBUG Mode

The operating characteristics of the devices in DEBUG mode are:

- The eZ8 CPU fetch unit stops, idling the eZ8 CPU, unless directed by the OCD to execute specific instructions.
- The system clock operates unless in STOP mode.
- All enabled on-chip peripherals operate unless in STOP mode.
- Automatically exits HALT mode.
- Constantly refreshes the Watchdog Timer, if enabled.

## Entering DEBUG Mode

The operating characteristics of the devices entering DEBUG mode are:

- The device enters DEBUG mode after the eZ8 CPU executes a BRK (Breakpoint) instruction.
- If the DBG pin is held Low during the final clock cycle of system reset, the part enters DEBUG mode immediately (20-/28-pin products only).

► **Note:** *Holding the DBG pin Low for an additional 5000 (minimum) clock cycles after reset (making sure to account for any specified frequency error if using an internal oscillator) prevents a false interpretation of an Autobaud sequence (see [OCD Auto-Baud Detector/Generator](#) on page 176).*

- If the PA2/ $\overline{\text{RESET}}$  pin is held Low while a 32-bit key sequence is issued to the PA0/DBG pin, the DBG feature is unlocked. After releasing PA2/ $\overline{\text{RESET}}$ , it is pulled High. At this point, the PA0/DBG pin may be used to autobaud and cause the device to enter DEBUG mode. See [OCD Unlock Sequence \(8-Pin Devices Only\)](#) on page 178.

### Exiting DEBUG Mode

The device exits DEBUG mode following any of these operations:

- Clearing the DBGMODE bit in the OCD Control Register to 0
- Power-On Reset
- Voltage Brownout reset
- Watchdog Timer reset
- Asserting the  $\overline{\text{RESET}}$  pin Low to initiate a Reset
- Driving the DBG pin Low while the device is in STOP mode initiates a System Reset

### OCD Data Format

The OCD interface uses the asynchronous data format defined for RS-232. Each character transmitted and received by the OCD consists of 1 Start bit, 8 data bits (least-significant bit first), and 1 Stop bit as displayed in [Figure 26](#).

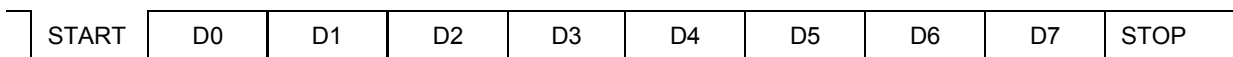

**Figure 26. OCD Data Format**

► **Note:** *When responding to a request for data, the OCD may commence transmitting immediately after receiving the stop bit of an incoming frame. Therefore, when sending the stop bit, the host must not actively drive the DBG pin High for more than 0.5 bit times. It is recommended that, if possible, the host drives the DBG pin using an open drain output to avoid this issue.*

### OCD Auto-Baud Detector/Generator

To run over a range of baud rates (data bits per second) with various system clock frequencies, the On-Chip Debugger contains an Auto-Baud Detector/Generator. After a reset, the OCD is idle until it receives data. The OCD requires that the first character sent from the host is the character 80H. The character 80H has eight continuous bits Low (one Start bit plus 7 data bits), framed between High bits. The Auto-Baud Detector measures this period and sets the OCD Baud Rate Generator accordingly.

The Auto-Baud Detector/Generator is clocked by the system clock. The minimum baud rate is the system clock frequency divided by 512. For optimal operation with asynchronous datastreams, the maximum recommended baud rate is the system clock frequency divided by 8. The maximum possible baud rate for asynchronous datastreams is the system clock frequency divided by 4, but this theoretical maximum is possible only for low noise designs with clean signals. [Table 105](#) lists minimum and recommended maximum baud rates for sample crystal frequencies.

**Table 105. OCD Baud-Rate Limits**

System Clock Frequency (MHz)	Recommended Maximum Baud Rate (Kbps)	Recommended Standard PC Baud Rate (bps)	Minimum Baud Rate (Kbps)
20.0	2500.0	1,843,200	39
1.0	125.0	115,200	1.95
0.032768 (32 kHz)	4.096	2,400	0.064

If the OCD receives a Serial Break (nine or more continuous bits Low) the Auto-Baud Detector/Generator resets. Reconfigure the Auto-Baud Detector/Generator by sending 80H.

## OCD Serial Errors

The On-Chip Debugger can detect any of the following error conditions on the DBG pin:

- Serial Break (a minimum of nine continuous bits Low)
- Framing Error (received `stop` bit is Low)
- Transmit Collision (OCD and host simultaneous transmission detected by the OCD)

When the OCD detects one of these errors, it aborts any command currently in progress, transmits a four character long Serial Break back to the host, and resets the Auto-Baud Detector/Generator. A Framing Error or Transmit Collision may be caused by the host sending a Serial Break to the OCD. Because of the open-drain nature of the interface, returning a Serial Break back to the host only extends the length of the Serial Break if the host releases the Serial Break early.

The host transmits a Serial Break on the DBG pin when first connecting to the Z8 Encore! XP F082A Series devices or when recovering from an error. A Serial Break from the host resets the Auto-Baud Generator/Detector but does not reset the OCD Control register. A Serial Break leaves the device in DEBUG mode if that is the current mode. The OCD is held in Reset until the end of the Serial Break when the DBG pin returns

High. Because of the open-drain nature of the DBG pin, the host can send a Serial Break to the OCD even if the OCD is transmitting a character.

## OCD Unlock Sequence (8-Pin Devices Only)

Because of pin-sharing on the 8-pin device, an unlock sequence must be performed to access the DBG pin. If this sequence is not completed during a system reset, then the PA0/DBG pin functions only as a GPIO pin.

The following sequence unlocks the DBG pin:

1. Hold PA2/ $\overline{\text{RESET}}$  Low.
2. Wait 5ms for the internal reset sequence to complete.
3. Send the following bytes serially to the debug pin:

```
DBG ← 80H (autobaud)
DBG ← EBH
DBG ← 5AH
DBG ← 70H
DBG ← CDH (32-bit unlock key)
```

4. Release PA2/ $\overline{\text{RESET}}$ . The PA0/DBG pin is now identical in function to that of the DBG pin on the 20-/28-pin device. To enter DEBUG mode, re-autobaud and write 80H to the OCD control register (see [On-Chip Debugger Commands](#) on page 179).



**Caution:** *Between Step 3 and Step 4, there is an interval during which the 8-pin device is neither in RESET nor DEBUG mode. If a device has been erased or has not yet been programmed, all program memory bytes contain FFH. The CPU interprets this as an illegal instruction, so some irregular behavior can occur before entering DEBUG mode, and the register values after entering DEBUG mode differs from their specified reset values. However, none of these irregularities prevent programming the Flash memory. Before beginning system debug, it is recommended that some legal code be programmed into the 8-pin device, and that a RESET occurs.*

## Breakpoints

Execution Breakpoints are generated using the BRK instruction (opcode 00H). When the eZ8 CPU decodes a BRK instruction, it signals the On-Chip Debugger. If Breakpoints are enabled, the OCD enters DEBUG mode and idles the eZ8 CPU. If Breakpoints are not enabled, the OCD ignores the BRK signal and the BRK instruction operates as an NOP instruction.

## Breakpoints in Flash Memory

The BRK instruction is opcode 00H, which corresponds to the fully programmed state of a byte in Flash memory. To implement a Breakpoint, write 00H to the required break address, overwriting the current instruction. To remove a Breakpoint, the corresponding page of Flash memory must be erased and reprogrammed with the original data.

## Runtime Counter

The On-Chip Debugger contains a 16-bit Runtime Counter. It counts system clock cycles between Breakpoints. The counter starts counting when the On-Chip Debugger leaves DEBUG mode and stops counting when it enters DEBUG mode again or when it reaches the maximum count of FFFFH.

## On-Chip Debugger Commands

The host communicates to the on-chip debugger by sending OCD commands using the DBG interface. During normal operation, only a subset of the OCD commands are available. In DEBUG mode, all OCD commands become available unless the user code and control registers are protected by programming the Flash Read Protect Option bit (FRP). The Flash Read Protect Option bit prevents the code in memory from being read out of the Z8 Encore! XP F082A Series products. When this option is enabled, several of the OCD commands are disabled. [Table 106](#) on page 184 is a summary of the On-chip debugger commands. Each OCD command is described in further detail in the bulleted list following this table. [Table 106](#) on page 184 also indicates those commands that operate when the device is not in DEBUG mode (normal operation) and those commands that are disabled by programming the Flash Read Protect Option bit.

Debug Command	Command Byte	Enabled when NOT in DEBUG mode?	Disabled by Flash Read Protect Option Bit
Read OCD Revision	00H	Yes	–
Reserved	01H	–	–
Read OCD Status Register	02H	Yes	–
Read Runtime Counter	03H	–	–
Write OCD Control Register	04H	Yes	Cannot clear DBGMODE bit
Read OCD Control Register	05H	Yes	–
Write Program Counter	06H	–	Disabled
Read Program Counter	07H	–	Disabled

Debug Command	Command Byte	Enabled when NOT in DEBUG mode?	Disabled by Flash Read Protect Option Bit
Write Register	08H	–	Only writes of the Flash Memory Control registers are allowed. Additionally, only the Mass Erase command is allowed to be written to the Flash Control register.
Read Register	09H	–	Disabled
Write Program Memory	0AH	–	Disabled
Read Program Memory	0BH	–	Disabled
Write Data Memory	0CH	–	Yes
Read Data Memory	0DH	–	–
Read Program Memory CRC	0EH	–	–
Reserved	0FH	–	–
Step Instruction	10H	–	Disabled
Stuff Instruction	11H	–	Disabled
Execute Instruction	12H	–	Disabled
Reserved	13H–FFH	–	–

In the following bulleted list of OCD Commands, data and commands sent from the host to the On-Chip Debugger are identified by 'DBG ← Command/Data'. Data sent from the On-Chip Debugger back to the host is identified by 'DBG → Data'

- **Read OCD Revision (00H)**—The Read OCD Revision command determines the version of the On-Chip Debugger. If OCD commands are added, removed, or changed, this revision number changes.

```
DBG ← 00H
DBG → OCDRev[15:8] (Major revision number)
DBG → OCDRev[7:0] (Minor revision number)
```

- **Read OCD Status Register (02H)**—The Read OCD Status Register command reads the OCDSTAT register.

```
DBG ← 02H
DBG → OCDSTAT[7:0]
```

- **Read Runtime Counter (03H)**—The Runtime Counter counts system clock cycles in between Breakpoints. The 16-bit Runtime Counter counts up from 0000H and stops at the maximum count of FFFFH. The Runtime Counter is overwritten during the

Write Memory, Read Memory, Write Register, Read Register, Read Memory CRC, Step Instruction, Stuff Instruction, and Execute Instruction commands.

```
DBG ← 03H
DBG → RuntimeCounter[15:8]
DBG → RuntimeCounter[7:0]
```

- **Write OCD Control Register (04H)**—The Write OCD Control Register command writes the data that follows to the OCDCTL register. When the Flash Read Protect Option Bit is enabled, the DBGMODE bit (OCDCTL[7]) can only be set to 1, it cannot be cleared to 0 and the only method of returning the device to normal operating mode is to reset the device.

```
DBG ← 04H
DBG ← OCDCTL[7:0]
```

- **Read OCD Control Register (05H)**—The Read OCD Control Register command reads the value of the OCDCTL register.

```
DBG ← 05H
DBG → OCDCTL[7:0]
```

- **Write Program Counter (06H)**—The Write Program Counter command writes the data that follows to the eZ8 CPU's Program Counter (PC). If the device is not in DEBUG mode or if the Flash Read Protect Option bit is enabled, the Program Counter (PC) values are discarded.

```
DBG ← 06H
DBG ← ProgramCounter[15:8]
DBG ← ProgramCounter[7:0]
```

- **Read Program Counter (07H)**—The Read Program Counter command reads the value in the eZ8 CPU's Program Counter (PC). If the device is not in DEBUG mode or if the Flash Read Protect Option bit is enabled, this command returns FFFFH.

```
DBG ← 07H
DBG → ProgramCounter[15:8]
DBG → ProgramCounter[7:0]
```

- **Write Register (08H)**—The Write Register command writes data to the Register File. Data can be written 1–256 bytes at a time (256 bytes can be written by setting size to 0). If the device is not in DEBUG mode, the address and data values are discarded. If the Flash Read Protect Option bit is enabled, only writes to the Flash Control Registers are allowed and all other register write data values are discarded.

```
DBG ← 08H
DBG ← {4'h0, Register Address[11:8]}
DBG ← Register Address[7:0]
DBG ← Size[7:0]
DBG ← 1-256 data bytes
```



- **Read Register (09H)**—The Read Register command reads data from the Register File. Data can be read 1–256 bytes at a time (256 bytes can be read by setting size to 0). If the device is not in DEBUG mode or if the Flash Read Protect Option bit is enabled, this command returns FFH for all the data values.

```
DBG ← 09H
DBG ← {4'h0, Register Address[11:8]}
DBG ← Register Address[7:0]
DBG ← Size[7:0]
DBG → 1-256 data bytes
```

- **Write Program Memory (0AH)**—The Write Program Memory command writes data to Program Memory. This command is equivalent to the LDC and LDCI instructions. Data can be written 1–65536 bytes at a time (65536 bytes can be written by setting size to 0). The on-chip Flash Controller must be written to and unlocked for the programming operation to occur. If the Flash Controller is not unlocked, the data is discarded. If the device is not in DEBUG mode or if the Flash Read Protect Option bit is enabled, the data is discarded.

```
DBG ← 0AH
DBG ← Program Memory Address[15:8]
DBG ← Program Memory Address[7:0]
DBG ← Size[15:8]
DBG ← Size[7:0]
DBG ← 1-65536 data bytes
```

- **Read Program Memory (0BH)**—The Read Program Memory command reads data from Program Memory. This command is equivalent to the LDC and LDCI instructions. Data can be read 1–65536 bytes at a time (65536 bytes can be read by setting size to 0). If the device is not in DEBUG mode or if the Flash Read Protect Option bit is enabled, this command returns FFH for the data.

```
DBG ← 0BH
DBG ← Program Memory Address[15:8]
DBG ← Program Memory Address[7:0]
DBG ← Size[15:8]
DBG ← Size[7:0]
DBG → 1-65536 data bytes
```

- **Write Data Memory (0CH)**—The Write Data Memory command writes data to Data Memory. This command is equivalent to the LDE and LDEI instructions. Data can be written 1–65536 bytes at a time (65536 bytes can be written by setting size to 0). If the device is not in DEBUG mode or if the Flash Read Protect Option bit is enabled, the data is discarded.

```
DBG ← 0CH
DBG ← Data Memory Address[15:8]
DBG ← Data Memory Address[7:0]
```

DBG ← Size[15:8]  
DBG ← Size[7:0]  
DBG ← 1-65536 data bytes

- **Read Data Memory (0DH)**—The Read Data Memory command reads from Data Memory. This command is equivalent to the LDE and LDEI instructions. Data can be read 1 to 65536 bytes at a time (65536 bytes can be read by setting size to 0). If the device is not in DEBUG mode, this command returns FFH for the data.

DBG ← 0DH  
DBG ← Data Memory Address[15:8]  
DBG ← Data Memory Address[7:0]  
DBG ← Size[15:8]  
DBG ← Size[7:0]  
DBG → 1-65536 data bytes

- **Read Program Memory CRC (0EH)**—The Read Program Memory CRC command computes and returns the Cyclic Redundancy Check (CRC) of Program Memory using the 16-bit CRC-CCITT polynomial. If the device is not in DEBUG mode, this command returns FFFFH for the CRC value. Unlike most other OCD Read commands, there is a delay from issuing of the command until the OCD returns the data. The OCD reads the Program Memory, calculates the CRC value, and returns the result. The delay is a function of the Program Memory size and is approximately equal to the system clock period multiplied by the number of bytes in the Program Memory.

DBG ← 0EH  
DBG → CRC[15:8]  
DBG → CRC[7:0]

- **Step Instruction (10H)**—The Step Instruction command steps one assembly instruction at the current Program Counter (PC) location. If the device is not in DEBUG mode or the Flash Read Protect Option bit is enabled, the OCD ignores this command.

DBG ← 10H

- **Stuff Instruction (11H)**—The Stuff Instruction command steps one assembly instruction and allows specification of the first byte of the instruction. The remaining 0-4 bytes of the instruction are read from Program Memory. This command is useful for stepping over instructions where the first byte of the instruction has been overwritten by a Breakpoint. If the device is not in DEBUG mode or the Flash Read Protect Option bit is enabled, the OCD ignores this command.

DBG ← 11H  
DBG ← opcode[7:0]

- **Execute Instruction (12H)**—The Execute Instruction command allows sending an entire instruction to be executed to the eZ8 CPU. This command can also step over Breakpoints. The number of bytes to send for the instruction depends on the opcode.

If the device is not in DEBUG mode or the Flash Read Protect Option bit is enabled, this command reads and discards one byte.

DBG ← 12H

DBG ← 1-5 byte opcode

## On-Chip Debugger Control Register Definitions

### OCD Control Register

The OCD Control register controls the state of the On-Chip Debugger. This register is used to enter or exit DEBUG mode and to enable the BRK instruction. It can also reset the Z8 Encore! XP<sup>®</sup> F082A Series device.

A reset and stop function can be achieved by writing 81H to this register. A reset and go function can be achieved by writing 41H to this register. If the device is in DEBUG mode, a run function can be implemented by writing 40H to this register.

**Table 106. OCD Control Register (OCDCTL)**

BITS	7	6	5	4	3	2	1	0
FIELD	DBGMODE	BRKEN	DBGACK	Reserved				RST
RESET	0	0	0	0	0	0	0	0
R/W	R/W	R/W	R/W	R	R	R	R	R/W

#### DBGMODE—DEBUG Mode

The device enters DEBUG mode when this bit is 1. When in DEBUG mode, the eZ8 CPU stops fetching new instructions. Clearing this bit causes the eZ8 CPU to restart. This bit is automatically set when a BRK instruction is decoded and Breakpoints are enabled. If the Flash Read Protect Option Bit is enabled, this bit can only be cleared by resetting the device. It cannot be written to 0.

0 = The Z8 Encore! XP F082A Series device is operating in NORMAL mode.

1 = The Z8 Encore! XP F082A Series device is in DEBUG mode.

#### BRKEN—Breakpoint Enable

This bit controls the behavior of the BRK instruction (opcode 00H). By default, Breakpoints are disabled and the BRK instruction behaves similar to an NOP instruction. If this bit is 1, when a BRK instruction is decoded, the DBGMODE bit of the OCDCTL register is automatically set to 1.

0 = Breakpoints are disabled.

1 = Breakpoints are enabled.

**DBGACK—Debug Acknowledge**

This bit enables the debug acknowledge feature. If this bit is set to 1, the OCD sends a Debug Acknowledge character (FFH) to the host when a Breakpoint occurs.

0 = Debug Acknowledge is disabled.

1 = Debug Acknowledge is enabled.

Reserved—Must be 0.

**RST—Reset**

Setting this bit to 1 resets the Z8F04xA family device. The device goes through a normal Power-On Reset sequence with the exception that the On-Chip Debugger is not reset. This bit is automatically cleared to 0 at the end of reset.

0 = No effect.

1 = Reset the Flash Read Protect Option Bit device.

## OCD Status Register

The OCD Status register reports status information about the current state of the debugger and the system.

**Table 107. OCD Status Register (OCDSTAT)**

<b>BITS</b>	<b>7</b>	<b>6</b>	<b>5</b>	<b>4</b>	<b>3</b>	<b>2</b>	<b>1</b>	<b>0</b>
<b>FIELD</b>	DBG	HALT	FRPENB	Reserved				
<b>RESET</b>	0	0	0	0	0	0	0	0
<b>R/W</b>	R	R	R	R	R	R	R	R

**DBG—Debug Status**

0 = NORMAL mode

1 = DEBUG mode

**HALT—HALT Mode**

0 = Not in HALT mode

1 = In HALT mode

**FRPENB—Flash Read Protect Option Bit Enable**

0 = FRP bit enabled, that allows disabling of many OCD commands

1 = FRP bit has no effect

Reserved—Must be 0



# Oscillator Control

The Z8 Encore! XP<sup>®</sup> F082A Series devices uses five possible clocking schemes, each user-selectable:

- Internal precision trimmed RC oscillator (IPO).
- On-chip oscillator using off-chip crystal or resonator.
- On-chip oscillator using external RC network.
- External clock drive.
- On-chip low power Watchdog Timer oscillator.
- Clock failure detection circuitry.

In addition, Z8 Encore! XP F082A Series devices contain clock failure detection and recovery circuitry, allowing continued operation despite a failure of the system clock oscillator.

## Operation

This chapter discusses the logic used to select the system clock and handle primary oscillator failures.

### System Clock Selection

The oscillator control block selects from the available clocks. [Table 108](#) details each clock source and its usage.

**Table 108. Oscillator Configuration and Selection**

Clock Source	Characteristics	Required Setup
Internal Precision RC Oscillator	<ul style="list-style-type: none"> <li>• 32.8 kHz or 5.53 MHz</li> <li>• High accuracy</li> <li>• No external components required</li> </ul>	<ul style="list-style-type: none"> <li>• Unlock and write Oscillator Control Register (OSCCTL) to enable and select oscillator at either 5.53 MHz or 32.8 kHz</li> </ul>
External Crystal/ Resonator	<ul style="list-style-type: none"> <li>• 32 kHz to 20 MHz</li> <li>• Very high accuracy (dependent on crystal or resonator used)</li> <li>• Requires external components</li> </ul>	<ul style="list-style-type: none"> <li>• Configure Flash option bits for correct external oscillator mode</li> <li>• Unlock and write OSCCTL to enable crystal oscillator, wait for it to stabilize and select as system clock (if the XTLDIS option bit has been de-asserted, no waiting is required)</li> </ul>
External RC Oscillator	<ul style="list-style-type: none"> <li>• 32 kHz to 4 MHz</li> <li>• Accuracy dependent on external components</li> </ul>	<ul style="list-style-type: none"> <li>• Configure Flash option bits for correct external oscillator mode</li> <li>• Unlock and write OSCCTL to enable crystal oscillator and select as system clock</li> </ul>
External Clock Drive	<ul style="list-style-type: none"> <li>• 0 to 20 MHz</li> <li>• Accuracy dependent on external clock source</li> </ul>	<ul style="list-style-type: none"> <li>• Write GPIO registers to configure PB3 pin for external clock function</li> <li>• Unlock and write OSCCTL to select external system clock</li> <li>• Apply external clock signal to GPIO</li> </ul>
Internal Watchdog Timer Oscillator	<ul style="list-style-type: none"> <li>• 10 kHz nominal</li> <li>• Low accuracy; no external components required</li> <li>• Very low power consumption</li> </ul>	<ul style="list-style-type: none"> <li>• Enable WDT if not enabled and wait until WDT Oscillator is operating.</li> <li>• Unlock and write Oscillator Control Register (OSCCTL) to enable and select oscillator</li> </ul>



**Caution:** *Unintentional accesses to the oscillator control register can actually stop the chip by switching to a non-functioning oscillator. To prevent this condition, the oscillator control block employs a register unlocking/locking scheme.*

### OSC Control Register Unlocking/Locking

To write the oscillator control register, unlock it by making two writes to the OSCCTL register with the values E7H followed by 18H. A third write to the OSCCTL register changes the value of the actual register and returns the register to a locked state. Any other sequence of oscillator control register writes has no effect. The values written to unlock the register must be ordered correctly, but are not necessarily consecutive. It is possible to write to or read from other registers within the unlocking/locking operation.

When selecting a new clock source, the system clock oscillator failure detection circuitry and the Watchdog Timer oscillator failure circuitry must be disabled. If SOFEN and WOFEN are not disabled prior to a clock switch-over, it is possible to generate an interrupt for a failure of either oscillator. The Failure detection circuitry can be enabled any-time after a successful write of OSCSEL in the OSCCTL register.

The internal precision oscillator is enabled by default. If the user code changes to a different oscillator, it may be appropriate to disable the IPO for power savings. Disabling the IPO does not occur automatically.

## Clock Failure Detection and Recovery

### System Clock Oscillator Failure

The Z8F04xA family devices can generate non-maskable interrupt-like events when the primary oscillator fails. To maintain system function in this situation, the clock failure recovery circuitry automatically forces the Watchdog Timer oscillator to drive the system clock. The Watchdog Timer oscillator must be enabled to allow the recovery. Although this oscillator runs at a much slower speed than the original system clock, the CPU continues to operate, allowing execution of a clock failure vector and software routines that either remedy the oscillator failure or issue a failure alert. This automatic switch-over is not available if the Watchdog Timer is selected as the system clock oscillator. It is also unavailable if the Watchdog Timer oscillator is disabled, though it is not necessary to enable the Watchdog Timer reset function (see [Watchdog Timer](#) on page 91).

The primary oscillator failure detection circuitry asserts if the system clock frequency drops below  $1 \text{ kHz} \pm 50\%$ . If an external signal is selected as the system oscillator, it is possible that a very slow but non-failing clock can generate a failure condition. Under these conditions, do not enable the clock failure circuitry (SOFEN must be deasserted in the OSCCTL register).

### Watchdog Timer Failure

In the event of a Watchdog Timer oscillator failure, a similar non-maskable interrupt-like event is issued. This event does not trigger an attendant clock switch-over, but alerts the CPU of the failure. After a Watchdog Timer failure, it is no longer possible to detect a primary oscillator failure. The failure detection circuitry does not function if the Watchdog Timer is used as the system clock oscillator or if the Watchdog Timer oscillator has been disabled. For either of these cases, it is necessary to disable the detection circuitry by deasserting the WDFEN bit of the OSCCTL register.

The Watchdog Timer oscillator failure detection circuit counts system clocks while looking for a Watchdog Timer clock. The logic counts 8004 system clock cycles before determining that a failure has occurred. The system clock rate determines the speed at which the Watchdog Timer failure can be detected. A very slow system clock results in very slow detection times.





**Caution:** *It is possible to disable the clock failure detection circuitry as well as all functioning clock sources. In this case, the Z8 Encore! XP F082A Series device ceases functioning and can only be recovered by Power-On-Reset.*

## Oscillator Control Register Definitions

### Oscillator Control Register

The Oscillator Control Register (OSCCTL) enables/disables the various oscillator circuits, enables/disables the failure detection/recovery circuitry and selects the primary oscillator, which becomes the system clock.

The Oscillator Control Register must be unlocked before writing. Writing the two step sequence E7H followed by 18H to the Oscillator Control Register unlocks it. The register is locked at successful completion of a register write to the OSCCTL.

**Table 109. Oscillator Control Register (OSCCTL)**

BITS	7	6	5	4	3	2	1	0
FIELD	INTEN	XTLEN	WDTEN	SOFEN	WDFEN	SCKSEL		
RESET	1	0	1	0	0	0	0	0
R/W	R/W	R/W	R/W	R/W	R/W	R/W	R/W	R/W
ADDR	F86H							

INTEN—Internal Precision Oscillator Enable

1 = Internal precision oscillator is enabled

0 = Internal precision oscillator is disabled

XTLEN—Crystal Oscillator Enable; this setting overrides the GPIO register control for PA0 and PA1

1 = Crystal oscillator is enabled

0 = Crystal oscillator is disabled

WDTEN—Watchdog Timer Oscillator Enable

1 = Watchdog Timer oscillator is enabled

0 = Watchdog Timer oscillator is disabled

SOFEN—System Clock Oscillator Failure Detection Enable

1 = Failure detection and recovery of system clock oscillator is enabled

0 = Failure detection and recovery of system clock oscillator is disabled

WDFEN—Watchdog Timer Oscillator Failure Detection Enable

1 = Failure detection of Watchdog Timer oscillator is enabled

0 = Failure detection of Watchdog Timer oscillator is disabled

SCKSEL—System Clock Oscillator Select

000 = Internal precision oscillator functions as system clock at 5.53 MHz

001 = Internal precision oscillator functions as system clock at 32 kHz

010 = Crystal oscillator or external RC oscillator functions as system clock

011 = Watchdog Timer oscillator functions as system

100 = External clock signal on PB3 functions as system clock

101 = Reserved

110 = Reserved

111 = Reserved



# Crystal Oscillator

The products in the Z8 Encore! XP<sup>®</sup> F082A Series contain an on-chip crystal oscillator for use with external crystals with 32 kHz to 20 MHz frequencies. In addition, the oscillator supports external RC networks with oscillation frequencies up to 4 MHz or ceramic resonators with frequencies up to 8 MHz. The on-chip crystal oscillator can be used to generate the primary system clock for the internal eZ8 CPU and the majority of the on-chip peripherals. Alternatively, the X<sub>IN</sub> input pin can also accept a CMOS-level clock input signal (32 kHz–20 MHz). If an external clock generator is used, the X<sub>OUT</sub> pin must be left unconnected. The Z8 Encore! XP F082A Series products do not contain an internal clock divider. The frequency of the signal on the X<sub>IN</sub> input pin determines the frequency of the system clock.

- **Note:** *Although the XIN pin can be used as an input for an external clock generator, the CLKIN pin is better suited for such use (see [System Clock Selection](#) on page 187).*

## Operating Modes

The Z8 Encore! XP F082A Series products support four oscillator modes:

- Minimum power for use with very low frequency crystals (32 kHz–1 MHz).
- Medium power for use with medium frequency crystals or ceramic resonators (0.5 MHz to 8 MHz).
- Maximum power for use with high frequency crystals (8 MHz to 20 MHz).
- On-chip oscillator configured for use with external RC networks (<4 MHz).

The oscillator mode is selected using user-programmable Flash Option Bits. See [Flash Option Bits](#) on page 153 for information.

## Crystal Oscillator Operation

The Flash Option bit XTLDIS controls whether the crystal oscillator is enabled during reset. The crystal may later be disabled after reset if a new oscillator has been selected as the system clock. If the crystal is manually enabled after reset through the OSCCTL register, the user code must wait at least 1000 crystal oscillator cycles for the crystal to stabilize. After this, the crystal oscillator may be selected as the system clock.

- **Note:** *The stabilization time varies depending on the crystal or resonator used, as well as on the feedback network. See [Table 111](#) for transconductance values to compute oscillator stabilization times.*

Figure 27 displays a recommended configuration for connection with an external fundamental-mode, parallel-resonant crystal operating at 20 MHz. Recommended 20 MHz crystal specifications are provided in Table 110. Printed circuit board layout must add no more than 4 pF of stray capacitance to either the X<sub>IN</sub> or X<sub>OUT</sub> pins. If oscillation does not occur, reduce the values of capacitors C<sub>1</sub> and C<sub>2</sub> to decrease loading.

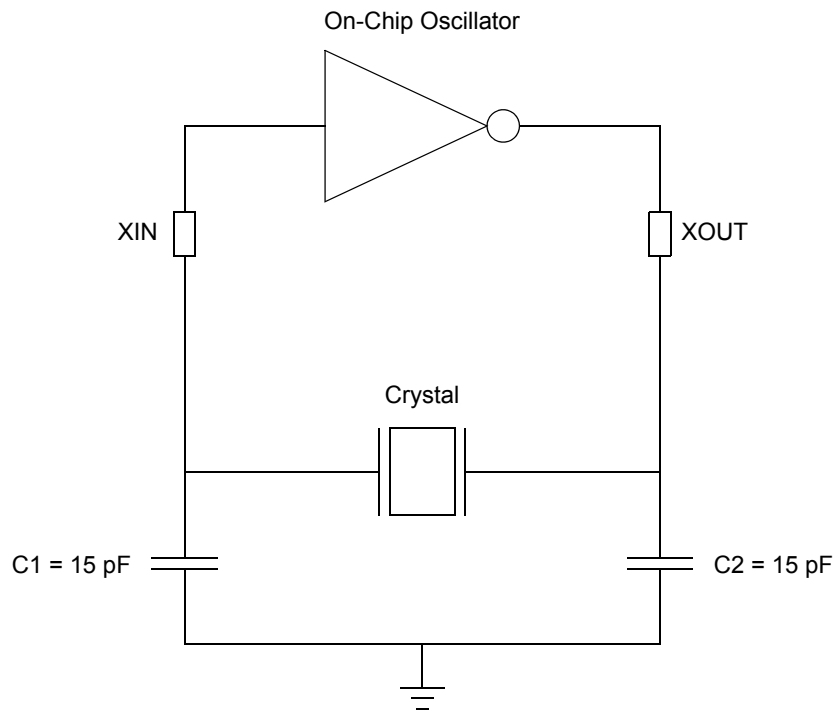

Figure 27. Recommended 20 MHz Crystal Oscillator Configuration

Table 110. Recommended Crystal Oscillator Specifications

Parameter	Value	Units	Comments
Frequency	20	MHz	
Resonance	Parallel		
Mode	Fundamental		
Series Resistance (R <sub>S</sub> )	60	Ω	Maximum
Load Capacitance (C <sub>L</sub> )	30	pF	Maximum
Shunt Capacitance (C <sub>0</sub> )	7	pF	Maximum
Drive Level	1	mW	Maximum

**Table 111. Transconductance Values for Low, Medium, and High Gain Operating Modes**

Mode	Crystal Frequency Range	Function	Transconductance (mA/V)		
			Use this range for calculations		
Low Gain*	32 kHz–1 MHz	Low Power/Frequency Applications	0.02	0.04	0.09
Medium Gain*	0.5 MHz–10 MHz	Medium Power/Frequency Applications	0.84	1.7	3.1
High Gain*	8 MHz–20 MHz	High Power/Frequency Applications	1.1	2.3	4.2

**Note:** \*Printed circuit board layout must not add more than 4 pF of stray capacitance to either XIN or XOUT pins. if no Oscillation occurs, reduce the values of the capacitors C1 and C2 to decrease the loading.

## Oscillator Operation with an External RC Network

Figure 28 displays a recommended configuration for connection with an external resistor-capacitor (RC) network.

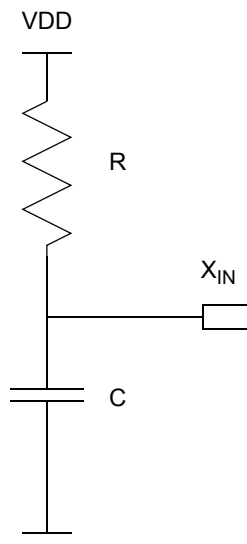

**Figure 28. Connecting the On-Chip Oscillator to an External RC Network**

An external resistance value of 45 kΩ is recommended for oscillator operation with an external RC network. The minimum resistance value to ensure operation is 40 kΩ. The typical oscillator frequency can be estimated from the values of the resistor (*R* in kΩ) and capacitor (*C* in pF) elements using the following equation:

$$\text{Oscillator Frequency (kHz)} = \frac{1 \times 10^6}{(0.4 \times R \times C) + (4 \times C)}$$

Figure 29 displays the typical (3.3 V and 25 °C) oscillator frequency as a function of the capacitor ( $C$  in pF) employed in the RC network assuming a 45 K $\Omega$  external resistor. For very small values of  $C$ , the parasitic capacitance of the oscillator XIN pin and the printed circuit board must be included in the estimation of the oscillator frequency.

It is possible to operate the RC oscillator using only the parasitic capacitance of the package and printed circuit board. To minimize sensitivity to external parasitics, external capacitance values in excess of 20 pF are recommended.

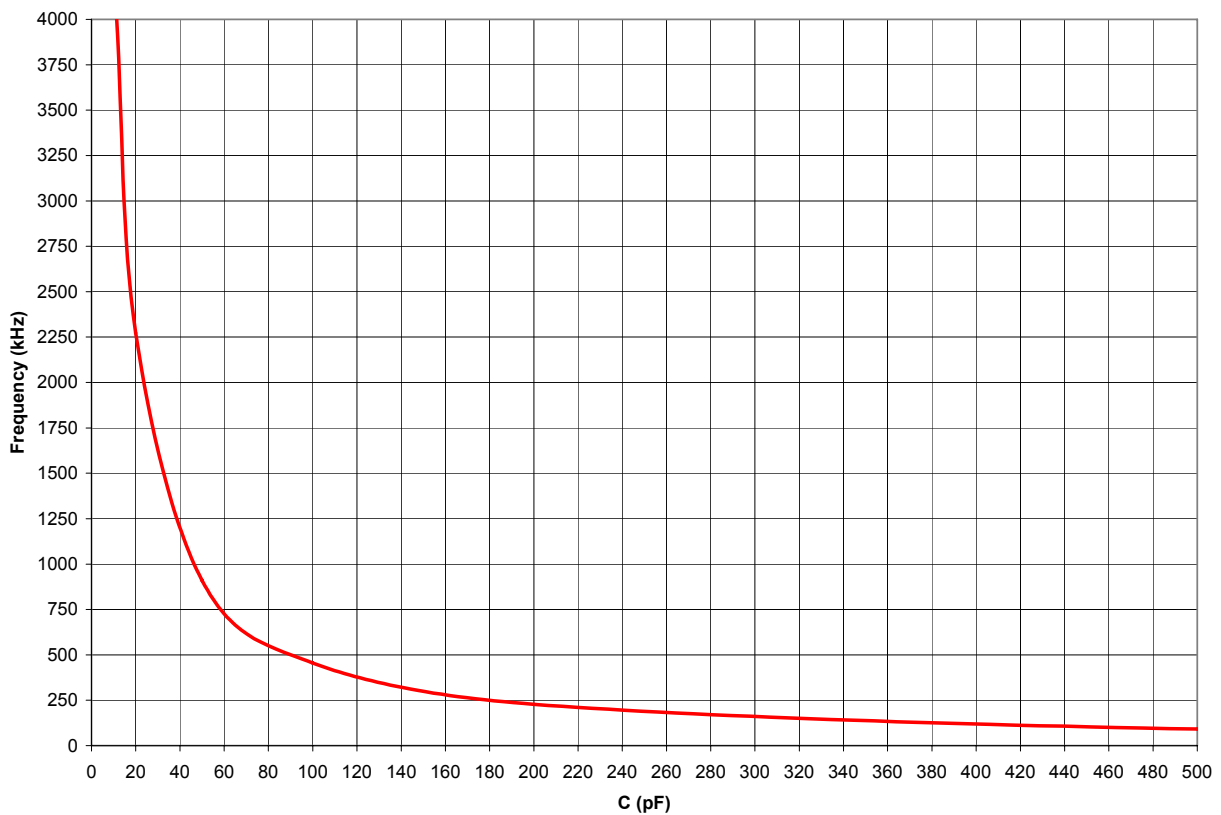

**Figure 29. Typical RC Oscillator Frequency as a Function of the External Capacitance with a 45 k $\Omega$  Resistor**



**Caution:**

*When using the external RC oscillator mode, the oscillator can stop oscillating if the power supply drops below 2.7 V, but before the power supply drops to the Voltage Brownout threshold. The oscillator resumes oscillation when the supply voltage exceeds 2.7 V.*

# Internal Precision Oscillator

The internal precision oscillator (IPO) is designed for use without external components. You can either manually trim the oscillator for a non-standard frequency or use the automatic factory-trimmed version to achieve a 5.53 MHz frequency. IPO features include:

- On-chip RC oscillator that does not require external components
- Output frequency of either 5.53 MHz or 32.8 kHz (contains both a fast and a slow mode)
- Trimmed through Flash option bits with user override
- Elimination of crystals or ceramic resonators in applications where very high timing accuracy is not required

## Operation

An 8-bit trimming register, incorporated into the design, compensates for absolute variation of oscillator frequency. Once trimmed the oscillator frequency is stable and does not require subsequent calibration. Trimming is performed during manufacturing and is not necessary for you to repeat unless a frequency other than 5.53 MHz (fast mode) or 32.8 kHz (slow mode) is required. This trimming is done at +30 °C and a supply voltage of 3.3 V, so accuracy of this operating point is optimal.

If not used, the IPO can be disabled by the Oscillator Control register (see [Oscillator Control Register Definitions](#) on page 190).

By default, the oscillator frequency is set by the factory trim value stored in the write-protected Flash information page. However, the user code can override these trim values as described in [Trim Bit Address Space](#) on page 158.

Select one of two frequencies for the oscillator: 5.53 MHz and 32.8 kHz, using the OSCSEL bits in the [Oscillator Control](#) on page 187.





# eZ8 CPU Instruction Set

## Assembly Language Programming Introduction

The eZ8 CPU assembly language provides a means for writing an application program without concern for actual memory addresses or machine instruction formats. A program written in assembly language is called a source program. Assembly language allows the use of symbolic addresses to identify memory locations. It also allows mnemonic codes (opcodes and operands) to represent the instructions themselves. The opcodes identify the instruction while the operands represent memory locations, registers, or immediate data values.

Each assembly language program consists of a series of symbolic commands called statements. Each statement can contain labels, operations, operands and comments.

Labels can be assigned to a particular instruction step in a source program. The label identifies that step in the program as an entry point for use by other instructions.

The assembly language also includes assembler directives that supplement the machine instruction. The assembler directives, or pseudo-ops, are not translated into a machine instruction. Rather, the pseudo-ops are interpreted as directives that control or assist the assembly process.

The source program is processed (assembled) by the assembler to obtain a machine language program called the object code. The object code is executed by the eZ8 CPU. An example segment of an assembly language program is detailed in the following example.

### Assembly Language Source Program Example

```
JP START      ; Everything after the semicolon is a comment.

START:        ; A label called 'START'. The first instruction (JP START) in this
              ; example causes program execution to jump to the point within the
              ; program where the START label occurs.

LD R4, R7     ; A Load (LD) instruction with two operands. The first operand,
              ; Working Register R4, is the destination. The second operand,
              ; Working Register R7, is the source. The contents of R7 is
              ; written into R4.

LD 234H, %#01 ; Another Load (LD) instruction with two operands.
              ; The first operand, Extended Mode Register Address 234H,
              ; identifies the destination. The second operand, Immediate Data
              ; value 01H, is the source. The value 01H is written into the
              ; Register at address 234H.
```

## Assembly Language Syntax

For proper instruction execution, eZ8 CPU assembly language syntax requires that the operands be written as ‘destination, source’. After assembly, the object code usually has the operands in the order ‘source, destination’, but ordering is opcode-dependent. The following instruction examples illustrate the format of some basic assembly instructions and the resulting object code produced by the assembler. This binary format must be followed if manual program coding is preferred or if you intend to implement your own assembler.

**Example 1:** If the contents of Registers 43H and 08H are added and the result is stored in 43H, the assembly syntax and resulting object code is:

**Table 112. Assembly Language Syntax Example 1**

<b>Assembly Language Code</b>	ADD	43H,	08H	(ADD dst, src)
<b>Object Code</b>	04	08	43	(OPC src, dst)

**Example 2:** In general, when an instruction format requires an 8-bit register address, that address can specify any register location in the range 0–255 or, using Escaped Mode Addressing, a Working Register R0–R15. If the contents of Register 43H and Working Register R8 are added and the result is stored in 43H, the assembly syntax and resulting object code is:

**Table 113. Assembly Language Syntax Example 2**

<b>Assembly Language Code</b>	ADD	43H,	R8	(ADD dst, src)
<b>Object Code</b>	04	E8	43	(OPC src, dst)

See the device-specific Product Specification to determine the exact register file range available. The register file size varies, depending on the device type.

## eZ8 CPU Instruction Notation

In the eZ8 CPU Instruction Summary and Description sections, the operands, condition codes, status flags, and address modes are represented by a notational shorthand that is described in [Table 114](#).

**Table 114. Notational Shorthand**

Notation	Description	Operand	Range
b	Bit	b	b represents a value from 0 to 7 (000B to 111B).
cc	Condition Code	—	Refer to Condition Codes section in the <i>eZ8 CPU Core User Manual (UM0128)</i> .
DA	Direct Address	Addr	Addr. represents a number in the range of 0000H to FFFFH
ER	Extended Addressing Register	Reg	Reg. represents a number in the range of 000H to FFFH
IM	Immediate Data	#Data	Data is a number between 00H to FFH
Ir	Indirect Working Register	@Rn	n = 0–15
IR	Indirect Register	@Reg	Reg. represents a number in the range of 00H to FFH
Irr	Indirect Working Register Pair	@RRp	p = 0, 2, 4, 6, 8, 10, 12, or 14
IRR	Indirect Register Pair	@Reg	Reg. represents an even number in the range 00H to FEH
p	Polarity	p	Polarity is a single bit binary value of either 0B or 1B.
r	Working Register	Rn	n = 0 – 15
R	Register	Reg	Reg. represents a number in the range of 00H to FFH
RA	Relative Address	X	X represents an index in the range of +127 to –128 which is an offset relative to the address of the next instruction
rr	Working Register Pair	RRp	p = 0, 2, 4, 6, 8, 10, 12, or 14
RR	Register Pair	Reg	Reg. represents an even number in the range of 00H to FEH
Vector	Vector Address	Vector	Vector represents a number in the range of 00H to FFH
X	Indexed	#Index	The register or register pair to be indexed is offset by the signed Index value (#Index) in a +127 to -128 range.

[Table 115](#) lists additional symbols that are used throughout the Instruction Summary and Instruction Set Description sections.

**Table 115. Additional Symbols**

Symbol	Definition
dst	Destination Operand
src	Source Operand
@	Indirect Address Prefix
SP	Stack Pointer
PC	Program Counter
FLAGS	Flags Register
RP	Register Pointer
#	Immediate Operand Prefix
B	Binary Number Suffix
%	Hexadecimal Number Prefix
H	Hexadecimal Number Suffix

Assignment of a value is indicated by an arrow. For example,

$$\text{dst} \leftarrow \text{dst} + \text{src}$$

indicates the source data is added to the destination data and the result is stored in the destination location.

## eZ8 CPU Instruction Classes

eZ8 CPU instructions can be divided functionally into the following groups:

- Arithmetic
- Bit Manipulation
- Block Transfer
- CPU Control
- Load
- Logical
- Program Control
- Rotate and Shift

Table 116 through Table 123 lists the instructions belonging to each group and the number of operands required for each instruction. Some instructions appear in more than one table as these instruction can be considered as a subset of more than one category. Within these tables, the source operand is identified as ‘src’, the destination operand is ‘dst’ and a condition code is ‘cc’.

**Table 116. Arithmetic Instructions**

<b>Mnemonic</b>	<b>Operands</b>	<b>Instruction</b>
ADC	dst, src	Add with Carry
ADCX	dst, src	Add with Carry using Extended Addressing
ADD	dst, src	Add
ADDX	dst, src	Add using Extended Addressing
CP	dst, src	Compare
CPC	dst, src	Compare with Carry
CPCX	dst, src	Compare with Carry using Extended Addressing
CPX	dst, src	Compare using Extended Addressing
DA	dst	Decimal Adjust
DEC	dst	Decrement
DECW	dst	Decrement Word
INC	dst	Increment
INCW	dst	Increment Word
MULT	dst	Multiply
SBC	dst, src	Subtract with Carry
SBCX	dst, src	Subtract with Carry using Extended Addressing
SUB	dst, src	Subtract
SUBX	dst, src	Subtract using Extended Addressing

**Table 117. Bit Manipulation Instructions**

<b>Mnemonic</b>	<b>Operands</b>	<b>Instruction</b>
BCLR	bit, dst	Bit Clear
BIT	p, bit, dst	Bit Set or Clear
BSET	bit, dst	Bit Set
BSWAP	dst	Bit Swap
CCF	—	Complement Carry Flag
RCF	—	Reset Carry Flag
SCF	—	Set Carry Flag
TCM	dst, src	Test Complement Under Mask
TCMX	dst, src	Test Complement Under Mask using Extended Addressing
TM	dst, src	Test Under Mask
TMX	dst, src	Test Under Mask using Extended Addressing

**Table 118. Block Transfer Instructions**

<b>Mnemonic</b>	<b>Operands</b>	<b>Instruction</b>
LDCI	dst, src	Load Constant to/from Program Memory and Auto-Increment Addresses
LDEI	dst, src	Load External Data to/from Data Memory and Auto-Increment Addresses

**Table 119. CPU Control Instructions**

<b>Mnemonic</b>	<b>Operands</b>	<b>Instruction</b>
ATM	—	Atomic Execution
CCF	—	Complement Carry Flag
DI	—	Disable Interrupts
EI	—	Enable Interrupts
HALT	—	Halt Mode
NOP	—	No Operation
RCF	—	Reset Carry Flag

**Table 119. CPU Control Instructions (Continued)**

Mnemonic	Operands	Instruction
SCF	—	Set Carry Flag
SRP	src	Set Register Pointer
STOP	—	STOP Mode
WDT	—	Watchdog Timer Refresh

**Table 120. Load Instructions**

Mnemonic	Operands	Instruction
CLR	dst	Clear
LD	dst, src	Load
LDC	dst, src	Load Constant to/from Program Memory
LDCI	dst, src	Load Constant to/from Program Memory and Auto-Increment Addresses
LDE	dst, src	Load External Data to/from Data Memory
LDEI	dst, src	Load External Data to/from Data Memory and Auto-Increment Addresses
LDWX	dst, src	Load Word using Extended Addressing
LDX	dst, src	Load using Extended Addressing
LEA	dst, X(src)	Load Effective Address
POP	dst	Pop
POPX	dst	Pop using Extended Addressing
PUSH	src	Push
PUSHX	src	Push using Extended Addressing

**Table 121. Logical Instructions**

Mnemonic	Operands	Instruction
AND	dst, src	Logical AND
ANDX	dst, src	Logical AND using Extended Addressing
COM	dst	Complement
OR	dst, src	Logical OR



**Table 121. Logical Instructions (Continued)**

Mnemonic	Operands	Instruction
ORX	dst, src	Logical OR using Extended Addressing
XOR	dst, src	Logical Exclusive OR
XORX	dst, src	Logical Exclusive OR using Extended Addressing

**Table 122. Program Control Instructions**

Mnemonic	Operands	Instruction
BRK	—	On-Chip Debugger Break
BTJ	p, bit, src, DA	Bit Test and Jump
BTJNZ	bit, src, DA	Bit Test and Jump if Non-Zero
BTJZ	bit, src, DA	Bit Test and Jump if Zero
CALL	dst	Call Procedure
DJNZ	dst, src, RA	Decrement and Jump Non-Zero
IRET	—	Interrupt Return
JP	dst	Jump
JP cc	dst	Jump Conditional
JR	DA	Jump Relative
JR cc	DA	Jump Relative Conditional
RET	—	Return
TRAP	vector	Software Trap

**Table 123. Rotate and Shift Instructions**

Mnemonic	Operands	Instruction
BSWAP	dst	Bit Swap
RL	dst	Rotate Left
RLC	dst	Rotate Left through Carry
RR	dst	Rotate Right
RRC	dst	Rotate Right through Carry

**Table 123. Rotate and Shift Instructions (Continued)**

Mnemonic	Operands	Instruction
SRA	dst	Shift Right Arithmetic
SRL	dst	Shift Right Logical
SWAP	dst	Swap Nibbles

## eZ8 CPU Instruction Summary

Table 124 summarizes the eZ8 CPU instructions. The table identifies the addressing modes employed by the instruction, the effect upon the Flags register, the number of CPU clock cycles required for the instruction fetch, and the number of CPU clock cycles required for the instruction execution.

**Table 124. eZ8 CPU Instruction Summary**

Assembly Mnemonic	Symbolic Operation	Address Mode		Opcode(s) (Hex)	Flags						Fetch Cycles	Instr. Cycles
		dst	src		C	Z	S	V	D	H		
ADC dst, src	$dst \leftarrow dst + src + C$	r	r	12	*	*	*	*	0	*	2	3
		r	lr	13							2	4
		R	R	14							3	3
		R	IR	15							3	4
		R	IM	16							3	3
		IR	IM	17							3	4
ADCX dst, src	$dst \leftarrow dst + src + C$	ER	ER	18	*	*	*	*	0	*	4	3
		ER	IM	19							4	3
ADD dst, src	$dst \leftarrow dst + src$	r	r	02	*	*	*	*	0	*	2	3
		r	lr	03							2	4
		R	R	04							3	3
		R	IR	05							3	4
		R	IM	06							3	3
		IR	IM	07							3	4
ADDX dst, src	$dst \leftarrow dst + src$	ER	ER	08	*	*	*	*	0	*	4	3
		ER	IM	09							4	3
Flags Notation:	* = Value is a function of the result of the operation. - = Unaffected X = Undefined				0 = Reset to 0 1 = Set to 1							



Table 124. eZ8 CPU Instruction Summary (Continued)

Assembly Mnemonic	Symbolic Operation	Address Mode		Opcode(s) (Hex)	Flags						Fetch Cycles	Instr. Cycles
		dst	src		C	Z	S	V	D	H		
AND dst, src	dst ← dst AND src	r	r	52	-	*	*	0	-	-	2	3
		r	lr	53							2	4
		R	R	54							3	3
		R	IR	55							3	4
		R	IM	56							3	3
		IR	IM	57							3	4
ANDX dst, src	dst ← dst AND src	ER	ER	58	-	*	*	0	-	-	4	3
		ER	IM	59							4	3
ATM	Block all interrupt and DMA requests during execution of the next 3 instructions			2F	-	-	-	-	-	-	1	2
BCLR bit, dst	dst[bit] ← 0	r		E2	-	-	-	-	-	-	2	2
BIT p, bit, dst	dst[bit] ← p	r		E2	-	-	-	-	-	-	2	2
BRK	Debugger Break			00	-	-	-	-	-	-	1	1
BSET bit, dst	dst[bit] ← 1	r		E2	-	-	-	-	-	-	2	2
BSWAP dst	dst[7:0] ← dst[0:7]	R		D5	X	*	*	0	-	-	2	2
BTJ p, bit, src, dst	if src[bit] = p PC ← PC + X		r	F6	-	-	-	-	-	-	3	3
			lr	F7							3	4
BTJNZ bit, src, dst	if src[bit] = 1 PC ← PC + X		r	F6	-	-	-	-	-	-	3	3
			lr	F7							3	4
BTJZ bit, src, dst	if src[bit] = 0 PC ← PC + X		r	F6	-	-	-	-	-	-	3	3
			lr	F7							3	4
CALL dst	SP ← SP - 2 @SP ← PC PC ← dst	IRR		D4	-	-	-	-	-	-	2	6
		DA		D6							3	3
CCF	C ← ~C			EF	*	-	-	-	-	-	1	2
CLR dst	dst ← 00H	R		B0	-	-	-	-	-	-	2	2
		IR		B1							2	3
Flags Notation:	* = Value is a function of the result of the operation. - = Unaffected X = Undefined				0 = Reset to 0 1 = Set to 1							



Table 124. eZ8 CPU Instruction Summary (Continued)

Assembly Mnemonic	Symbolic Operation	Address Mode		Opcode(s) (Hex)	Flags						Fetch Cycles	Instr. Cycles
		dst	src		C	Z	S	V	D	H		
COM dst	dst ← ~dst	R		60	-	*	*	0	-	-	2	2
		IR		61							2	3
CP dst, src	dst - src	r	r	A2	*	*	*	*	-	-	2	3
		r	lr	A3							2	4
		R	R	A4							3	3
		R	IR	A5							3	4
		R	IM	A6							3	3
		IR	IM	A7							3	4
CPC dst, src	dst - src - C	r	r	1F A2	*	*	*	*	-	-	3	3
		r	lr	1F A3							3	4
		R	R	1F A4							4	3
		R	IR	1F A5							4	4
		R	IM	1F A6							4	3
		IR	IM	1F A7							4	4
CPCX dst, src	dst - src - C	ER	ER	1F A8	*	*	*	*	-	-	5	3
		ER	IM	1F A9							5	3
CPX dst, src	dst - src	ER	ER	A8	*	*	*	*	-	-	4	3
		ER	IM	A9							4	3
DA dst	dst ← DA(dst)	R		40	*	*	*	X	-	-	2	2
		IR		41							2	3
DEC dst	dst ← dst - 1	R		30	-	*	*	*	-	-	2	2
		IR		31							2	3
DECW dst	dst ← dst - 1	RR		80	-	*	*	*	-	-	2	5
		IRR		81							2	6
DI	IRQCTL[7] ← 0			8F	-	-	-	-	-	-	1	2
DJNZ dst, RA	dst ← dst - 1 if dst ≠ 0 PC ← PC + X	r		0A-FA	-	-	-	-	-	-	2	3
EI	IRQCTL[7] ← 1			9F	-	-	-	-	-	-	1	2
Flags Notation:	* = Value is a function of the result of the operation. - = Unaffected X = Undefined				0 = Reset to 0 1 = Set to 1							



Table 124. eZ8 CPU Instruction Summary (Continued)

Assembly Mnemonic	Symbolic Operation	Address Mode		Opcode(s) (Hex)	Flags						Fetch Cycles	Instr. Cycles
		dst	src		C	Z	S	V	D	H		
HALT	Halt Mode			7F	-	-	-	-	-	-	1	2
INC dst	dst ← dst + 1	R		20	-	*	*	-	-	-	2	2
		IR		21							2	3
		r		0E-FE							1	2
INCW dst	dst ← dst + 1	RR		A0	-	*	*	*	-	-	2	5
		IRR		A1							2	6
IRET	FLAGS ← @SP SP ← SP + 1 PC ← @SP SP ← SP + 2 IRQCTL[7] ← 1			BF	*	*	*	*	*	*	1	5
JP dst	PC ← dst	DA		8D	-	-	-	-	-	-	3	2
		IRR		C4							2	3
JP cc, dst	if cc is true PC ← dst	DA		0D-FD	-	-	-	-	-	-	3	2
JR dst	PC ← PC + X	DA		8B	-	-	-	-	-	-	2	2
JR cc, dst	if cc is true PC ← PC + X	DA		0B-FB	-	-	-	-	-	-	2	2
LD dst, rc	dst ← src	r	IM	0C-FC	-	-	-	-	-	-	2	2
		r	X(r)	C7							3	3
		X(r)	r	D7							3	4
		r	lr	E3							2	3
		R	R	E4							3	2
		R	IR	E5							3	4
		R	IM	E6							3	2
		IR	IM	E7							3	3
		lr	r	F3							2	3
		IR	R	F5							3	3
Flags Notation:	* = Value is a function of the result of the operation. - = Unaffected X = Undefined		0 = Reset to 0 1 = Set to 1									



Table 124. eZ8 CPU Instruction Summary (Continued)

Assembly Mnemonic	Symbolic Operation	Address Mode		Opcode(s) (Hex)	Flags						Fetch Cycles	Instr. Cycles
		dst	src		C	Z	S	V	D	H		
LDC dst, src	dst ← src	r	lrr	C2	-	-	-	-	-	-	2	5
		lr	lrr	C5							2	9
		lrr	r	D2							2	5
LDCI dst, src	dst ← src r ← r + 1 rr ← rr + 1	lr	lrr	C3	-	-	-	-	-	-	2	9
		lrr	lr	D3							2	9
LDE dst, src	dst ← src	r	lrr	82	-	-	-	-	-	-	2	5
		lrr	r	92							2	5
LDEI dst, src	dst ← src r ← r + 1 rr ← rr + 1	lr	lrr	83	-	-	-	-	-	-	2	9
		lrr	lr	93							2	9
LDWX dst, src	dst ← src	ER	ER	1FE8	-	-	-	-	-	-	5	4
LDX dst, src	dst ← src	r	ER	84	-	-	-	-	-	-	3	2
		lr	ER	85							3	3
		R	IRR	86							3	4
		IR	IRR	87							3	5
		r	X(rr)	88							3	4
		X(rr)	r	89							3	4
		ER	r	94							3	2
		ER	lr	95							3	3
		IRR	R	96							3	4
		IRR	IR	97							3	5
		ER	ER	E8							4	2
LEA dst, X(src)	dst ← src + X	r	X(r)	98	-	-	-	-	-	-	3	3
		rr	X(rr)	99							3	5
MULT dst	dst[15:0] ← dst[15:8] * dst[7:0]	RR		F4	-	-	-	-	-	-	2	8
NOP	No operation			0F	-	-	-	-	-	-	1	2
Flags Notation:	* = Value is a function of the result of the operation. - = Unaffected X = Undefined				0 = Reset to 0 1 = Set to 1							

**Table 124. eZ8 CPU Instruction Summary (Continued)**

Assembly Mnemonic	Symbolic Operation	Address Mode		Opcode(s) (Hex)	Flags						Fetch Cycles	Instr. Cycles
		dst	src		C	Z	S	V	D	H		
OR dst, src	dst ← dst OR src	r	r	42	-	*	*	0	-	-	2	3
		r	lr	43							2	4
		R	R	44							3	3
		R	IR	45							3	4
		R	IM	46							3	3
		IR	IM	47							3	4
ORX dst, src	dst ← dst OR src	ER	ER	48	-	*	*	0	-	-	4	3
		ER	IM	49							4	3
POP dst	dst ← @SP SP ← SP + 1	R		50	-	-	-	-	-	-	2	2
		IR		51							2	3
POPX dst	dst ← @SP SP ← SP + 1	ER		D8	-	-	-	-	-	-	3	2
PUSH src	SP ← SP - 1 @SP ← src	R		70	-	-	-	-	-	-	2	2
		IR		71							2	3
		IM		IF70							3	2
PUSHX src	SP ← SP - 1 @SP ← src	ER		C8	-	-	-	-	-	-	3	2
RCF	C ← 0			CF	0	-	-	-	-	-	1	2
RET	PC ← @SP SP ← SP + 2			AF	-	-	-	-	-	-	1	4
RL dst		R		90	*	*	*	*	-	-	2	2
		IR		91							2	3
RLC dst		R		10	*	*	*	*	-	-	2	2
		IR		11							2	3
Flags Notation:	* = Value is a function of the result of the operation.		0 = Reset to 0									
	- = Unaffected											
	X = Undefined											
											1 = Set to 1	

Table 124. eZ8 CPU Instruction Summary (Continued)

Assembly Mnemonic	Symbolic Operation	Address Mode		Opcode(s) (Hex)	Flags						Fetch Cycles	Instr. Cycles
		dst	src		C	Z	S	V	D	H		
RR dst		R		E0	*	*	*	*	-	-	2	2
		IR		E1							2	3
RRC dst		R		C0	*	*	*	*	-	-	2	2
		IR		C1							2	3
SBC dst, src	dst ← dst - src - C	r	r	32	*	*	*	*	1	*	2	3
		r	lr	33							2	4
		R	R	34							3	3
		R	IR	35							3	4
		R	IM	36							3	3
		IR	IM	37							3	4
SBCX dst, src	dst ← dst - src - C	ER	ER	38	*	*	*	*	1	*	4	3
		ER	IM	39							4	3
SCF	C ← 1			DF	1	-	-	-	-	-	1	2
SRA dst		R		D0	*	*	*	0	-	-	2	2
		IR		D1							2	3
SRL dst		R		1F C0	*	*	0	*	-	-	3	2
		IR		1F C1							3	3
SRP src	RP ← src		IM	01	-	-	-	-	-	-	2	2
STOP	STOP Mode			6F	-	-	-	-	-	-	1	2
SUB dst, src	dst ← dst - src	r	r	22	*	*	*	*	1	*	2	3
		r	lr	23							2	4
		R	R	24							3	3
		R	IR	25							3	4
		R	IM	26							3	3
		IR	IM	27							3	4

Flags Notation: \* = Value is a function of the result of the operation. 0 = Reset to 0  
 - = Unaffected - = Unaffected 1 = Set to 1  
 X = Undefined



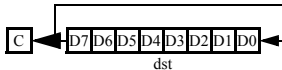
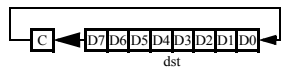

Table 124. eZ8 CPU Instruction Summary (Continued)

Assembly Mnemonic	Symbolic Operation	Address Mode		Opcode(s) (Hex)	Flags						Fetch Cycles	Instr. Cycles
		dst	src		C	Z	S	V	D	H		
SUBX dst, src	dst ← dst – src	ER	ER	28	*	*	*	*	1	*	4	3
		ER	IM	29							4	3
SWAP dst	dst[7:4] ↔ dst[3:0]	R		F0	X	*	*	X	–	–	2	2
		IR		F1							2	3
TCM dst, src	(NOT dst) AND src	r	r	62	–	*	*	0	–	–	2	3
		r	lr	63							2	4
		R	R	64							3	3
		R	IR	65							3	4
		R	IM	66							3	3
		IR	IM	67							3	4
TCMX dst, src	(NOT dst) AND src	ER	ER	68	–	*	*	0	–	–	4	3
		ER	IM	69							4	3
TM dst, src	dst AND src	r	r	72	–	*	*	0	–	–	2	3
		r	lr	73							2	4
		R	R	74							3	3
		R	IR	75							3	4
		R	IM	76							3	3
		IR	IM	77							3	4
TMX dst, src	dst AND src	ER	ER	78	–	*	*	0	–	–	4	3
		ER	IM	79							4	3
TRAP Vector	SP ← SP – 2 @SP ← PC SP ← SP – 1 @SP ← FLAGS PC ← @Vector		Vector	F2	–	–	–	–	–	–	2	6
WDT				5F	–	–	–	–	–	–	1	2
Flags Notation:	* = Value is a function of the result of the operation. – = Unaffected X = Undefined					0 = Reset to 0 1 = Set to 1						

**Table 124. eZ8 CPU Instruction Summary (Continued)**

Assembly Mnemonic	Symbolic Operation	Address Mode		Opcode(s) (Hex)	Flags						Fetch Cycles	Instr. Cycles
		dst	src		C	Z	S	V	D	H		
XOR dst, src	dst ← dst XOR src	r	r	B2	-	*	*	0	-	-	2	3
		r	lr	B3							2	4
		R	R	B4							3	3
		R	IR	B5							3	4
		R	IM	B6							3	3
		IR	IM	B7							3	4
XORX dst, src	dst ← dst XOR src	ER	ER	B8	-	*	*	0	-	-	4	3
		ER	IM	B9							4	3
Flags Notation:	* = Value is a function of the result of the operation.				0 = Reset to 0							
	- = Unaffected				1 = Set to 1							
	X = Undefined											

# Opcode Maps

A description of the opcode map data and the abbreviations are provided in [Figure 30](#). [Figure 31](#) and [Figure 32](#) displays the eZ8 CPU instructions. [Table 125](#) lists Opcode Map abbreviations.

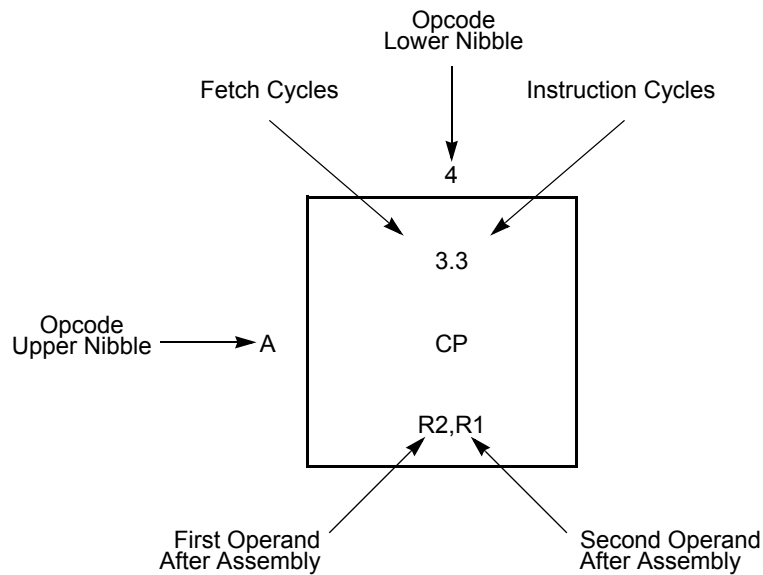

**Figure 30. Opcode Map Cell Description**

**Table 125. Opcode Map Abbreviations**

<b>Abbreviation</b>	<b>Description</b>	<b>Abbreviation</b>	<b>Description</b>
b	Bit position	IRR	Indirect Register Pair
cc	Condition code	p	Polarity (0 or 1)
X	8-bit signed index or displacement	r	4-bit Working Register
DA	Destination address	R	8-bit register
ER	Extended Addressing register	r1, R1, lr1, lrr1, IR1, rr1, RR1, IRR1, ER1	Destination address
IM	Immediate data value	r2, R2, lr2, lrr2, IR2, rr2, RR2, IRR2, ER2	Source address
lr	Indirect Working Register	RA	Relative
IR	Indirect register	rr	Working Register Pair
lrr	Indirect Working Register Pair	RR	Register Pair

		Lower Nibble (Hex)																
		0	1	2	3	4	5	6	7	8	9	A	B	C	D	E	F	
Upper Nibble (Hex)	0	1.1 <b>BRK</b>	2.2 <b>SRP</b> IM	2.3 <b>ADD</b> r1,r2	2.4 <b>ADD</b> r1,lr2	3.3 <b>ADD</b> R2,R1	3.4 <b>ADD</b> IR2,R1	3.3 <b>ADD</b> R1,IM	3.4 <b>ADD</b> IR1,IM	4.3 <b>ADDX</b> ER2,ER1	4.3 <b>ADDX</b> IM,ER1	2.3 <b>DJNZ</b> r1,X	2.2 <b>JR</b> cc,X	2.2 <b>LD</b> r1,IM	3.2 <b>JP</b> cc,DA	1.2 <b>INC</b> r1	1.2 <b>NOP</b>	
	1	2.2 <b>RLC</b> R1	2.3 <b>RLC</b> IR1	2.3 <b>ADC</b> r1,r2	2.4 <b>ADC</b> r1,lr2	3.3 <b>ADC</b> R2,R1	3.4 <b>ADC</b> IR2,R1	3.3 <b>ADC</b> R1,IM	3.4 <b>ADC</b> IR1,IM	4.3 <b>ADCX</b> ER2,ER1	4.3 <b>ADCX</b> IM,ER1							See 2nd Opcode Map
	2	2.2 <b>INC</b> R1	2.3 <b>INC</b> IR1	2.3 <b>SUB</b> r1,r2	2.4 <b>SUB</b> r1,lr2	3.3 <b>SUB</b> R2,R1	3.4 <b>SUB</b> IR2,R1	3.3 <b>SUB</b> R1,IM	3.4 <b>SUB</b> IR1,IM	4.3 <b>SUBX</b> ER2,ER1	4.3 <b>SUBX</b> IM,ER1							1, 2 ATM
	3	2.2 <b>DEC</b> R1	2.3 <b>DEC</b> IR1	2.3 <b>SBC</b> r1,r2	2.4 <b>SBC</b> r1,lr2	3.3 <b>SBC</b> R2,R1	3.4 <b>SBC</b> IR2,R1	3.3 <b>SBC</b> R1,IM	3.4 <b>SBC</b> IR1,IM	4.3 <b>SBCX</b> ER2,ER1	4.3 <b>SBCX</b> IM,ER1							
	4	2.2 <b>DA</b> R1	2.3 <b>DA</b> IR1	2.3 <b>OR</b> r1,r2	2.4 <b>OR</b> r1,lr2	3.3 <b>OR</b> R2,R1	3.4 <b>OR</b> IR2,R1	3.3 <b>OR</b> R1,IM	3.4 <b>OR</b> IR1,IM	4.3 <b>ORX</b> ER2,ER1	4.3 <b>ORX</b> IM,ER1							
	5	2.2 <b>POP</b> R1	2.3 <b>POP</b> IR1	2.3 <b>AND</b> r1,r2	2.4 <b>AND</b> r1,lr2	3.3 <b>AND</b> R2,R1	3.4 <b>AND</b> IR2,R1	3.3 <b>AND</b> R1,IM	3.4 <b>AND</b> IR1,IM	4.3 <b>ANDX</b> ER2,ER1	4.3 <b>ANDX</b> IM,ER1							1.2 WDT
	6	2.2 <b>COM</b> R1	2.3 <b>COM</b> IR1	2.3 <b>TCM</b> r1,r2	2.4 <b>TCM</b> r1,lr2	3.3 <b>TCM</b> R2,R1	3.4 <b>TCM</b> IR2,R1	3.3 <b>TCM</b> R1,IM	3.4 <b>TCM</b> IR1,IM	4.3 <b>TCMX</b> ER2,ER1	4.3 <b>TCMX</b> IM,ER1							1.2 STOP
	7	2.2 <b>PUSH</b> R2	2.3 <b>PUSH</b> IR2	2.3 <b>TM</b> r1,r2	2.4 <b>TM</b> r1,lr2	3.3 <b>TM</b> R2,R1	3.4 <b>TM</b> IR2,R1	3.3 <b>TM</b> R1,IM	3.4 <b>TM</b> IR1,IM	4.3 <b>TMX</b> ER2,ER1	4.3 <b>TMX</b> IM,ER1							1.2 HALT
	8	2.5 <b>DECW</b> RR1	2.6 <b>DECW</b> IRR1	2.5 <b>LDE</b> r1,lr2	2.9 <b>LDEI</b> lr1,lr2	3.2 <b>LDX</b> r1,ER2	3.3 <b>LDX</b> lr1,ER2	3.4 <b>LDX</b> IRR2,R1	3.5 <b>LDX</b> IRR2,IR1	3.4 <b>LDX</b> r1,rr2,X	3.4 <b>LDX</b> rr1,rr2,X							1.2 DI
	9	2.2 <b>RL</b> R1	2.3 <b>RL</b> IR1	2.5 <b>LDE</b> r2,lrr1	2.9 <b>LDEI</b> lr2,lrr1	3.2 <b>LDX</b> r2,ER1	3.3 <b>LDX</b> lr2,ER1	3.4 <b>LDX</b> R2,IRR1	3.5 <b>LDX</b> IR2,IRR1	3.3 <b>LEA</b> r1,r2,X	3.5 <b>LEA</b> rr1,rr2,X							1.2 EI
	A	2.5 <b>INCW</b> RR1	2.6 <b>INCW</b> IRR1	2.3 <b>CP</b> r1,r2	2.4 <b>CP</b> r1,lr2	3.3 <b>CP</b> R2,R1	3.4 <b>CP</b> IR2,R1	3.3 <b>CP</b> R1,IM	3.4 <b>CP</b> IR1,IM	4.3 <b>CPX</b> ER2,ER1	4.3 <b>CPX</b> IM,ER1							1.4 RET
	B	2.2 <b>CLR</b> R1	2.3 <b>CLR</b> IR1	2.3 <b>XOR</b> r1,r2	2.4 <b>XOR</b> r1,lr2	3.3 <b>XOR</b> R2,R1	3.4 <b>XOR</b> IR2,R1	3.3 <b>XOR</b> R1,IM	3.4 <b>XOR</b> IR1,IM	4.3 <b>XORX</b> ER2,ER1	4.3 <b>XORX</b> IM,ER1							1.5 IRET
	C	2.2 <b>RRC</b> R1	2.3 <b>RRC</b> IR1	2.5 <b>LDC</b> r1,lrr2	2.9 <b>LDCI</b> lr1,lrr2	2.3 <b>JP</b> IRR1	2.9 <b>LDC</b> lr1,lrr2		3.4 <b>LD</b> r1,r2,X	3.2 <b>PUSHX</b> ER2								1.2 RCF
	D	2.2 <b>SRA</b> R1	2.3 <b>SRA</b> IR1	2.5 <b>LDC</b> r2,lrr1	2.9 <b>LDCI</b> lr2,lrr1	2.6 <b>CALL</b> IRR1	2.2 <b>BSWAP</b> R1	3.3 <b>CALL</b> DA	3.4 <b>LD</b> r2,r1,X	3.2 <b>POPX</b> ER1								1.2 SCF
	E	2.2 <b>RR</b> R1	2.3 <b>RR</b> IR1	2.2 <b>BIT</b> p,b,r1	2.3 <b>LD</b> r1,lr2	3.2 <b>LD</b> R2,R1	3.3 <b>LD</b> IR2,R1	3.2 <b>LD</b> R1,IM	3.3 <b>LD</b> IR1,IM	4.2 <b>LDX</b> ER2,ER1	4.2 <b>LDX</b> IM,ER1							1.2 CCF
	F	2.2 <b>SWAP</b> R1	2.3 <b>SWAP</b> IR1	2.6 <b>TRAP</b> Vector	2.3 <b>LD</b> lr1,r2	2.8 <b>MULT</b> RR1	3.3 <b>LD</b> R2,IR1	3.3 <b>BTJ</b> p,b,r1,X	3.4 <b>BTJ</b> p,b,lrr1,X									

Figure 31. First Opcode Map

		Lower Nibble (Hex)															
		0	1	2	3	4	5	6	7	8	9	A	B	C	D	E	F
Upper Nibble (Hex)	0																
	1																
	2																
	3																
	4																
	5																
	6																
	7																
	8																
	9																
	A																
	B																
	C																
	D																
	E																
	F																

		Lower Nibble (Hex)															
		0	1	2	3	4	5	6	7	8	9	A	B	C	D	E	F
Upper Nibble (Hex)	0																
	1																
	2																
	3																
	4																
	5																
	6																
	7																
	8																
	9																
	A																
	B																
	C																
	D																
	E																
	F																

Figure 32. Second Opcode Map after 1FH



# Electrical Characteristics

The data in this chapter is pre-qualification and pre-characterization and is subject to change. Additional electrical characteristics may be found in the individual chapters.

## Absolute Maximum Ratings

Stresses greater than those listed in [Table 126](#) may cause permanent damage to the device. These ratings are stress ratings only. Operation of the device at any condition outside those indicated in the operational sections of these specifications is not implied. Exposure to absolute maximum rating conditions for extended periods may affect device reliability. For improved reliability, tie unused inputs to one of the supply voltages ( $V_{DD}$  or  $V_{SS}$ ).

**Table 126. Absolute Maximum Ratings**

Parameter	Minimum	Maximum	Units	Notes
Ambient temperature under bias	-40	+105	°C	
Storage temperature	-65	+150	°C	
Voltage on any pin with respect to $V_{SS}$	-0.3	+5.5	V	1
	-0.3	+3.9	V	2
Voltage on $V_{DD}$ pin with respect to $V_{SS}$	-0.3	+3.6	V	
Maximum current on input and/or inactive output pin	-5	+5	μA	
Maximum output current from active output pin	-25	+25	mA	
<b>8-pin Packages Maximum Ratings at 0 °C to 70 °C</b>				
Total power dissipation		220	mW	
Maximum current into $V_{DD}$ or out of $V_{SS}$		60	mA	
<b>20-pin Packages Maximum Ratings at 0 °C to 70 °C</b>				
Total power dissipation		430	mW	
Maximum current into $V_{DD}$ or out of $V_{SS}$		120	mA	



**Table 126. Absolute Maximum Ratings (Continued)**

Parameter	Minimum	Maximum	Units	Notes
<b>28-pin Packages Maximum Ratings at 0 °C to 70 °C</b>				
Total power dissipation		450	mW	
Maximum current into V <sub>DD</sub> or out of V <sub>SS</sub>		125	mA	
Operating temperature is specified in DC Characteristics.				
1. This voltage applies to all pins except the following: V <sub>DD</sub> , AV <sub>DD</sub> , pins supporting analog input (Port B[5:0], Port C[2:0]) and pins supporting the crystal oscillator (PA0 and PA1). On the 8-pin packages, this applies to all pins but V <sub>DD</sub> .				
2. This voltage applies to pins on the 20-/28-pin packages supporting analog input (Port B[5:0], Port C[2:0]) and pins supporting the crystal oscillator (PA0 and PA1).				

## DC Characteristics

Table 127 lists the DC characteristics of the Z8 Encore! XP<sup>®</sup> F082A Series products. All voltages are referenced to V<sub>SS</sub>, the primary system ground.

**Table 127. DC Characteristics**

Symbol	Parameter	T <sub>A</sub> = -40 °C to +105 °C (unless otherwise specified)			Units	Conditions
		Minimum	Typical	Maximum		
V <sub>DD</sub>	Supply Voltage	2.7	–	3.6	V	
V <sub>IL1</sub>	Low Level Input Voltage	-0.3	–	0.3*V <sub>DD</sub>	V	
V <sub>IH1</sub>	High Level Input Voltage	0.7*V <sub>DD</sub>	–	5.5	V	For all input pins without analog or oscillator function. For all signal pins on the 8-pin devices. Programmable pull-ups must also be disabled.
V <sub>IH2</sub>	High Level Input Voltage	0.7*V <sub>DD</sub>	–	V <sub>DD</sub> +0.3	V	For those pins with analog or oscillator function (20-/28-pin devices only), or when programmable pull-ups are enabled.
V <sub>OL1</sub>	Low Level Output Voltage	–	–	0.4	V	I <sub>OL</sub> = 2 mA; V <sub>DD</sub> = 3.0 V High Output Drive disabled.
V <sub>OH1</sub>	High Level Output Voltage	2.4	–	–	V	I <sub>OH</sub> = -2 mA; V <sub>DD</sub> = 3.0 V High Output Drive disabled.

**Table 127. DC Characteristics (Continued)**

		T <sub>A</sub> = -40 °C to +105 °C (unless otherwise specified)				
Symbol	Parameter	Minimum	Typical	Maximum	Units	Conditions
V <sub>OL2</sub>	Low Level Output Voltage	–	–	0.6	V	I <sub>OL</sub> = 20 mA; V <sub>DD</sub> = 3.3 V High Output Drive enabled.
V <sub>OH2</sub>	High Level Output Voltage	2.4	–	–	V	I <sub>OH</sub> = -20 mA; V <sub>DD</sub> = 3.3 V High Output Drive enabled.
I <sub>IH</sub>	Input Leakage Current	–	±0.002	±5	µA	V <sub>IN</sub> = V <sub>DD</sub> V <sub>DD</sub> = 3.3 V;
I <sub>IL</sub>	Input Leakage Current	–	±0.007	±5	µA	V <sub>IN</sub> = V <sub>SS</sub> V <sub>DD</sub> = 3.3 V;
I <sub>TL</sub>	Tristate Leakage Current	–	–	±5	µA	
I <sub>LED</sub>	Controlled Current Drive	1.8	3	4.5	mA	{AFS2,AFS1} = {0,0}
		2.8	7	10.5	mA	{AFS2,AFS1} = {0,1}
		7.8	13	19.5	mA	{AFS2,AFS1} = {1,0}
		12	20	30	mA	{AFS2,AFS1} = {1,1}
C <sub>PAD</sub>	GPIO Port Pad Capacitance	–	8.0 <sup>2</sup>	–	pF	
C <sub>XIN</sub>	XIN Pad Capacitance	–	8.0 <sup>2</sup>	–	pF	
C <sub>XOUT</sub>	XOUT Pad Capacitance	–	9.5 <sup>2</sup>	–	pF	
I <sub>PU</sub>	Weak Pull-up Current	30	100	350	µA	V <sub>DD</sub> = 3.0 V–3.6 V
V <sub>RAM</sub>	RAM Data Retention Voltage	TBD			V	Voltage at which RAM retains static values; no reading or writing is allowed.

**Notes**

1. This condition excludes all pins that have on-chip pull-ups, when driven Low.
2. These values are provided for design guidance only and are not tested in production.

**Table 128. Power Consumption**

Symbol	Parameter	V <sub>DD</sub> = 2.7 V to 3.6 V			Units	Conditions
		Typical <sup>1</sup>	Std Temp	Ext Temp		
I <sub>DD</sub> Stop	Supply Current in STOP Mode	0.1			μA	No peripherals enabled. All pins driven to V <sub>DD</sub> or V <sub>SS</sub> .
I <sub>DD</sub> Halt	Supply Current in HALT Mode (with all peripherals disabled)	35	55	65	μA	32 kHz
		520			μA	5.5 MHz
		2.1	2.85	2.85	mA	20 MHz
I <sub>DD</sub>	Supply Current in ACTIVE Mode (with all peripherals disabled)	2.8			mA	32 kHz
		4.5	5.2	5.2	mA	5.5 MHz
		5.5	6.5	6.5	mA	10 MHz
		7.9	11.5	11.5	mA	20 MHz
I <sub>DD</sub> WDT	Watchdog Timer Supply Current	0.9	1.0	1.1	μA	
I <sub>DD</sub> XTAL	Crystal Oscillator Supply Current	40			μA	32 kHz
		230			μA	4 MHz
		760			μA	20 MHz
I <sub>DD</sub> IPO	Internal Precision Oscillator Supply Current	350	500	550	μA	
I <sub>DD</sub> VBO	Voltage Brownout and Low-Voltage Detect Supply Current	50			μA	For 20-/28-pin devices (VBO only); See <a href="#">Notes 4</a> For 8-pin devices; See <a href="#">Notes 4</a>
I <sub>DD</sub> ADC	Analog to Digital Converter Supply Current (with External Reference)	2.8	3.1	3.2	mA	32 kHz
		3.1	3.6	3.7	mA	5.5 MHz
		3.3	3.7	3.8	mA	10 MHz
		3.7	4.2	4.3	mA	20 MHz
I <sub>DD</sub> ADCRef	ADC Internal Reference Supply Current	0			μA	See <a href="#">Notes 4</a>
I <sub>DD</sub> CMP	Comparator supply Current	150	180	190	μA	See <a href="#">Notes 4</a>

**Table 128. Power Consumption (Continued)**

		$V_{DD} = 2.7\text{ V to }3.6\text{ V}$				
		Maximum <sup>2</sup>		Maximum <sup>3</sup>		
Symbol	Parameter	Typical <sup>1</sup>	Std Temp	Ext Temp	Units	Conditions
$I_{DD}$ LPO	Low-Power Operational Amplifier Supply Current	3	5	5	$\mu\text{A}$	Driving a high-impedance load
$I_{DD}$ TS	Temperature Sensor Supply Current	60			$\mu\text{A}$	See <a href="#">Notes 4</a>
$I_{DD}$ BG	Band Gap Supply Current	320	480	500	$\mu\text{A}$	For 20-/28-pin devices For 8-pin devices

**Notes**

1. Typical conditions are defined as  $V_{DD} = 3.3\text{ V}$  and  $+30\text{ }^\circ\text{C}$ .
2. Standard temperature is defined as  $T_A = 0\text{ }^\circ\text{C}$  to  $+70\text{ }^\circ\text{C}$ ; these values not tested in production for worst case behavior, but are derived from product characterization and provided for design guidance only.
3. Extended temperature is defined as  $T_A = -40\text{ }^\circ\text{C}$  to  $+105\text{ }^\circ\text{C}$ ; these values not tested in production for worst case behavior, but are derived from product characterization and provided for design guidance only.
4. For this block to operate, the bandgap circuit is automatically turned on and must be added to the total supply current. This bandgap current is only added once, regardless of how many peripherals are using it.

Figure 33 displays the typical current consumption while operating with all peripherals disabled, at 30 °C, versus the system clock frequency.

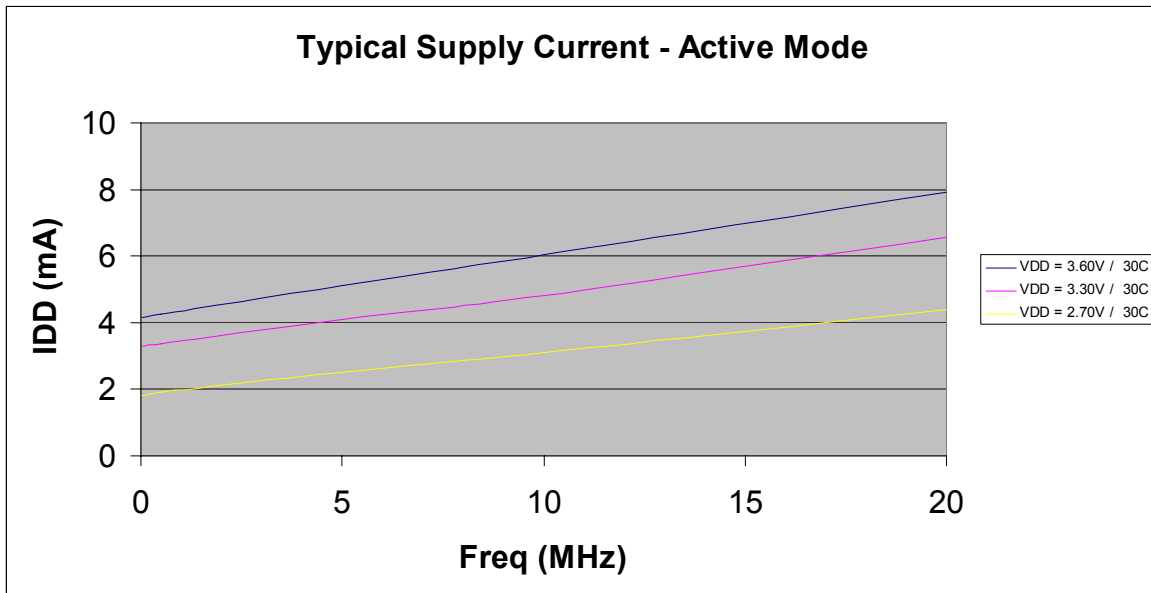

Figure 33. Typical Active Mode  $I_{DD}$  Versus System Clock Frequency

## AC Characteristics

The section provides information about the AC characteristics and timing. All AC timing information assumes a standard load of 50 pF on all outputs.

**Table 129. AC Characteristics**

		$V_{DD} = 2.7\text{ V to }3.6\text{ V}$ $T_A = -40\text{ °C to }+105\text{ °C}$ (unless otherwise stated)			
Symbol	Parameter	Minimum	Maximum	Units	Conditions
F <sub>SYSCLK</sub>	System Clock Frequency	–	20.0	MHz	Read-only from Flash memory
		0.032768	20.0	MHz	Program or erasure of the Flash memory
F <sub>XTAL</sub>	Crystal Oscillator Frequency	–	20.0	MHz	System clock frequencies below the crystal oscillator minimum require an external clock driver
T <sub>XIN</sub>	System Clock Period	50	–	ns	$T_{CLK} = 1/F_{sysclk}$
T <sub>XINH</sub>	System Clock High Time	20	30	ns	$T_{CLK} = 50\text{ ns}$
T <sub>XINL</sub>	System Clock Low Time	20	30	ns	$T_{CLK} = 50\text{ ns}$
T <sub>XINR</sub>	System Clock Rise Time	–	3	ns	$T_{CLK} = 50\text{ ns}$
T <sub>XINF</sub>	System Clock Fall Time	–	3	ns	$T_{CLK} = 50\text{ ns}$

**Table 130. Internal Precision Oscillator Electrical Characteristics**

		$V_{DD} = 2.7\text{ V to }3.6\text{ V}$ $T_A = -40\text{ °C to }+105\text{ °C}$ (unless otherwise stated)				
Symbol	Parameter	Minimum	Typical	Maximum	Units	Conditions
$F_{IPO}$	Internal Precision Oscillator Frequency (High Speed)		5.53		MHz	$V_{DD} = 3.3\text{ V}$ $T_A = 30\text{ °C}$
$F_{IPO}$	Internal Precision Oscillator Frequency (Low Speed)		32.7		kHz	$V_{DD} = 3.3\text{ V}$ $T_A = 30\text{ °C}$
$F_{IPO}$	Internal Precision Oscillator Error		$\pm 1$	$\pm 4$	%	
$T_{IPOST}$	Internal Precision Oscillator Startup Time		3		$\mu\text{s}$	

## On-Chip Peripheral AC and DC Electrical Characteristics

**Table 131. Power-On Reset and Voltage Brownout Electrical Characteristics and Timing**

Symbol	Parameter	T <sub>A</sub> = -40 °C to +105 °C			Units	Conditions
		Minimum	Typical <sup>1</sup>	Maximum		
V <sub>POR</sub>	Power-On Reset Voltage Threshold	2.20	2.45	2.70	V	V <sub>DD</sub> = V <sub>POR</sub>
V <sub>VBO</sub>	Voltage Brownout Reset Voltage Threshold	2.15	2.40	2.65	V	V <sub>DD</sub> = V <sub>VBO</sub>
	V <sub>POR</sub> to V <sub>VBO</sub> hysteresis		50	75	mV	
	Starting V <sub>DD</sub> voltage to ensure valid Power-On Reset.	–	V <sub>SS</sub>	–	V	
T <sub>ANA</sub>	Power-On Reset Analog Delay	–	70	–	μs	V <sub>DD</sub> > V <sub>POR</sub> ; T <sub>POR</sub> Digital Reset delay follows T <sub>ANA</sub>
T <sub>POR</sub>	Power-On Reset Digital Delay		16		μs	66 Internal Precision Oscillator cycles + IPO startup time (T <sub>IPOST</sub> )
T <sub>POR</sub>	Power-On Reset Digital Delay		1		ms	5000 Internal Precision Oscillator cycles
T <sub>SMR</sub>	Stop Mode Recovery with crystal oscillator disabled		16		μs	66 Internal Precision Oscillator cycles
T <sub>SMR</sub>	Stop Mode Recovery with crystal oscillator enabled		1		ms	5000 Internal Precision Oscillator cycles
T <sub>VBO</sub>	Voltage Brownout Pulse Rejection Period	–	10	–	μs	Period of time in which V <sub>DD</sub> < V <sub>VBO</sub> without generating a Reset.
T <sub>RAMP</sub>	Time for V <sub>DD</sub> to transition from V <sub>SS</sub> to V <sub>POR</sub> to ensure valid Reset	0.10	–	100	ms	
T <sub>SMP</sub>	Stop Mode Recovery pin pulse rejection period		20		ns	For any SMR pin or for the Reset pin when it is asserted in STOP mode.

<sup>1</sup>Data in the typical column is from characterization at 3.3 V and 30 °C. These values are provided for design guidance only and are not tested in production.



**Table 132. Flash Memory Electrical Characteristics and Timing**

$V_{DD} = 2.7\text{ V to }3.6\text{ V}$ $T_A = -40\text{ °C to }+105\text{ °C}$ (unless otherwise stated)					
Parameter	Minimum	Typical	Maximum	Units	Notes
Flash Byte Read Time	100	–	–	ns	
Flash Byte Program Time	20	–	40	μs	
Flash Page Erase Time	10	–	–	ms	
Flash Mass Erase Time	200	–	–	ms	
Writes to Single Address Before Next Erase	–	–	2		
Flash Row Program Time	–	–	8	ms	Cumulative program time for single row cannot exceed limit before next erase. This parameter is only an issue when bypassing the Flash Controller.
Data Retention	100	–	–	years	25 °C
Endurance	10,000	–	–	cycles	Program/erase cycles

**Table 133. Watchdog Timer Electrical Characteristics and Timing**

$V_{DD} = 2.7\text{ V to }3.6\text{ V}$ $T_A = -40\text{ °C to }+105\text{ °C}$ (unless otherwise stated)						
Symbol	Parameter	Minimum	Typical	Maximum	Units	Conditions
$F_{WDT}$	WDT Oscillator Frequency		10		kHz	
$F_{WDT}$	WDT Oscillator Error			±50	%	
$T_{WDTCAL}$	WDT Calibrated Timeout	0.98	1	1.02	s	$V_{DD} = 3.3\text{ V};$ $T_A = 30\text{ °C}$
		0.70	1	1.30	s	$V_{DD} = 2.7\text{ V to }3.6\text{ V}$ $T_A = 0\text{ °C to }70\text{ °C}$
		0.50	1	1.50	s	$V_{DD} = 2.7\text{ V to }3.6\text{ V}$ $T_A = -40\text{ °C to }+105\text{ °C}$

**Table 134. Non-Volatile Data Storage**

$V_{DD} = 2.7 \text{ V to } 3.6 \text{ V}$ $T_A = -40 \text{ }^\circ\text{C to } +105 \text{ }^\circ\text{C}$					
Parameter	Minimum	Typical	Maximum	Units	Notes
NVDS Byte Read Time	34	–	519	$\mu\text{s}$	With system clock at 20 MHz
NVDS Byte Program Time	0.171	–	39.7	ms	With system clock at 20 MHz
Data Retention	100	–	–	years	25 $^\circ\text{C}$
Endurance	160,000	–	–	cycles	Cumulative write cycles for entire memory

**Table 135. Analog-to-Digital Converter Electrical Characteristics and Timing**

$V_{DD} = 3.0 \text{ V to } 3.6 \text{ V}$ $T_A = 0 \text{ }^\circ\text{C to } +70 \text{ }^\circ\text{C}$ (unless otherwise stated)						
Symbol	Parameter	Minimum	Typical	Maximum	Units	Conditions
	Resolution	10	–	–	bits	
	Differential Nonlinearity (DNL)	-1.0	–	1.0	LSB <sup>3</sup>	External $V_{REF} = 2.0 \text{ V}$ ; $R_S \leftarrow 3.0 \text{ k}\Omega$
	Integral Nonlinearity (INL)	-3.0	–	3.0	LSB <sup>3</sup>	External $V_{REF} = 2.0 \text{ V}$ ; $R_S \leftarrow 3.0 \text{ k}\Omega$
	Offset Error with Calibration		$\pm 1$		LSB <sup>3</sup>	
	Absolute Accuracy with Calibration		$\pm 3$		LSB <sup>3</sup>	
$V_{REF}$	Internal Reference Voltage	1.0 2.0	1.1 2.2	1.2 2.4	V	REFSEL=01 REFSEL=10
$V_{REF}$	Internal Reference Variation with Temperature		$\pm 1.0$		%	Temperature variation with $V_{DD} = 3.0$
$V_{REF}$	Internal Reference Voltage Variation with $V_{DD}$		$\pm 0.5$		%	Supply voltage variation with $T_A = 30 \text{ }^\circ\text{C}$
$R_{REFOUT}$	Reference Buffer Output Impedance		850		$\Omega$	When the internal reference is buffered and driven out to the $V_{REF}$ pin (REFOUT = 1)

**Table 135. Analog-to-Digital Converter Electrical Characteristics and Timing (Continued)**

		$V_{DD} = 3.0\text{ V to }3.6\text{ V}$ $T_A = 0\text{ }^{\circ}\text{C to }+70\text{ }^{\circ}\text{C}$ (unless otherwise stated)				
Symbol	Parameter	Minimum	Typical	Maximum	Units	Conditions
	Single-Shot Conversion Time	–	5129	–	System clock cycles	All measurements but temperature sensor cycles
			10258			Temperature sensor measurement
	Continuous Conversion Time	–	256	–	System clock cycles	All measurements but temperature sensor cycles
			512			Temperature sensor measurement
	Signal Input Bandwidth	–	10		kHz	As defined by -3 dB point
$R_S$	Analog Source Impedance <sup>4</sup>	–	–	10	k $\Omega$	In unbuffered mode
				500	k $\Omega$	In buffered modes
$Z_{in}$	Input Impedance	–	150		k $\Omega$	In unbuffered mode at 20 MHz <sup>5</sup>
		10	–		M $\Omega$	In buffered modes
$V_{in}$	Input Voltage Range	0		$V_{DD}$	V	Unbuffered Mode
		0.3		$V_{DD}-1.1$	V	Buffered Modes

► **Note:** *These values define the range over which the ADC performs within spec; exceeding these values does not cause damage or instability; see [DC Characteristics](#) on page 222 for absolute pin voltage limits*

**Notes**

1. Analog source impedance affects the ADC offset voltage (because of pin leakage) and input settling time.
2. Devices are factory calibrated at  $V_{DD} = 3.3\text{ V}$  and  $T_A = +30\text{ }^{\circ}\text{C}$ , so the ADC is maximally accurate under these conditions.
3. LSBs are defined assuming 10-bit resolution.
4. This is the maximum recommended resistance seen by the ADC input pin.
5. The input impedance is inversely proportional to the system clock frequency.

**Table 136. Low Power Operational Amplifier Electrical Characteristics**

		$V_{DD} = 2.7\text{ V to }3.6\text{ V}$ $T_A = -40\text{ }^\circ\text{C to }+105\text{ }^\circ\text{C}$				
Symbol	Parameter	Minimum	Typical	Maximum	Units	Conditions
$A_v$	Open loop voltage gain		80		dB	
GBW	Gain/Bandwidth product		500		kHz	
PM	Phase Margin		50		deg	Assuming 13 pF load capacitance
$V_{osLPO}$	Input Offset Voltage		$\pm 1$	$\pm 4$	mV	
$V_{osLPO}$	Input Offset Voltage (Temperature Drift)		1	10	$\mu\text{V}/^\circ\text{C}$	
$V_{IN}$	Input Voltage Range	0.3		$V_{DD} - 1$	V	
$V_{OUT}$	Output Voltage Range	0.3		$V_{DD} - 1$	V	$I_{OUT} = 45\ \mu\text{A}$

**Table 137. Comparator Electrical Characteristics**

		$V_{DD} = 2.7\text{ V to }3.6\text{ V}$ $T_A = -40\text{ }^\circ\text{C to }+105\text{ }^\circ\text{C}$				
Symbol	Parameter	Minimum	Typical	Maximum	Units	Conditions
$V_{OS}$	Input DC Offset		5		mV	
$V_{CREF}$	Programmable Internal Reference Voltage		$\pm 5$		%	20-/28-pin devices
			$\pm 3$		%	8-pin devices
$T_{PROP}$	Propagation Delay		200		ns	
$V_{HYS}$	Input Hysteresis		4		mV	
$V_{IN}$	Input Voltage Range	$V_{SS}$		$V_{DD} - 1$	V	

**Table 138. Temperature Sensor Electrical Characteristics**

Symbol	Parameter	V <sub>DD</sub> = 2.7 V to 3.6 V			Units	Conditions
		Minimum	Typical	Maximum		
T <sub>AERR</sub>	Temperature Error		±0.5	±2	°C	Over the range +20 °C to +30 °C (as measured by ADC) <sup>1</sup>
			±1	±5	°C	Over the range +0 °C to +70 °C (as measured by ADC)
			±2	±7	°C	Over the range +0 °C to +105 °C (as measured by ADC)
			±7		°C	Over the range -40 °C to +105 °C (as measured by ADC)
T <sub>AERR</sub>	Temperature Error		TBD		°C	Over the range -40 °C to +105 °C (as measured by comparator)
t <sub>WAKE</sub>	Wakeup Time		80	100	μs	Time required for Temperature Sensor to stabilize after enabling

<sup>1</sup>Devices are factory calibrated at for maximal accuracy between +20 °C and +30 °C, so the sensor is maximally accurate in that range. User re-calibration for a different temperature range is possible and increases accuracy near the new calibration point.

## General Purpose I/O Port Input Data Sample Timing

Figure 34 displays timing of the GPIO Port input sampling. The input value on a GPIO Port pin is sampled on the rising edge of the system clock. The Port value is available to the eZ8 CPU on the second rising clock edge following the change of the Port value.

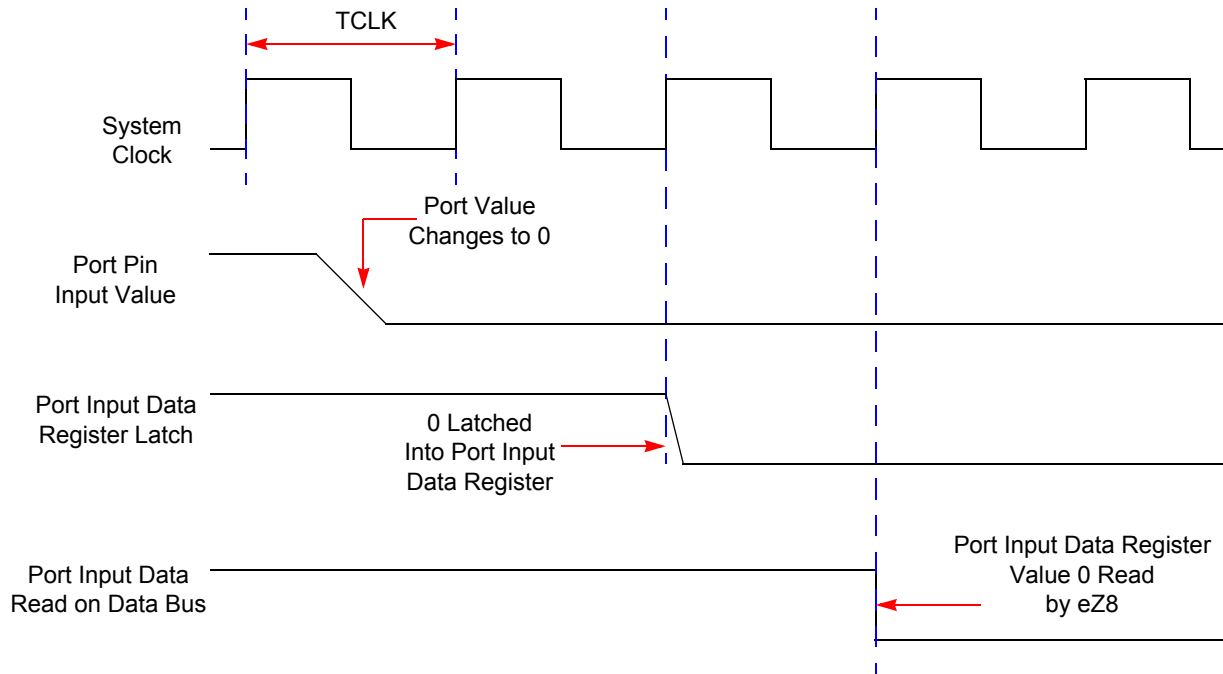

**Figure 34. Port Input Sample Timing**

**Table 139. GPIO Port Input Timing**

Parameter	Abbreviation	Delay (ns)	
		Minimum	Maximum
T <sub>S_PORT</sub>	Port Input Transition to XIN Rise Setup Time (Not pictured)	5	–
T <sub>H_PORT</sub>	XIN Rise to Port Input Transition Hold Time (Not pictured)	0	–
T <sub>SMR</sub>	GPIO Port Pin Pulse Width to ensure Stop Mode Recovery (for GPIO Port Pins enabled as SMR sources)	1 μs	

## General Purpose I/O Port Output Timing

Figure 35 and Table 140 provide timing information for GPIO Port pins.

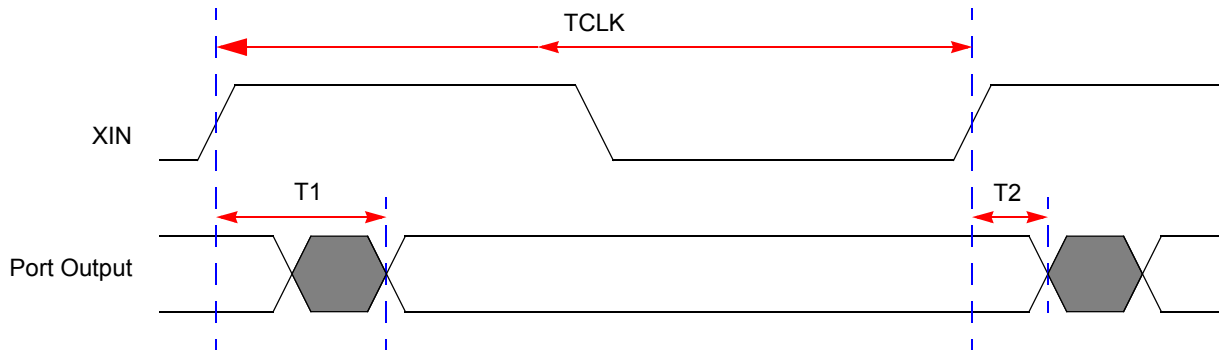

Figure 35. GPIO Port Output Timing

Table 140. GPIO Port Output Timing

Parameter	Abbreviation	Delay (ns)	
		Minimum	Maximum
<b>GPIO Port pins</b>			
T <sub>1</sub>	XIN Rise to Port Output Valid Delay	–	15
T <sub>2</sub>	XIN Rise to Port Output Hold Time	2	–

## On-Chip Debugger Timing

Figure 36 and Table 141 provide timing information for the DBG pin. The DBG pin timing specifications assume a 4 ns maximum rise and fall time.

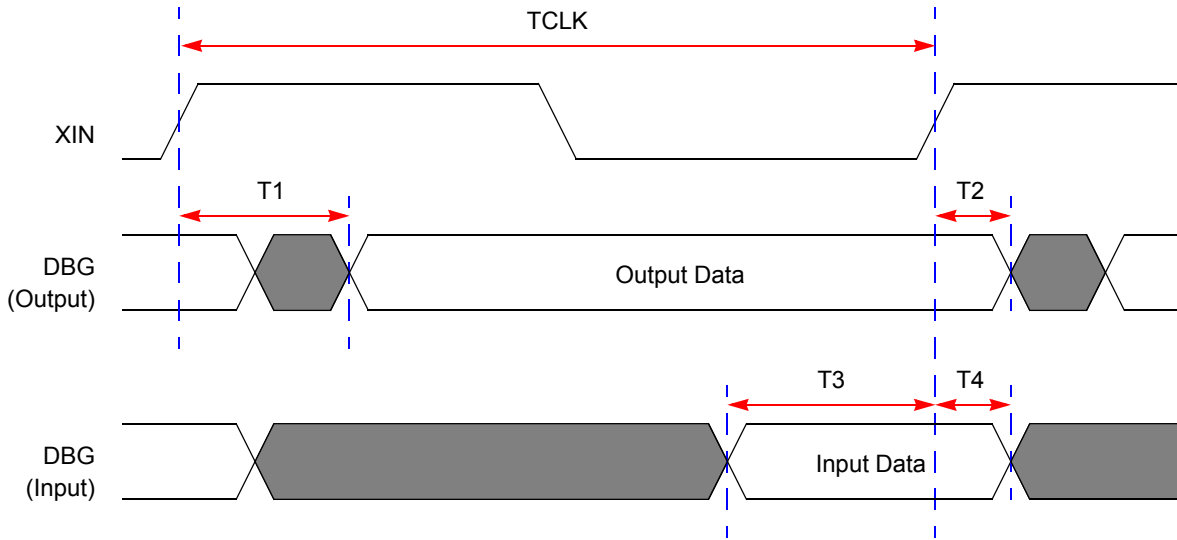

Figure 36. On-Chip Debugger Timing

Table 141. On-Chip Debugger Timing

Parameter	Abbreviation	Delay (ns)	
		Minimum	Maximum
<b>DBG</b>			
T <sub>1</sub>	XIN Rise to DBG Valid Delay	–	15
T <sub>2</sub>	XIN Rise to DBG Output Hold Time	2	–
T <sub>3</sub>	DBG to XIN Rise Input Setup Time	5	–
T <sub>4</sub>	DBG to XIN Rise Input Hold Time	5	–



## UART Timing

Figure 37 and Table 142 provide timing information for UART pins for the case where CTS is used for flow control. The CTS to DE assertion delay (T1) assumes the transmit data register has been loaded with data prior to CTS assertion.

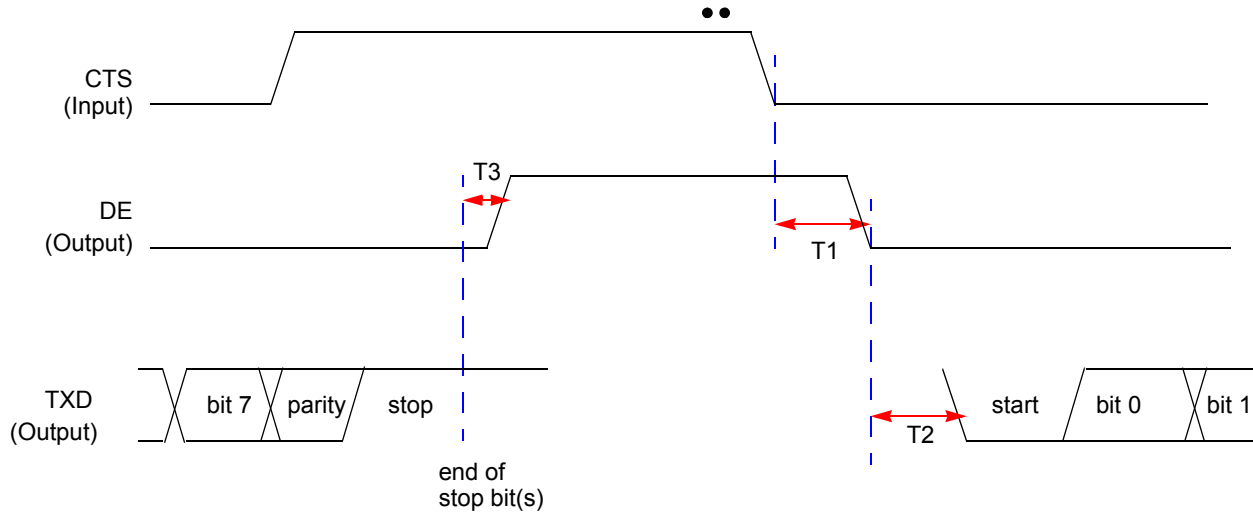

Figure 37. UART Timing With CTS

Table 142. UART Timing With CTS

Parameter	Abbreviation	Delay (ns)	
		Minimum	Maximum
<b>UART</b>			
T <sub>1</sub>	CTS Fall to DE output delay	2 * XIN period	2 * XIN period + 1 bit time
T <sub>2</sub>	DE assertion to TXD falling edge (start bit) delay ± 5		
T <sub>3</sub>	End of Stop Bit(s) to DE deassertion delay	± 5	

Figure 38 and Table 143 provide timing information for UART pins for the case where CTS is not used for flow control. DE asserts after the transmit data register has been written. DE remains asserted for multiple characters as long as the transmit data register is written with the next character before the current character has completed.

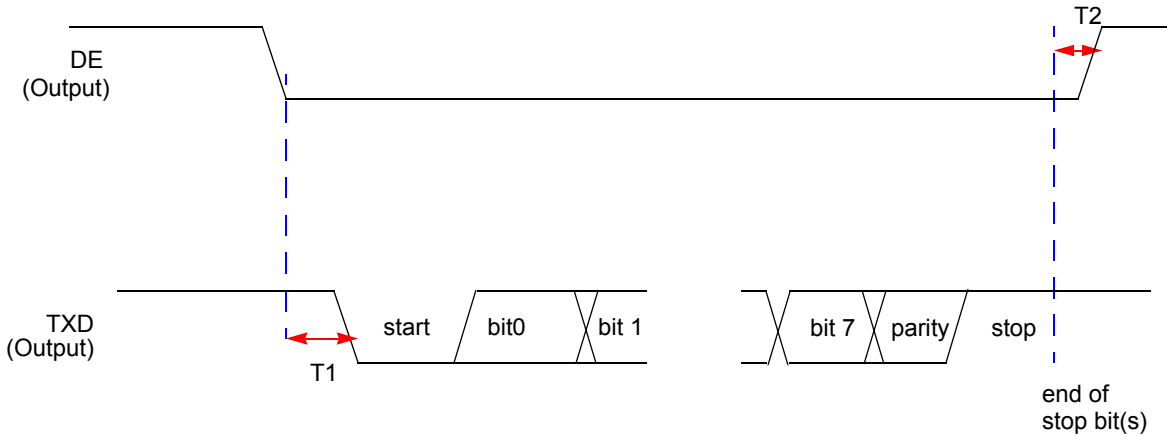

Figure 38. UART Timing Without CTS

Table 143. UART Timing Without CTS

Parameter	Abbreviation	Delay (ns)	
		Minimum	Maximum
<b>UART</b>			
T <sub>1</sub>	DE assertion to TXD falling edge (start bit) delay	1 * XIN period	1 bit time
T <sub>2</sub>	End of Stop Bit(s) to DE deassertion delay (Tx data register is empty)	± 5	



# Packaging

Figure 39 displays the 8-pin Plastic Dual Inline Package (PDIP) available for Z8 Encore! XP<sup>®</sup> F082A Series devices.

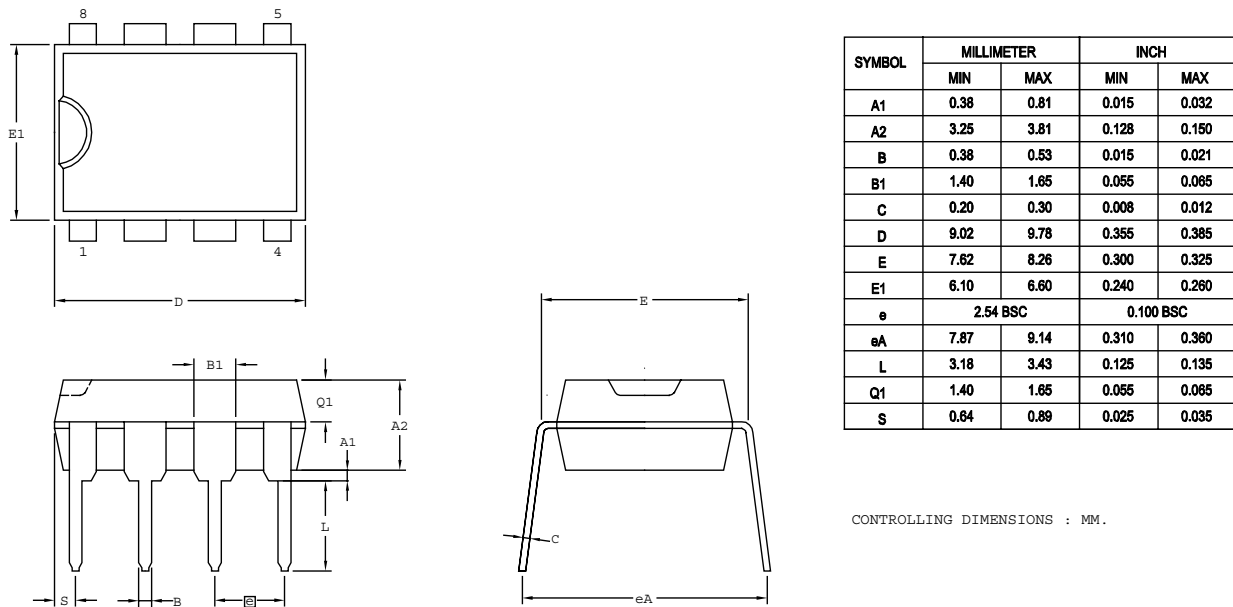

CONTROLLING DIMENSIONS : MM.

Figure 39. 8-Pin Plastic Dual Inline Package (PDIP)

Figure 40 displays the 8-pin Small Outline Integrated Circuit package (SOIC) available for the Z8 Encore! XP<sup>®</sup> F082A Series devices.

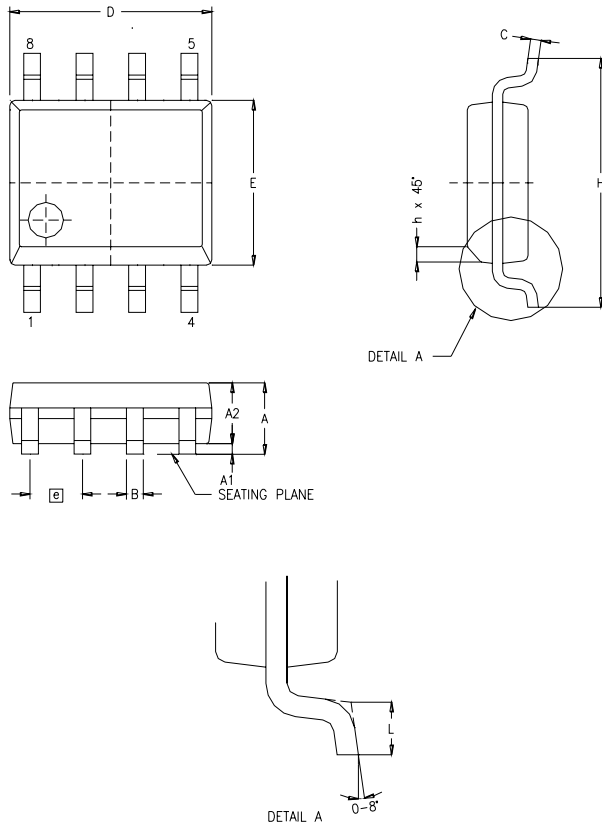

SYMBOL	MILLIMETER		INCH	
	MIN	MAX	MIN	MAX
A	1.55	1.73	0.061	0.068
A1	0.10	0.25	0.004	0.010
A2	1.40	1.55	0.055	0.061
B	0.36	0.48	0.014	0.019
C	0.18	0.25	0.007	0.010
D	4.80	4.98	0.189	0.196
E	3.81	3.99	0.150	0.157
ⓐ	1.27 BSC		.050 BSC	
H	5.84	6.15	0.230	0.242
h	0.25	0.40	0.010	0.016
L	0.46	0.81	0.018	0.032

CONTROLLING DIMENSIONS : MM  
LEADS ARE COPLANAR WITHIN .004 INCH.

Figure 40. 8-Pin Small Outline Integrated Circuit Package (SOIC)

Figure 41 displays the 8-pin Quad Flat No-Lead package (QFN)/MLF-S available for the Z8 Encore! XP F082A Series devices. This package has a footprint identical to that of the 8-pin SOIC, but with a lower profile.

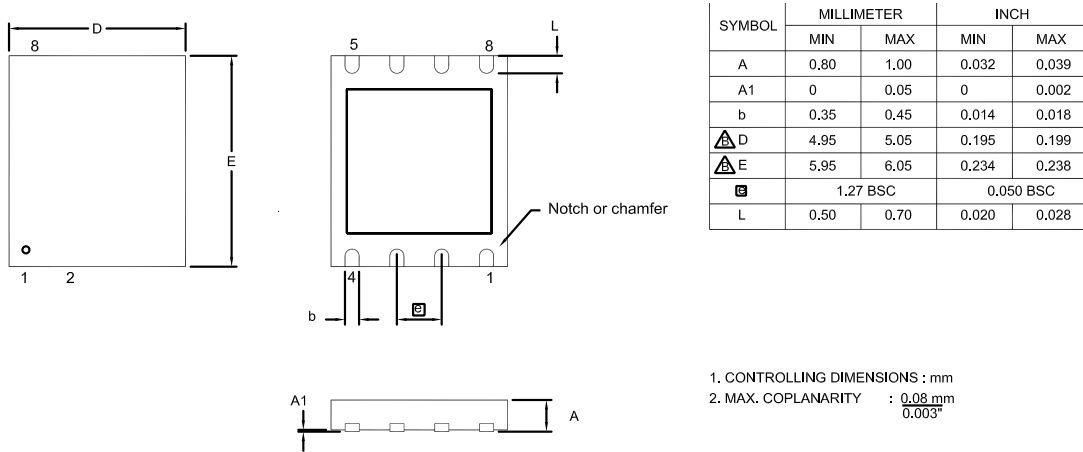

Figure 41. 8-Pin Quad Flat No-Lead Package (QFN)/MLF-S

Figure 42 displays the 20-pin Plastic Dual Inline Package (PDIP) available for the Z8 Encore! XP F082A Series devices.

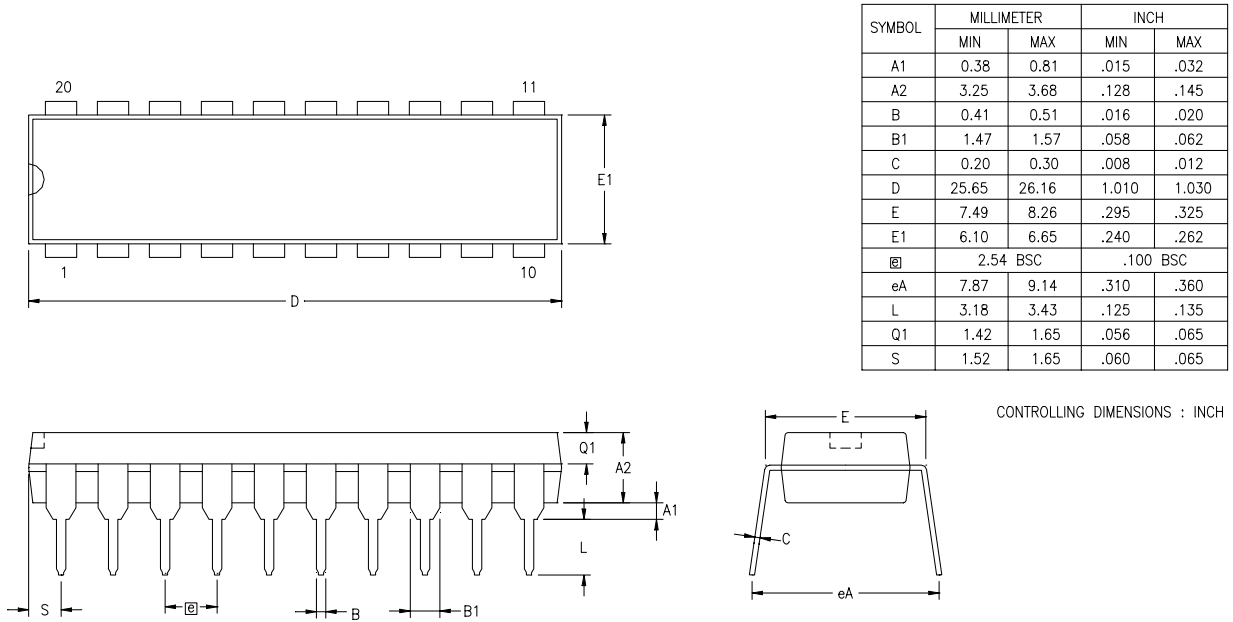

Figure 42. 20-Pin Plastic Dual Inline Package (PDIP)

Figure 43 displays the 20-pin Small Outline Integrated Circuit Package (SOIC) available for the Z8 Encore! XP F082A Series devices.

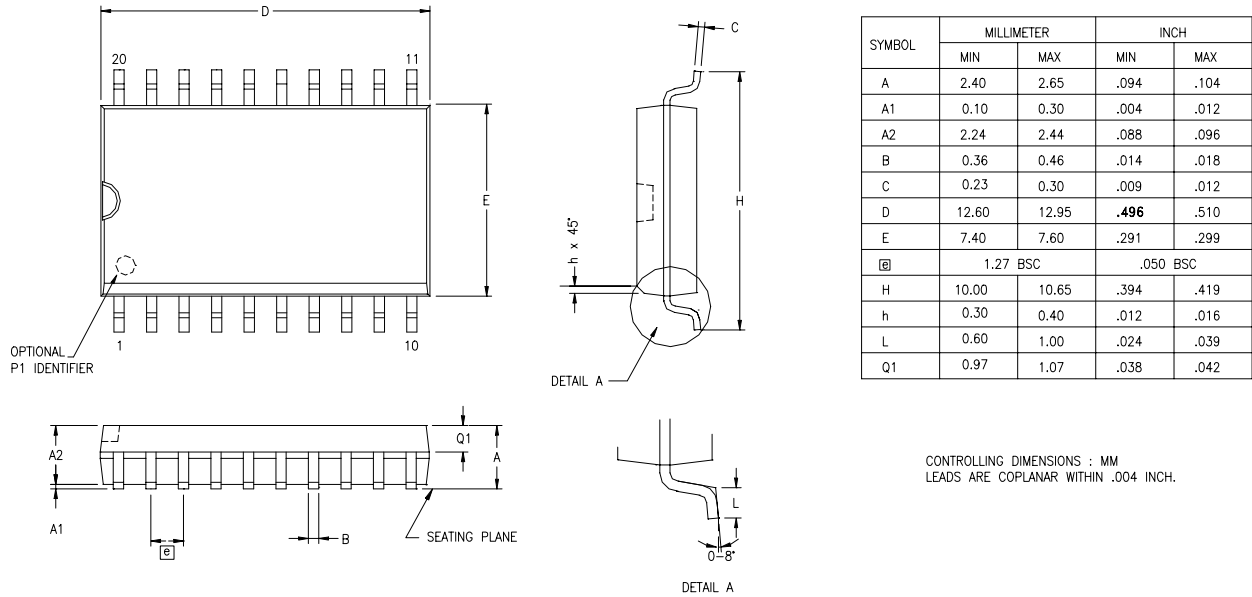

Figure 43. 20-Pin Small Outline Integrated Circuit Package (SOIC)



Figure 44 displays the 20-pin Small Shrink Outline Package (SSOP) available for the Z8 Encore! XP F082A Series devices.

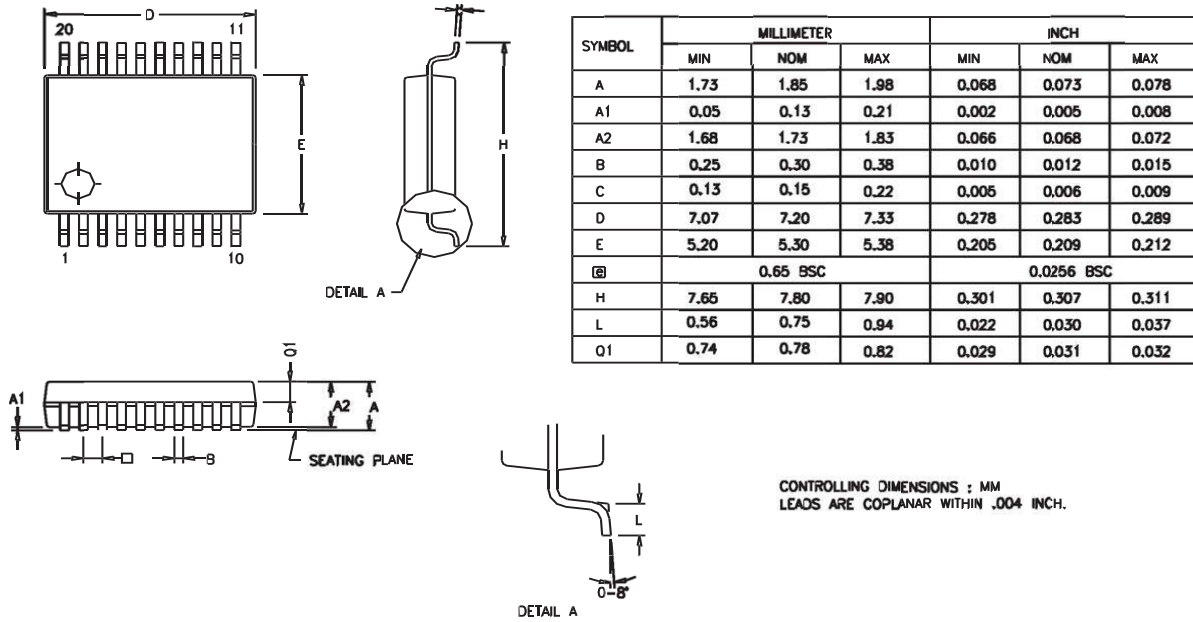
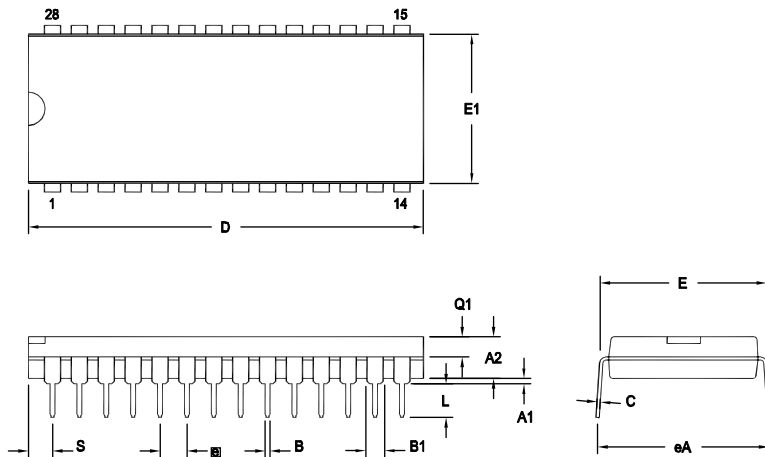

Figure 44. 20-Pin Small Shrink Outline Package (SSOP)

Figure 45 displays the 28-pin Plastic Dual Inline Package (PDIP) available for the Z8 Encore! XP F082A Series devices.



SYMBOL	OPT #	MILLIMETER		INCH	
		MIN	MAX	MIN	MAX
A1		0.38	1.02	.015	.040
A2		3.18	4.19	.125	.165
B		0.38	0.53	.015	.021
B1	01	1.40	1.65	.055	.065
	02	1.14	1.40	.045	.055
C		0.23	0.38	.009	.015
D	01	36.58	37.34	1.440	1.470
	02	35.31	35.94	1.390	1.415
E		15.24	15.75	.600	.620
E1	01	13.59	14.10	.535	.555
	02	12.83	13.08	.505	.515
e		2.54 TYP		.100 BSC	
eA		15.49	16.76	.610	.660
L		3.05	3.81	.120	.150
Q1	01	1.40	1.91	.055	.075
	02	1.40	1.78	.055	.070
S	01	1.52	2.29	.060	.090
	02	1.02	1.52	.040	.060

CONTROLLING DIMENSIONS : INCH

OPTION TABLE	
OPTION #	PACKAGE
01	STANDARD
02	IDF

Note: ZILOG supplies both options for production. Component layout PCB design should cover bigger option 01.

Figure 45. 28-Pin Plastic Dual Inline Package (PDIP)

Figure 46 displays the 28-pin Small Outline Integrated Circuit package (SOIC) available in the Z8 Encore! XP F082A Series devices.

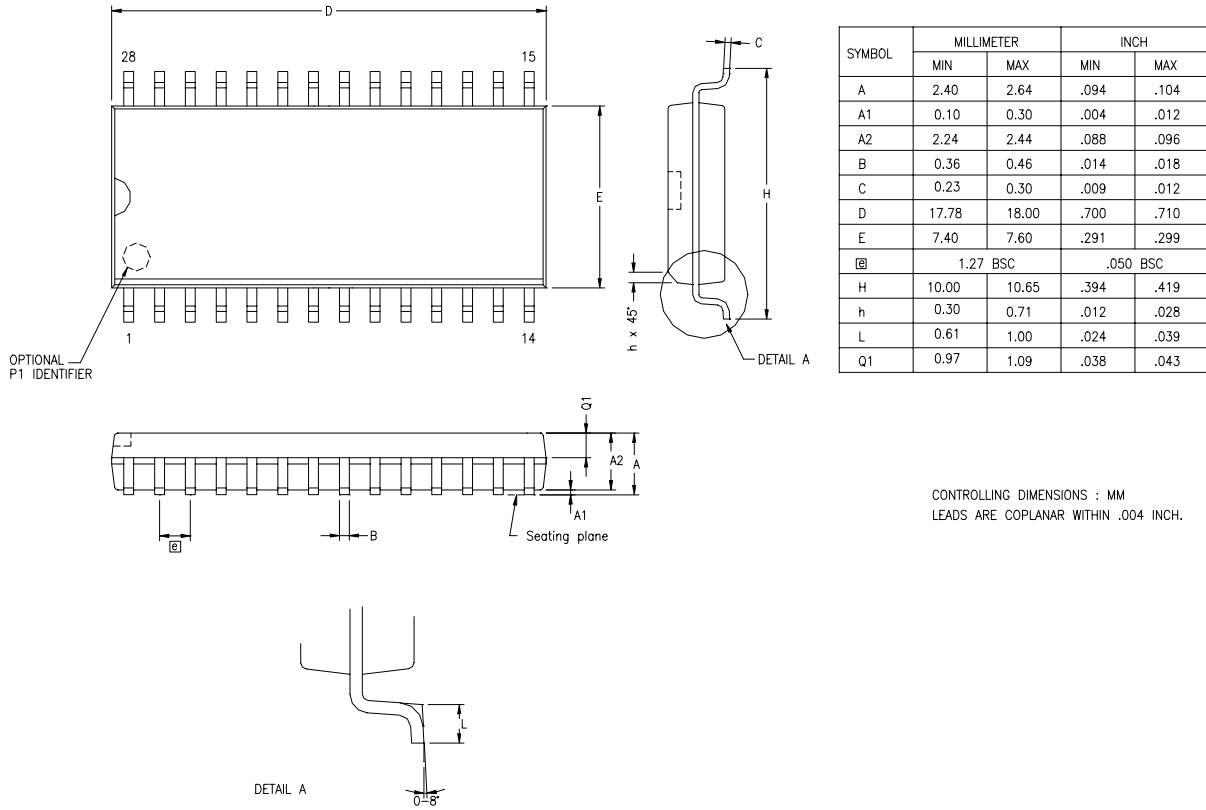

Figure 46. 28-Pin Small Outline Integrated Circuit Package (SOIC)

Figure 47 displays the 28-pin Small Shrink Outline Package (SSOP) available for the Z8 Encore! XP F082A Series devices.

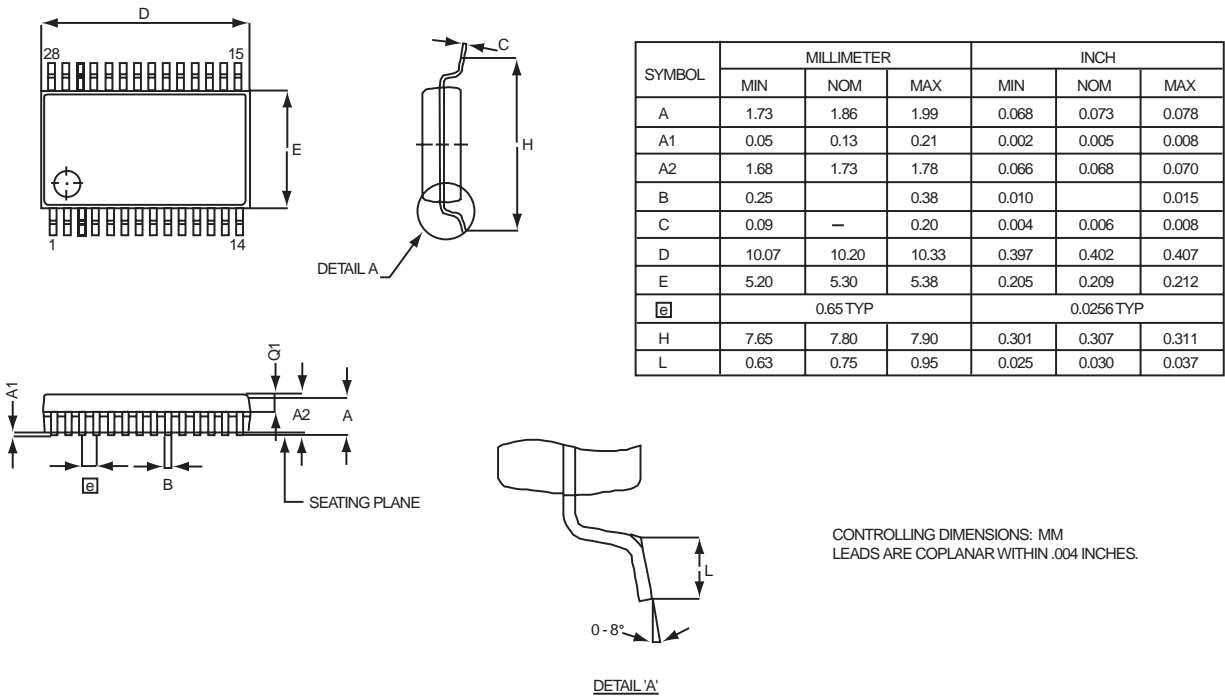

Figure 47. 28-Pin Small Shrink Outline Package (SSOP)





## Ordering Information

Order the Z8 Encore! XP<sup>®</sup> F082A Series from Zilog<sup>®</sup>, using the following part numbers. For more information on ordering, please consult your local Zilog sales office. The Zilog website ([www.zilog.com](http://www.zilog.com)) lists all regional offices and provides additional Z8 Encore! XP product information.

Part Number	Flash	RAM	NVDS	I/O Lines	Interrupts	16-Bit Timers w/PWM	10-Bit A/D Channels	UART with IrDA	Comparator	Temperature Sensor	Description
<b>Z8 Encore! XP<sup>®</sup> F082A Series with 8 KB Flash, 10-Bit Analog-to-Digital Converter</b>											
<b>Standard Temperature: 0 °C to 70 °C</b>											
Z8F082APB020SC	8 KB	1 KB	0	6	14	2	4	1	1	1	PDIP 8-pin package
Z8F082AQB020SC	8 KB	1 KB	0	6	14	2	4	1	1	1	QFN 8-pin package
Z8F082ASB020SC	8 KB	1 KB	0	6	14	2	4	1	1	1	SOIC 8-pin package
Z8F082ASH020SC	8 KB	1 KB	0	17	20	2	7	1	1	1	SOIC 20-pin package
Z8F082AHH020SC	8 KB	1 KB	0	17	20	2	7	1	1	1	SSOP 20-pin package
Z8F082APH020SC	8 KB	1 KB	0	17	20	2	7	1	1	1	PDIP 20-pin package
Z8F082ASJ020SC	8 KB	1 KB	0	23	20	2	8	1	1	1	SOIC 28-pin package
Z8F082AHJ020SC	8 KB	1 KB	0	23	20	2	8	1	1	1	SSOP 28-pin package
Z8F082APJ020SC	8 KB	1 KB	0	23	20	2	8	1	1	1	PDIP 28-pin package
<b>Extended Temperature: -40 °C to 105 °C</b>											
Z8F082APB020EC	8 KB	1 KB	0	6	14	2	4	1	1	1	PDIP 8-pin package
Z8F082AQB020EC	8 KB	1 KB	0	6	14	2	4	1	1	1	QFN 8-pin package
Z8F082ASB020EC	8 KB	1 KB	0	6	14	2	4	1	1	1	SOIC 8-pin package
Z8F082ASH020EC	8 KB	1 KB	0	17	20	2	7	1	1	1	SOIC 20-pin package
Z8F082AHH020EC	8 KB	1 KB	0	17	20	2	7	1	1	1	SSOP 20-pin package
Z8F082APH020EC	8 KB	1 KB	0	17	20	2	7	1	1	1	PDIP 20-pin package
Z8F082ASJ020EC	8 KB	1 KB	0	23	20	2	8	1	1	1	SOIC 28-pin package
Z8F082AHJ020EC	8 KB	1 KB	0	23	20	2	8	1	1	1	SSOP 28-pin package
Z8F082APJ020EC	8 KB	1 KB	0	23	20	2	8	1	1	1	PDIP 28-pin package
Replace C with G for Lead-Free Packaging											



Part Number	Flash	RAM	NVDS	I/O Lines	Interrupts	16-Bit Timers w/PWM	10-Bit A/D Channels	UART with IrDA	Comparator	Temperature Sensor	Description
<b>Z8 Encore! XP<sup>®</sup> F082A Series with 8 KB Flash</b>											
<b>Standard Temperature: 0 °C to 70 °C</b>											
Z8F081APB020SC	8 KB	1 KB	0	6	13	2	0	1	1	0	PDIP 8-pin package
Z8F081AQB020SC	8 KB	1 KB	0	6	13	2	0	1	1	0	QFN 8-pin package
Z8F081ASB020SC	8 KB	1 KB	0	6	13	2	0	1	1	0	SOIC 8-pin package
Z8F081ASH020SC	8 KB	1 KB	0	17	19	2	0	1	1	0	SOIC 20-pin package
Z8F081AHH020SC	8 KB	1 KB	0	17	19	2	0	1	1	0	SSOP 20-pin package
Z8F081APH020SC	8 KB	1 KB	0	17	19	2	0	1	1	0	PDIP 20-pin package
Z8F081ASJ020SC	8 KB	1 KB	0	25	19	2	0	1	1	0	SOIC 28-pin package
Z8F081AHJ020SC	8 KB	1 KB	0	25	19	2	0	1	1	0	SSOP 28-pin package
Z8F081APJ020SC	8 KB	1 KB	0	25	19	2	0	1	1	0	PDIP 28-pin package
<b>Extended Temperature: -40 °C to 105 °C</b>											
Z8F081APB020EC	8 KB	1 KB	0	6	13	2	0	1	1	0	PDIP 8-pin package
Z8F081AQB020EC	8 KB	1 KB	0	6	13	2	0	1	1	0	QFN 8-pin package
Z8F081ASB020EC	8 KB	1 KB	0	6	13	2	0	1	1	0	SOIC 8-pin package
Z8F081ASH020EC	8 KB	1 KB	0	17	19	2	0	1	1	0	SOIC 20-pin package
Z8F081AHH020EC	8 KB	1 KB	0	17	19	2	0	1	1	0	SSOP 20-pin package
Z8F081APH020EC	8 KB	1 KB	0	17	19	2	0	1	1	0	PDIP 20-pin package
Z8F081ASJ020EC	8 KB	1 KB	0	25	19	2	0	1	1	0	SOIC 28-pin package
Z8F081AHJ020EC	8 KB	1 KB	0	25	19	2	0	1	1	0	SSOP 28-pin package
Z8F081APJ020EC	8 KB	1 KB	0	25	19	2	0	1	1	0	PDIP 28-pin package
Replace C with G for Lead-Free Packaging											



Part Number	Flash	RAM	NVDS	I/O Lines	Interrupts	16-Bit Timers w/PWM	10-Bit A/D Channels	UART with IrDA	Comparator	Temperature Sensor	Description
<b>Z8 Encore! XP<sup>®</sup> F082A Series with 4 KB Flash, 10-Bit Analog-to-Digital Converter</b>											
<b>Standard Temperature: 0 °C to 70 °C</b>											
Z8F042APB020SC	4 KB	1 KB	128 B	6	14	2	4	1	1	1	PDIP 8-pin package
Z8F042AQB020SC	4 KB	1 KB	128 B	6	14	2	4	1	1	1	QFN 8-pin package
Z8F042ASB020SC	4 KB	1 KB	128 B	6	14	2	4	1	1	1	SOIC 8-pin package
Z8F042ASH020SC	4 KB	1 KB	128 B	17	20	2	7	1	1	1	SOIC 20-pin package
Z8F042AHH020SC	4 KB	1 KB	128 B	17	20	2	7	1	1	1	SSOP 20-pin package
Z8F042APH020SC	4 KB	1 KB	128 B	17	20	2	7	1	1	1	PDIP 20-pin package
Z8F042ASJ020SC	4 KB	1 KB	128 B	23	20	2	8	1	1	1	SOIC 28-pin package
Z8F042AHJ020SC	4 KB	1 KB	128 B	23	20	2	8	1	1	1	SSOP 28-pin package
Z8F042APJ020SC	4 KB	1 KB	128 B	23	20	2	8	1	1	1	PDIP 28-pin package
<b>Extended Temperature: -40 °C to 105 °C</b>											
Z8F042APB020EC	4 KB	1 KB	128 B	6	14	2	4	1	1	1	PDIP 8-pin package
Z8F042AQB020EC	4 KB	1 KB	128 B	6	14	2	4	1	1	1	QFN 8-pin package
Z8F042ASB020EC	4 KB	1 KB	128 B	6	14	2	4	1	1	1	SOIC 8-pin package
Z8F042ASH020EC	4 KB	1 KB	128 B	17	20	2	7	1	1	1	SOIC 20-pin package
Z8F042AHH020EC	4 KB	1 KB	128 B	17	20	2	7	1	1	1	SSOP 20-pin package
Z8F042APH020EC	4 KB	1 KB	128 B	17	20	2	7	1	1	1	PDIP 20-pin package
Z8F042ASJ020EC	4 KB	1 KB	128 B	23	20	2	8	1	1	1	SOIC 28-pin package
Z8F042AHJ020EC	4 KB	1 KB	128 B	23	20	2	8	1	1	1	SSOP 28-pin package
Z8F042APJ020EC	4 KB	1 KB	128 B	23	20	2	8	1	1	1	PDIP 28-pin package
Replace C with G for Lead-Free Packaging											





Part Number	Flash	RAM	NVDS	I/O Lines	Interrupts	16-Bit Timers w/PWM	10-Bit A/D Channels	UART with IrDA	Comparator	Temperature Sensor	Description
<b>Z8 Encore! XP<sup>®</sup> F082A Series with 4 KB Flash</b>											
<b>Standard Temperature: 0 °C to 70 °C</b>											
Z8F041APB020SC	4 KB	1 KB	128 B	6	13	2	0	1	1	0	PDIP 8-pin package
Z8F041AQB020SC	4 KB	1 KB	128 B	6	13	2	0	1	1	0	QFN 8-pin package
Z8F041ASB020SC	4 KB	1 KB	128 B	6	13	2	0	1	1	0	SOIC 8-pin package
Z8F041ASH020SC	4 KB	1 KB	128 B	17	19	2	0	1	1	0	SOIC 20-pin package
Z8F041AHH020SC	4 KB	1 KB	128 B	17	19	2	0	1	1	0	SSOP 20-pin package
Z8F041APH020SC	4 KB	1 KB	128 B	17	19	2	0	1	1	0	PDIP 20-pin package
Z8F041ASJ020SC	4 KB	1 KB	128 B	25	19	2	0	1	1	0	SOIC 28-pin package
Z8F041AHJ020SC	4 KB	1 KB	128 B	25	19	2	0	1	1	0	SSOP 28-pin package
Z8F041APJ020SC	4 KB	1 KB	128 B	25	19	2	0	1	1	0	PDIP 28-pin package
<b>Extended Temperature: -40 °C to 105 °C</b>											
Z8F041APB020EC	4 KB	1 KB	128 B	6	13	2	0	1	1	0	PDIP 8-pin package
Z8F041AQB020EC	4 KB	1 KB	128 B	6	13	2	0	1	1	0	QFN 8-pin package
Z8F041ASB020EC	4 KB	1 KB	128 B	6	13	2	0	1	1	0	SOIC 8-pin package
Z8F041ASH020EC	4 KB	1 KB	128 B	17	19	2	0	1	1	0	SOIC 20-pin package
Z8F041AHH020EC	4 KB	1 KB	128 B	17	19	2	0	1	1	0	SSOP 20-pin package
Z8F041APH020EC	4 KB	1 KB	128 B	17	19	2	0	1	1	0	PDIP 20-pin package
Z8F041ASJ020EC	4 KB	1 KB	128 B	25	19	2	0	1	1	0	SOIC 28-pin package
Z8F041AHJ020EC	4 KB	1 KB	128 B	25	19	2	0	1	1	0	SSOP 28-pin package
Z8F041APJ020EC	4 KB	1 KB	128 B	25	19	2	0	1	1	0	PDIP 28-pin package
Replace C with G for Lead-Free Packaging											



Part Number	Flash	RAM	NVDS	I/O Lines	Interrupts	16-Bit Timers w/PWM	10-Bit A/D Channels	UART with IrDA	Comparator	Temperature Sensor	Description
<b>Z8 Encore! XP<sup>®</sup> F082A Series with 2 KB Flash, 10-Bit Analog-to-Digital Converter</b>											
<b>Standard Temperature: 0 °C to 70 °C</b>											
Z8F022APB020SC	2 KB	512 B	64 B	6	14	2	4	1	1	1	PDIP 8-pin package
Z8F022AQB020SC	2 KB	512 B	64 B	6	14	2	4	1	1	1	QFN 8-pin package
Z8F022ASB020SC	2 KB	512 B	64 B	6	14	2	4	1	1	1	SOIC 8-pin package
Z8F022ASH020SC	2 KB	512 B	64 B	17	20	2	7	1	1	1	SOIC 20-pin package
Z8F022AHH020SC	2 KB	512 B	64 B	17	20	2	7	1	1	1	SSOP 20-pin package
Z8F022APH020SC	2 KB	512 B	64 B	17	20	2	7	1	1	1	PDIP 20-pin package
Z8F022ASJ020SC	2 KB	512 B	64 B	23	20	2	8	1	1	1	SOIC 28-pin package
Z8F022AHJ020SC	2 KB	512 B	64 B	23	20	2	8	1	1	1	SSOP 28-pin package
Z8F022APJ020SC	2 KB	512 B	64 B	23	20	2	8	1	1	1	PDIP 28-pin package
<b>Extended Temperature: -40 °C to 105 °C</b>											
Z8F022APB020EC	2 KB	512 B	64 B	6	14	2	4	1	1	1	PDIP 8-pin package
Z8F022AQB020EC	2 KB	512 B	64 B	6	14	2	4	1	1	1	QFN 8-pin package
Z8F022ASB020EC	2 KB	512 B	64 B	6	14	2	4	1	1	1	SOIC 8-pin package
Z8F022ASH020EC	2 KB	512 B	64 B	17	20	2	7	1	1	1	SOIC 20-pin package
Z8F022AHH020EC	2 KB	512 B	64 B	17	20	2	7	1	1	1	SSOP 20-pin package
Z8F022APH020EC	2 KB	512 B	64 B	17	20	2	7	1	1	1	PDIP 20-pin package
Z8F022ASJ020EC	2 KB	512 B	64 B	23	20	2	8	1	1	1	SOIC 28-pin package
Z8F022AHJ020EC	2 KB	512 B	64 B	23	20	2	8	1	1	1	SSOP 28-pin package
Z8F022APJ020EC	2 KB	512 B	64 B	23	20	2	8	1	1	1	PDIP 28-pin package
Replace C with G for Lead-Free Packaging											



Part Number	Flash	RAM	NVDS	I/O Lines	Interrupts	16-Bit Timers w/PWM	10-Bit A/D Channels	UART with IrDA	Comparator	Temperature Sensor	Description
<b>Z8 Encore! XP<sup>®</sup> F082A Series with 2 KB Flash</b>											
<b>Standard Temperature: 0 °C to 70 °C</b>											
Z8F021APB020SC	2 KB	512 B	64 B	6	13	2	0	1	1	0	PDIP 8-pin package
Z8F021AQB020SC	2 KB	512 B	64 B	6	13	2	0	1	1	0	QFN 8-pin package
Z8F021ASB020SC	2 KB	512 B	64 B	6	13	2	0	1	1	0	SOIC 8-pin package
Z8F021ASH020SC	2 KB	512 B	64 B	17	19	2	0	1	1	0	SOIC 20-pin package
Z8F021AHH020SC	2 KB	512 B	64 B	17	19	2	0	1	1	0	SSOP 20-pin package
Z8F021APH020SC	2 KB	512 B	64 B	17	19	2	0	1	1	0	PDIP 20-pin package
Z8F021ASJ020SC	2 KB	512 B	64 B	25	19	2	0	1	1	0	SOIC 28-pin package
Z8F021AHJ020SC	2 KB	512 B	64 B	25	19	2	0	1	1	0	SSOP 28-pin package
Z8F021APJ020SC	2 KB	512 B	64 B	25	19	2	0	1	1	0	PDIP 28-pin package
<b>Extended Temperature: -40 °C to 105 °C</b>											
Z8F021APB020EC	2 KB	512 B	64 B	6	13	2	0	1	1	0	PDIP 8-pin package
Z8F021AQB020EC	2 KB	512 B	64 B	6	13	2	0	1	1	0	QFN 8-pin package
Z8F021ASB020EC	2 KB	512 B	64 B	6	13	2	0	1	1	0	SOIC 8-pin package
Z8F021ASH020EC	2 KB	512 B	64 B	17	19	2	0	1	1	0	SOIC 20-pin package
Z8F021AHH020EC	2 KB	512 B	64 B	17	19	2	0	1	1	0	SSOP 20-pin package
Z8F021APH020EC	2 KB	512 B	64 B	17	19	2	0	1	1	0	PDIP 20-pin package
Z8F021ASJ020EC	2 KB	512 B	64 B	25	19	2	0	1	1	0	SOIC 28-pin package
Z8F021AHJ020EC	2 KB	512 B	64 B	25	19	2	0	1	1	0	SSOP 28-pin package
Z8F021APJ020EC	2 KB	512 B	64 B	25	19	2	0	1	1	0	PDIP 28-pin package
Replace C with G for Lead-Free Packaging											



Part Number	Flash	RAM	NVDS	I/O Lines	Interrupts	16-Bit Timers w/PWM	10-Bit A/D Channels	UART with IrDA	Comparator	Temperature Sensor	Description
<b>Z8 Encore! XP<sup>®</sup> F082A Series with 1 KB Flash, 10-Bit Analog-to-Digital Converter</b>											
<b>Standard Temperature: 0 °C to 70 °C</b>											
Z8F012APB020SC	1 KB	256 B	16 B	6	14	2	4	1	1	1	PDIP 8-pin package
Z8F012AQB020SC	1 KB	256 B	16 B	6	14	2	4	1	1	1	QFN 8-pin package
Z8F012ASB020SC	1 KB	256 B	16 B	6	14	2	4	1	1	1	SOIC 8-pin package
Z8F012ASH020SC	1 KB	256 B	16 B	17	20	2	7	1	1	1	SOIC 20-pin package
Z8F012AHH020SC	1 KB	256 B	16 B	17	20	2	7	1	1	1	SSOP 20-pin package
Z8F012APH020SC	1 KB	256 B	16 B	17	20	2	7	1	1	1	PDIP 20-pin package
Z8F012ASJ020SC	1 KB	256 B	16 B	23	20	2	8	1	1	1	SOIC 28-pin package
Z8F012AHJ020SC	1 KB	256 B	16 B	23	20	2	8	1	1	1	SSOP 28-pin package
Z8F012APJ020SC	1 KB	256 B	16 B	23	20	2	8	1	1	1	PDIP 28-pin package
<b>Extended Temperature: -40 °C to 105 °C</b>											
Z8F012APB020EC	1 KB	256 B	16 B	6	14	2	4	1	1	1	PDIP 8-pin package
Z8F012AQB020EC	1 KB	256 B	16 B	6	14	2	4	1	1	1	QFN 8-pin package
Z8F012ASB020EC	1 KB	256 B	16 B	6	14	2	4	1	1	1	SOIC 8-pin package
Z8F012ASH020EC	1 KB	256 B	16 B	17	20	2	7	1	1	1	SOIC 20-pin package
Z8F012AHH020EC	1 KB	256 B	16 B	17	20	2	7	1	1	1	SSOP 20-pin package
Z8F012APH020EC	1 KB	256 B	16 B	17	20	2	7	1	1	1	PDIP 20-pin package
Z8F012ASJ020EC	1 KB	256 B	16 B	23	20	2	8	1	1	1	SOIC 28-pin package
Z8F012AHJ020EC	1 KB	256 B	16 B	23	20	2	8	1	1	1	SSOP 28-pin package
Z8F012APJ020EC	1 KB	256 B	16 B	23	20	2	8	1	1	1	PDIP 28-pin package
Replace C with G for Lead-Free Packaging											



Part Number	Flash	RAM	NVDS	I/O Lines	Interrupts	16-Bit Timers w/PWM	10-Bit A/D Channels	UART with IrDA	Comparator	Temperature Sensor	Description
<b>Z8 Encore! XP<sup>®</sup> F082A Series with 1 KB Flash</b>											
<b>Standard Temperature: 0 °C to 70 °C</b>											
Z8F011APB020SC	1 KB	256 B	16 B	6	13	2	0	1	1	0	PDIP 8-pin package
Z8F011AQB020SC	1 KB	256 B	16 B	6	13	2	0	1	1	0	QFN 8-pin package
Z8F011ASB020SC	1 KB	256 B	16 B	6	13	2	0	1	1	0	SOIC 8-pin package
Z8F011ASH020SC	1 KB	256 B	16 B	17	19	2	0	1	1	0	SOIC 20-pin package
Z8F011AHH020SC	1 KB	256 B	16 B	17	19	2	0	1	1	0	SSOP 20-pin package
Z8F011APH020SC	1 KB	256 B	16 B	17	19	2	0	1	1	0	PDIP 20-pin package
Z8F011ASJ020SC	1 KB	256 B	16 B	25	19	2	0	1	1	0	SOIC 28-pin package
Z8F011AHJ020SC	1 KB	256 B	16 B	25	19	2	0	1	1	0	SSOP 28-pin package
Z8F011APJ020SC	1 KB	256 B	16 B	25	19	2	0	1	1	0	PDIP 28-pin package
<b>Extended Temperature: -40 °C to 105 °C</b>											
Z8F011APB020EC	1 KB	256 B	16 B	6	13	2	0	1	1	0	PDIP 8-pin package
Z8F011AQB020EC	1 KB	256 B	16 B	6	13	2	0	1	1	0	QFN 8-pin package
Z8F011ASB020EC	1 KB	256 B	16 B	6	13	2	0	1	1	0	SOIC 8-pin package
Z8F011ASH020EC	1 KB	256 B	16 B	17	19	2	0	1	1	0	SOIC 20-pin package
Z8F011AHH020EC	1 KB	256 B	16 B	17	19	2	0	1	1	0	SSOP 20-pin package
Z8F011APH020EC	1 KB	256 B	16 B	17	19	2	0	1	1	0	PDIP 20-pin package
Z8F011ASJ020EC	1 KB	256 B	16 B	25	19	2	0	1	1	0	SOIC 28-pin package
Z8F011AHJ020EC	1 KB	256 B	16 B	25	19	2	0	1	1	0	SSOP 28-pin package
Z8F011APJ020EC	1 KB	256 B	16 B	25	19	2	0	1	1	0	PDIP 28-pin package
Replace C with G for Lead-Free Packaging											



Part Number	Flash	RAM	NVDS	I/O Lines	Interrupts	16-Bit Timers w/PWM	10-Bit A/D Channels	UART with IrDA	Comparator	Temperature Sensor	Description
<b>Z8 Encore! XP<sup>®</sup> F082A Series Development Kit</b>											
Z8F08A28100KITG											Z8 Encore! XP F082A Series 28-Pin Development Kit
Z8F04A28100KITG											Z8 Encore! XP F042A Series 28-Pin Development Kit
Z8F04A08100KITG											Z8 Encore! XP F042A Series 8-Pin Development Kit
ZUSBSC00100ZACG											USB Smart Cable Accessory Kit
ZUSBOPTSC01ZACG											USB Opto-Isolated Smart Cable Accessory Kit
ZENETSC0100ZACG											Ethernet Smart Cable Accessory Kit

## Part Number Suffix Designations

Z8 F 04 2A S H 020 S C

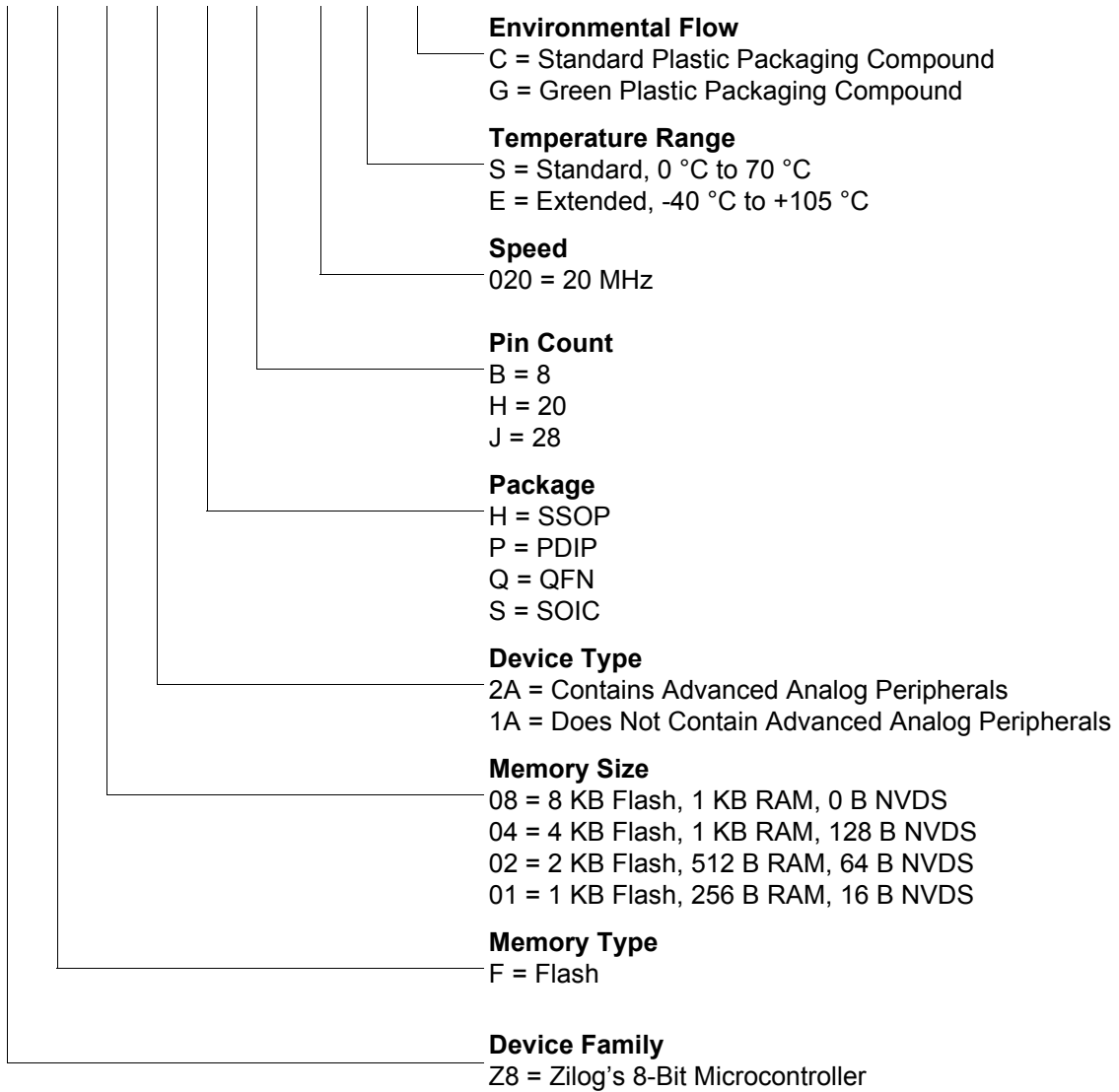

# Index

## Symbols

# 202  
% 202  
@ 202

## Numerics

10-bit ADC 7  
40-lead plastic dual-inline package 248, 249

## A

absolute maximum ratings 221  
AC characteristics 227  
ADC 203  
    architecture 121  
    automatic power-down 122  
    block diagram 122  
    continuous conversion 124  
    control register 130, 132  
    control register definitions 130  
    data high byte register 132  
    data low bits register 133  
    electrical characteristics and timing 231  
    operation 122  
    single-shot conversion 123  
ADCCTL register 130, 132  
ADCDH register 132  
ADCDL register 133  
ADCX 203  
ADD 203  
add - extended addressing 203  
add with carry 203  
add with carry - extended addressing 203  
additional symbols 202  
address space 15  
ADDX 203  
analog signals 12  
analog-to-digital converter (ADC) 121  
AND 205

ANDX 205  
arithmetic instructions 203  
assembly language programming 199  
assembly language syntax 200

## B

B 202  
b 201  
baud rate generator, UART 107  
BCLR 204  
binary number suffix 202  
BIT 204  
bit 201  
    clear 204  
    manipulation instructions 204  
    set 204  
    set or clear 204  
    swap 204  
    test and jump 206  
    test and jump if non-zero 206  
    test and jump if zero 206  
bit jump and test if non-zero 206  
bit swap 206  
block diagram 4  
block transfer instructions 204  
BRK 206  
BSET 204  
BSWAP 204, 206  
BTJ 206  
BTJNZ 206  
BTJZ 206

## C

CALL procedure 206  
CAPTURE mode 85, 86  
CAPTURE/COMPARE mode 85  
cc 201  
CCF 204  
characteristics, electrical 221  
clear 205  
CLR 205  
COM 205



- compare 85
- compare - extended addressing 203
- COMPARE mode 85
- compare with carry 203
- compare with carry - extended addressing 203
- complement 205
- complement carry flag 204
- condition code 201
- continuous conversion (ADC) 124
- CONTINUOUS mode 84
- control register definition, UART 108
- Control Registers 15, 19
- COUNTER modes 84
- CP 203
- CPC 203
- CPCX 203
- CPU and peripheral overview 5
- CPU control instructions 204
- CPX 203
- Customer Feedback Form 271

## D

- DA 201, 203
- data memory 17
- DC characteristics 222
- debugger, on-chip 173
- DEC 203
- decimal adjust 203
- decrement 203
- decrement and jump non-zero 206
- decrement word 203
- DECW 203
- destination operand 202
- device, port availability 37
- DI 204
- direct address 201
- disable interrupts 204
- DJNZ 206
- dst 202

## E

- EI 204

- electrical characteristics 221
  - ADC 231
  - flash memory and timing 230
  - GPIO input data sample timing 234
  - Watchdog Timer 230, 233
- enable interrupt 204
- ER 201
- extended addressing register 201
- external pin reset 27
- eZ8 CPU features 5
- eZ8 CPU instruction classes 202
- eZ8 CPU instruction notation 200
- eZ8 CPU instruction set 199
- eZ8 CPU instruction summary 207

## F

- FCTL register 149, 155, 156
- features, Z8 Encore! 1
- first opcode map 218
- FLAGS 202
- flags register 202
- flash
  - controller 7
  - option bit address space 156
  - option bit configuration - reset 153
  - program memory address 0000H 156
  - program memory address 0001H 158
- flash memory 141
  - arrangement 142
  - byte programming 147
  - code protection 145
  - configurations 141
  - control register definitions 149, 155
  - controller bypass 148
  - electrical characteristics and timing 230
  - flash control register 149, 155, 156
  - flash option bits 146
  - flash status register 150
  - flow chart 144
  - frequency high and low byte registers 152
  - mass erase 147
  - operation 143
  - operation timing 145

page erase 147  
page select register 150, 151  
FPS register 150, 151  
FSTAT register 150

## G

GATED mode 85  
general-purpose I/O 37  
GPIO 7, 37  
alternate functions 38  
architecture 38  
control register definitions 45  
input data sample timing 234  
interrupts 45  
port A-C pull-up enable sub-registers 50, 51  
port A-H address registers 46  
port A-H alternate function sub-registers 47  
port A-H control registers 46  
port A-H data direction sub-registers 47  
port A-H high drive enable sub-registers 49  
port A-H input data registers 51  
port A-H output control sub-registers 48  
port A-H output data registers 52  
port A-H stop mode recovery sub-registers 49  
port availability by device 37  
port input timing 235  
port output timing 236

## H

H 202  
HALT 204  
halt mode 34, 204  
hexadecimal number prefix/suffix 202

## I

I2C 7  
IM 201  
immediate data 201  
immediate operand prefix 202

INC 203  
increment 203  
increment word 203  
INCW 203  
indexed 201  
indirect address prefix 202  
indirect register 201  
indirect register pair 201  
indirect working register 201  
indirect working register pair 201  
infrared encoder/decoder (IrDA) 117  
Instruction Set 199  
instruction set, eZ8 CPU 199  
instructions  
ADC 203  
ADCX 203  
ADD 203  
ADDX 203  
AND 205  
ANDX 205  
arithmetic 203  
BCLR 204  
BIT 204  
bit manipulation 204  
block transfer 204  
BRK 206  
BSET 204  
BSWAP 204, 206  
BTJ 206  
BTJNZ 206  
BTJZ 206  
CALL 206  
CCF 204  
CLR 205  
COM 205  
CP 203  
CPC 203  
CPCX 203  
CPU control 204  
CPX 203  
DA 203  
DEC 203  
DECW 203  
DI 204

DJNZ 206  
 EI 204  
 HALT 204  
 INC 203  
 INCW 203  
 IRET 206  
 JP 206  
 LD 205  
 LDC 205  
 LDCI 204, 205  
 LDE 205  
 LDEI 204  
 LDX 205  
 LEA 205  
 logical 205  
 MULT 203  
 NOP 204  
 OR 205  
 ORX 206  
 POP 205  
 POPX 205  
 program control 206  
 PUSH 205  
 PUSHX 205  
 RCF 204  
 RET 206  
 RL 206  
 RLC 206  
 rotate and shift 206  
 RR 206  
 RRC 206  
 SBC 203  
 SCF 204, 205  
 SRA 207  
 SRL 207  
 SRP 205  
 STOP 205  
 SUB 203  
 SUBX 203  
 SWAP 207  
 TCM 204  
 TCMX 204  
 TM 204  
 TMX 204  
 TRAP 206  
 Watchdog Timer refresh 205  
 XOR 206  
 XORX 206  
 instructions, eZ8 classes of 202  
 interrupt control register 67  
 interrupt controller 55  
     architecture 55  
     interrupt assertion types 58  
     interrupt vectors and priority 58  
     operation 57  
     register definitions 60  
     software interrupt assertion 59  
 interrupt edge select register 66  
 interrupt request 0 register 60  
 interrupt request 1 register 61  
 interrupt request 2 register 62  
 interrupt return 206  
 interrupt vector listing 55  
 interrupts  
     UART 105  
 IR 201  
 Ir 201  
 IrDA  
     architecture 117  
     block diagram 117  
     control register definitions 120  
     operation 117  
     receiving data 119  
     transmitting data 118  
 IRET 206  
 IRQ0 enable high and low bit registers 62  
 IRQ1 enable high and low bit registers 63  
 IRQ2 enable high and low bit registers 65  
 IRR 201  
 Irr 201  
  
**J**  
 JP 206  
 jump, conditional, relative, and relative conditional 206

## L

- LD 205
- LDC 205
- LDCI 204, 205
- LDE 205
- LDEI 204, 205
- LDX 205
- LEA 205
- load 205
- load constant 204
- load constant to/from program memory 205
- load constant with auto-increment addresses 205
- load effective address 205
- load external data 205
- load external data to/from data memory and auto-increment addresses 204
- load external to/from data memory and auto-increment addresses 205
- load using extended addressing 205
- logical AND 205
- logical AND/extended addressing 205
- logical exclusive OR 206
- logical exclusive OR/extended addressing 206
- logical instructions 205
- logical OR 205
- logical OR/extended addressing 206
- low power modes 33

## M

- master interrupt enable 57
- memory
  - data 17
  - program 15
- mode
  - CAPTURE 85, 86
  - CAPTURE/COMPARE 85
  - CONTINUOUS 84
  - COUNTER 84
  - GATED 85
  - ONE-SHOT 84
  - PWM 85
- modes 85

- MULT 203
- multiply 203
- multiprocessor mode, UART 103

## N

- NOP (no operation) 204
- notation
  - b 201
  - cc 201
  - DA 201
  - ER 201
  - IM 201
  - IR 201
  - lr 201
  - IRR 201
  - lrr 201
  - p 201
  - R 201
  - r 201
  - RA 201
  - RR 201
  - rr 201
  - vector 201
  - X 201
- notational shorthand 201

## O

- OCD
  - architecture 173
  - auto-baud detector/generator 176
  - baud rate limits 177
  - block diagram 173
  - breakpoints 178
  - commands 179
  - control register 184
  - data format 176
  - DBG pin to RS-232 Interface 174
  - debug mode 175
  - debugger break 206
  - interface 174
  - serial errors 177
  - status register 185

- timing 237
- OCD commands
  - execute instruction (12H) 183
  - read data memory (0DH) 183
  - read OCD control register (05H) 181
  - read OCD revision (00H) 180
  - read OCD status register (02H) 180
  - read program counter (07H) 181
  - read program memory (0BH) 182
  - read program memory CRC (0EH) 183
  - read register (09H) 182
  - read runtime counter (03H) 180
  - step instruction (10H) 183
  - stuff instruction (11H) 183
  - write data memory (0CH) 182
  - write OCD control register (04H) 181
  - write program counter (06H) 181
  - write program memory (0AH) 182
  - write register (08H) 181
- on-chip debugger (OCD) 173
- on-chip debugger signals 12
- on-chip oscillator 193
- ONE-SHOT mode 84
- opcode map
  - abbreviations 217
  - cell description 216
  - first 218
  - second after 1FH 219
- Operational Description 23, 33, 37, 55, 69, 91, 97, 117, 121, 134, 135, 139, 141, 153, 169, 173, 187, 193, 197
- OR 205
- ordering information 251
- ORX 206
- oscillator signals 12

## P

- p 201
- packaging
  - 20-pin PDIP 244, 245
  - 20-pin SSOP 246, 249
  - 28-pin PDIP 247
  - 28-pin SOIC 248

- 8-pin PDIP 241
- 8-pin SOIC 242
- PDIP 248, 249
- part selection guide 2
- PC 202
- PDIP 248, 249
- peripheral AC and DC electrical characteristics 229
- pin characteristics 13
- Pin Descriptions 9
- polarity 201
- POP 205
- pop using extended addressing 205
- POPX 205
- port availability, device 37
- port input timing (GPIO) 235
- port output timing, GPIO 236
- power supply signals 13
- power-down, automatic (ADC) 122
- Power-on and Voltage Brownout electrical characteristics and timing 229
- Power-On Reset (POR) 25
- program control instructions 206
- program counter 202
- program memory 15
- PUSH 205
- push using extended addressing 205
- PUSHX 205
- PWM mode 85
- PxADDR register 46
- PxCTL register 47

## R

- R 201
- r 201
- RA
  - register address 201
- RCF 204
- receive
  - IrDA data 119
- receiving UART data-interrupt-driven method 102
- receiving UART data-pollled method 101

- register 201
  - ADC control (ADCCTL) 130, 132
  - ADC data high byte (ADCDH) 132
  - ADC data low bits (ADCDL) 133
  - flash control (FCTL) 149, 155, 156
  - flash high and low byte (FFREQH and FREEQL) 152
  - flash page select (FPS) 150, 151
  - flash status (FSTAT) 150
  - GPIO port A-H address (PxADDR) 46
  - GPIO port A-H alternate function sub-registers 48
  - GPIO port A-H control address (PxCTL) 47
  - GPIO port A-H data direction sub-registers 47
  - OCD control 184
  - OCD status 185
  - UARTx baud rate high byte (UxBRH) 114
  - UARTx baud rate low byte (UxBRL) 114
  - UARTx Control 0 (UxCTL0) 108, 114
  - UARTx control 1 (UxCTL1) 109
  - UARTx receive data (UxRXD) 113
  - UARTx status 0 (UxSTAT0) 111
  - UARTx status 1 (UxSTAT1) 112
  - UARTx transmit data (UxTXD) 113
  - Watchdog Timer control (WDTCTL) 31, 94, 136, 190
  - Watchdog Timer reload high byte (WDTH) 95
  - Watchdog Timer reload low byte (WDTL) 95
  - Watchdog Timer reload upper byte (WDTU) 95
- register file 15
- register pair 201
- register pointer 202
- reset
  - and stop mode characteristics 24
  - and Stop Mode Recovery 23
  - carry flag 204
  - sources 25
- RET 206
- return 206
- RL 206
- RLC 206
- rotate and shift instructions 206
- rotate left 206
- rotate left through carry 206
- rotate right 206
- rotate right through carry 206
- RP 202
- RR 201, 206
- rr 201
- RRC 206
- S**
- SBC 203
- SCF 204, 205
- second opcode map after 1FH 219
- set carry flag 204, 205
- set register pointer 205
- shift right arithmetic 207
- shift right logical 207
- signal descriptions 11
- single-shot conversion (ADC) 123
- software trap 206
- source operand 202
- SP 202
- SRA 207
- src 202
- SRL 207
- SRP 205
- stack pointer 202
- STOP 205
- STOP mode 33
- stop mode 205
- Stop Mode Recovery
  - sources 28
  - using a GPIO port pin transition 29
  - using Watchdog Timer time-out 29
- stop mode recovery
  - sources 30
  - using a GPIO port pin transition 30
- SUB 203
- subtract 203
- subtract - extended addressing 203
- subtract with carry 203

subtract with carry - extended addressing 203  
SUBX 203  
SWAP 207  
swap nibbles 207  
symbols, additional 202

## T

TCM 204  
TCMX 204  
Technical Support 271  
test complement under mask 204  
test complement under mask - extended addressing 204  
test under mask 204  
test under mask - extended addressing 204  
timer signals 11  
timers 69  
    architecture 69  
    block diagram 70  
    CAPTURE mode 77, 78, 85, 86  
    CAPTURE/COMPARE mode 81, 85  
    COMPARE mode 79, 85  
    CONTINUOUS mode 71, 84  
    COUNTER mode 72, 73  
    COUNTER modes 84  
    GATED mode 80, 85  
    ONE-SHOT mode 70, 84  
    operating mode 70  
    PWM mode 74, 76, 85  
    reading the timer count values 82  
    reload high and low byte registers 87  
    timer control register definitions 83  
    timer output signal operation 82  
timers 0-3  
    control registers 83, 84  
    high and low byte registers 87, 88  
TM 204  
TMX 204  
transmit  
    IrDA data 118  
transmitting UART data-polled method 99  
transmitting UART dat-interrupt-driven method 100

TRAP 206

## U

UART 7  
    architecture 97  
    baud rate generator 107  
    baud rates table 115  
    control register definitions 108  
    controller signals 11  
    data format 98  
    interrupts 105  
    multiprocessor mode 103  
    receiving data using interrupt-driven method 102  
    receiving data using the polled method 101  
    transmitting data usin the interrupt-driven method 100  
    transmitting data using the polled method 99  
    x baud rate high and low registers 114  
    x control 0 and control 1 registers 108  
    x status 0 and status 1 registers 111, 112  
UxBRH register 114  
UxBRL register 114  
UxCTL0 register 108, 114  
UxCTL1 register 109  
UxRXD register 113  
UxSTAT0 register 111  
UxSTAT1 register 112  
UxTXD register 113

## V

vector 201  
Voltage Brownout reset (VBR) 26

## W

Watchdog Timer  
    approximate time-out delay 91  
    approximate time-out delays 135  
CNTL 26  
    control register 94, 136, 190

- electrical characteristics and timing 230, 233
- interrupt in normal operation 92
- interrupt in STOP mode 92
- operation 135
- refresh 92, 205
- reload unlock sequence 93
- reload upper, high and low registers 94
- reset 27
- reset in normal operation 93
- reset in STOP mode 93
- time-out response 92
- WDTCTL register 31, 94, 136, 190
- WDTH register 95
- WDTL register 95
- working register 201
- working register pair 201
- WTDU register 95

## **X**

- X 201
- XOR 206
- XORX 206

## **Z**

- Z8 Encore!
  - block diagram 4
  - features 1
  - part selection guide 2





# Customer Support

For answers to technical questions about the product, documentation, or any other issues with Zilog's offerings, please visit Zilog's Knowledge Base at <http://www.zilog.com/kb>.

For any comments, detail technical questions, or reporting problems, please visit Zilog's Technical Support at <http://support.zilog.com>.