

Specification

Small Form Factor Pluggable

Duplex LC Receptacle – SFP+

Optical Transceivers

10 Gigabit Ethernet

10GBASE-LR



Ordering Information

TAS-A2NB1-FAH

Model Name	Voltage	Category	Device type	Interface	Temperature	Distance	Latch Color
TAS-A2NB1-FAH	3.3V	With DDMI	1310 nm DFB	AC / AC LVTTTL	-40°C ~+85°C	10km	Blue 

Features

- Optical Interface compliant to IEEE 802.3ae 10GBASE-LR/LW
- Compliant with SFP+ MSA
- Data Rate 10.3125Gbps
- 1310nm DFB TOSA and PIN ROSA
- Applicable for 10 km SMF connection
- LC duplex receptacle
- Low power dissipation (< 1W)
- Hot Pluggable
- All-metal housing for superior EMI performance
- Built in digital diagnostic Functions
- Operating case temperature range: Commercial Temperature -40°C ~ 85°C
- ROHS Compliant

Applications

- 10GBASE-LR 10Gigabit Ethernet
- High-speed storage area networks
- Computer cluster cross-connect
- Custom high-speed data pipes

Transceiver Block Diagram

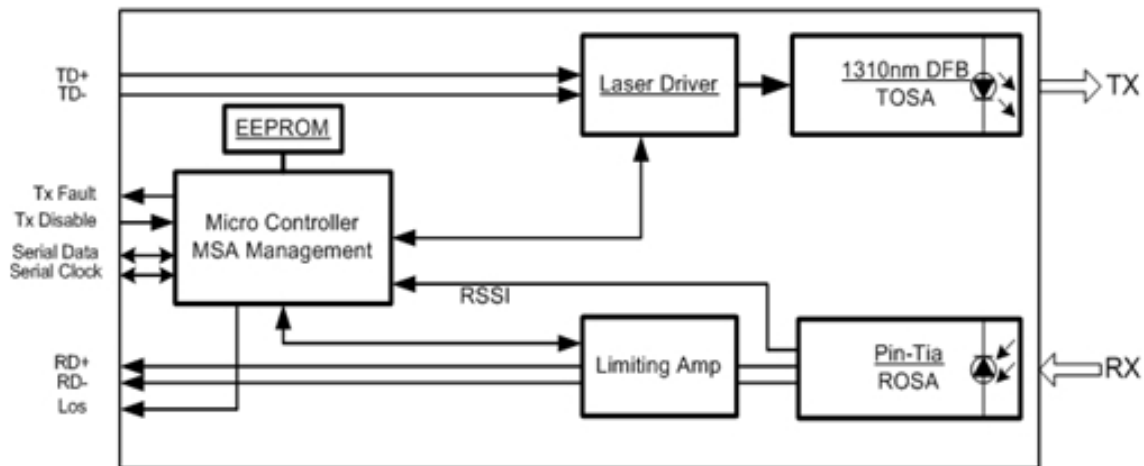

Proposed Applications Schematics

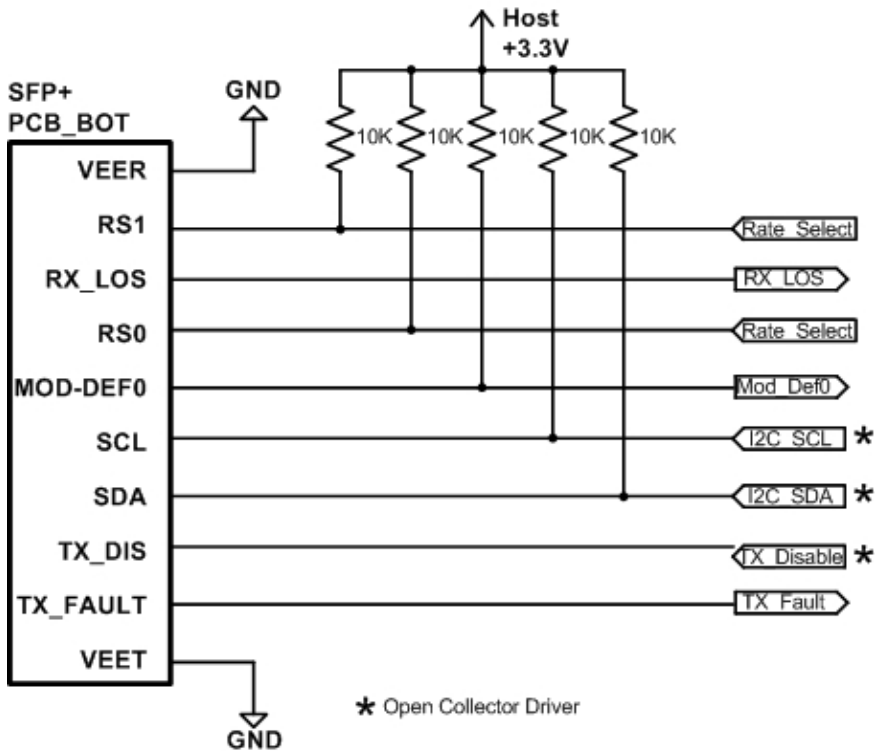
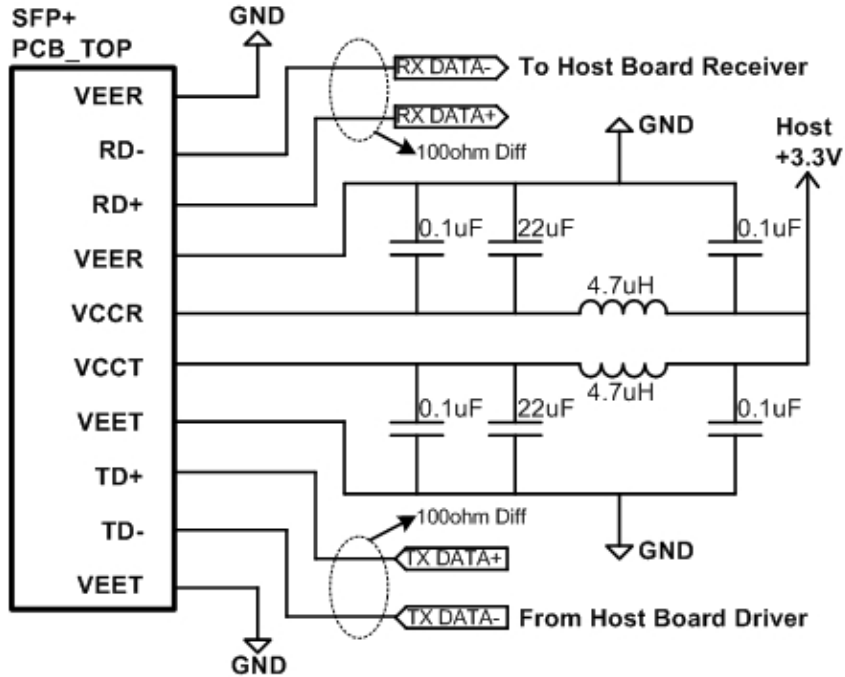

Pin Definition and Descriptions

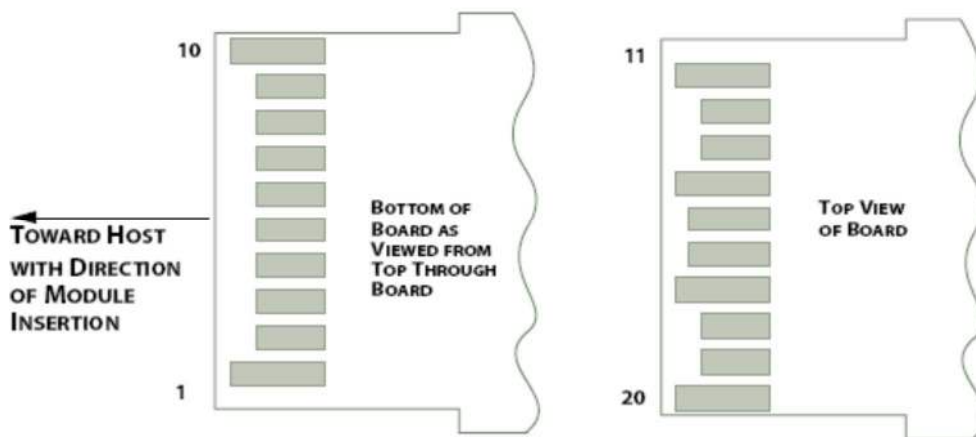
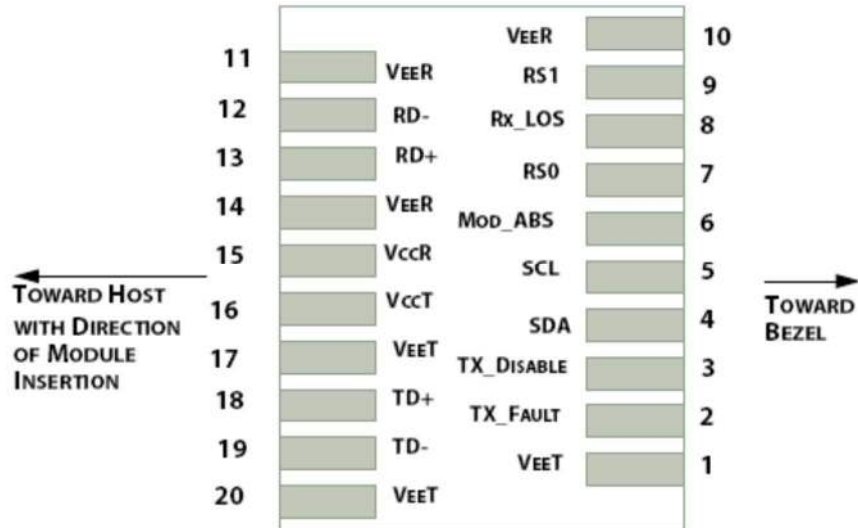

PIN	Logic	Symbol	Name / Description	Note
1		VeeT	Module Transmitter Ground	1
2	LVTTL-O	TX_Fault	Module Transmitter Fault	2
3	LVTTL-I	TX_Dis	Transmitter Disable; Turns off transmitter laser output	3
4	LVTTL-I/O	SDA	2-Wire Serial Interface Data Line	
5	LVTTL-I	SCL	2-Wire Serial Interface Clock	
6		Mod_ABS	Module Absent, connected to VeeT or VeeR in the module	
7	LVTTL-I	RS0	Rate Select 0, optionally controls SFP+ module receiver. When high input signaling rate > 4.25 GBd and when low input signal rate \leq 4.25 GBd.	
8	LVTTL-O	RX_LOS	Receiver Loss of Signal Indication	
9	LVTTL-I	RS1	Rate Select 1, optionally controls SFP+ module transmitter. When high input signaling rate > 4.25 GBd and when low input signal rate \leq 4.25 GBd.	
10		VeeR	Module Receiver Ground	1
11		VeeR	Module Receiver Ground	1
12	CML-O	RD-	Receiver Inverted Data Output	
13	CML-O	RD+	Receiver Data Output	
14		VeeR	Module Receiver Ground	1
15		VccR	Module Receiver 3.3 V Supply	
16		VccT	Module Transmitter 3.3 V Supply	
17		VeeT	Module Transmitter Ground	1
18	CML-I	TD+	Transmitter Non-Inverted Data Input	
19	CML-I	TD-	Transmitter Inverted Data Input	
20		VeeT	Module Transmitter Ground	1

Note:

1. Module ground pins are isolated from the module case and chassis ground within the module.
2. Shall be pulled up with 4.7k to 10k ohm to a voltage between 3.15V and 3.45V on the host board.
3. Shall be pulled up with 4.7k to 10k ohm to VccT in the module.

Absolute Maximum Ratings

Parameters	Symbol	Min.	Max.	Unit
Power Supply Voltage	V _{CC}	0	3.6	V
Storage Temperature	T _s	-40	85	°C
Relative Humidity	RH	5	95	%
Optical Receiver Power (Damage)	P _{max}		1.5	dBm

Recommended Operating Environment

Parameters	Symbol	Min.	Typical	Max	Unit
Power Supply Voltage	V _{CC}	3.135	3.3	3.465	V
Operating Case Temperature	T _{op}	-40		85	°C
Power Supply Current	I _{CC}			300	mA
Power Consumption			800	1000	mW
Data rate			10.3125		Gbps

Optical Characteristics

Parameter	Symbol	Min.	Typ.	Max	Unit	Notes
Transmitter						
Average Launch Power	P _o	-8.2	---	0.5	dBm	
Center wavelength	λ	1260	---	1355	nm	
Side Mode Suppression Ratio	SMSR	30	---	---	nm	
Extinction ratio	ER	3.5	---	---	dB	
Transmitter and dispersion penalty(max)	TDP	---	---	3.2	dB	
Optical power OMA	P _{OMA}	-5.2	---	---	dBm	
OMA-TDP	P _{OMA-TDP}	-6.2	---	---	dBm	
Average launch power of OFF transmitted	P _{off}	---	---	-30	dBm	
RIN ₁₂ OMA	RIN	---	---	-128	dB/Hz	
Optical Return Loss Tolerance		12	---	---	dB	
Output eye	Compliant with IEEE802.3ae eye mask					
Receiver						
Center wavelength	λ	1260		1355	nm	
Average receiver power(max)	P _{max}			0.5	dBm	
Average receiver power(min)	P _{min}	-14.4			dBm	
Receiver Reflectance	R _{rx}			-12	dB	
Receiver Sensitivity in OMA				-12.6	dBm	
Stressed Sensitivity in OMA				-10.3	dBm	1
Vertical eye closure penalty		2.2			dB	2
Stressed eye jitter		0.3			Ulp-p	1
LOS	Assert	LOS _A	-30		dBm	
	Deassert	LOS _D		-12	dBm	
LOS Hysteresis	LOS _H	0.5			dB	

Note:

1. Receiver sensitivity is informative. Stressed receiver sensitivity shall be measured with conformance test signal for BER =1x 10⁻¹².
2. Vertical eye closure penalty and stressed eye jitter are the test conditions for measuring stressed receiver sensitivity. They are not the required characteristic of the receiver.

Electrical Characteristics

Parameter	Symbol	Min.	Typical	Max	Unit	Notes
Data Rate		-	10.3125	-	Gbps	
Transmitter						
Transmitter Differential Input Voltage	V _{IN}	180	-	700	mV	
Transmitter Disable (TX-Disable)	V _{IH}	2		V _{CC}	V	
	V _{IL}	V _{EE}		V _{EE} +0.8		
Receiver						
Receiver Differential Output Voltage	V _O	300	-	850	mV	
Loss of Signal (LOS)	V _{OH}	2		V _{CC}	V	
	V _{OL}	V _{EE}		V _{EE} +0.8		
Rx Output Rise and Fall Time	Tr/Tf	30			ps	20% to 80%

Control And Status I/O Timing Characteristics

Parameter	Symbol	Min	Max	Unit	Condition
TX Disable Assert Time	t _{off}		10	μs	Time from rising edge of TX Disable to when the optical output falls below 10% of nominal
TX Disable Negate Time	t _{on}		1	ms	Time from falling edge of TX Disable to when the modulated optical output rises above 90% of nominal
Time to initialize, including reset of TX_Fault	t _{init}		300	ms	From power on or negation of TX Fault using TX Disable
TX Fault Assert Time	t _{fault}		100	μs	Time from fault to TX fault on.
TX Disable to reset	t _{reset}	10		μs	Time TX Disable must be held high to reset TX_fault
LOS Assert Time	t _{loss_on}		100	μs	Time from LOS state to RX LOS assert
LOS Deassert Time	t _{loss_off}		100	μs	Time from non-LOS state to RX LOS deassert
Rate-Select Change Time	t _{ratesel}		10	μs	Time from rising or falling edge of Rate Select input until receiver bandwidth is in conformance with appropriate specification.
Serial ID Clock Rate	f _{serial_clock}		100	kHz	

Digital Diagnostic Functions

Parameter	Symbol	Min.	Max	Unit	Notes
Temperature monitor absolute error	DMI_Temp	-3	3	degC	Over operating temp
Laser power monitor absolute error	DMI_TX	-3	3	dB	
RX power monitor absolute error	DMI_RX	-3	3	dB	-1dBm to -12dBm range
Supply voltage monitor absolute error	DMI_VCC	-0.08	0.08	V	Full operating range
Bias current monitor	DMI_Ibias	-10%	10%	mA	

Digital Diagnostic Memory Map

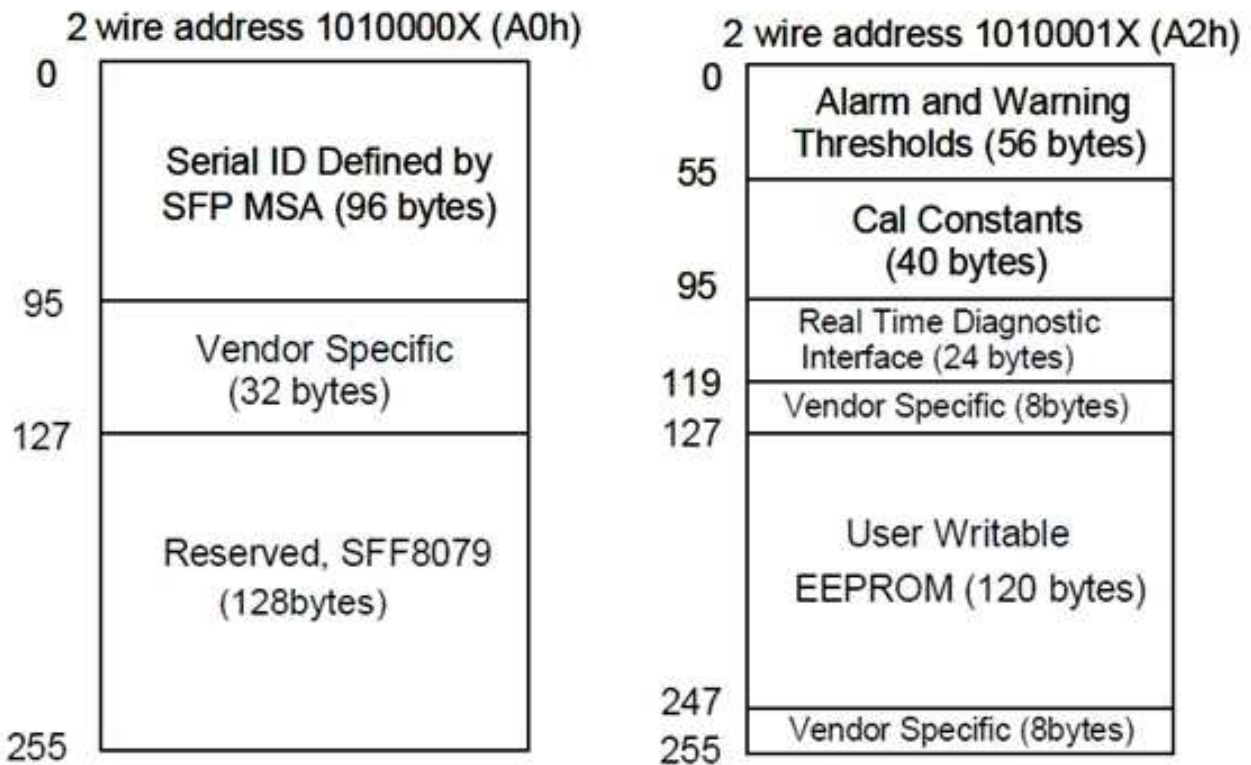

Mechanical (mm)

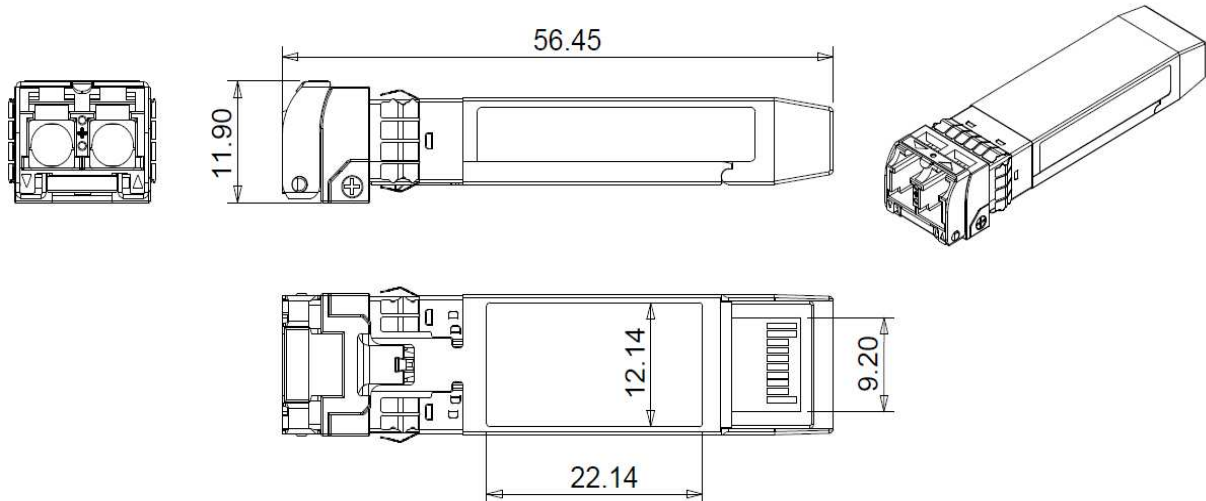

ESD

Normal ESD precautions are required during the handling of this module. This transceiver is shipped in ESD protective packaging. It should be removed from the packaging and handled only in an ESD protected environment.

LASER Safety

This is a Class 1 Laser Product according to IEC / EN 60825-1: 2014 (Third Edition). This product complies with 21 CFR 1040.10 and 1040.11 except for deviations pursuant to Laser Notice No. 50, dated (June 24, 2007)



Contact Information

Formerica OptoElectronics Inc.

5F-11, No.38, Taiyuan St., Zhubei City,
Hsinchu County 30265, Taiwan

Tel: +886-3-5600286

Fax: +886-3-5600239

San Diego, CA

Tel: 1-949-466-8069

inquiry@formericaoe.com

www.formericaoe.com