

OV5675 5-megapixel product brief



The Industry's Smallest 5-Megapixel PureCel® Sensor for Smartphones and Tablets



available in
a lead-free
package

OmniVision's high performance OV5675 is a 5-megapixel PureCel sensor designed to bring high quality imaging capabilities to front- and rear-facing cameras in smartphones and tablets. The industry's smallest 5-megapixel currently available, the cost-effective OV5675 offers dramatically improved image and video quality in a compact and power-efficient package.

The 1/5-inch sensor can capture full resolution 5-megapixel images in a native 4:3 aspect ratio at 30 frames per second (fps), or 720p high definition (HD) and 1080p video at 60 fps. Additionally, the OV5675 supports ultra-low power mode, which enables QVGA video recording at 30 fps while requiring less than 25 mW.

The OV5675 fits into a compact 5.5 x 5.5 x 3.5 mm module.

Find out more at www.ovt.com.



Applications

- Smartphones and Feature Phones
- Tablets
- PC Multimedia
- Wearables

Product Features

- 1.12 μm x 1.12 μm pixel
- 5MP at 30 fps
- programmable controls for:
 - frame rate
 - mirror and flip
 - cropping
 - windowing
- supports images sizes:
 - 5MP (2592x1944)
 - quad HD (2560x1440)
 - 1080p (1920x1080)
 - 720p (1280x720)
 - VGA (640x480), and more
- 260 bytes of embedded one-time programmable (OTP) memory for customer use
- support for output formats:
 - 10-bit RGB RAW
- interleave row HDR output
- two-wire serial bus control (SCCB)
- MIPI serial output interface (1- or 2-lane)
- 2x binning support
- image quality control:
 - defect pixel correction
 - automatic black level calibration

OV5675



Ordering Information

- OV05675-GA4A**
(color, chip probing, 200 μm backgrinding, reconstructed wafer)

Product Specifications

- active array size:** 2592 x 1944
- power supply:**
 - core: 1.14 - 1.26V (1.2V nominal)
 - analog: 2.6 - 3.0V (2.8V nominal)
 - I/O: 1.7 - 1.9V (1.8V nominal)
- power requirements:**
 - active: 96 mW
 - standby: 165 μW
 - XSHUTDOWN: 1 μW
- temperature range:**
 - operating: -30°C to +85°C junction temperature
 - stable image: -20°C to +60°C junction temperature
- output interface:** 2-lane MIPI serial output
- output formats:** 10-bit RGB RAW
- lens size:** 1/5"
- lens chief ray angle:** 31.24° non-linear
- input clock frequency:** 6 - 27 MHz
- maximum image transfer rate:**
 - 5MP (2592x1944): 30 fps
 - quad HD (2560x1440): 30 fps
 - 1080p (1920x1080): 60 fps
 - 720p (1280x720): 60 fps
 - VGA (640x480): 120 fps
- sensitivity:** 530 mV/lux-sec
- max S/N ratio:** 35.7 dB
- dynamic range:** 69.7 dB @ 16x gain
- pixel size:** 1.12 μm x 1.12 μm
- dark current:** 6 e⁻/sec @ 60°C junction temperature
- image area:** 2928.384 μm x 2205.216 μm
- dimensions:**
 - COB: 3771 μm x 3226.5 μm
 - RW: 3821 μm x 3276.5 μm

Functional Block Diagram

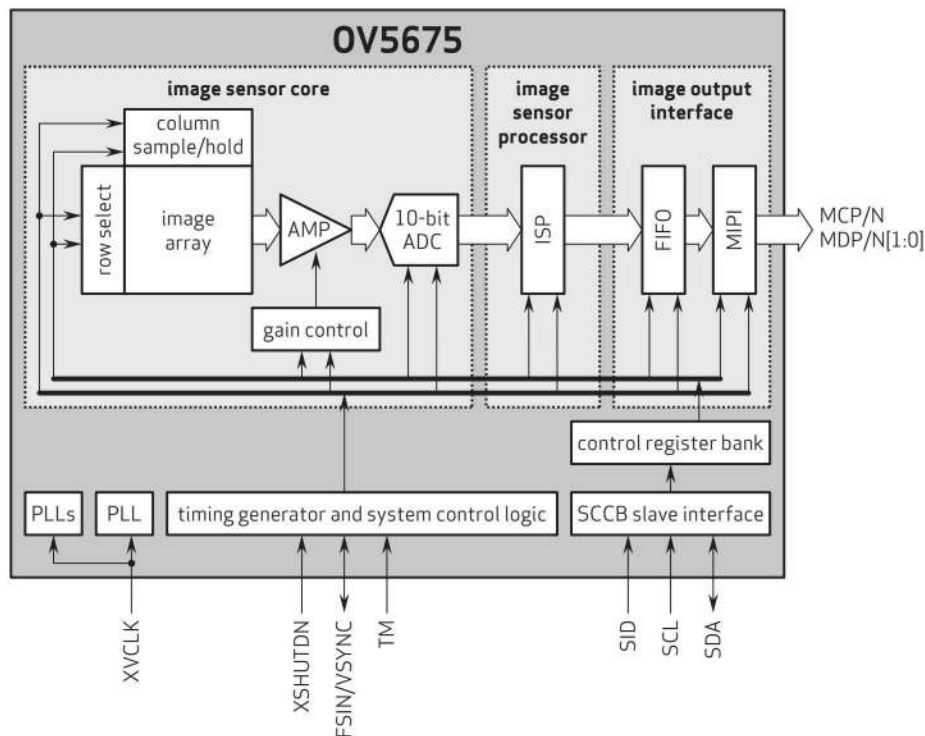

4275 Burton Drive
Santa Clara, CA 95054
USA

Tel: +1 408 567 3000
Fax: +1 408 567 3001
www.ovt.com

OmniVision reserves the right to make changes to their products or to discontinue any product or service without further notice. OmniVision, the OmniVision logo, OmniPixel, and PureCel are registered trademarks of OmniVision Technologies, Inc. All other trademarks are the property of their respective owners.



OmniVision