



STEVAl-IHM028V1

2 kW 3-phase motor control demonstration board featuring the IGBT intelligent power module STGIPSS20K60

Data brief

Features

- Complete solution for a 2 kW power inverter
- HV supply mode: voltage 90 VAC to 285 VAC or direct DC line: 125 V DC to 400 V DC
- Input voltage range extended to +400 V to be compliant with PFC
- Input inrush limiter with bypassing relay
- Brake feature with overvoltage comparator
- Single or three shunt resistors current sensing method
- Hall sensor or encoder input feature
- Tachometer input feature
- Overtemperature and overcurrent hardware protection
- Active fan with automatic overtemperature switching
- Compact and safe design
- Universal conception for further evaluation with bread board and testing pins
- RoHS compliant

Description

The goal of the STEVAL-IHM028V1 demonstration board is to present a universal, fully tested, and populated design consisting of a 3-phase inverter bridge based on the 600 V, 17 A intelligent power module STGIPSS20K60. The IPM itself consists of short-circuit rugged IGBTs with negative temperature co-efficiency. It also contains a wide range of auxiliary functions like undervoltage lockout and smart shutdown.

Thanks to these advanced characteristics, the system has been specifically designed to achieve an accurate and fast conditioning of the current feedback, therefore matching the typical requirements for a field oriented control (FOC).

This demonstration board can be used for evaluating a wide range of applications such as



HVAC (air conditioners), power white goods and high end single-phase power tools.

February 2011

Doc ID 010011 Rev 1

1/9

1 Schematics

Figure 1. Schematic 1/6

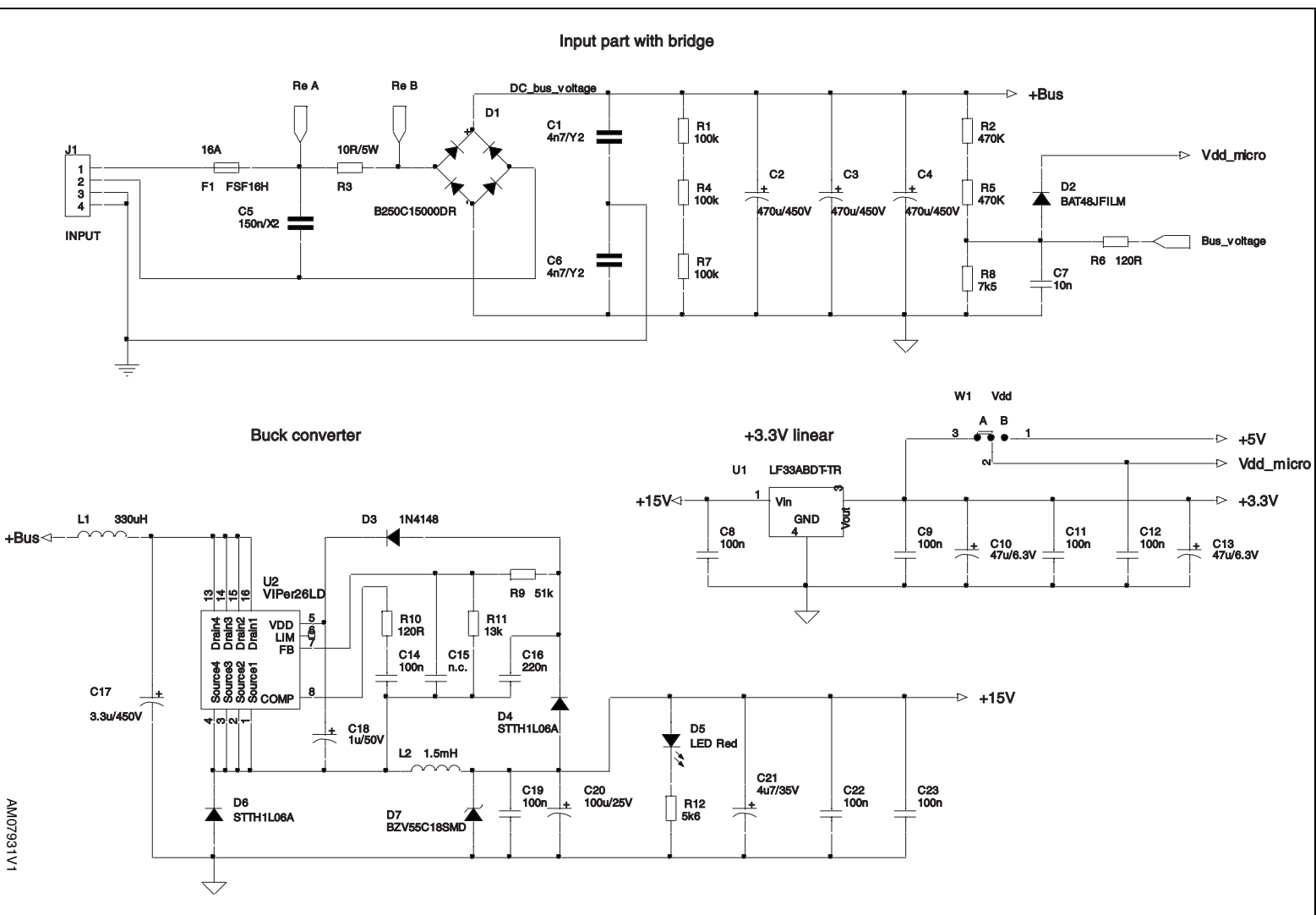

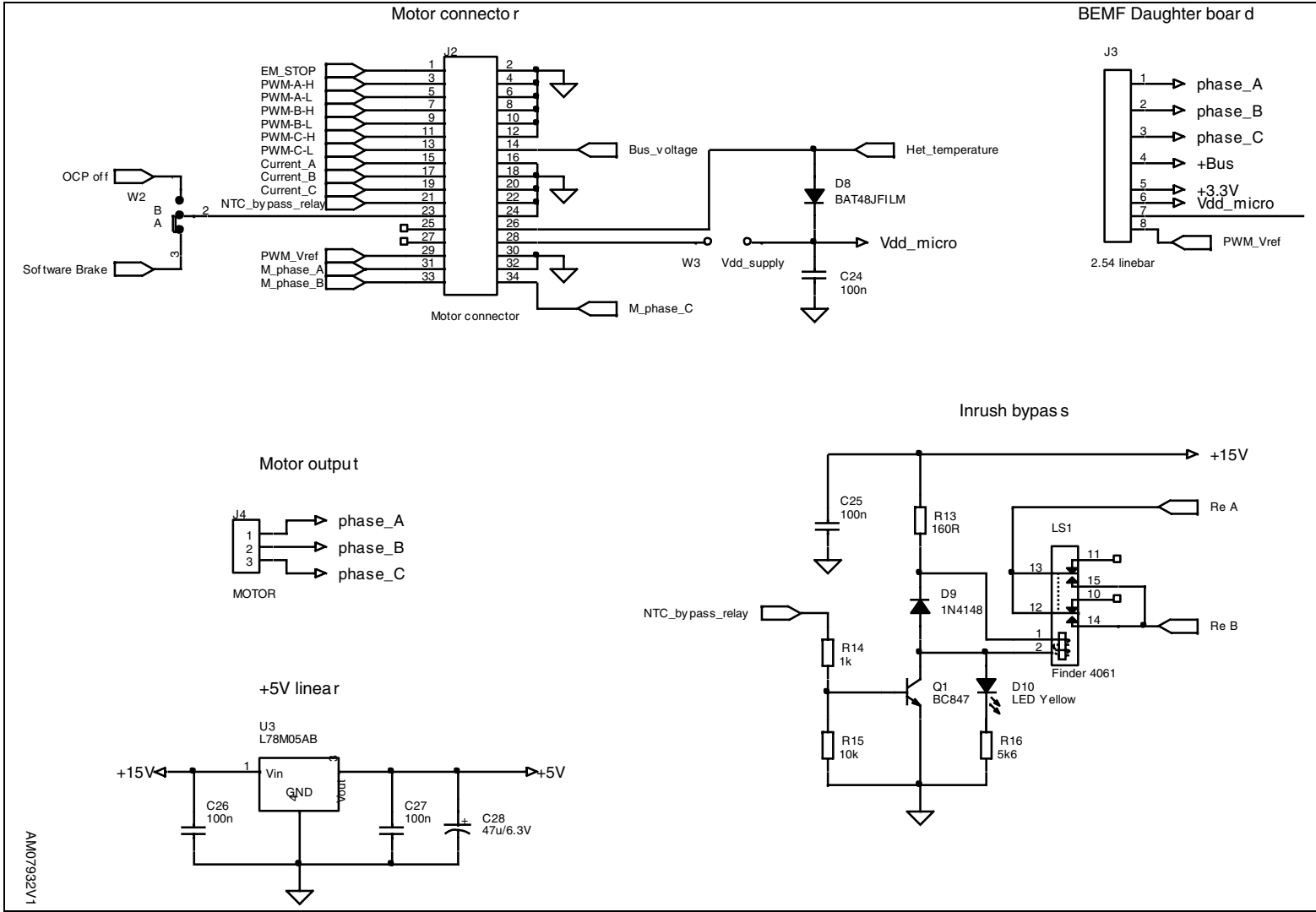
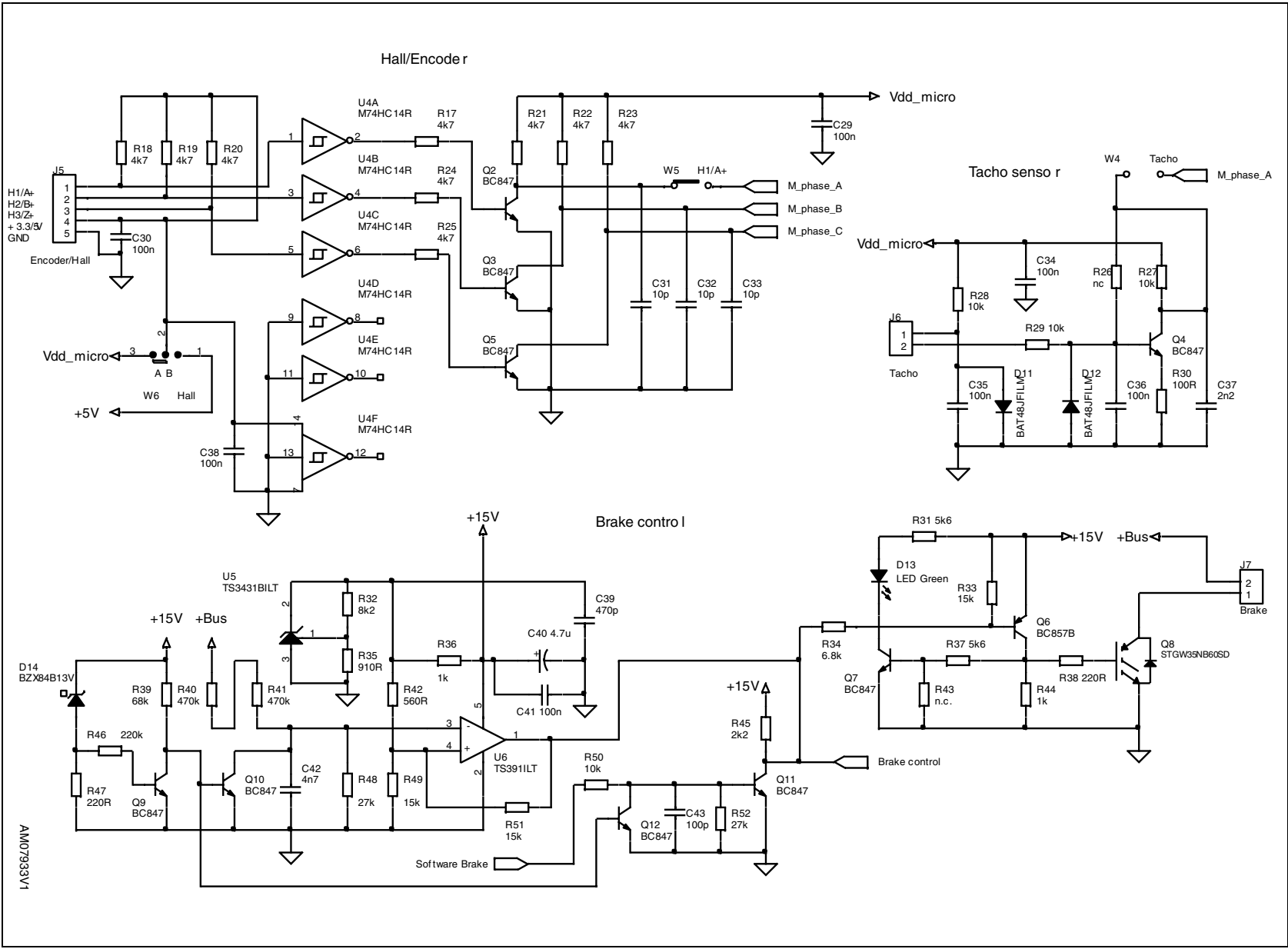
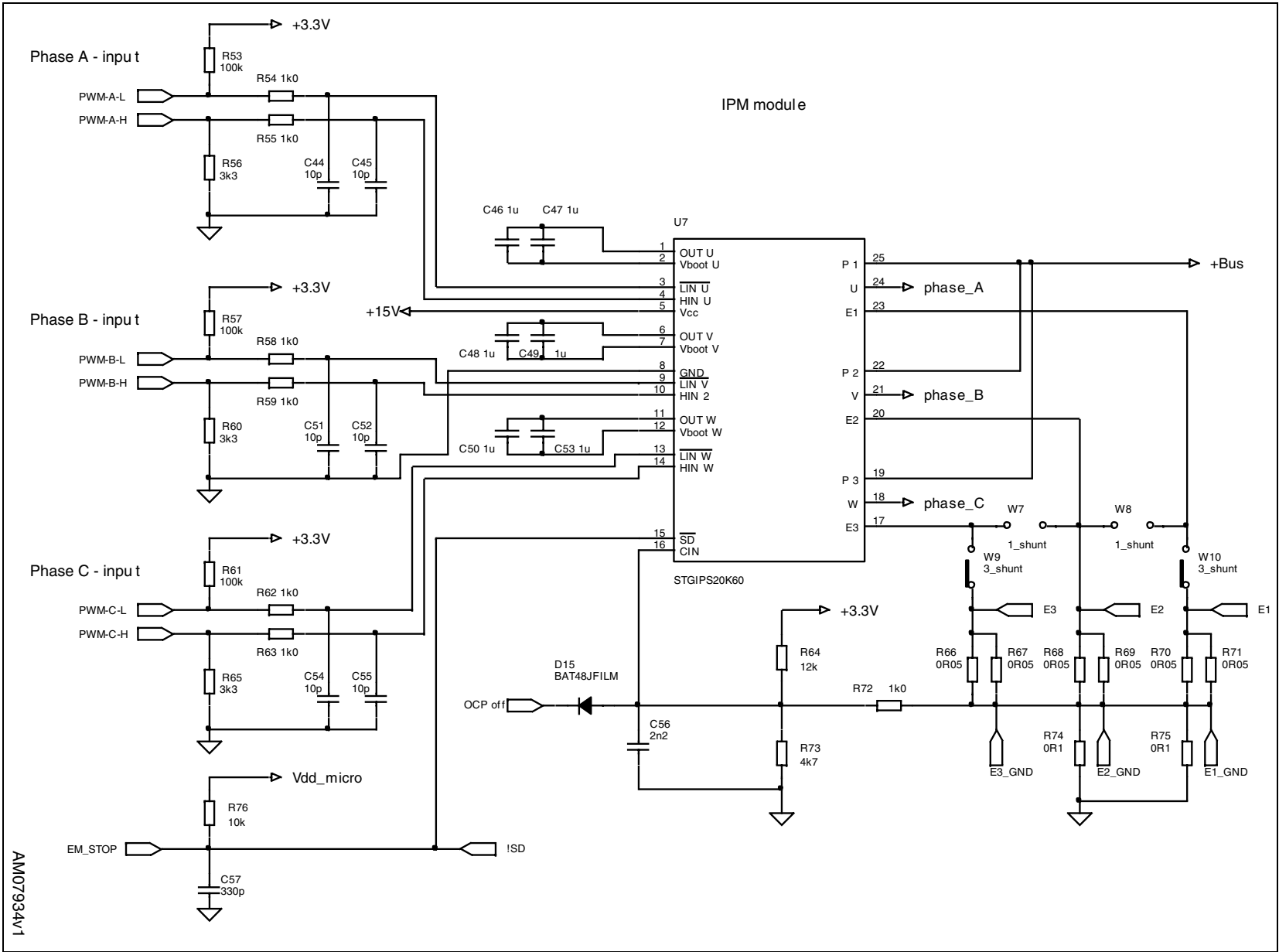

Figure 2. Schematic 2/6

Figure 3. Schematic 3/6





AM07934v1

Figure 4. Schematic 4/6

Figure 5. Schematic 5/6

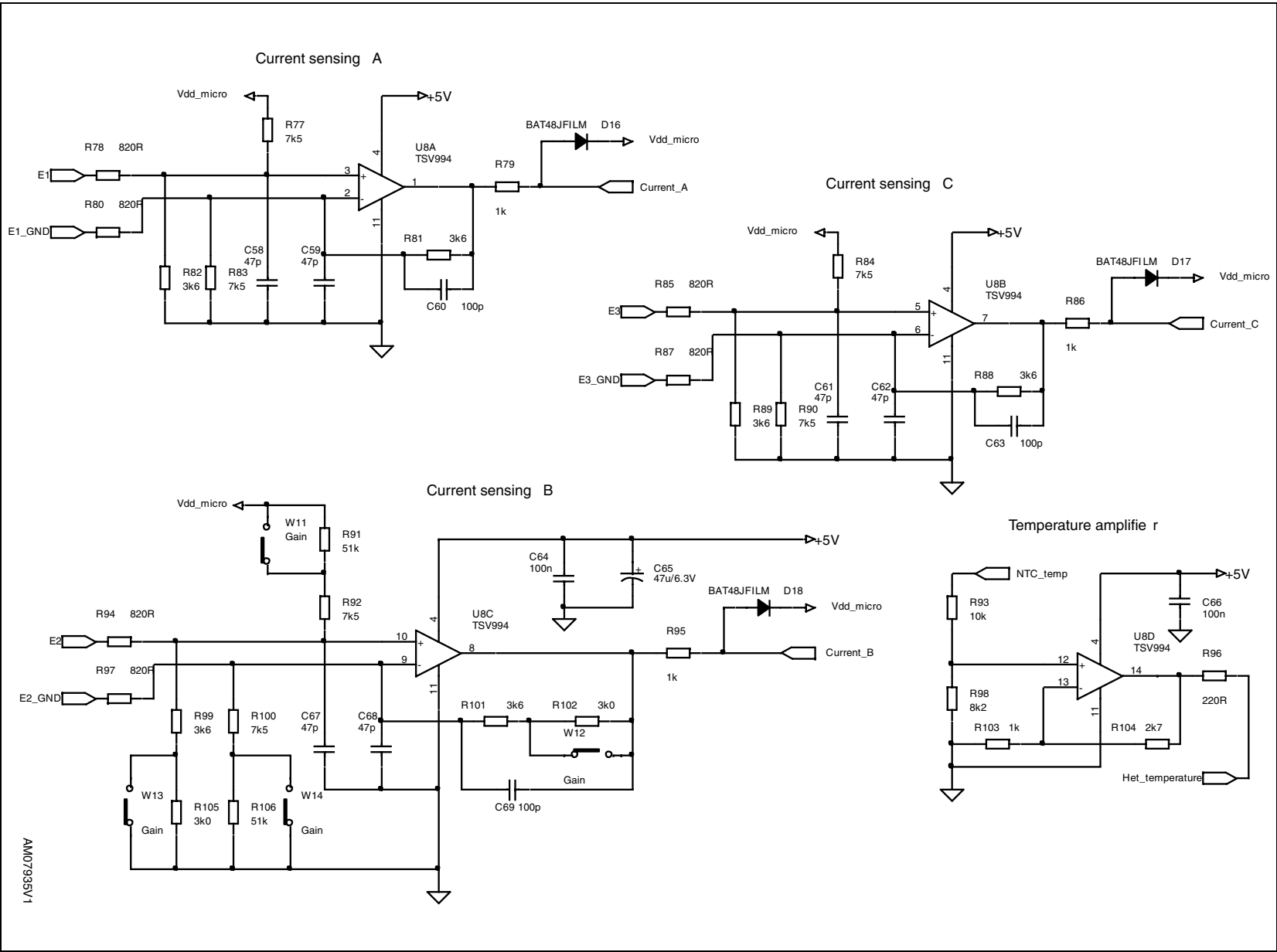

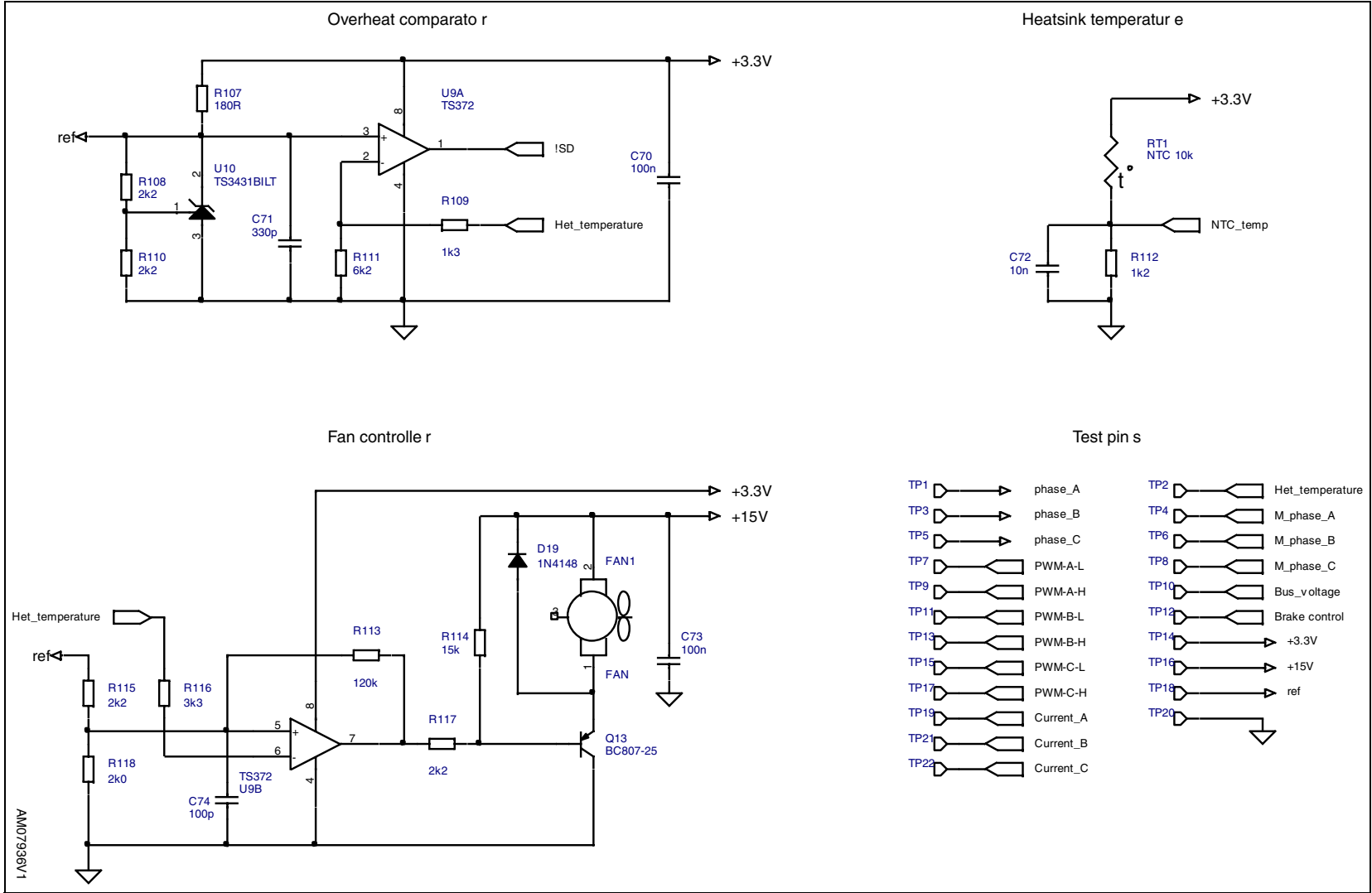

Figure 6. Schematic 6/6

2 Revision history

Table 1. Document revision history

Date	Revision	Changes
23-Feb-2011	1	Initial release.

Please Read Carefully:

Information in this document is provided solely in connection with ST products. STMicroelectronics NV and its subsidiaries ("ST") reserve the right to make changes, corrections, modifications or improvements, to this document, and the products and services described herein at any time, without notice.

All ST products are sold pursuant to ST's terms and conditions of sale.

Purchasers are solely responsible for the choice, selection and use of the ST products and services described herein, and ST assumes no liability whatsoever relating to the choice, selection or use of the ST products and services described herein.

No license, express or implied, by estoppel or otherwise, to any intellectual property rights is granted under this document. If any part of this document refers to any third party products or services it shall not be deemed a license grant by ST for the use of such third party products or services, or any intellectual property contained therein or considered as a warranty covering the use in any manner whatsoever of such third party products or services or any intellectual property contained therein.

UNLESS OTHERWISE SET FORTH IN ST'S TERMS AND CONDITIONS OF SALE ST DISCLAIMS ANY EXPRESS OR IMPLIED WARRANTY WITH RESPECT TO THE USE AND/OR SALE OF ST PRODUCTS INCLUDING WITHOUT LIMITATION IMPLIED WARRANTIES OF MERCHANTABILITY, FITNESS FOR A PARTICULAR PURPOSE (AND THEIR EQUIVALENTS UNDER THE LAWS OF ANY JURISDICTION), OR INFRINGEMENT OF ANY PATENT, COPYRIGHT OR OTHER INTELLECTUAL PROPERTY RIGHT.

UNLESS EXPRESSLY APPROVED IN WRITING BY AN AUTHORIZED ST REPRESENTATIVE, ST PRODUCTS ARE NOT RECOMMENDED, AUTHORIZED OR WARRANTED FOR USE IN MILITARY, AIR CRAFT, SPACE, LIFE SAVING, OR LIFE SUSTAINING APPLICATIONS, NOR IN PRODUCTS OR SYSTEMS WHERE FAILURE OR MALFUNCTION MAY RESULT IN PERSONAL INJURY, DEATH, OR SEVERE PROPERTY OR ENVIRONMENTAL DAMAGE. ST PRODUCTS WHICH ARE NOT SPECIFIED AS "AUTOMOTIVE GRADE" MAY ONLY BE USED IN AUTOMOTIVE APPLICATIONS AT USER'S OWN RISK.

Resale of ST products with provisions different from the statements and/or technical features set forth in this document shall immediately void any warranty granted by ST for the ST product or service described herein and shall not create or extend in any manner whatsoever, any liability of ST.

ST and the ST logo are trademarks or registered trademarks of ST in various countries.

Information in this document supersedes and replaces all information previously supplied.

The ST logo is a registered trademark of STMicroelectronics. All other names are the property of their respective owners.

© 2011 STMicroelectronics - All rights reserved

STMicroelectronics group of companies

Australia - Belgium - Brazil - Canada - China - Czech Republic - Finland - France - Germany - Hong Kong - India - Israel - Italy - Japan -
Malaysia - Malta - Morocco - Philippines - Singapore - Spain - Sweden - Switzerland - United Kingdom - United States of America

www.st.com

