

TPS92630-Q1 Three-Channel Linear LED Driver With Analog and PWM Dimming

1 Features

- Qualified for Automotive Applications
- AEC-Q100 Qualified With the Following Results:
 - Device Temperature Grade 1: -40°C to 125°C Ambient Operating Temperature Range
 - Device HBM ESD Classification Level H2
 - Device CDM ESD Classification Level C3B
- 3-Ch. LED Driver With Analog and PWM Dimming
- Wide Input-Voltage Range: 5 V–40 V
- Adjustable Constant Output Current Set by Reference Resistor
 - Max. Current: 150 mA per Channel
 - Max. Current: 450 mA in Parallel Operation Mode
 - Accuracy: $\pm 1.5\%$ per Channel When $I_{(IOUTx)} > 30\text{ mA}$
 - Accuracy: $\pm 2.5\%$ per Device When $I_{(IOUTx)} > 30\text{ mA}$
- Parallel Outputs for Higher Current Using Multiple ICs or Multiple Channels of a Single IC
- Low Dropout Voltage
 - Max. Dropout: 400 mV at 60 mA per Channel
 - Max. Dropout: 0.9 V at 150 mA per Channel
- Independent PWM Dimming per Channel
- Open and Shorted LED Detection With Deglitch Timer
- LED-String Voltage Feedback per Channel for Single-LED Short Detection
- Separate Fault Pin for Single-LED Short Failure

- Fault Pin for Open, Short, and Thermal Shutdown Failure Reporting, Allowing Parallel Bus Connection up to 15 Devices
- Device Accommodates a Slow Input-Voltage dV/dt (0.5 V/min) With No Issues
- Operating Junction Temperature Range -40°C to 150°C
- Package: 16-Pin Thermally Enhanced PWP Package (HTSSOP)

2 Applications

Automotive LED Lighting Applications, Such As:

- Daytime Running Light
- Position Light
- Fog Light
- Rear Light
- Stop or Taillight
- Interior Lighting

3 Description

The TPS92630-Q1 device is a three-channel linear LED driver with analog and PWM dimming control. Its full-diagnostic and built-in protection capabilities make it a suitable choice for variable-intensity LED lighting applications up to the medium-power range.

Device Information⁽¹⁾

PART NUMBER	PACKAGE (PIN)	BODY SIZE (NOM)
TPS92630-Q1	HTSSOP (16)	4.40 mm × 5.00 mm

(1) For all available packages, see the orderable addendum at the end of the data sheet.

4 Typical Application Schematic

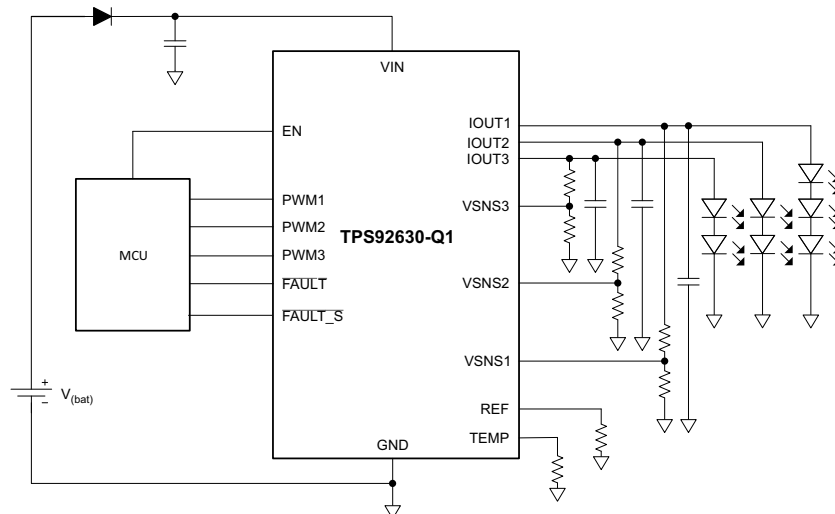

Table of Contents

1	Features	1	10.2	Functional Block Diagram	14
2	Applications	1	10.3	Feature Description	14
3	Description	1	10.4	Device Functional Modes	22
4	Typical Application Schematic	1	11	Applications and Implementation	24
5	Revision History	2	11.1	Application Information	24
6	Description (Continued)	4	11.2	Typical Applications	24
7	Pin Configuration and Functions	4	12	Power Supply Recommendations	32
8	Specifications	6	13	Layout	33
8.1	Absolute Maximum Ratings	6	13.1	Layout Guidelines	33
8.2	ESD Ratings	6	13.2	Layout Example	33
8.3	Recommended Operating Conditions	6	14	Device and Documentation Support	34
8.4	Thermal Information	6	14.1	Documentation Support	34
8.5	Electrical Characteristics	7	14.2	Receiving Notification of Documentation Updates	34
8.6	Timing Requirements	9	14.3	Community Resources	34
8.7	Typical Characteristics	10	14.4	Trademarks	34
9	Parameter Measurement Information	13	14.5	Electrostatic Discharge Caution	34
10	Detailed Description	14	14.6	Glossary	34
10.1	Overview	14	15	Mechanical, Packaging, and Orderable Information	34

5 Revision History

Changes from Revision D (January 2018) to Revision E

Page

•	Added capacitors to the outputs on the Typical Application Schematic	1
•	Changed V_{IH} and V_{IL} logic-level values for the PWMx pins	7
•	Changed parameter description for $I_{(pullup)}$ from strong to weak pullup current	8
•	Added capacitors to the outputs on Figure 26	24
•	Added the Input and Output Capacitors section	25
•	Added capacitors to the outputs on Figure 28	26
•	Added the Input and Output Capacitors section	27
•	Added capacitors to the outputs on Figure 29	28
•	Added the Input and Output Capacitors section	29
•	Added capacitors to the outputs on Figure 30	30
•	Added the Input and Output Capacitors	31
•	Added capacitors to the outputs on Figure 31	31
•	Added the Input and Output Capacitors section	32

Changes from Revision C (November 2017) to Revision D

Page

•	Changed pinout diagram	4
•	Changed text for the <i>Thermal pad</i> row in the DESCRIPTON column	5

Changes from Revision B (January 2015) to Revision C

Page

•	Deleted the TPS92630-Q1 part number from page headers	1
•	Changed TPS9263x-Q1 to TPS92630-Q1 in the data sheet title	1
•	Deleted the "Two Options" bullet from the <i>Features</i> list	1
•	Deleted the TPS92631-Q1 device from the <i>Device Information</i> table	1
•	Changed pinout diagram	4

• Deleted the COMMENT column and moved the comment text to the DESCRIPTION column.....	4
• Added a row for thermal pad information	5
• Deleted specifications pertaining to the TPS92631-Q1 device	8
• Changed figure reference in the <i>FAULT Diagnostics</i> section to Figure 19	15
• Added the Receiving Notification of Documentation Updates and Community Resources sections	34

Changes from Revision A (December 2014) to Revision B	Page
• Changed pin numbers for IOOUT1 and IOOUT3 in <i>Pin Functions</i> table	4

Changes from Original (February 2014) to Revision A	Page
• Changed pin numbers and comments in <i>Pin Functions</i> table for pins 14 and 16	4
• Changed Changed the <i>Handling Ratings</i> table to <i>ESD Ratings</i> and moved storage temperature to the <i>Absolute Maximum Ratings</i> table	6
• Changed the MAX value for the EN internal pulldown parameter from 2.5 to 5 μ A in the <i>Electrical Characteristics</i> table	7
• Added MAX value for $T_{(shutdown)}$	8
• Changed Figure 24	22
• Changed Figure 25	22
• Changed voltage on pullup resistor from 3 V to 3.3 V	22
• Changed board layout diagram	33

6 Description (Continued)

The design of this device suits it well for driving LEDs configured as a single string or multiple strings within its power capability. A single device can drive up to three strings with one to three LEDs in each string at a total current of up to 150 mA per channel. Outputs can be paralleled to provide higher current drive capability to 450 mA.

In multiple-string applications, the device offers the advantage of having common-cathode connection of the LED strings. So, the application needs only a single return wire instead of one return wire per LED string that a system with low-side current sense would need.

A single-LED-short comparator allows detection of single LED failing with a short circuit. Fault output can support bus connection topology between multiple devices.

The included temperature monitor reduces the LED drive current if the device junction temperature exceeds a thermal threshold. One can program the temperature threshold through an external resistor. One can disable the thermal current-monitor feature by connecting the TEMP pin to ground. Output of the junction temperature as an analog voltage is available as a factory program option.

7 Pin Configuration and Functions

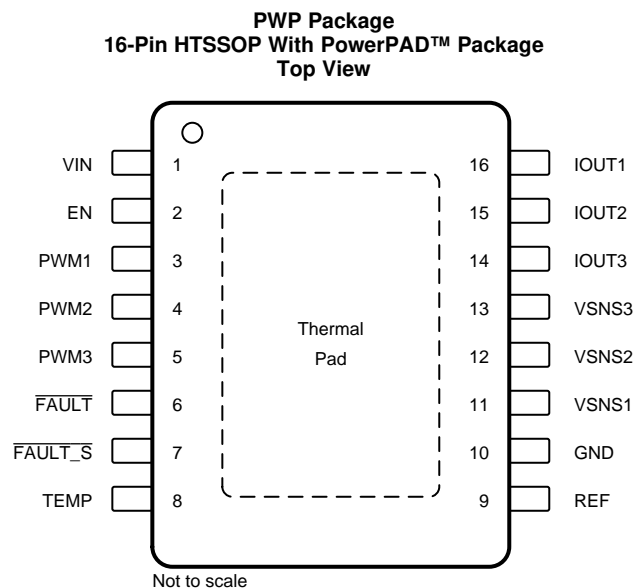

Pin Functions

PIN		I/O	DESCRIPTION
NAME	NO.		
EN	2	I	Enable and shut down
$\overline{\text{FAULT}}$	6	I/O	Fault pin. Leave floating if not used.
$\overline{\text{FAULT_S}}$	7	I/O	Single-LED short fault. Leave floating if not used.
GND	10	—	Ground
IOUT1	16	O	Current output pin. Connect to VSNS1 if not used.
IOUT2	15	O	Current output pin. Connect to VSNS2 if not used.
IOUT3	14	O	Current output pin. Connect to VSNS3 if not used.
PWM1	3	I	PWM input and channel ON or OFF. Tie to GND if this channel is not used.
PWM2	4	I	PWM input and channel ON or OFF. Tie to GND if this channel is not used.
PWM3	5	I	PWM input and channel ON or OFF. Tie to GND if this channel is not used.
REF	9	O	Reference resistor pin for normal current setting
TEMP	8	I/O	Temperature foldback threshold program. Tie to GND if not used.

Pin Functions (continued)

PIN		I/O	DESCRIPTION
NAME	NO.		
VIN	1	—	Input pin – VBAT supply
VSNS1	11	I	String voltage sense. Connect to IOOUT1 if not used.
VSNS2	12	I	String voltage sense. Connect to IOOUT2 if not used.
VSNS3	13	I	String voltage sense. Connect to IOOUT3 if not used.
Thermal pad	—	—	Connect to GND

8 Specifications

8.1 Absolute Maximum Ratings⁽¹⁾

		MIN	MAX	UNIT
V _{IN} , I _{OUTx} , PWM _x , EN, VSNS _x	Unregulated input ^{(2) (3) (4)}	-0.3	45	V
$\overline{\text{FAULT}}$, $\overline{\text{FAULT_S}}$	See ⁽²⁾	-0.3	22	V
Others	See ⁽²⁾	-0.3	7	V
Virtual junction temperature, T _J		-40	150	°C
Operating ambient temperature, T _A		-40	125	°C
Storage temperature, T _{stg}		-65	150	°C

- (1) Stresses beyond those listed under *Absolute Maximum Ratings* may cause permanent damage to the device. These are stress ratings only, and functional operation of the device at these or any other conditions beyond those indicated under *Recommended Operating Conditions* is not implied. Exposure to absolute-maximum-rated conditions for extended periods may affect device reliability.
- (2) All voltage values are with respect to GND.
- (3) Absolute maximum voltage 45 V for 200 ms
- (4) V_{IOUTx} must be less than V_{VIN} + 0.3 V

8.2 ESD Ratings

			VALUE	UNIT
V _(ESD)	Human-body model (HBM), per ANSI/ESDA/JEDEC JS-001, all pins ⁽¹⁾		±2000	V
	Charged-device model (CDM), per AEC Q100-011	Corner pins (1, 8, 9, and 16)	±750	
		Other pins	±500	

- (1) AEC Q100-002 indicates HBM stressing is done in accordance with the ANSI/ESDA/JEDEC JS-001 specification.

8.3 Recommended Operating Conditions

		MIN	MAX	UNIT
V _{IN}		5	40	V
PWM _x , EN, VSNS _x		0	40	V
$\overline{\text{FAULT}}$, $\overline{\text{FAULT_S}}$		0	20	V
Others		0	5	V
T _J	Operating junction temperature range	-40	150	°C

8.4 Thermal Information

THERMAL METRIC ⁽¹⁾		TPS92630-Q1	UNIT
		PWP (HTSSOP)	
		16 PINS	
R _{θJA}	Junction-to-ambient thermal resistance ⁽²⁾	41.5	°C/W
R _{θJC(top)}	Junction-to-case (top) thermal resistance	29.6	°C/W
R _{θJB}	Junction-to-board thermal resistance	24	°C/W
ψ _{JT}	Junction-to-top characterization parameter	1	°C/W
ψ _{JB}	Junction-to-board characterization parameter	23.8	°C/W
R _{θJC(bot)}	Junction-to-case (bottom) thermal resistance	3.4	°C/W

- (1) For more information about traditional and new thermal metrics, see [Semiconductor and IC Package Thermal Metrics](#).
- (2) The thermal data is based on JEDEC standard high-K profile – JESD 51-7. The copper pad is soldered to the thermal land pattern. Also, correct attachment procedure must be incorporated.

8.5 Electrical Characteristics

 $V_{(VIN)} = 14\text{ V}$, $T_J = -40^\circ\text{C}$ to 150°C (unless otherwise stated)

PARAMETER		TEST CONDITIONS	MIN	TYP	MAX	UNIT
SUPPLY VOLTAGE AND CURRENT (VIN)						
V_I	Input voltage		5		40	V
$I_{(quiescent)}$	Quiescent current	All PWMx = high, $I_{(IOUTx)} = 100\text{ mA}$, Not including I_{ref}	0.5	0.6	0.85	mA
$I_{O(sd)}$	Shutdown current	$V_{(EN)} = 0\text{ V}$			10	μA
$I_{(fault)}$	Shutdown current in fault mode (device to GND)	PWM = EN = high, $\overline{\text{FAULT}} = \text{low}$, $V_{(VIN)} = 5\text{ V}$ – 40 V , $I = 100\text{ mA}$	0.5	0.6	0.85	mA
	Shutdown current in fault mode (from $V_{(VIN)}$)	PWM = EN = high, $\overline{\text{FAULT}} = \text{low}$, $V_{(VIN)} = 5\text{ V}$ – 40 V , $I = 100\text{ mA}$			2	
PWMx AND EN						
$V_{IL(EN)}$	Logic input, low level	IOUTx disabled	0		0.7	V
$V_{IH(EN)}$	Logic input, high level	IOUTx enabled	2			V
$I_{(EN-pd)}$	EN internal pulldown	$V_{(EN)} = 0\text{ V}$ to 40 V	0.35		5	μA
$V_{IL(PWMx)}$	Logic input, low level	IOUTx disabled	1.135	1.195	1.255	V
$V_{IH(PWMx)}$	Logic input, high level	IOUTx enabled	1.161	1.222	1.283	V
$V_{hys(PWM)}$	Hysteresis			44		mV
$I_{(PWM-pd)}$	PWMx internal pulldown current	$V_{(PWMx)} = 40\text{ V}$	100	180	250	nA
CURRENT REGULATION (IOUTx)						
$I_{(IOUTx)}$	Regulated output current range	Each channel	10		150	mA
		Three channels in parallel mode	30		450	
$\Delta I_{O(channel)}$	Channel accuracy	$10\text{ mA} < I_{(IOUTx)} < 30\text{ mA}$, $V_{(VIN)} = 5\text{ V}$ – 40 V Channel accuracy = $\frac{I_{(IOUTx)} - I_{(avg)}}{I_{(avg)}}$ (1)	-3%		3%	
		$30\text{ mA} \leq I_{(IOUTx)} < 150\text{ mA}$, $V_{in} = 5\text{ V}$ – 40 V Channel accuracy = $\frac{I_{(IOUTx)} - I_{(avg)}}{I_{(avg)}}$ (1)	-1.5%		1.5%	
$\Delta I_{O(device)}$	Device accuracy	$10\text{ mA} < I_{(IOUTx)} < 30\text{ mA}$, $V_{(VIN)} = 5\text{ V}$ to 20 V (2) Device accuracy = $\frac{I_{(IOUTx)} - I_{(setting)}}{I_{(setting)}}$ (3)	-4%		4%	
		$30\text{ mA} \leq I_{OUT} < 150\text{ mA}$, $V_{(VIN)} = 5\text{ V}$ to 20 V (2) Device accuracy = $\frac{I_{(IOUTx)} - I_{(setting)}}{I_{(setting)}}$ (3)	-2.5%		2.5%	
V_{ref}	Reference voltage		1.198	1.222	1.246	V
$K_{(I)}$	Ratio of $I_{(IOUTx)}$ to reference current			100		
$V_{(DROD)}$	Dropout voltage	At 150 mA load per channel		0.6	0.9	V
		At 60 mA load per channel		0.24	0.4	
SR	Current rise and fall slew rates	Current rising from 10% to 90% or falling from 90% to 10% at $I_{(IOUTx)} = 60\text{ mA}$.(4)	4	8	15	mA/ μs
		Current rising from 10% to 90% or falling from 90% to 10% at $I_{(IOUTx)} = 150\text{ mA}$.(4)	7	14	25	mA/ μs

(1) $I_{(AVG)} = [I_{(IOUT1)} + I_{(IOUT2)} + I_{(IOUT3)}] / 3$

(2) For $V_{(VIN)}$ voltages higher than 20 V, see Figure 2 and Figure 3.

(3) $I_{(setting)}$ is the target current set by R_{ref} .

(4) See Figure 17 for the load model for the slew-rate test and delay-time test.

Electrical Characteristics (continued)
 $V_{(VIN)} = 14\text{ V}$, $T_J = -40^\circ\text{C}$ to 150°C (unless otherwise stated)

PARAMETER		TEST CONDITIONS	MIN	TYP	MAX	UNIT
FAULT (FAULT)						
V_{IL}	Logic input low threshold				0.7	V
V_{IH}	Logic input high threshold		2			V
V_{OL}	Logic output low level	Tested with 500- μA external pullup			0.7	V
V_{OH}	Logic output high level	Tested with 1- μA external pulldown	2			V
$I_{(pulldown)}$	Strong pulldown current		500	750	1000	μA
$I_{(pullup)}$	Weak pullup current		4	8	16	μA
COMPARATOR (VSNSx)						
$V_{(VSNSx)}$	Internal comparator reference (for short circuit detection)	$V_{(VIN)} > V_{(th)}$	1.198	1.222	1.246	V
I_{lkq}	Leakage current	$V_{(VSNSx)} = 3\text{ V}$			500	nA
$V_{(th)}$	Voltage at which the chip enables the single-short alarm function	Single-short detection enabled	8		9	V
	$V_{(th)}$ hysteresis			145		mV
PROTECTION						
$V_{(OLV)}$	Open-load detection voltage	$V_{(OLV)} = V_{(VIN)} - V_{(IOUTx)}$	50	100	150	mV
$V_{(OL-hys)}$	Open-load detection hysteresis		100	200	300	mV
$V_{(SV)}$	Short-detection voltage		0.846	0.89	0.935	V
	Short-detection hysteresis		318	335	352	mV
	Short-detection deglitch		1	2	3	ms
		During PWM, count the number of continuous cycles when $V_{(IOUTx)} < V_{(SV)}$	7		8	Cycles
$R_{(REF_open)}$	REF pin resistor open detection	$\overline{\text{FAULT}}$ goes low	15	23	57	$\text{k}\Omega$
$R_{(REF_short)}$	REF pin resistor short detection	$\overline{\text{FAULT}}$ goes low	350	470	800	Ω
THERMAL MONITOR						
$T_{(shutdown)}$	Thermal shutdown		155	170	170	$^\circ\text{C}$
$T_{(hys)}$	Thermal shutdown hysteresis			15		$^\circ\text{C}$
$T_{(th)}$	Thermal foldback activation temperature	90% of $I_{(IOUTx)}$ normal (TEMP pin floating)	95	110	125	$^\circ\text{C}$
$I_{(TFCmin)}$	Minimum foldback current		40%	50%	60%	
$V_{(T-disable)}$	Thermal-foldback-function disable voltage			0	0.2	V

8.6 Timing Requirements

			MIN	NOM	MAX	UNIT
$t_{\text{(startup)}}$	Start-up time	$V_{\text{(VIN)}} > 5 \text{ V}$, $I_{\text{(IOUTx)}} = 50\%$, $I_{\text{(setting)}} = 60 \text{ mA}$ ⁽¹⁾			200	μs
$t_{\text{d(on)}}$	Delay time between PWM rising edge to 10% of $I_{\text{(IOUTx)}}$	Two LEDs in series, 10-k Ω resistor in parallel		14	30	μs
$t_{\text{d(off)}}$	Delay time between PWM falling edge to 90% of $I_{\text{(IOUTx)}}$	Two LEDs in series, 10-k Ω resistor in parallel		25	45	μs
	Single-short detection deglitch		1	2	3	ms
		During PWM, count the number of continuous cycles when $V_{\text{(VNSx)}} < 1.24 \text{ V}$	7		8	Cycles
	Open-load detection deglitch		1	2	3	ms
		During PWM, count the number of continuous cycles when $V_{\text{(VIN)}} - V_{\text{(IOUTx)}} < V_{\text{(OLV)}}$	7		8	Cycles
	Short-detection deglitch		1	2	3	ms
		During PWM, count the number of continuous cycles when $V_{\text{(IOUTx)}} < V_{\text{(SV)}}$	7		8	Cycles

(1) Start-up is considered complete when $I_{\text{(setting)}}$ increases to 30 mA.

8.7 Typical Characteristics

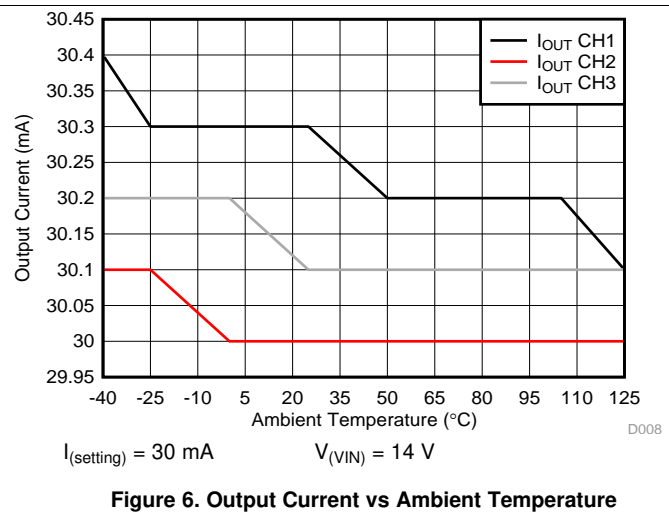
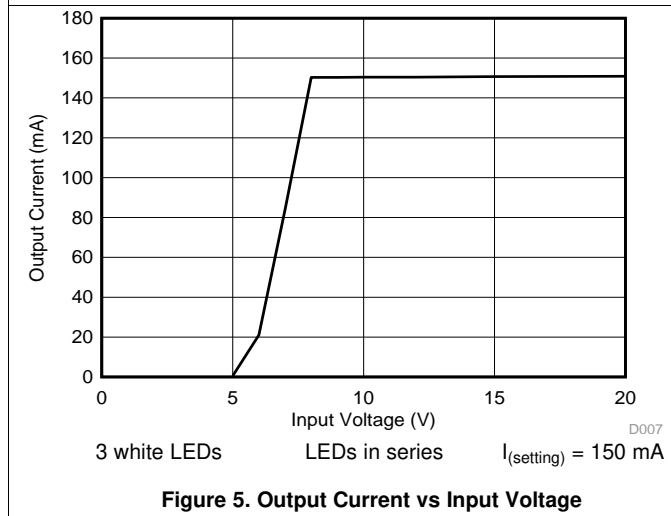
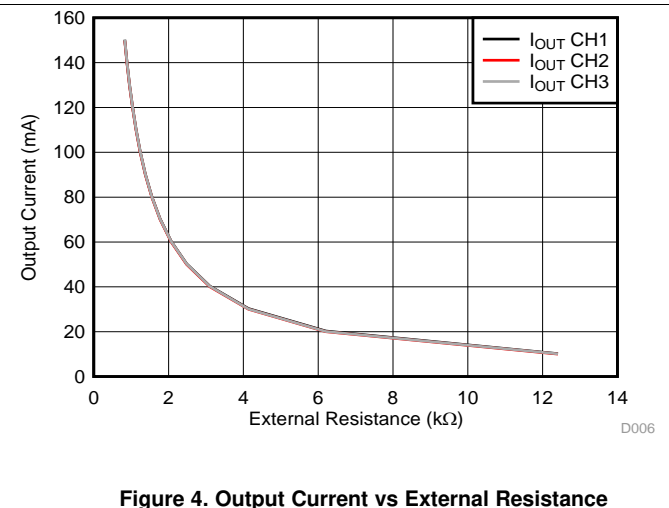
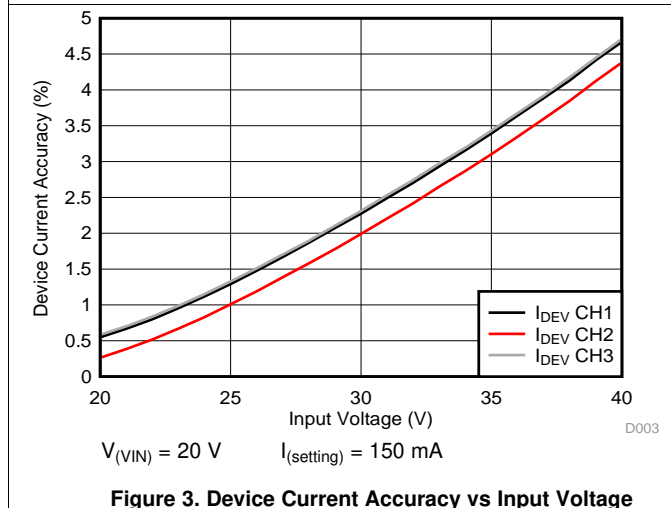
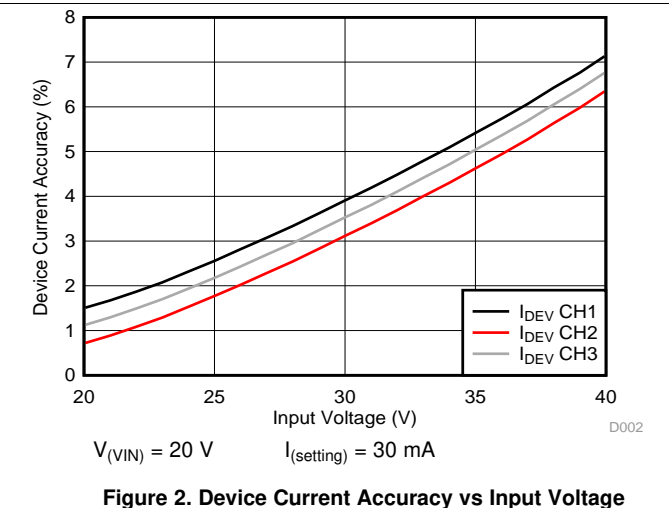
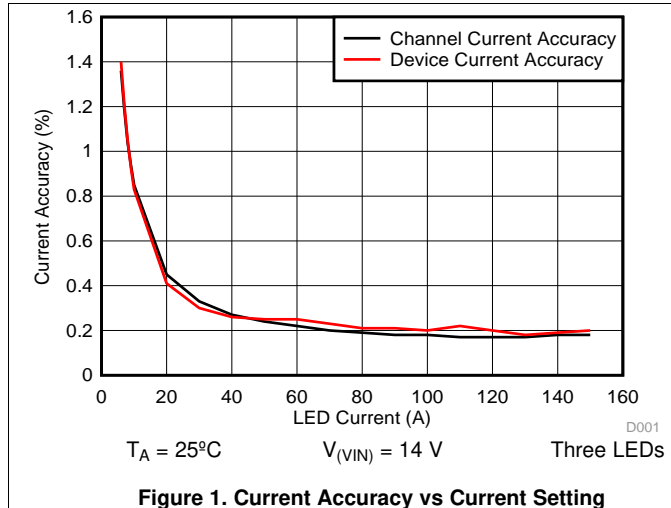

Typical Characteristics (continued)

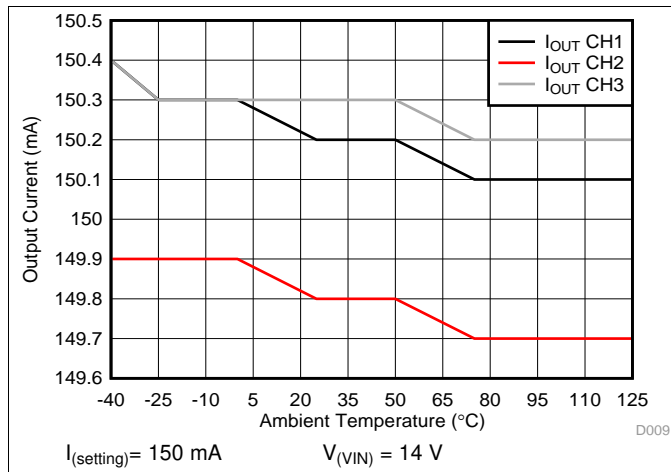

Figure 7. Output Current vs Ambient Temperature

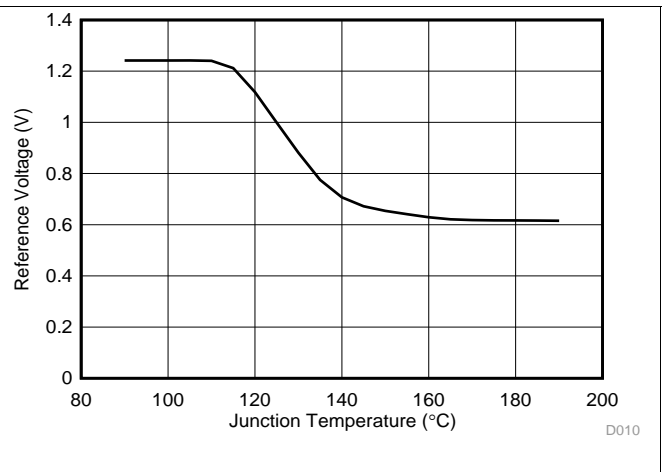

Figure 8. Reference Voltage vs Junction Temperature With Thermal Foldback

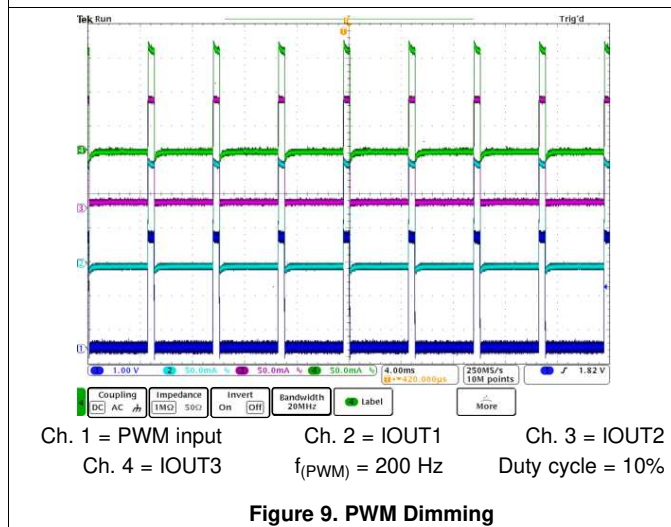

Figure 9. PWM Dimming

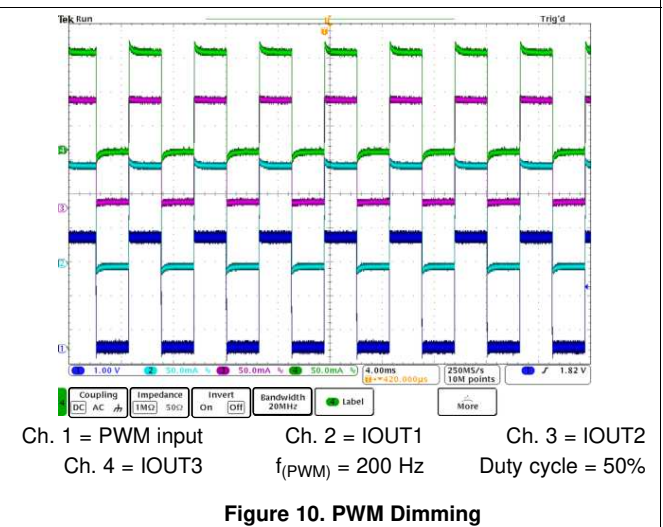

Figure 10. PWM Dimming

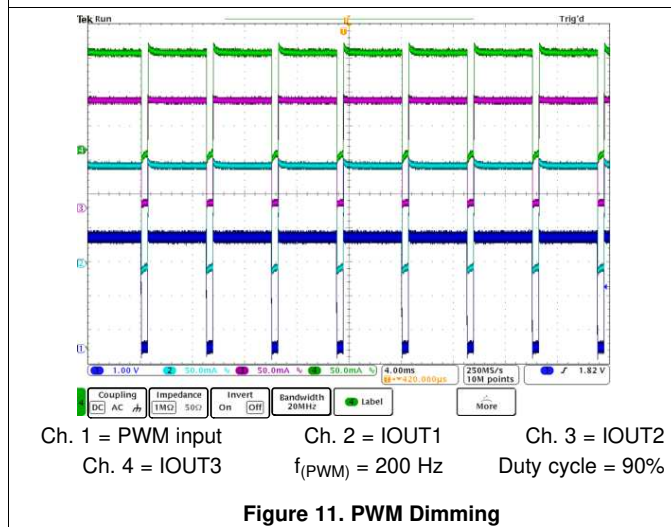

Figure 11. PWM Dimming

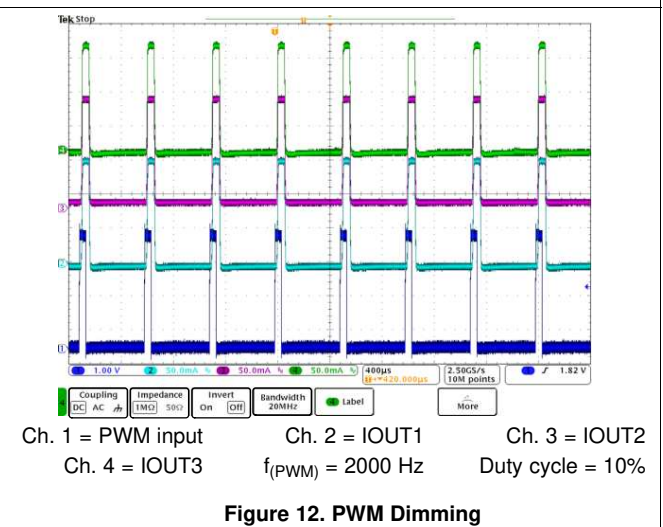

Figure 12. PWM Dimming

Typical Characteristics (continued)

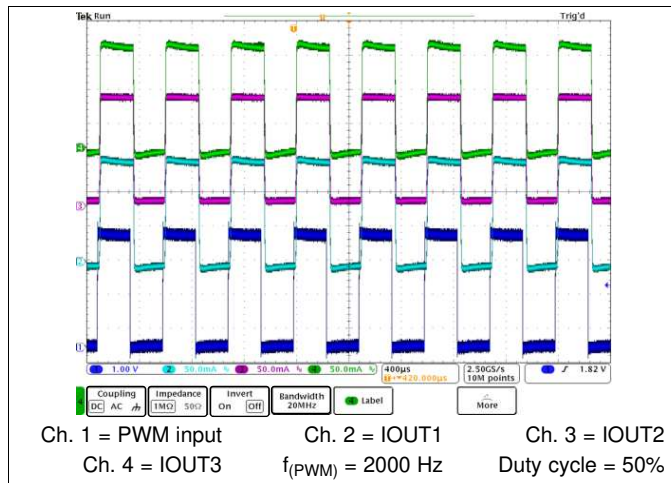

Figure 13. PWM Dimming

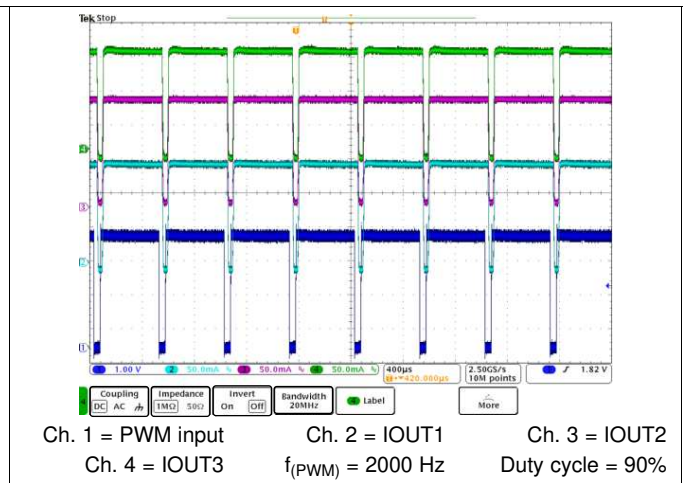
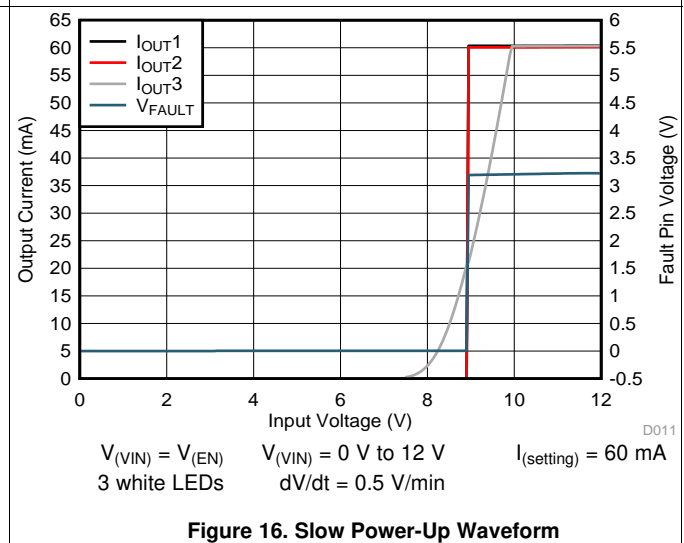
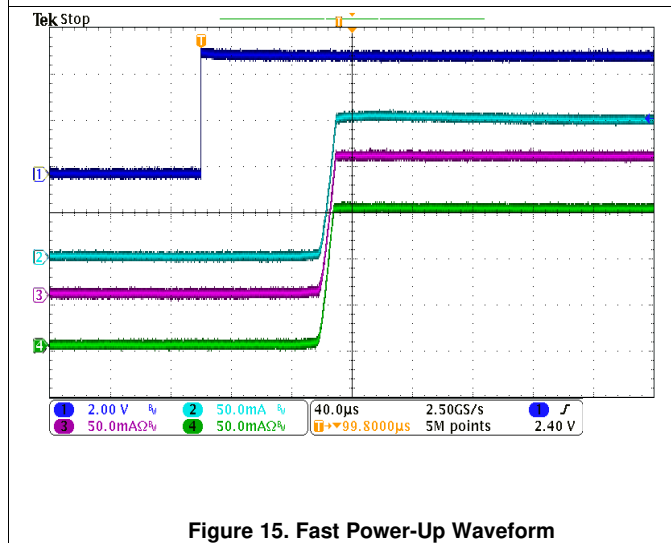

Figure 14. PWM Dimming



9 Parameter Measurement Information

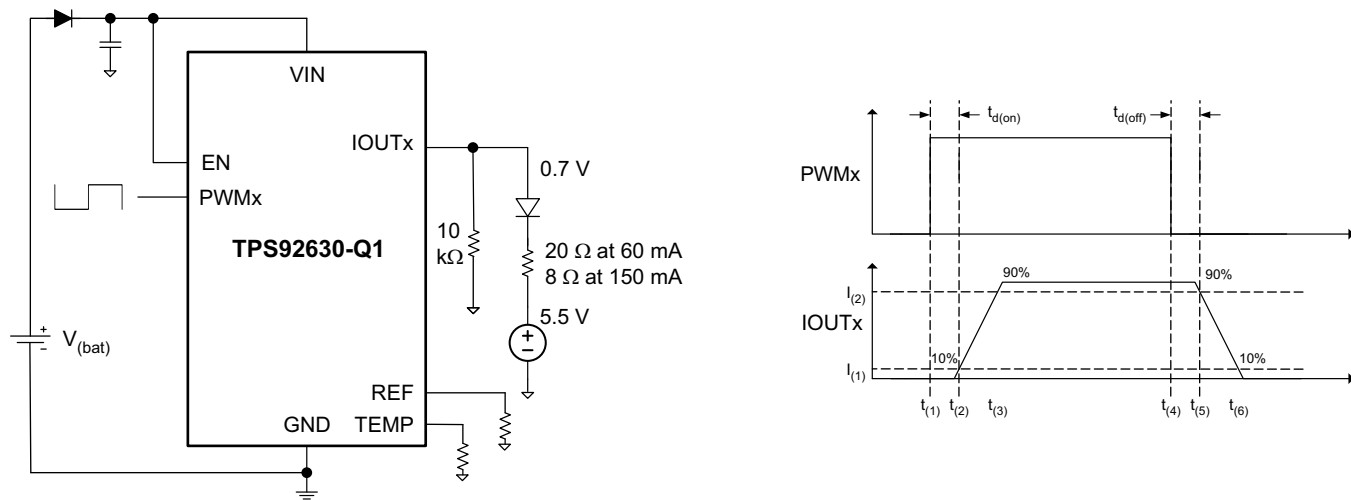

Figure 17. Load Model for Slew-Rate and Delay-Time Tests

10 Detailed Description

10.1 Overview

The TPS92630-Q1 device is a three-channel constant-current regulator with individual PWM dimming, designed for high brightness red or white LEDs in automotive lighting applications. Each channel has up to 150-mA current capability, giving a combined 450-mA current capability when paralleled. The device provides excellent current matching between channels and devices. A high-side current source allows LED common-cathode connections. The advanced control loop allows high accuracy between channels, even when different numbers of LEDs are connected on the output. Use of a separate PWM channel dims or disables each channel.

The TPS92630-Q1 device monitors fault conditions on the output and reports its status on the $\overline{\text{FAULT}}$ and $\overline{\text{FAULT_S}}$ pins. It features single-short-LED detection, output short-to-ground detection, open-load detection, and thermal shutdown. Two separate fault pins allow maximum flexibility of fault-mode reporting to the MCU in case of an error. In case there is no MCU, one can connect multiple TPS92630-Q1 devices in a bus mode.

Integrated thermal foldback protects the devices from thermal shutdown by reducing the output current linearly when reaching a preset threshold. Use an external resistor to program the temperature foldback threshold. Tying the TEMP pin to ground disables this function.

10.2 Functional Block Diagram

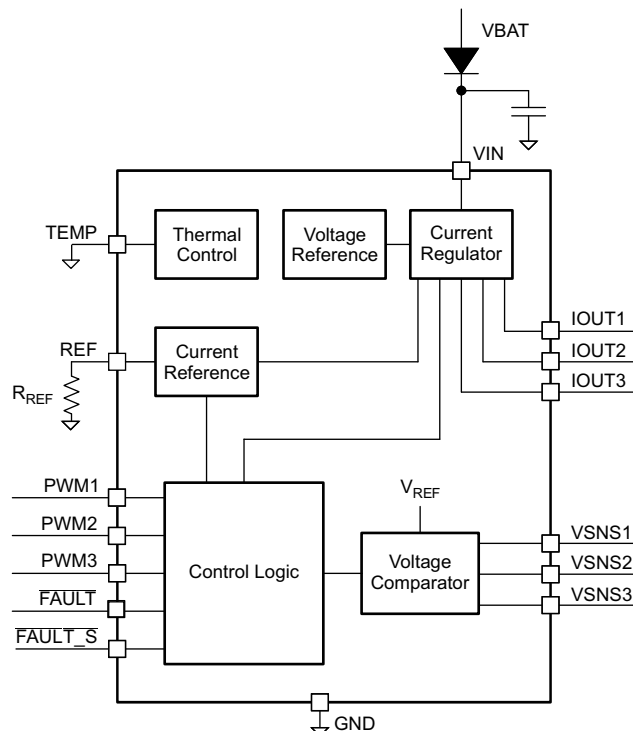

10.3 Feature Description

10.3.1 Constant LED-Current Setting

Control of the three LED output channels is through separate linear current regulators. A common external resistor sets the current in each channel. The device also features two current levels with external circuitry, intended for stop- and tail-light applications.

See [Equation 1](#) on how to set the current:

Feature Description (continued)

$$\begin{aligned}
 I_{(IOUTx)} &= \frac{V_{ref} \times K_{(I)}}{R_{(REF)}} \\
 R_{(REF)} &= \frac{V_{ref} \times K_{(I)}}{I_{(IOUTx)}}
 \end{aligned}
 \tag{1}$$

10.3.2 PWM Control

The device features a separate PWM dimming control pin for each output channel. PWM inputs also function as shutdown pin when an output is unused. Tying PWM to ground disables the corresponding output. The PWM signal has a precise threshold, which one can use to define the start-up voltage of LED as an undervoltage-lockout (UVLO) function with the divider resistor from the VIN pin.

10.3.3 $\overline{\text{FAULT}}$ Diagnostics

The TPS92630-Q1 device has two fault pins, $\overline{\text{FAULT}}$ and $\overline{\text{FAULT_S}}$. $\overline{\text{FAULT_S}}$ is a dedicated fault pin for single-LED short failure and $\overline{\text{FAULT}}$ is for general faults, that is, short, open, and thermal shutdown. The dual pins allow maximum flexibility based on all requirements and application conditions.

The device fault pins can be connected to an MCU for fault reporting. Both fault pins are open-drain transistors with a weak internal pullup. See [Figure 19](#).

Feature Description (continued)

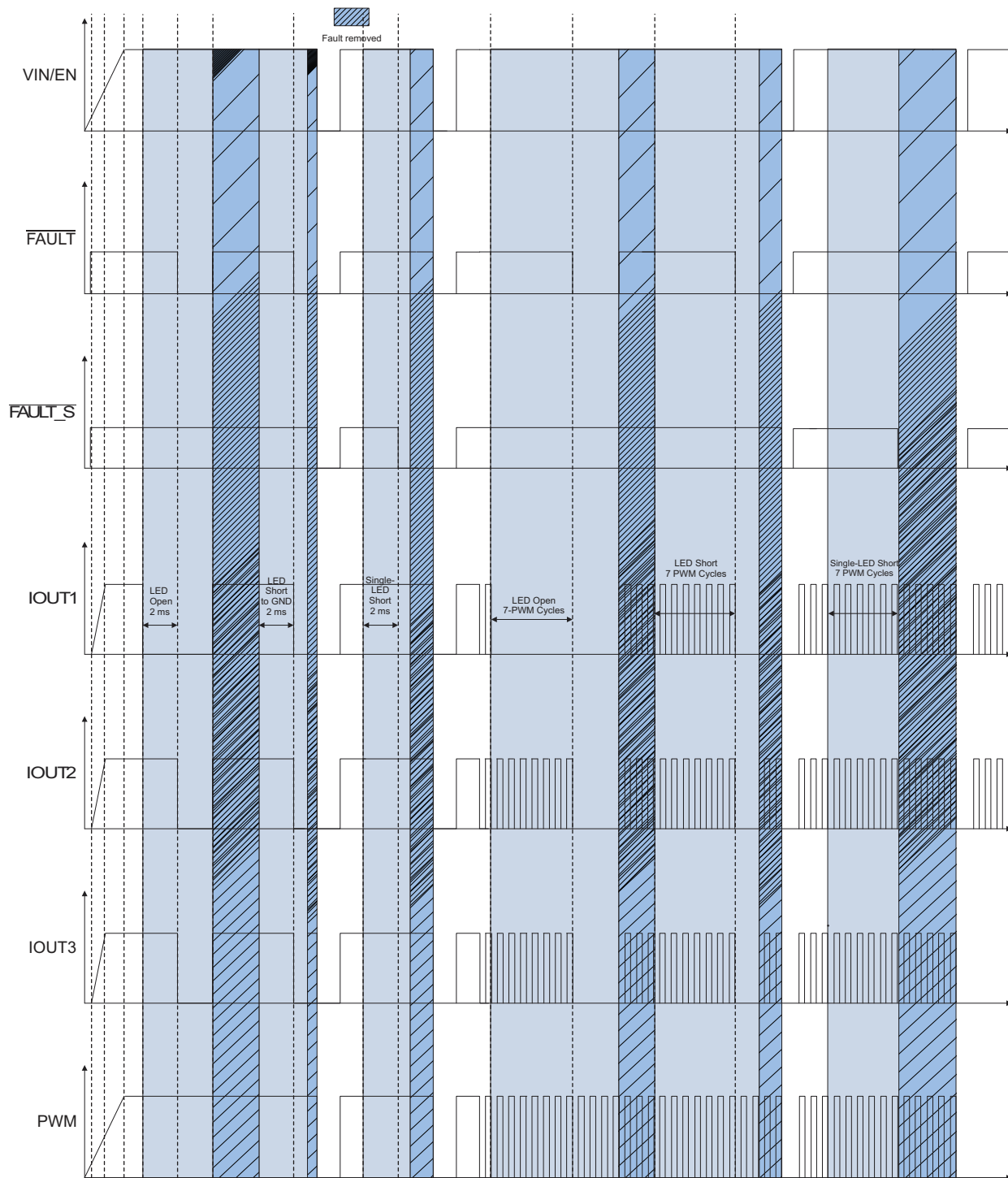

Figure 18. Detailed Timing Diagram

In case there is no MCU, one can connect up to 15 TPS92630-Q1 $\overline{\text{FAULT}}$ and $\overline{\text{FAULT_S}}$ pins together. When one or more devices have errors, the respective $\overline{\text{FAULT}}$ pins go low, pulling the connected $\overline{\text{FAULT}}$ bus down and shutting down all device outputs. Figure 19 shows the fault-line bus connection.

Feature Description (continued)

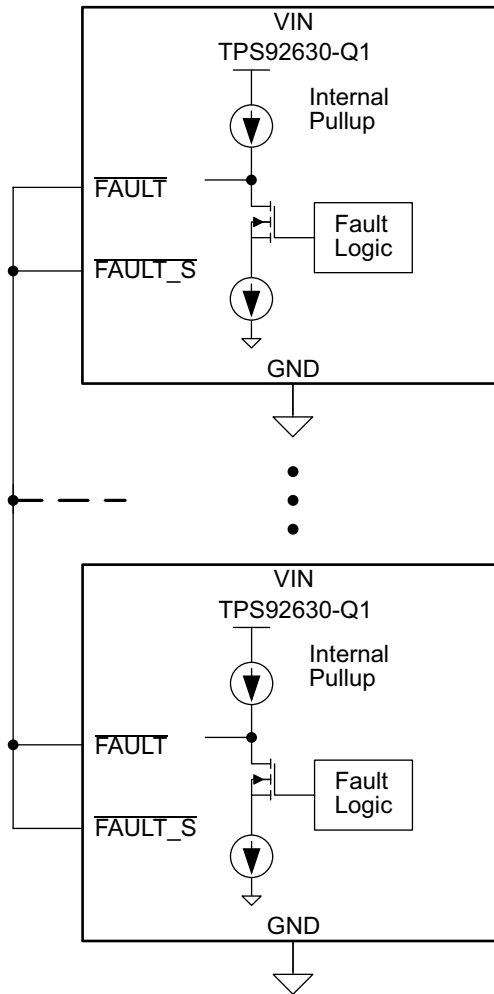
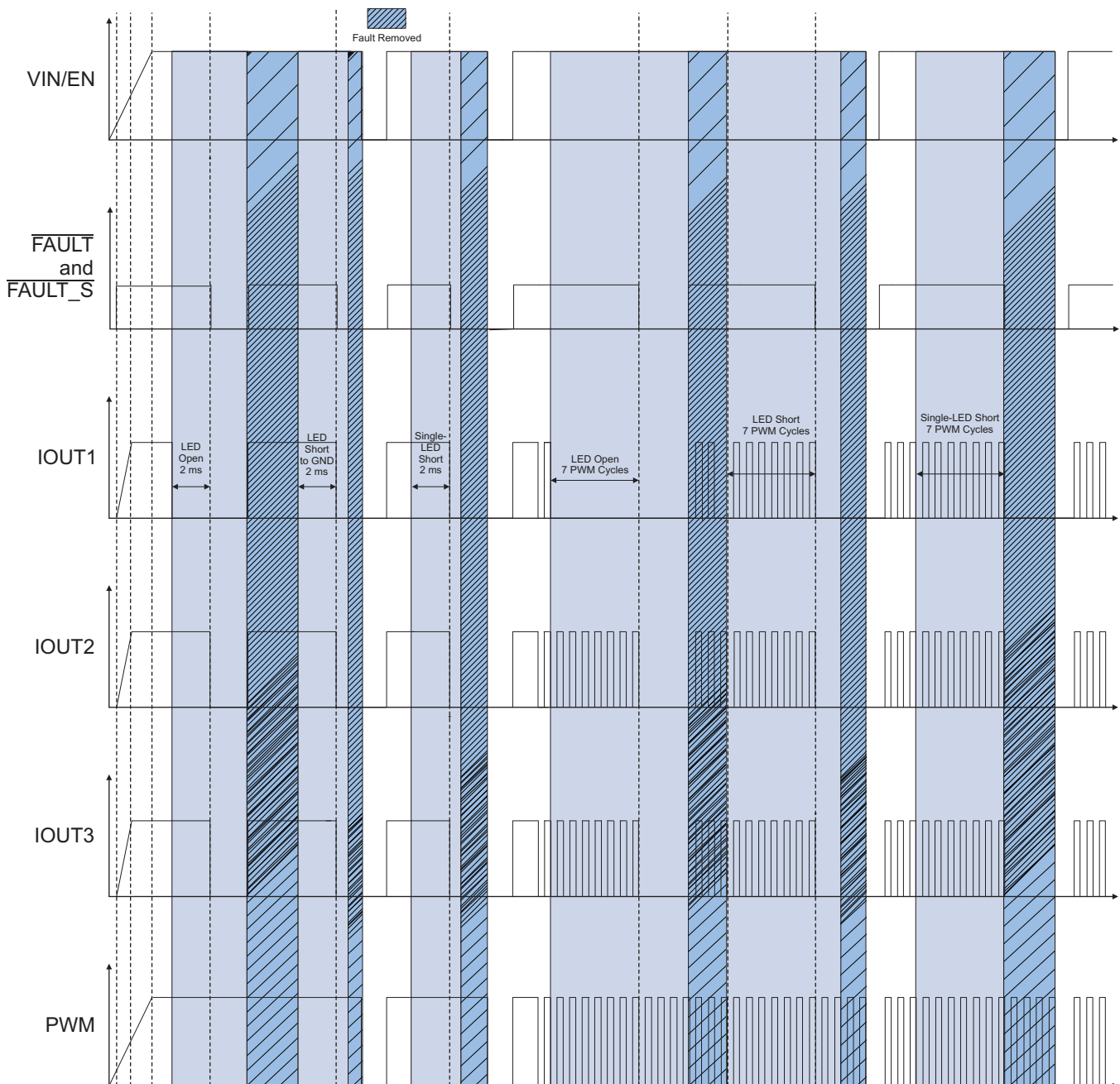

Figure 19. Fault-Line Bus Connection

The device releases the FAULT bus when external circuitry pulls the $\overline{\text{FAULT}}$ pin high, on toggling of the EN pin, or on a power cycle of the device. In case there is no MCU, only a power cycle clears the fault. See [Figure 20](#).

Feature Description (continued)

Figure 20. Detailed Timing Diagram

The following faults result in the $\overline{\text{FAULT}}$ or $\overline{\text{FAULT_S}}$ pin going low: thermal shutdown, open load, output short circuit, single LED short, and REF open or shorted. For thermal shutdown or LED open, release of the $\overline{\text{FAULT}}$ pin occurs when the thermal-shutdown or LED-open condition no longer exists. For other faults, the $\overline{\text{FAULT}}$ and $\overline{\text{FAULT_S}}$ pins stay low even if the condition does not exist. Clearing the faults requires a power cycle of the device.

Feature Description (continued)

10.3.4 Short-Circuit Detection

The device includes three internal comparators for LED forward-voltage measurement. With external resistor dividers, the device compares total LED forward voltage with the internal reference voltage. This feature enables the detection of one or more shorted LEDs. Any LED cathode or IOUTx pin shorted to ground results in a short-circuit condition. The external resistor dividers control the detection-threshold-voltage setting.

Figure 21 illustrates different short-circuit conditions.

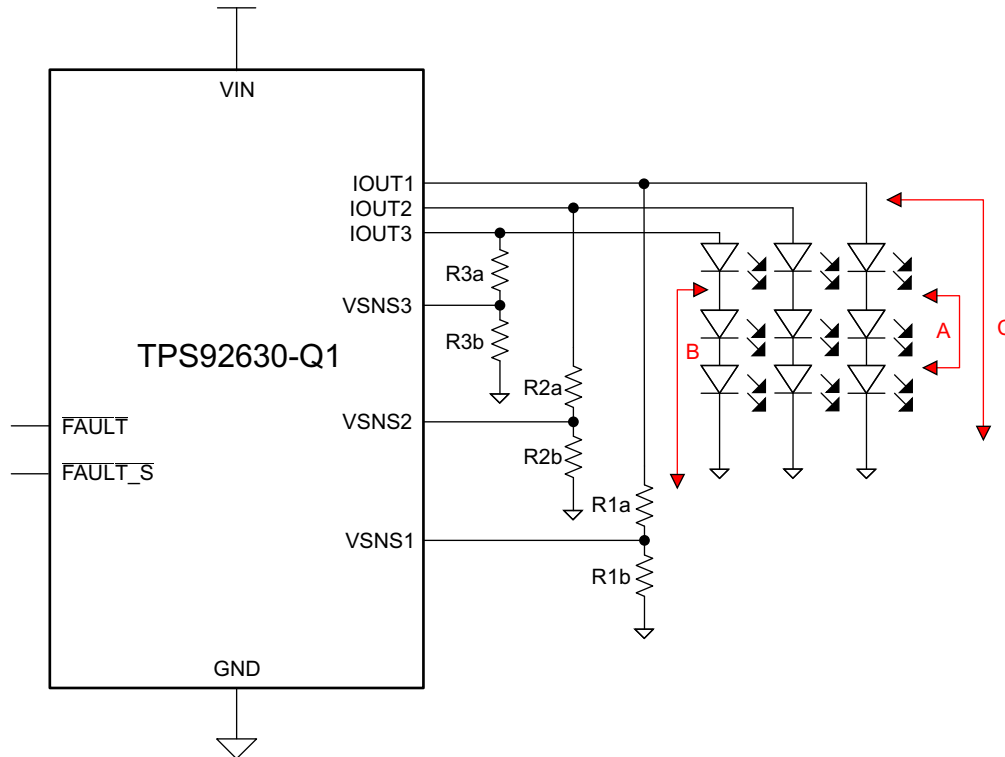

Figure 21. Short-Circuit Conditions

A short in one or more LEDs in a string (A and B as illustrated) registers as only a single-LED short when $V_{(VIN)} > 9\text{ V}$.

- The device reports the failure to the MCU. The faulted channel continues sourcing current until the MCU takes actions to turn off channels through the EN or PWMx pin.
- No MCU: with $\overline{\text{FAULT_S}}$ floating, no action results. With $\overline{\text{FAULT_S}}$ tied to $\overline{\text{FAULT}}$, all output channels shut down together.

When an entire string of LEDs is shorted (C as illustrated), the device pulls $\overline{\text{FAULT}}$ low to shut down all channels. With the $\overline{\text{FAULT}}$ pin tied high, only the faulted channel turns off.

- $V_{F(\text{max})}$ – maximum forward voltage of LED used
- $V_{F(\text{min})}$ – minimum forward voltage of LED used
- N – Number of LEDs used in a string
- R – resistor divider ratio
- $V_{(VSNSx)}$ – internal reference voltage of comparators

When selecting R, observe the following relationship to avoid false triggering.

$$R = (R_{xa} + R_{xb}) / R_{xb} \quad (2)$$

$$(N - 1) \times V_{F(\text{max})} < V_{(VSNSx)} \times R < N \times V_{F(\text{min})} \quad (3)$$

Feature Description (continued)

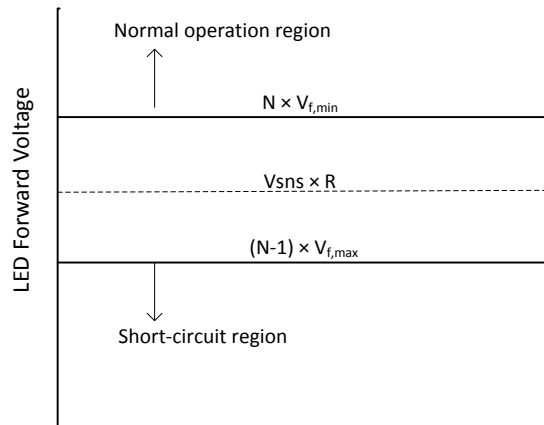

Figure 22. Single-LED Short-Trigger Calculation

10.3.5 Open-Load Detection

Detection of an open-load condition occurs when the voltage across the channel, $V_{(VIN)} - V_{(IOUTx)}$, is less than the open-load detection voltage, $V_{(OLV)}$. When this condition is present for more than the open-load-detection deglitch (2 ms when PWM is 100% on or one PWM on-time is more than 2 ms, or seven continuous PMW duty cycles when in PWM dimming mode), the \overline{FAULT} pin goes low, keeping the open channel on and turning the other channel off. With the \overline{FAULT} pin tied high, all channels remain turned on. The channel recovers on removal of the open condition. Note that the device can detect an open load if the sum of the forward voltages of the LEDs in a string is close to or greater than the supply voltage on VIN.

Table 1. Fault Table^{(1) (2)}

FAILURE MODE	JUDGMENT CONDITION			DIAGNOSTIC OUTPUT PINS	ACTION	FAULT AND FAULT_S ⁽³⁾	DEVICE REACTION	FAILURE REMOVED	SELF-CLEARING
	DETECTION VIN VOLTAGE	CHANNEL STATUS	DETECTION MECHANISM						
Short circuit: 1 or several LED strings	$V_{(VIN)} > 5\text{ V}$	ON	$V_{(IOUTx)} < 0.9\text{ V}$	\overline{FAULT}	Pulled low	Externally pulled high	Failing strings turned off, other channels on	Toggle EN, power cycle	No
						Floating	All strings turned OFF	Toggle EN, power cycle	
Single-LED short circuit: 1 or several LED strings	$V_{(VIN)} > 9\text{ V}$	ON	$V_{(VSNSx)} < 1.222\text{ V}$	$\overline{FAULT_S}$	Pulled low	Externally pulled high	All strings stay ON	Toggle EN, power cycle	No
						Floating	All strings stay ON	Toggle EN, power cycle	
Open load: 1 or several LED strings	$V_{(VIN)} > 5\text{ V}$	ON	$V_{(VIN)} - V_{(IOUTx)} < 100\text{ mV}$	\overline{FAULT}	Pulled low	Externally pulled high	All strings stay ON		Yes
						Floating	Failing string stays ON, other channels turned OFF		
Short to battery: 1 or several LED strings	$V_{(VIN)} > 5\text{ V}$	ON or OFF	$V_{(VIN)} - V_{(IOUTx)} < 100\text{ mV}$	\overline{FAULT}	Pulled low	Externally pulled high	All strings stay ON		Yes
						Floating	Failing string stays ON, other channels turned OFF		
Thermal shutdown	$V_{(VIN)} > 5\text{ V}$	ON or OFF	Temperature > 170°C	\overline{FAULT}	Pulled low	Externally pulled high	All strings turned OFF	Temperature < 155°C	Yes
						Leave open			
Thermal foldback	$V_{(VIN)} > 5\text{ V}$	ON or OFF	Temperature > 110°C	N/A	None	N/A	All strings with reduced current	Temperature < 100°C	Yes

(1) With diagnostic pins \overline{FAULT} and $\overline{FAULT_S}$ tied high externally, pullup must be strong enough to override internal pulldown.
 (2) To achieve single-LED short circuit to turn off all strings, $\overline{FAULT_S}$ and \overline{FAULT} pins must be connected together.
 (3) Pulling \overline{FAULT} and $\overline{FAULT_S}$ high externally changes the behavior of the device reaction. If not externally forced high, the device pulls the pins low based on the failure mode.

Feature Description (continued)

Table 1. Fault Table^{(1) (2)} (continued)

FAILURE MODE	JUDGMENT CONDITION			DIAGNOSTIC OUTPUT PINS	ACTION	FAULT AND FAULT_S ⁽³⁾	DEVICE REACTION	FAILURE REMOVED	SELF-CLEARING
	DETECTION VIN VOLTAGE	CHANNEL STATUS	DETECTION MECHANISM						
Reference resistor open or shorted	V _(VIN) > 5 V	ON or OFF	R _(REF) > 57 kΩ or R _(REF) < 350 Ω	FAULT	Pulled low	N/A	All strings turned OFF	Toggle EN, power cycle	No

10.3.6 Thermal Foldback

The TPS92630-Q1 device integrates thermal shutdown protection to prevent the device from overheating. In addition, to prevent LEDs from flickering because of rapid thermal changes, the device includes a programmable thermal current-foldback feature to reduce power dissipation at high junction temperatures.

The TPS92630-Q1 device reduces the LED current as the silicon junction temperature of the TPS92630-Q1 device increases (see Figure 23). By mounting the TPS92630-Q1 device on the same thermal substrate as the LEDs, use of this feature can also limit the dissipation of the LEDs. As the junction temperature of the TPS92630-Q1 device increases, the device reduces the regulated current, reducing the dissipated power in the TPS92630-Q1 device and in the LEDs. The current reduction is from the 100% level at typically 2% of I_(setting) per °C until the point at which the current drops to 50% of the full value.

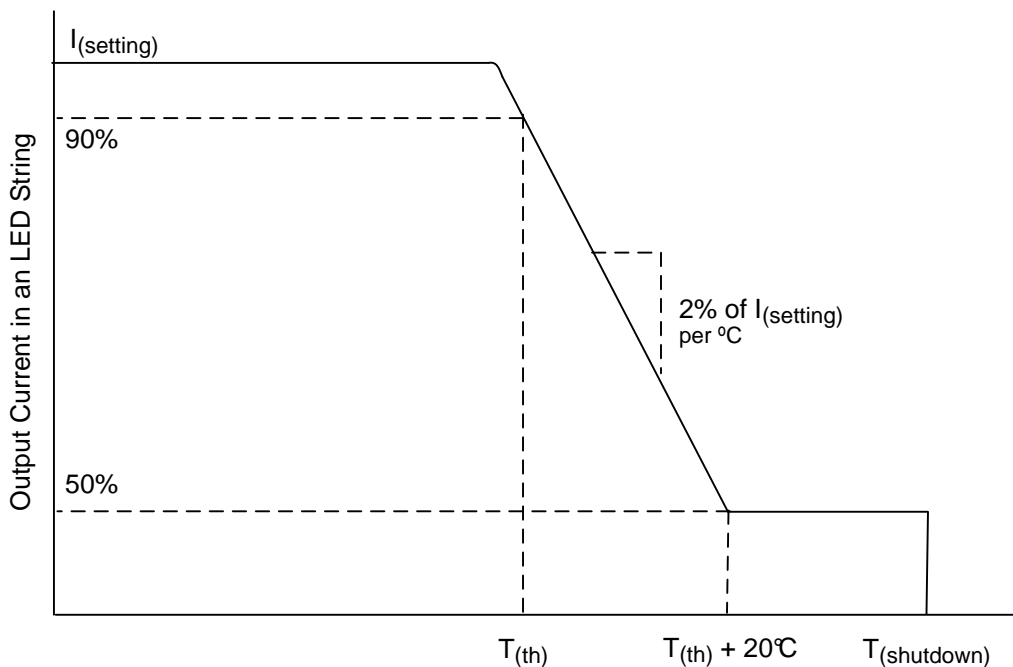

Figure 23. Thermal Foldback

Above this temperature, the current continues to decrease at a lower rate until the temperature reaches the overtemperature shutdown threshold temperature, T_(shutdown). Changing the voltage on the TEMP pin adjusts the temperature at which the current reduction begins. With TEMP floating, the definition of thermal monitor activation temperature, T_(th), is the temperature at which the current reduction begins. The specification of T_(th) in the characteristics table is at the 90% current level. T_(th) increases as the voltage at the TEMP pin, V_(TEMP), declines and is defined as approximately:

$$T_{(th)} = -121.7 V_{(TEMP)} + 228.32 \tag{4}$$

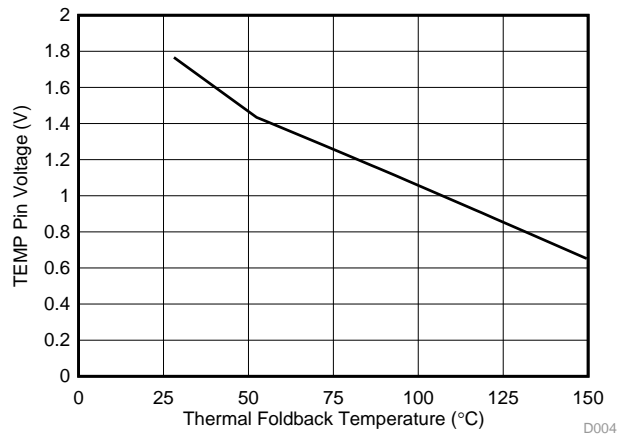

Figure 24. TEMP Pin Voltage vs Temperature

A resistor connected between TEMP and GND reduces $V_{(TEMP)}$ and increases $T_{(th)}$. A resistor connected between TEMP and a reference supply greater than 1 V increases $V_{(TEMP)}$ and reduces $T_{(th)}$.

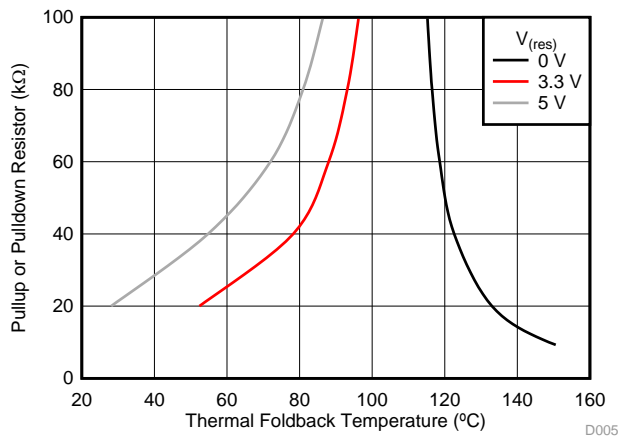

Figure 25. Pullup and Pulldown Resistors vs $T_{(th)}$

Figure 25 shows how the nominal value of the thermal-monitor activation temperature varies with the voltage at TEMP and with either a pulldown resistor to GND or with a pullup resistor to 3.3 V or 5 V.

In extreme cases, if the junction temperature exceeds the overtemperature limit, $T_{(shutdown)}$, the device disables all channels. Temperature monitoring continues, and channel reactivation occurs when the temperature drops below the threshold provided by the specified hysteresis.

Note the possibility of the TPS92630-Q1 device transitioning rapidly between thermal shutdown and normal operation. This can happen if the thermal mass attached to the exposed thermal pad is small and $T_{(th)}$ is increased to close to the shutdown temperature. The period of oscillation depends on $T_{(th)}$, the dissipated power, the thermal mass of any heatsink present, and the ambient temperature.

10.4 Device Functional Modes

10.4.1 Thermal Information

This device operates a thermal shutdown (TSD) circuit as a protection from overheating. For continuous normal operation, the junction temperature should not exceed the thermal-shutdown trip point. If the junction temperature exceeds the thermal-shutdown trip point, the output turns off. When the junction temperature falls below the thermal-shutdown trip point, the output turns on again.

Calculate the power dissipated by the device according to the following formula:

Device Functional Modes (continued)

$$P_T = V_{(VIN)} \times I_{(VIN)} - n_1 \times V_{(LED1)} \times I_{(LED1)} - n_2 \times V_{(LED2)} \times I_{(LED2)} - n_3 \times V_{(LED3)} \times I_{(LED3)} - V_{ref}^2 / R_{(REF)} \quad (5)$$

where:

P_T = Total power dissipation of the device

n_x = Number of LEDs for channel x

$V_{(LEDx)}$ = Voltage drop across one LED for channel x

V_{ref} = Reference voltage, typically 1.222 V

$I_{(LEDx)}$ = Average LED current for channel x

After determining the power dissipated by the device, calculate the junction temperature from the ambient temperature and the device thermal impedance.

$$T_J = T_A + R_{\theta JA} \times P_T \quad (6)$$

10.4.2 Operation With $V_{(VIN)} < 5$ V (Minimum $V_{(VIN)}$)

The devices operate with input voltages above 5 V. The devices start working when $V_{(VIN)} > 4$ V, but while 4 V $< V_{(VIN)} < 5$ V, the devices shield all the fault status. With fault status shielded, if any fault occurs the devices may not report the fault and take the correct action.

10.4.3 Operation With 5 V $< V_{(VIN)} < 9$ V (Lower-Than-Normal Automotive Battery Voltage)

The devices operate with input voltages above 5 V. When the input voltage is lower than normal automotive 9 V, the devices shield single-LED-short fault status. With fault status shielded, if a single-LED-short fault occurs the devices do not report the fault with the `FAULT_S` pin.

11 Applications and Implementation

NOTE

Information in the following applications sections is not part of the TI component specification, and TI does not warrant its accuracy or completeness. TI's customers are responsible for determining suitability of components for their purposes. Customers should validate and test their design implementation to confirm system functionality.

11.1 Application Information

The following discussion includes several applications showing how to implement the TPS92630-Q1 device for automotive lighting such as stop lights and taillights. Some of the examples demonstrate implementation of the fault bus function or detail use of the device for higher-current applications.

11.2 Typical Applications

11.2.1 Stoplight and Taillight Application With PWM Generator

Another easy way to achieve the different brightness is dimming by pulse-width modulation (PWM), which holds the color spectrum of the LED over the whole brightness range. The maximum current that passes through the LED is programmable by sense resistor R_{REF} .

Figure 26 shows the application circuit of the stoplight and taillight including an automotive-qualified timer, TLC555-Q1, the duty cycle of which is programmable by two external resistors. One can see that driving the STOP signal high pulls the PWM pin constantly high, creating 100% duty cycle. Thus the LEDs operate at full brightness. When the TAIL signal is high, the LEDs operate at 50% brightness because the TLC555-Q1 timer is programmed at a fixed duty cycle of 50%.

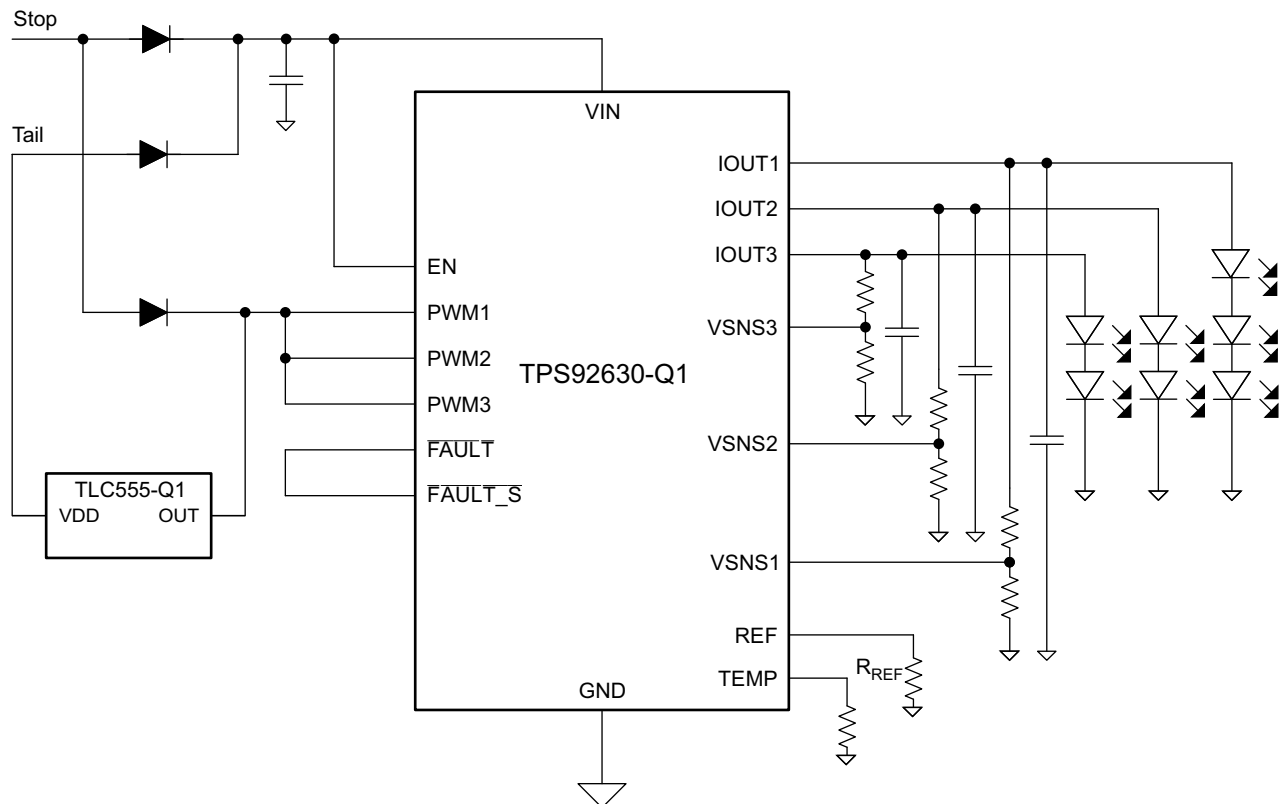

Figure 26. Two-Level Brightness Adjustment Using the TPS92630-Q1 With PWM

Typical Applications (continued)

11.2.1.1 Design Requirements

For this design example, use the following as the input parameters.

Table 2. Design Parameters

DESIGN PARAMETER	EXAMPLE VALUE
$I_{(tail)}$	75
$I_{(stop)}$	150

11.2.1.2 Detailed Design Procedure

11.2.1.2.1 Step-by-Step Design Procedure

To begin the design process, one must decide on a few parameters. The designer must know the following:

- $I_{(tail)}$ – Taillight current
- $I_{(stop)}$ – Stop-light current

11.2.1.2.1.1 $R_{(REF)}$

$$R_{(REF)} = V_{ref} \times K_{(I)} / I_{(stop)} = 1.222 \times 100 / 0.15 = 814 \Omega \quad (7)$$

11.2.1.2.1.2 Duty Cycle

$$\text{Duty cycle} = I_{(tail)} / I_{(stop)} = 75 / 150 = 50\% \quad (8)$$

11.2.1.2.1.3 Input and Output Capacitors

TI recommends to add capacitors at VIN and IOUtx. TI recommends an input capacitor of at least 1 μ F close to the VIN pin, and output capacitors of 10 nF close to the IOUtx pins. Larger capacitors are helpful for EMC and ESD; however, it takes a longer time to charge up the capacitor and could affect PWM dimming performance.

11.2.1.3 PWM Dimming Application Curve

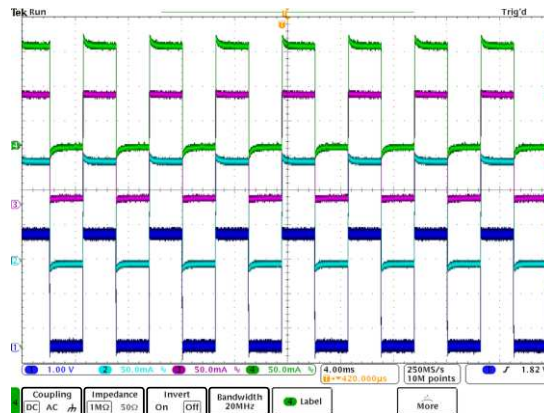

Figure 27. PWM Dimming Application Curve

11.2.2 Simple Stop-Light and Taillight Application

For many automobiles, the same set of LEDs illuminates both taillights and stop lights. Thus, the LEDs must operate at two different brightness levels. Figure 28 shows two-level brightness adjustment using the TPS92630-Q1 device with minimum external components. Set the dimming level with a parallel resistor in REF through an external MOS. See Equation 9 for details.

$$I_{(IOUTx)} = \frac{V_{ref} \times K_{(I)}}{R_{(REF)} \times R_{(Stop)} / (R_{(REF)} + R_{(Stop)})} \quad (9)$$

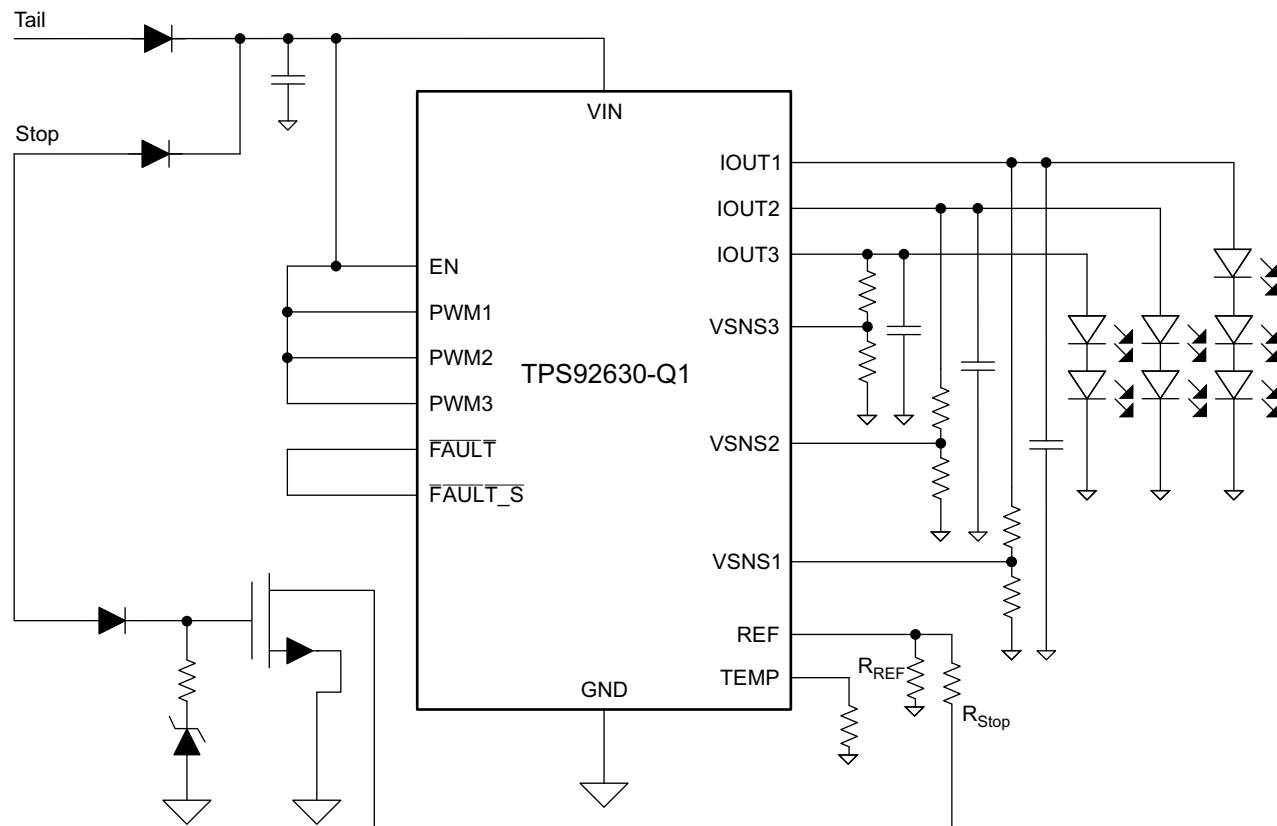

Figure 28. Two-Level Brightness Adjustment Using the TPS92630-Q1 Device With Minimum External Components

11.2.2.1 Design Requirements

For this design example, use the following as the input parameters.

Table 3. Design Parameters

DESIGN PARAMETER	EXAMPLE VALUE
$I_{(Tail)}$	30 mA
$I_{(Stop)}$	70 mA

11.2.2.2 Detailed Design Procedure

11.2.2.2.1 Step-by-Step Design Procedure

To begin the design process, one must decide on a few parameters. The designer must know the following:

- $I_{(Tail)}$ – Taillight current
- $I_{(Stop)}$ – Stop-light current

11.2.2.2.1.1 $R_{(REF)}$

$$R_{(REF)} = V_{ref} \times K_{(I)} / I_{(tail)} = 1.222 \times 100 / 0.03 = 4.072 \text{ k}\Omega \quad (10)$$

11.2.2.2.1.2 $R_{(Stop)}$

$$R_{(Stop)} = V_{ref} \times K_{(I)} / (I_{(stop)} - I_{(tail)}) = 1.222 \times 100 / (0.07 - 0.03) = 3.055 \text{ k}\Omega \quad (11)$$

11.2.2.2.1.3 Input and Output Capacitors

TI recommends to add capacitors at VIN and IOU_{Tx}. TI recommends an input capacitor of at least 1 μ F close to the VIN pin, and output capacitors of 10 nF close to the IOU_{Tx} pins. Larger capacitors are helpful for EMC and ESD; however, it takes a longer time to charge up the capacitor and could affect PWM dimming performance.

11.2.3 Parallel Connection

This device can drive up to three strings with one to three LEDs in each string, at a total current up to 150 mA per channel. Outputs can be paralleled to provide higher current drive up to 450 mA. For example, if the load current is up to 2 times the device rating, connect the outputs of two devices in parallel as shown in [Figure 29](#).

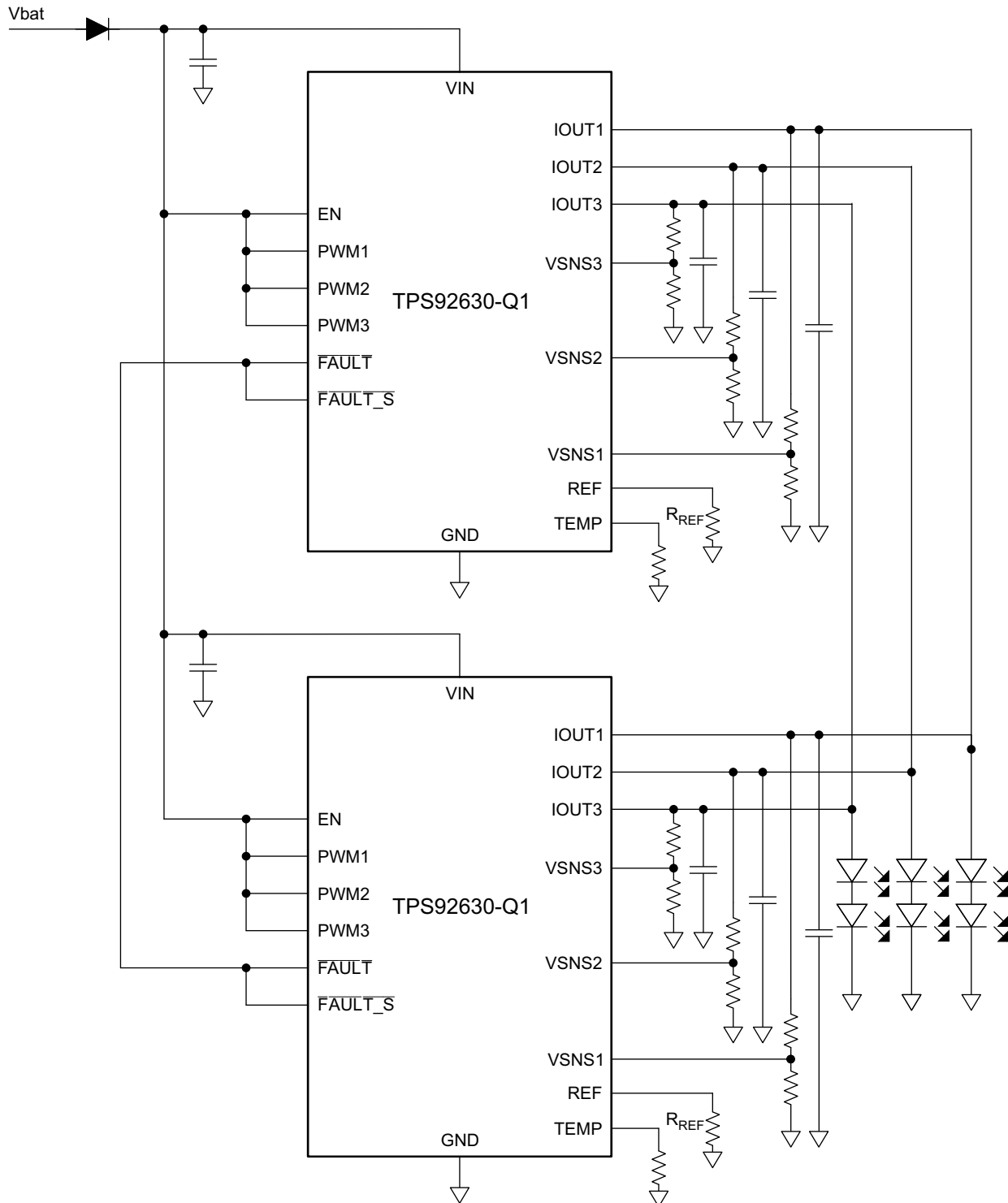

Figure 29. Two TPS92630-Q1 Devices in Parallel for Large Loads

11.2.3.1 Design Requirements

For this design example, use the following as the input parameters.

Table 4. Design Parameters

DESIGN PARAMETER	EXAMPLE VALUE
$I_{(LED)}$ per string	200 mA

11.2.3.2 Detailed Design Procedure

11.2.3.2.1 Step-by-Step Design Procedure

To begin the design process, one must decide on a few parameters. The designer must know the following:

$I_{(LED)}$ per string

11.2.3.2.1.1 $R_{(REF)}$

$$R_{(REF)} = V_{ref} \times K_{(I)} / (I_{(LED)} / \text{Channel}) = 1.222 \times 100 / (200 / 2) = 1.222 \text{ k}\Omega \quad (12)$$

11.2.3.2.1.2 Input and Output Capacitors

TI recommends to add capacitors at VIN and IOUx. TI recommends an input capacitor of at least 1 μ F close to the VIN pin, and output capacitors of 10 nF close to the IOUx pins. Larger capacitors are helpful for EMC and ESD; however, it takes a longer time to charge up the capacitor and could affect PWM dimming performance.

11.2.4 Alternate Parallel Connection

An alternate method of connecting two devices in parallel drives six LEDs while getting better thermal performance (see [Figure 30](#)).

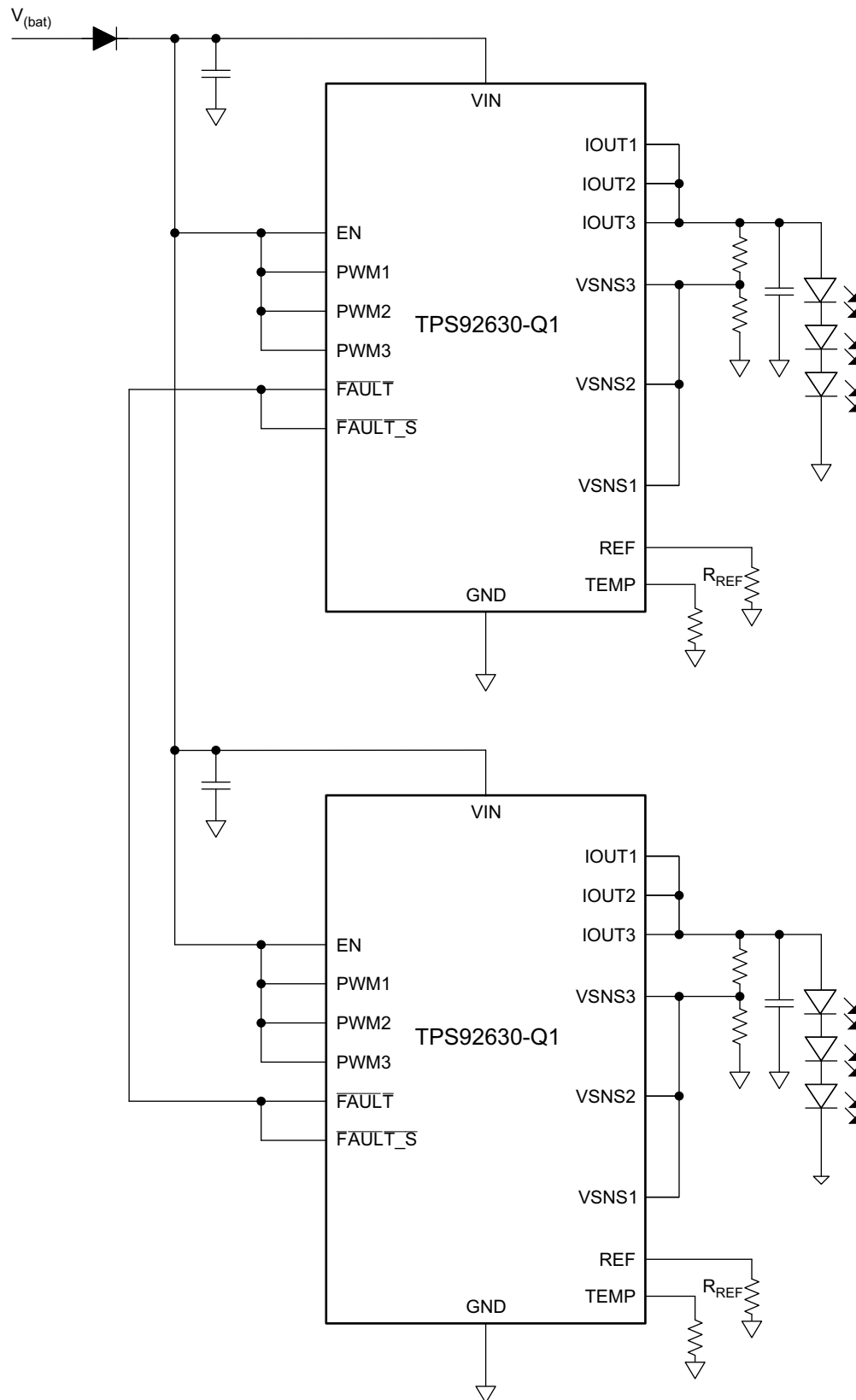

Figure 30. Two TPS92630-Q1 Devices in Parallel for Large Loads

11.2.4.1 Design Requirements

For this design example, use the following as the input parameters.

Table 5. Design Parameters

DESIGN PARAMETER	EXAMPLE VALUE
$I_{(LED)}$ per string	300 mA

11.2.4.2 Detailed Design Procedure

11.2.4.2.1 Step-by-Step Design Procedure

To begin the design process, one must decide on a few parameters. The designer must know the following:

$I_{(LED)}$ per string

11.2.4.2.1.1 $R_{(REF)}$

$$R_{(REF)} = V_{ref} \times K_{(I)} / (I_{(LED)} / \text{channel}) = 1.222 \times 100 / (300 / 3) = 1.222 \text{ k}\Omega \quad (13)$$

11.2.4.2.1.2 Input and Output Capacitors

TI recommends to add capacitors at VIN and IOUTx. TI recommends an input capacitor of at least 1 μF close to the VIN pin, and output capacitors of 10 nF close to the IOUTx pins. Larger capacitors are helpful for EMC and ESD; however, it takes a longer time to charge up the capacitor and could affect PWM dimming performance.

11.2.5 High-Side PWM Dimming

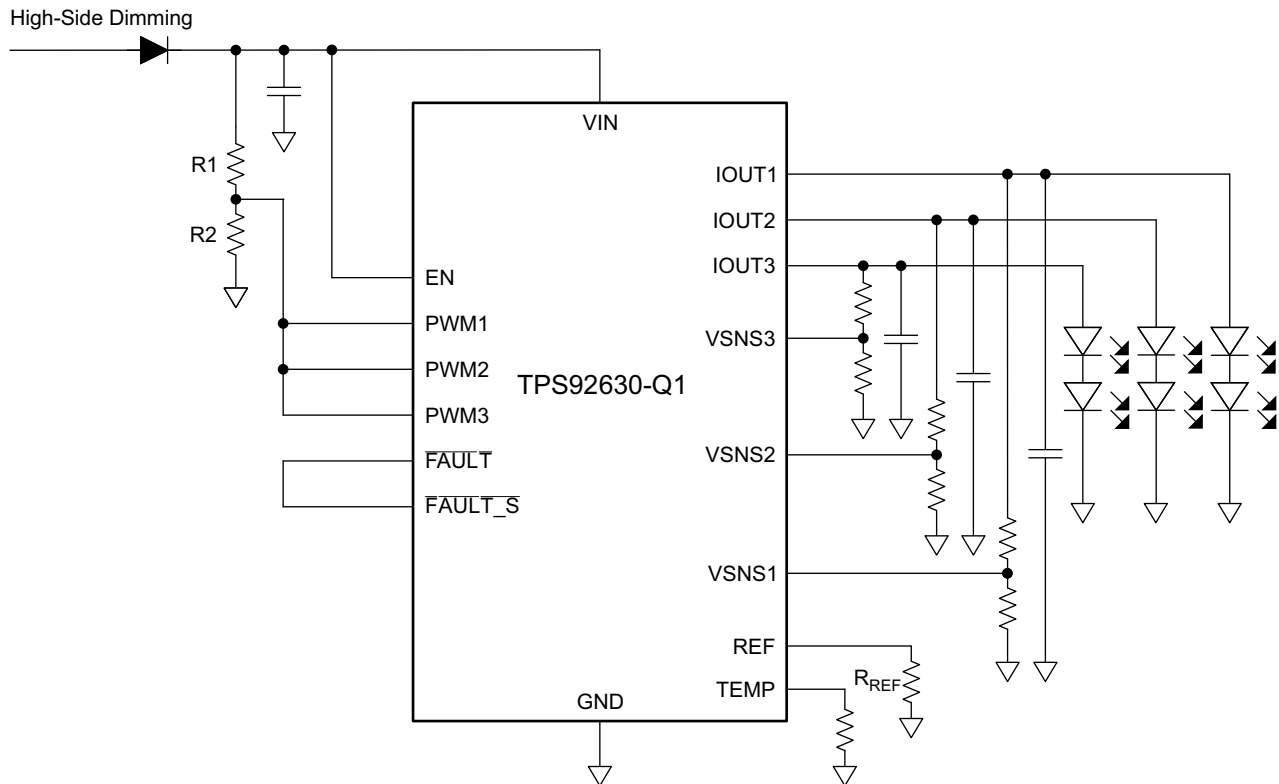

Figure 31. High-Side PWM Dimming

11.2.5.1 Design Requirements

For this design example, use the following as the input parameters.

Table 6. Design Parameters

DESIGN PARAMETER	EXAMPLE VALUE
$V_{(VIN-low)}$	7 V

11.2.5.2 Detailed Design Procedure

If the system has no MCU or PWM, one can use the high-side driver to do the dimming directly. When using the high-side driver to do PWM dimming, a resistor divider must be put in the PWM pin in case of current overshoot on the PWM rising edge. The resistor divider is needed to turn off the channel before the next PWM rising edge.

11.2.5.2.1 Step-by-Step Design Procedure

To begin the design process, one must decide on a parameter. The designer must know the value for $V_{(VIN-low)}$.

11.2.5.2.1.1 Ratio of Resistors, R1 / R2

First, measure the voltage on the VIN pin when the high-side dimming voltage is at a low level. Then calculate the ratio of R1 / R2 using the formula of [Equation 14](#).

$$\frac{R1}{R2} = \frac{V_{(VIN-low)} + 0.1}{1.178 \times 0.95} \quad (14)$$

Assuming that the measured voltage was 7 V, the R1 / R2 ratio would be 5.25.

11.2.5.2.1.2 R1 and R2 Selection

Select R1 = 105 kΩ and R2 = 20 kΩ.

11.2.5.2.1.3 Input and Output Capacitors

TI recommends to add capacitors at VIN and IOUTx. TI recommends an input capacitor of at least 1 μF close to the VIN pin, and output capacitors of 10 nF close to the IOUTx pins. Larger capacitors are helpful for EMC and ESD; however, it takes a longer time to charge up the capacitor and could affect PWM dimming performance.

12 Power Supply Recommendations

The TPS92630-Q1 device is qualified for automotive applications. The normal power supply connection is therefore to an automobile electrical system that provides a voltage within the range specified in the [Recommended Operating Conditions](#).

13 Layout

13.1 Layout Guidelines

In order to prevent thermal shutdown, T_J must be less than 150°C. If the input voltage is very high, the power dissipation might be large. The devices are currently available in the TSSOP-EP package, which has good thermal impedance. However, the PCB layout is also very important. Good PCB design can optimize heat transfer, which is absolutely essential for the long-term reliability of the device.

- Maximize the copper coverage on the PCB to increase the thermal conductivity of the board, because the major heat-flow path from the package to the ambient is through the copper on the PCB. Maximum copper is extremely important when the design does not include heat sinks attached to the PCB on the other side of the package.
- Add as many thermal vias as possible directly under the package ground pad to optimize the thermal conductivity of the board.
- All thermal vias should be either plated shut or plugged and capped on both sides of the board to prevent solder voids. To ensure reliability and performance, the solder coverage should be at least 85 percent.

13.2 Layout Example

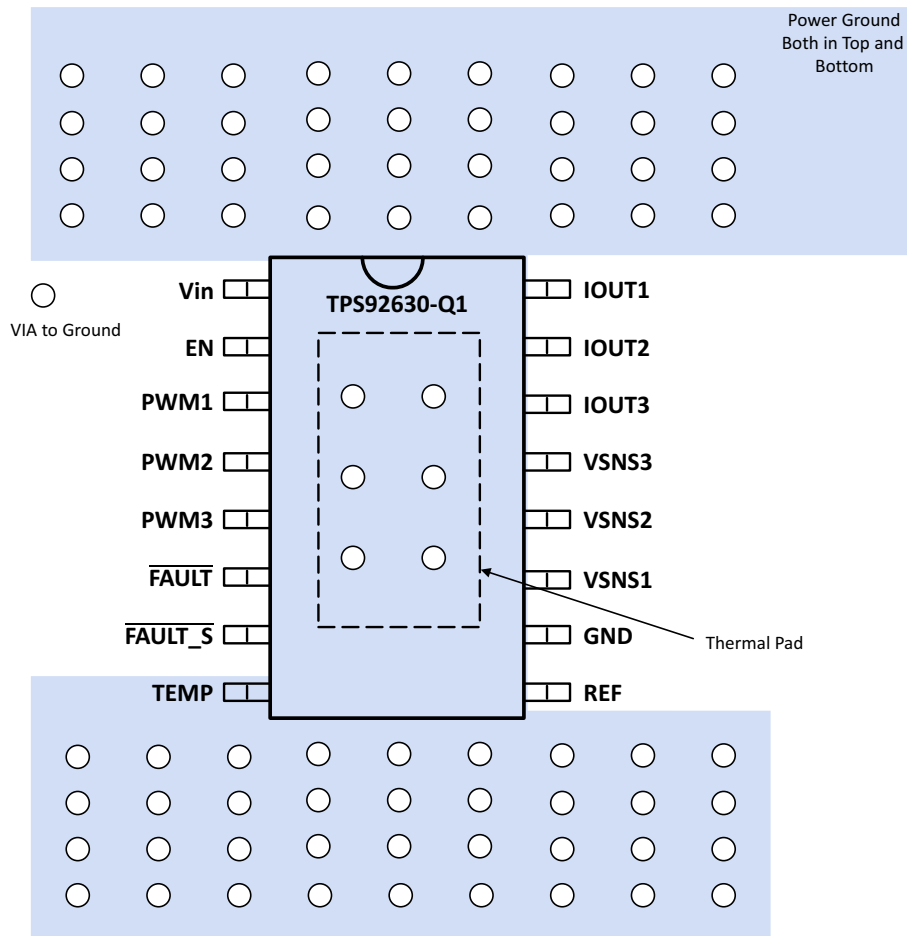

Figure 32. TPS92630-Q1 Board Layout Diagram

14 Device and Documentation Support

14.1 Documentation Support

14.1.1 Related Documentation

For related documentation see the following:

- [How to Calculate TPS92630-Q1 Maximum Output Current for Automotive Exterior Lighting Applications](#)
- [CISPR25 Automotive Tail Light Reference Design for Step-Down + Linear LED Driver Based Systems](#)
- [CISPR25 Tested Automotive Tail Light Reference Design for Step-Up + Linear LED Driver Based Systems](#)
- [Linear LED Driver Reference Design for Automotive Lighting Applications](#)
- [Automotive High Side Dimming Rear Light Reference Design](#)
- [Automotive Rear Light EMC Reference Design](#)

14.2 Receiving Notification of Documentation Updates

To receive notification of documentation updates, navigate to the device product folder on ti.com. In the upper right corner, click on *Alert me* to register and receive a weekly digest of any product information that has changed. For change details, review the revision history included in any revised document.

14.3 Community Resources

The following links connect to TI community resources. Linked contents are provided "AS IS" by the respective contributors. They do not constitute TI specifications and do not necessarily reflect TI's views; see TI's [Terms of Use](#).

TI E2E™ Online Community *TI's Engineer-to-Engineer (E2E) Community*. Created to foster collaboration among engineers. At e2e.ti.com, you can ask questions, share knowledge, explore ideas and help solve problems with fellow engineers.

Design Support *TI's Design Support* Quickly find helpful E2E forums along with design support tools and contact information for technical support.

14.4 Trademarks

PowerPAD, E2E are trademarks of Texas Instruments.
All other trademarks are the property of their respective owners.

14.5 Electrostatic Discharge Caution



This integrated circuit can be damaged by ESD. Texas Instruments recommends that all integrated circuits be handled with appropriate precautions. Failure to observe proper handling and installation procedures can cause damage.

ESD damage can range from subtle performance degradation to complete device failure. Precision integrated circuits may be more susceptible to damage because very small parametric changes could cause the device not to meet its published specifications.

14.6 Glossary

[SLYZ022](#) — *TI Glossary*.

This glossary lists and explains terms, acronyms, and definitions.

15 Mechanical, Packaging, and Orderable Information

The following pages include mechanical, packaging, and orderable information. This information is the most-current data available for the designated device. This data is subject to change without notice and without revision of this document. For browser-based versions of this data sheet, see the left-hand navigation pane.

PACKAGING INFORMATION

Orderable Device	Status (1)	Package Type	Package Drawing	Pins	Package Qty	Eco Plan (2)	Lead finish/ Ball material (6)	MSL Peak Temp (3)	Op Temp (°C)	Device Marking (4/5)	Samples
TPS92630QPWRQ1	ACTIVE	HTSSOP	PWP	16	2000	RoHS & Green	NIPDAU	Level-3-260C-168 HR	-40 to 125	92630	Samples

(1) The marketing status values are defined as follows:

ACTIVE: Product device recommended for new designs.

LIFEBUY: TI has announced that the device will be discontinued, and a lifetime-buy period is in effect.

NRND: Not recommended for new designs. Device is in production to support existing customers, but TI does not recommend using this part in a new design.

PREVIEW: Device has been announced but is not in production. Samples may or may not be available.

OBSELETE: TI has discontinued the production of the device.

(2) **RoHS:** TI defines "RoHS" to mean semiconductor products that are compliant with the current EU RoHS requirements for all 10 RoHS substances, including the requirement that RoHS substance do not exceed 0.1% by weight in homogeneous materials. Where designed to be soldered at high temperatures, "RoHS" products are suitable for use in specified lead-free processes. TI may reference these types of products as "Pb-Free".

RoHS Exempt: TI defines "RoHS Exempt" to mean products that contain lead but are compliant with EU RoHS pursuant to a specific EU RoHS exemption.

Green: TI defines "Green" to mean the content of Chlorine (Cl) and Bromine (Br) based flame retardants meet JS709B low halogen requirements of <=1000ppm threshold. Antimony trioxide based flame retardants must also meet the <=1000ppm threshold requirement.

(3) MSL, Peak Temp. - The Moisture Sensitivity Level rating according to the JEDEC industry standard classifications, and peak solder temperature.

(4) There may be additional marking, which relates to the logo, the lot trace code information, or the environmental category on the device.

(5) Multiple Device Markings will be inside parentheses. Only one Device Marking contained in parentheses and separated by a "-" will appear on a device. If a line is indented then it is a continuation of the previous line and the two combined represent the entire Device Marking for that device.

(6) Lead finish/Ball material - Orderable Devices may have multiple material finish options. Finish options are separated by a vertical ruled line. Lead finish/Ball material values may wrap to two lines if the finish value exceeds the maximum column width.

Important Information and Disclaimer:The information provided on this page represents TI's knowledge and belief as of the date that it is provided. TI bases its knowledge and belief on information provided by third parties, and makes no representation or warranty as to the accuracy of such information. Efforts are underway to better integrate information from third parties. TI has taken and continues to take reasonable steps to provide representative and accurate information but may not have conducted destructive testing or chemical analysis on incoming materials and chemicals. TI and TI suppliers consider certain information to be proprietary, and thus CAS numbers and other limited information may not be available for release.

In no event shall TI's liability arising out of such information exceed the total purchase price of the TI part(s) at issue in this document sold by TI to Customer on an annual basis.

TAPE AND REEL INFORMATION



QUADRANT ASSIGNMENTS FOR PIN 1 ORIENTATION IN TAPE



*All dimensions are nominal

Device	Package Type	Package Drawing	Pins	SPQ	Reel Diameter (mm)	Reel Width W1 (mm)	A0 (mm)	B0 (mm)	K0 (mm)	P1 (mm)	W (mm)	Pin1 Quadrant
TPS92630QPWPRQ1	HTSSOP	PWP	16	2000	330.0	12.4	6.9	5.6	1.6	8.0	12.0	Q1

TAPE AND REEL BOX DIMENSIONS



*All dimensions are nominal

Device	Package Type	Package Drawing	Pins	SPQ	Length (mm)	Width (mm)	Height (mm)
TPS92630QPWPRQ1	HTSSOP	PWP	16	2000	350.0	350.0	43.0

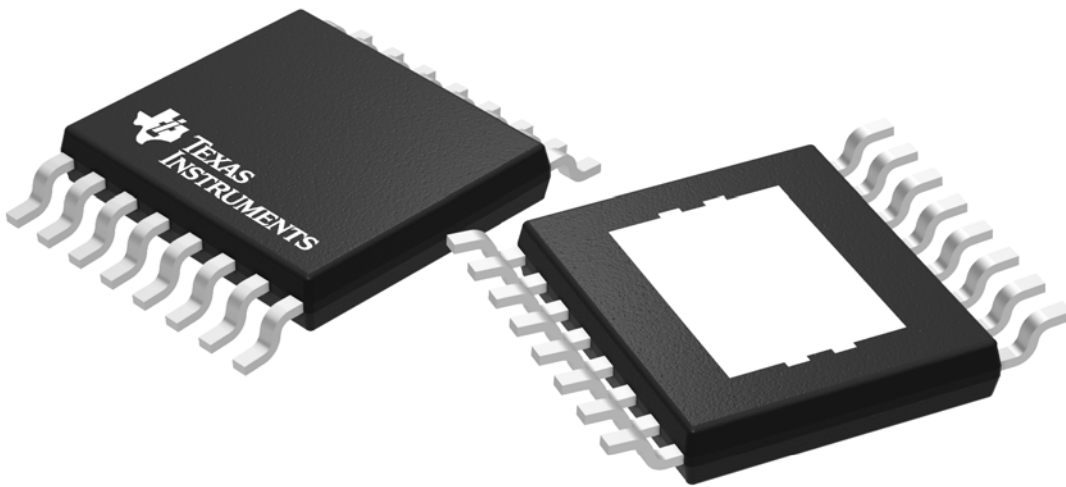

Images above are just a representation of the package family, actual package may vary.
Refer to the product data sheet for package details.

PWP0016A

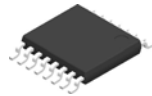

PACKAGE OUTLINE

PowerPAD™ HTSSOP - 1.2 mm max height

PLASTIC SMALL OUTLINE

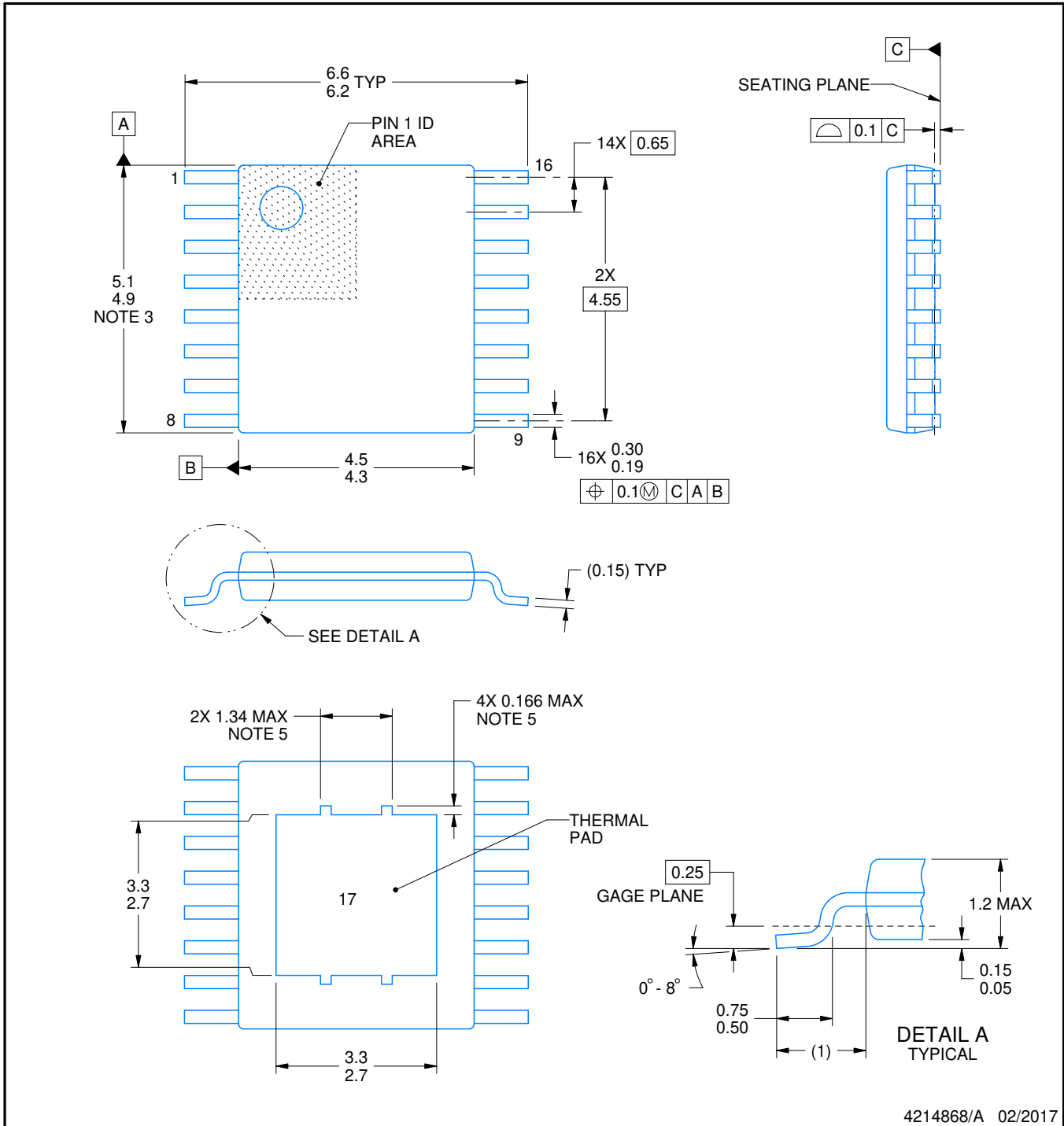

4214868/A 02/2017

NOTES:

PowerPAD is a trademark of Texas Instruments.

1. All linear dimensions are in millimeters. Any dimensions in parenthesis are for reference only. Dimensioning and tolerancing per ASME Y14.5M.
2. This drawing is subject to change without notice.
3. This dimension does not include mold flash, protrusions, or gate burrs. Mold flash, protrusions, or gate burrs shall not exceed 0.15 mm per side.
4. Reference JEDEC registration MO-153.
5. Features may not be present.

EXAMPLE BOARD LAYOUT

PWP0016A

PowerPAD™ HTSSOP - 1.2 mm max height

PLASTIC SMALL OUTLINE

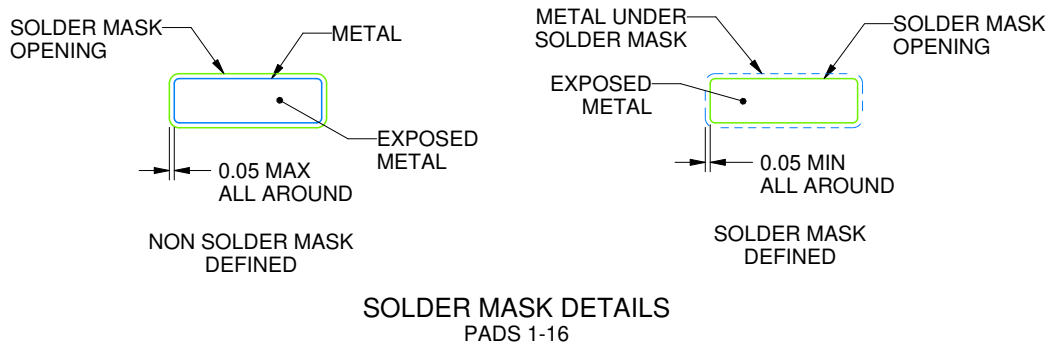
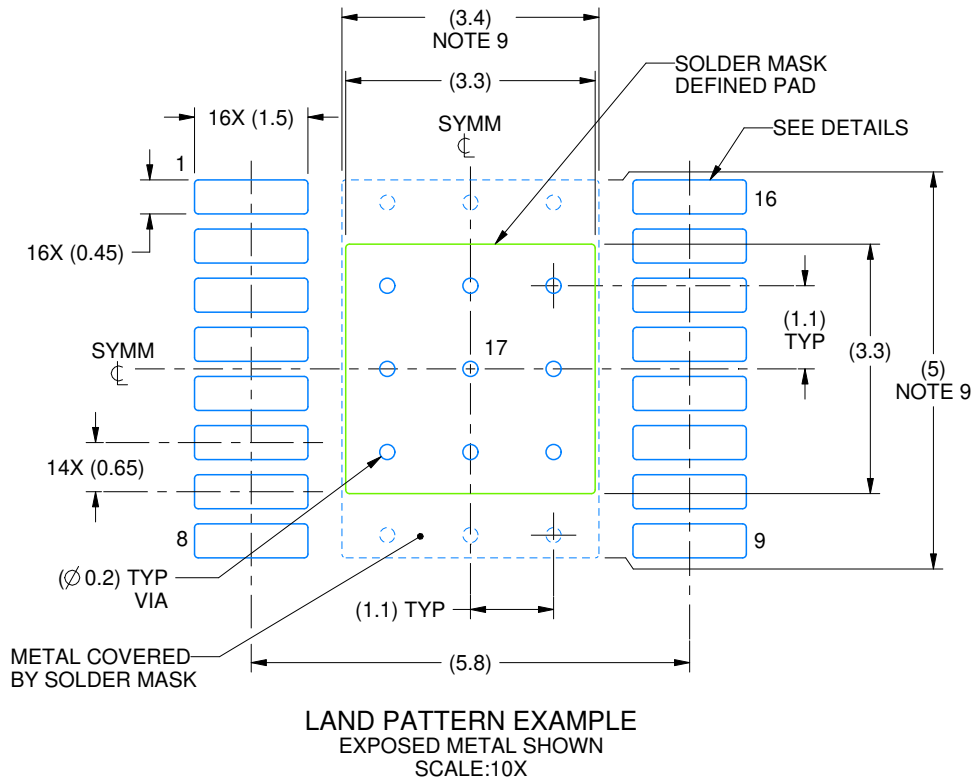

4214868/A 02/2017

NOTES: (continued)

6. Publication IPC-7351 may have alternate designs.
7. Solder mask tolerances between and around signal pads can vary based on board fabrication site.
8. This package is designed to be soldered to a thermal pad on the board. For more information, see Texas Instruments literature numbers SLMA002 (www.ti.com/lit/slma002) and SLMA004 (www.ti.com/lit/slma004).
9. Size of metal pad may vary due to creepage requirement.

EXAMPLE STENCIL DESIGN

PWP0016A

PowerPAD™ HTSSOP - 1.2 mm max height

PLASTIC SMALL OUTLINE

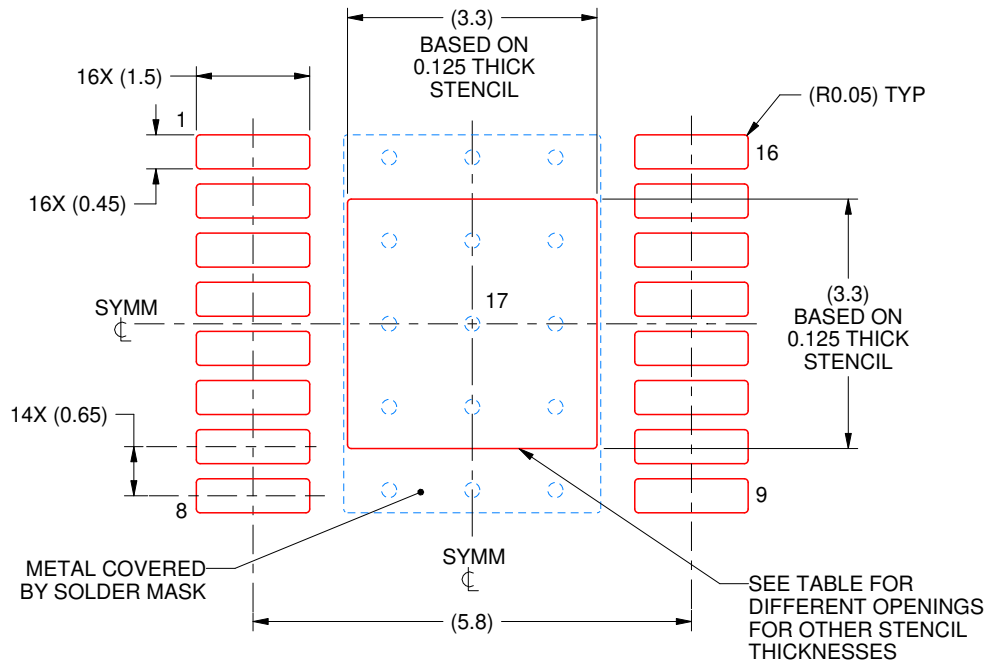

SOLDER PASTE EXAMPLE
 EXPOSED PAD
 100% PRINTED SOLDER COVERAGE BY AREA
 SCALE:10X

STENCIL THICKNESS	SOLDER STENCIL OPENING
0.1	3.69 X 3.69
0.125	3.3 X 3.3 (SHOWN)
0.15	3.01 X 3.01
0.175	2.79 X 2.79

4214868/A 02/2017

NOTES: (continued)

- 10. Laser cutting apertures with trapezoidal walls and rounded corners may offer better paste release. IPC-7525 may have alternate design recommendations.
- 11. Board assembly site may have different recommendations for stencil design.

IMPORTANT NOTICE AND DISCLAIMER

TI PROVIDES TECHNICAL AND RELIABILITY DATA (INCLUDING DATA SHEETS), DESIGN RESOURCES (INCLUDING REFERENCE DESIGNS), APPLICATION OR OTHER DESIGN ADVICE, WEB TOOLS, SAFETY INFORMATION, AND OTHER RESOURCES "AS IS" AND WITH ALL FAULTS, AND DISCLAIMS ALL WARRANTIES, EXPRESS AND IMPLIED, INCLUDING WITHOUT LIMITATION ANY IMPLIED WARRANTIES OF MERCHANTABILITY, FITNESS FOR A PARTICULAR PURPOSE OR NON-INFRINGEMENT OF THIRD PARTY INTELLECTUAL PROPERTY RIGHTS.

These resources are intended for skilled developers designing with TI products. You are solely responsible for (1) selecting the appropriate TI products for your application, (2) designing, validating and testing your application, and (3) ensuring your application meets applicable standards, and any other safety, security, regulatory or other requirements.

These resources are subject to change without notice. TI grants you permission to use these resources only for development of an application that uses the TI products described in the resource. Other reproduction and display of these resources is prohibited. No license is granted to any other TI intellectual property right or to any third party intellectual property right. TI disclaims responsibility for, and you will fully indemnify TI and its representatives against, any claims, damages, costs, losses, and liabilities arising out of your use of these resources.

TI's products are provided subject to [TI's Terms of Sale](#) or other applicable terms available either on [ti.com](https://www.ti.com) or provided in conjunction with such TI products. TI's provision of these resources does not expand or otherwise alter TI's applicable warranties or warranty disclaimers for TI products.

TI objects to and rejects any additional or different terms you may have proposed.

Mailing Address: Texas Instruments, Post Office Box 655303, Dallas, Texas 75265
Copyright © 2023, Texas Instruments Incorporated