

SIGN	DATE	DESCRIPTION	APPROVER

THIS IS CAD DRAWING, DO NOT REVISE MANUALLY!!!

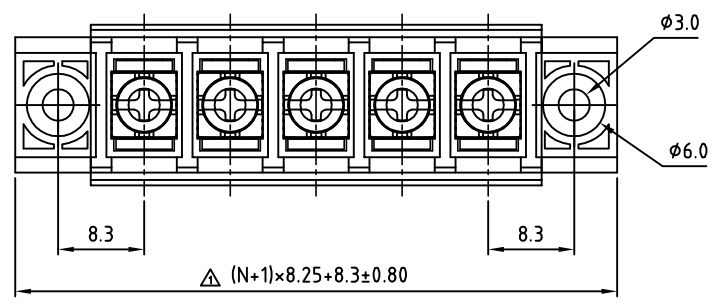

**SPECIFICATIONS**

VOLTAGE & CURRENT: 300 V, 20 A

WITHSTANDING VOLTAGE: AC 2000 V/Min

INSULATION RESISTANCE: 1000 M $\Omega$  OR MORE AT DC 500 V

TEMPERATURE RANGE: -40 °C ~ +105 °C

SCREW TORQUE VALUE: 7 Lb-In.

WIRE RANGE: 22 - 12 AWG

1) MOLDED PARTS: THERMOPLASTIC, UL 94 V-0 BLACK

2) TERMINAL: BRASS, 0.8t, Tin PLATED

3) TERMINAL SCREWS: STEEL, Ni PLATED, M3

4) COVER MATERIAL: PC

APPROVAL: us

RoHS Compliant

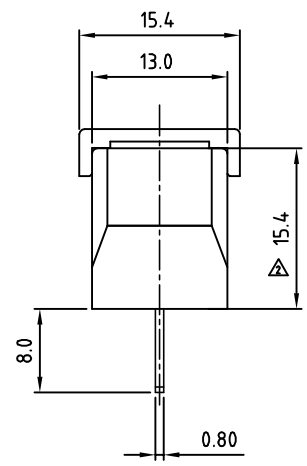
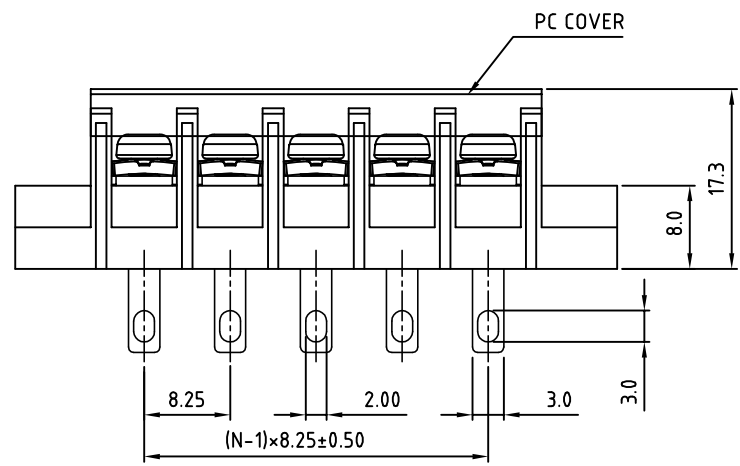

PART NUMBER: OSTYK403XX130

NO. OF POLES

02: 2 POLES

03: 3 POLES

04: 4 POLES

...

30: 30 POLES

N=Number of poles

THESE DRAWINGS AND SPECIFICATIONS ARE THE PROPERTY OF ON-SHORE TECHNOLOGY, INC. AND SHALL NOT BE REPRODUCED, COPIED OR USED IN ANY MANNER WITHOUT THE PRIOR WRITTEN CONSENT OF ON-SHORE TECHNOLOGY, INC.



TITLE		OSTYK-403 With Flange&With Cover Series				
PART NO.	OSTYK403XX130	DWG NO.	OSTYK403XX130.DWG			
APPROVED	CHECKED	DESIGNED	DRAWN	CUST NO.	Tolerance	
Shi Jun 2007.07.18	Seamus 2007.07.18	LUCY 2007.7.18	LUCY 2007.7.18		X. ±0.50	
					X.X ±0.30	
					X.XX ±0.10	
					X° ±1°	
				SHEET: 01/01	REV.: c	