

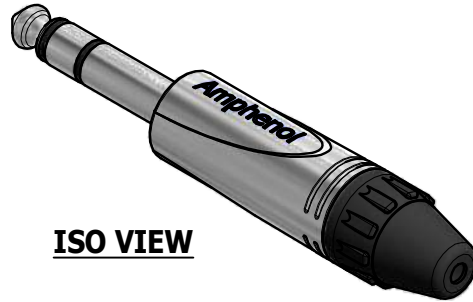

REVISION HISTORY			
REV	DESCRIPTION	DATE	CHG No
1	FIRST ISSUE	30-05-17	----
2	UPDATED CABLE CLAMP	14-03-18	9465

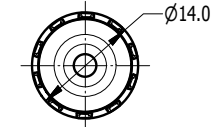

ISO VIEW

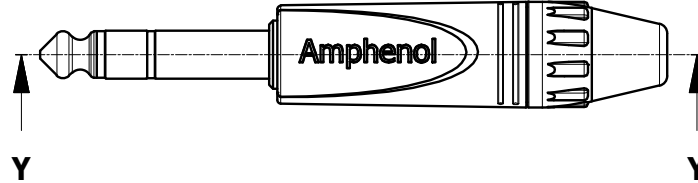
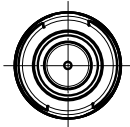
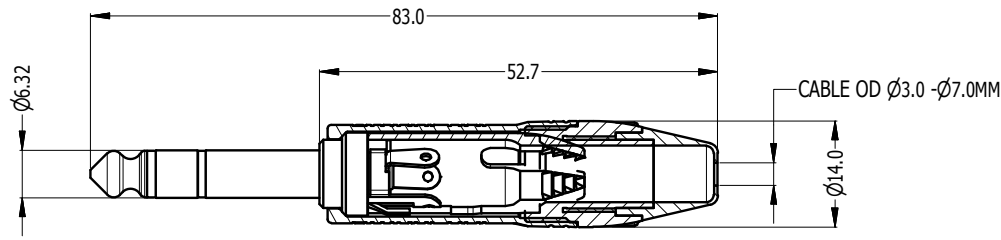

CATALOGUE PN	SHELL FINISH	CONTACT FINISH	BACKSHELL FINISH
QS3P	NICKEL	NICKEL SLEEVE AND TIP	MATT BLACK
QS3PB-AU	MATT BLACK	GOLD SLEEVE AND TIP	MATT BLACK

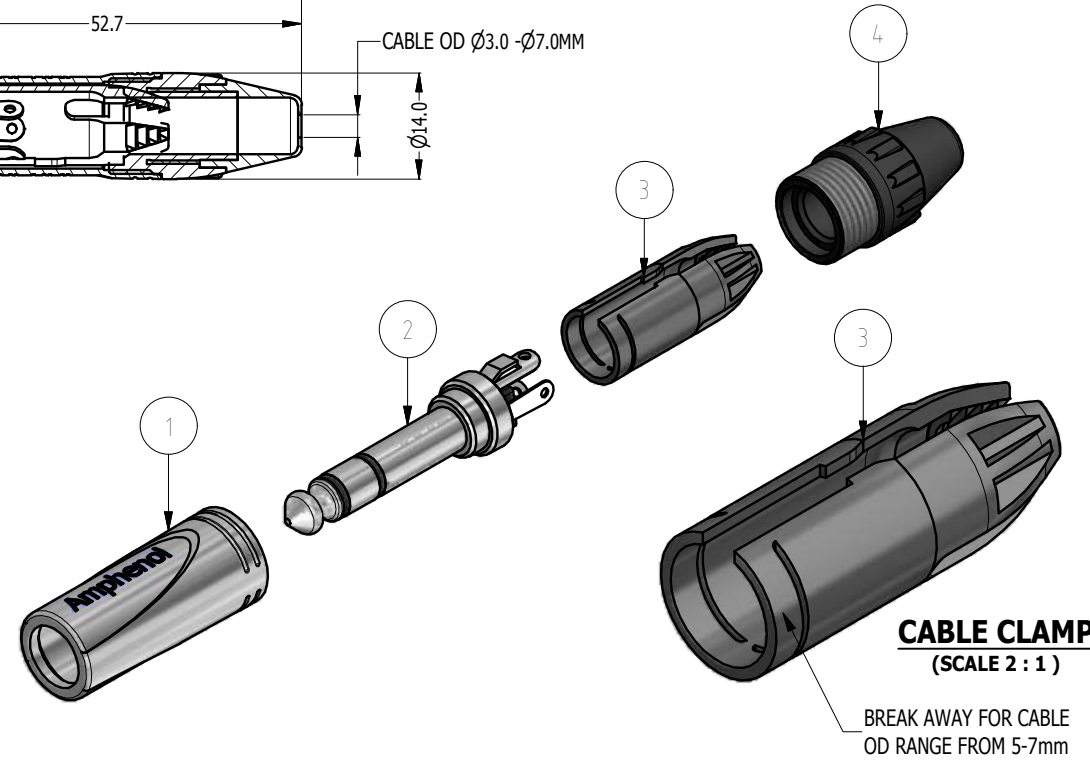

ITEM	PART NUMBER	DESCRIPTION	QTY
4	50440055-000/*00	THERMOPLASTIC BACKSHELL - BLACK/COLOUR	1
3	50260024-500	THERMOPLASTIC CABLE CLAMP - BLACK	1
2	50310064-100/300	MONO INSERT ASSEMBLY - GOLD/NICKEL	1
1	53480189-300/400	DIECAST SHELL - NICKEL/MATT BLACK	1

UNLESS OTHERWISE SPECIFIED TOLERANCE TO BE	
LINEAR	ANGULAR
X ±0.5	X' ±1
X.X ±0.1	X.X' ±30'
X.XX ±0.05	X.XX" ±15'

BREAK ALL SHARP EDGES AND REMOVE ALL BURRS

DO NOT SCALE

THIS DOCUMENT IS THE PROPERTY OF AMPHENOL AUSTRALIA PTY. LTD.
 . NO PART THEREOF MAY BE REPRODUCED AND USED WITHOUT THE PRIOR WRITTEN CONSENT OF THE OWNER

MATERIAL: **REFER TO COMPONENT**

DRN: MH DATE: 30-05-17

CKD: MH DATE: 14-03-18

APP'D: PM DATE: 14-03-18

FINISH: **SEE TABLE**

SCALE: **1:1** SIZE: **A4**

Amphenol Amphenol Australia Pty.Ltd,
 22 Industry Blvd, Carrum Downs, VIC 3201

TITLE: **1/4" PHONE STEREO PLUG CUSTOMER DRAWING**

PART No: **SEE TABLE**

DRAWING NO. **55011235-000-1** SHEET **2/2**

CAD FILE 55011235000111

Parts List

DIMENSIONS IN MILLIMETRES



SCALE: **1:1** SIZE: **A4**

CAD FILE 55011235000111

DRAWING NO. **55011235-000-1** SHEET **2/2**