

PAGE 1/5	ISSUE 1435C	SERIES MMCX	PART NUMBER R110427820
----------	--------------------	--------------------	-------------------------------

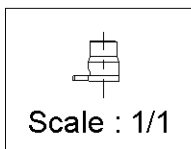

All dimensions are in mm.

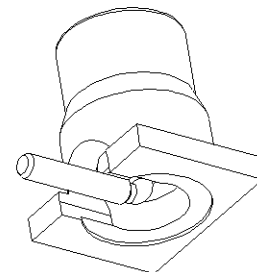
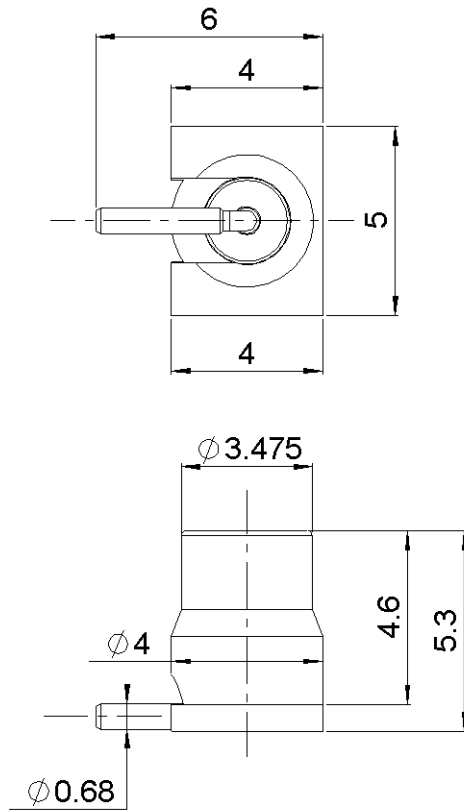
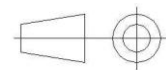

COMPONENTS	MATERIALS	PLATING (μm)
Body	BRASS	NPGR
Center contact	BERYLLIUM COPPER	GOLD OVER NICKEL
Outer contact	-	-
Insulator	PTFE	-
Gasket	-	-
Others parts	-	-
-	-	-
-	-	-

PAGE 2/5	ISSUE 1435C	SERIES MMCX	PART NUMBER R110427820
----------	--------------------	--------------------	-------------------------------

PACKAGING

Standard	Unit	Other
500	Contact us	Contact us

ELECTRICAL CHARACTERISTICS

Impedance		50	Ω
Frequency		0-6	GHz
VSWR	NA	+	0.0000 x F(GHz) Maxi
Insertion loss		NA	√F(GHz) dB Maxi
RF leakage		- (- F(GHz)) dB Maxi
Voltage rating		250	Veff Maxi
Dielectric withstanding voltage		500	Veff mini
Insulation resistance		1000	MΩ mini

ENVIRONMENTAL

Operating temperature	-55/+155	°C
Hermetic seal	NA	Atm.cm3/s
Panel leakage	NA	

MECHANICAL CHARACTERISTICS

Center contact retention			
Axial force – Mating End		10*	N mini
Axial force – Opposite end		10*	N mini
Torque		NA	N.cm mini
Recommended torque			
Mating		NA	N.cm
Panel nut		NA	N.cm
Mating life		500	Cycles mini
Weight		0.3440	g

SPECIFICATION

OTHER CHARACTERISTICS

Assembly instruction:

Others:

*** after soldering (apres soudure)**

SOLDER PROCEDURE IN INDUSTRIAL ENVIRONMENT

1. Deposition of solder paste 'Sn Ag4 Cu0.5' on mounting zone by screen printing application. We recommend a low residue flux.
We advise a thickness of 150 microns (.006 inch). Verify that the edges of the zone are clean.
2. Placement of the receptacle on the mounting zone with an automatic machine of 'pick and place' type.
Video camera is recommended for the positioning of the component. Adhesive agents must not be used on the receptacle.
3. Soldering by infra-red reflow.
Below, please find the typical profile to use.
4. Cleaning of printed circuit boards.
5. Checking of solder joints and position of the component by visual inspection.

TEMPERATURE PROFILE

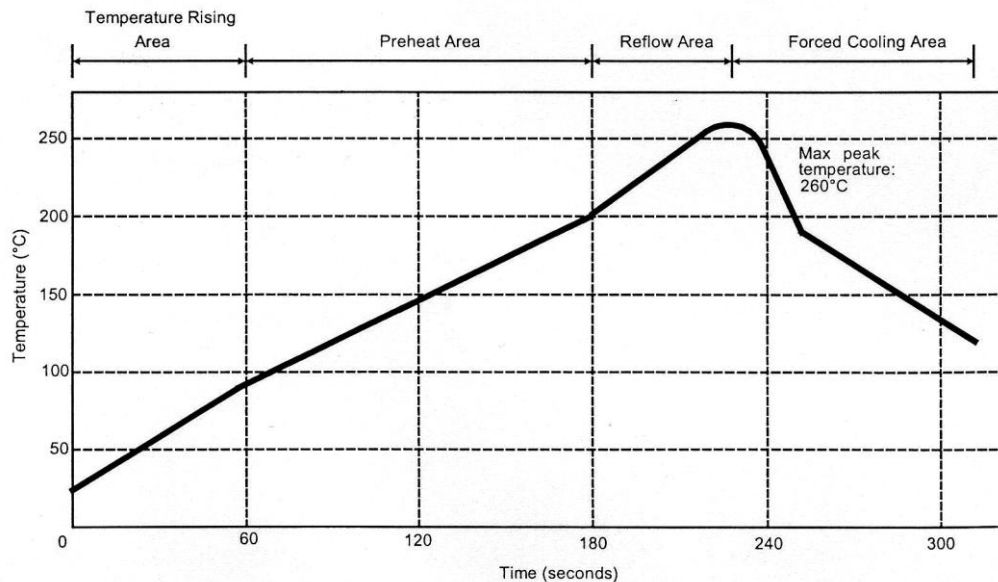

Parameter	Value	Unit
Temperature rising Area	1 - 4	°C/sec
Max Peak Temperature	260	°C
Max dwell time @260°C	10	sec
Min dwell time @235°C	20	sec
Max dwell time @235°C	60	sec
Temperature drop in cooling Area	-1 to - 4	°C/sec
Max dwell time above 100°C	420	sec

PAGE 4/5	ISSUE 1435C	SERIES MMCX	PART NUMBER R110427820
----------	-------------	-------------	------------------------

STANDARD PAD

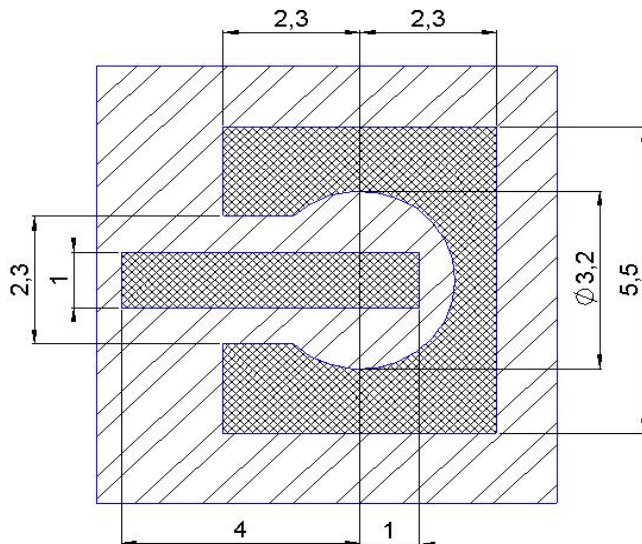

-  Masse + vernis
Ground + varnish
-  Plots de soudure
Lands for solder paste

COPLANAR LINE
 Pattern and signal are on the same side.
 Thickness of the PCB : 1.6 mm
 The material of the PCB is the epoxy resin of glass fabrics bac (ER : 4.8)
 The solder resist should be printed except for the land pattern on the PCB.

SHADOW OF RECEPTACLE FOR VIDEO CAMERA

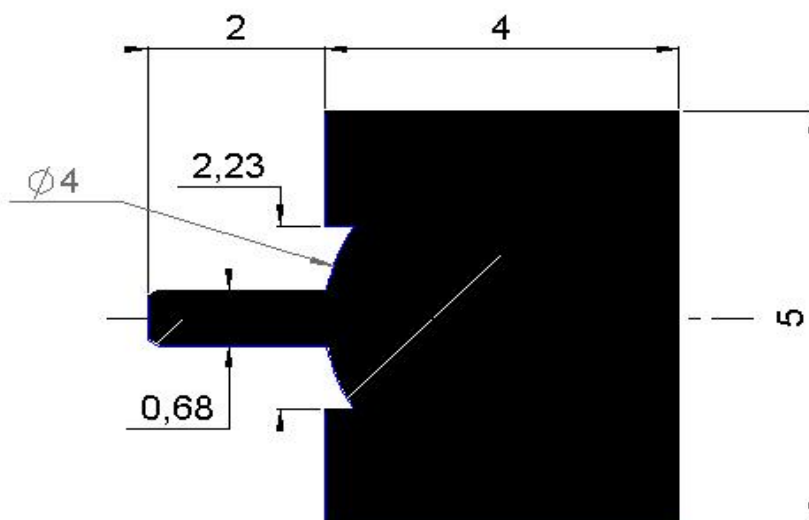

PAGE 5/5	ISSUE 1435C	SERIES MMCX	PART NUMBER R110427820
----------	-------------	-------------	------------------------

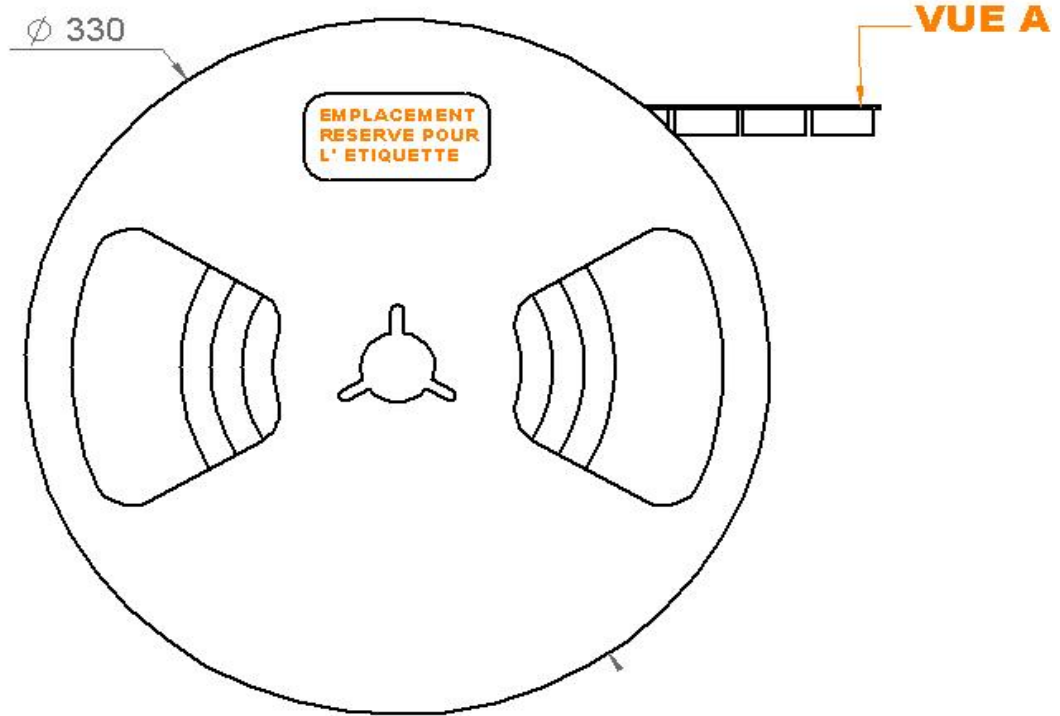

Vue A

