

# ACPL-T350

## 2.5 Amp Output Current IGBT Gate Driver Optocoupler with Low $I_{CC}$

### Data Sheet



**Lead (Pb) Free**  
RoHS 6 fully compliant

RoHS 6 fully compliant options available;  
-xxxE denotes a lead-free product

#### Description

The ACPL-T350 contains a GaAsP LED. The LED is optically coupled to an integrated circuit with a power output stage. These optocouplers are ideally suited for driving power IGBTs and MOSFETs used in motor control inverter applications. The high operating voltage range of the output stage provides the drive voltages required by gate controlled devices. The voltage and current supplied by these optocouplers make them ideally suited for directly driving IGBTs with ratings up to 1200 V/100 A. For IGBTs with higher ratings, the ACPL-T350 series can be used to drive a discrete power stage which drives the IGBT gate. The ACPL-T350 has an insulation voltage of  $V_{IORM} = 630 V_{peak}$  (Option 060).

#### Functional Diagram

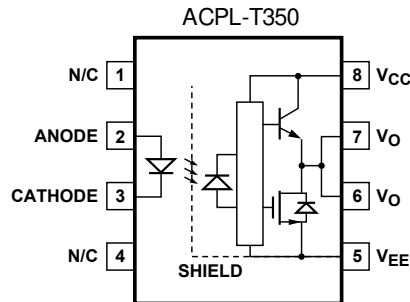

Note: A 0.1  $\mu F$  bypass capacitor must be connected between pins  $V_{CC}$  and  $V_{EE}$ .

#### UVLO Truth Table

LED	$V_{CC} - V_{EE}$ "POSITIVE GOING" (i.e., TURN-ON)	$V_{CC} - V_{EE}$ "NEGATIVE GOING" (i.e., TURN-OFF)	$V_O$
OFF	0 - 30 V	0 - 30 V	LOW
ON	0 - 11 V	0 - 9.5 V	LOW
ON	11 - 13.5 V	9.5 - 12 V	TRANSITION
ON	13.5 - 30 V	12 - 30 V	HIGH

#### Features

- 2.5A Absolute Maximum Peak Output Current
- 15 kV/ $\mu s$  minimum Common Mode Rejection (CMR) at  $V_{CM} = 1500 V$
- 1.5 V maximum low level output voltage ( $V_{OL}$ )
- $I_{CC} = 4 mA$  maximum supply current
- Under Voltage Lock-Out protection (UVLO) with hysteresis
- Wide operating  $V_{CC}$  range: 15 to 30 Volts
- 500 ns maximum switching speeds
- Industrial temperature range:  $-40^{\circ}C$  to  $100^{\circ}C$
- Safety Approval
  - UL Recognized 3750 Vrms for 1 min.
  - CSA Approval
  - IEC/EN/DIN EN 60747-5-5 Approved
- $V_{IORM} = 630 V_{peak}$  (Option 060)

#### Applications

- IGBT/MOSFET gate drive
- Inverter for Home Appliances
- Industrial Inverters
- Switching Power Supplies (SPS)

**CAUTION:** It is advised that normal static precautions be taken in handling and assembly of this component to prevent damage and/or degradation which may be induced by ESD.

## Ordering Information

ACPL-T350 is UL Recognized with 3750 Vrms for 1 minute per UL1577.

Part number	Option	Package	Surface Mount	Gull Wing	Tape& Reel	IEC/EN/DIN EN 60747-5-5	Quantity	
	RoHS Compliant							
ACPL-T350	-000E	300mil DIP-8					50 per tube	
	-300E		X	X		50 per tube		
	-500E/500ME		X	X	X		1000 per reel	
	-060E						X	50 per tube
	-360E		X	X			X	50 per tube
	-560E/560ME		X	X	X	X	X	1000 per reel

To order, choose a part number from the part number column and combine with the desired option from the option column to form an order entry.

Example 1:

ACPL-T350-560E to order product of 300mil DIP Gull Wing Surface Mount package in Tape and Reel packaging with IEC/EN/DIN EN 60747-5-5 Safety Approval in RoHS compliant.

Example 2:

ACPL-T350-000E to order product of 300mil DIP package in tube packaging and RoHS compliant.

Option datasheets are available. Contact your Avago sales representative or authorized distributor for information.

Remarks: The notation '#XXX' is used for existing products, while (new) products launched since 15th July 2001 and RoHS compliant option will use '-XXXE'.

## Regulatory Information

The ACPL-T350 is approved by the following organizations:

### IEC/EN/DIN EN 60747-5-5 (ACPL-T350 Option 060 only)

Approval under:  
DIN EN 60747-5-5 (VDE 0884-5):2011-11  
EN 60747-5-5:2011

### UL

Approval under UL 1577, component recognition program, File E55361.

### CSA

Approval under CSA Component Acceptance Notice #5, File CA 88324.

## Recommended Pb-Free IR Profile

Recommended reflow condition as per JEDEC Standard, J-STD-020 (latest revision). Non-Halide Flux should be used.

# Package Outline Drawings

## ACPL-T350 Outline Drawing

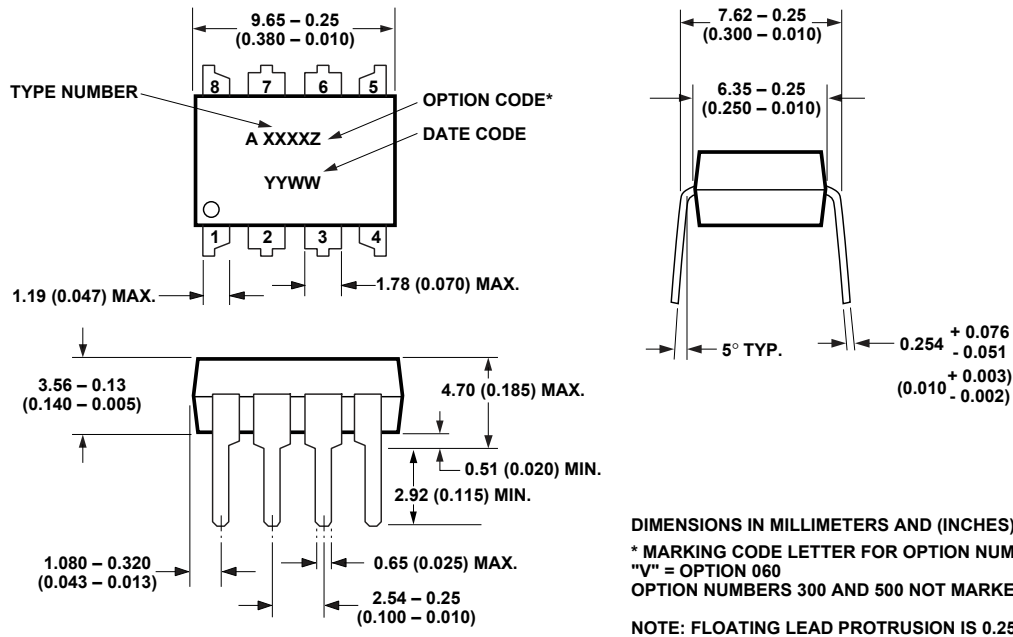

## ACPL-T350 Outline Drawing

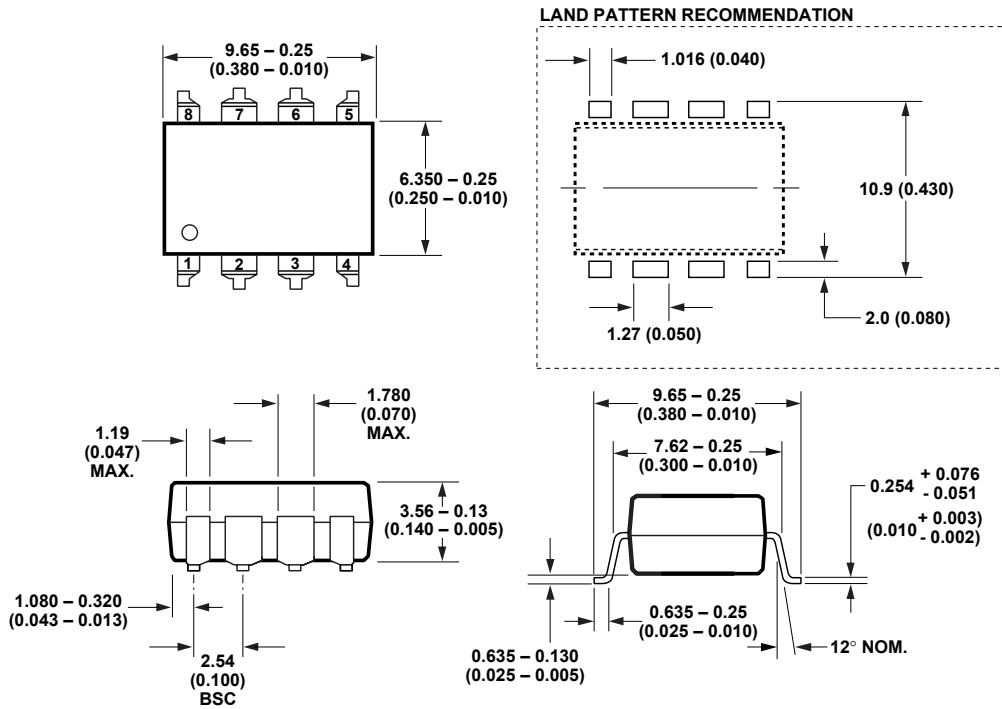
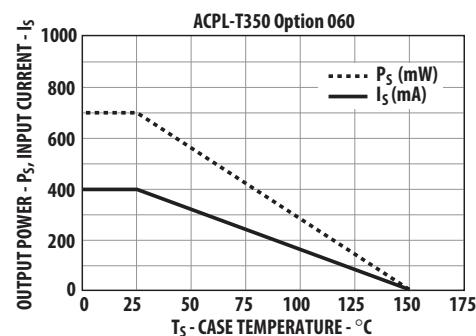

**Table 1. IEC/EN/DIN EN 60747-5-5 Insulation Characteristics\* (ACPL-T350 Option 060)**

Description	Symbol	ACPL-T350 Option 060	Unit
Installation classification per DIN VDE 0110/39, Table 1 for rated mains voltage $\leq 150 V_{rms}$ for rated mains voltage $\leq 300 V_{rms}$ for rated mains voltage $\leq 450 V_{rms}$		I – IV I – IV I – III	
Climatic Classification		55/100/21	
Pollution Degree (DIN VDE 0110/39)		2	
Maximum Working Insulation Voltage	$V_{IORM}$	630	$V_{peak}$
Input to Output Test Voltage, Method b* $V_{IORM} \times 1.875 = V_{PR}$ , 100% Production Test with $t_m = 1$ sec, Partial discharge $< 5$ pC	$V_{PR}$	1181	$V_{peak}$
Input to Output Test Voltage, Method a* $V_{IORM} \times 1.6 = V_{PR}$ , Type and Sample Test, $t_m = 10$ sec, Partial discharge $< 5$ pC	$V_{PR}$	1008	$V_{peak}$
Highest Allowable Overvoltage (Transient Overvoltage $t_{ini} = 60$ sec)	$V_{IOTM}$	6000	$V_{peak}$
Safety-limiting values – maximum values allowed in the event of a failure			
Case Temperature	$T_S$	175	$^{\circ}C$
Input Current	$I_S, INPUT$	230	mA
Output Power	$P_S, OUTPUT$	600	mW
Insulation Resistance at $T_S, V_{IO} = 500$ V	$R_S$	$> 10^9$	$\Omega$

\* Refer to the optocoupler section of the Isolation and Control Components Designer's Catalog, under Product Safety Regulations section, (IEC/EN/DIN EN 60747-5-5) for a detailed description of Method a and Method b partial discharge test profiles.

Note: These optocouplers are suitable for "safe electrical isolation" only within the safety limit data. Maintenance of the safety data shall be ensured by means of protective circuits. Surface mount classification is Class A in accordance with CECC 00802.



**Table 2. Insulation and Safety Related Specifications**

Parameter	Symbol	ACPL-T350	Units	Conditions
Minimum External Air Gap (Clearance)	L(101)	7.1	mm	Measured from input terminals to output terminals, shortest distance through air.
Minimum External Tracking (Creepage)	L(102)	7.4	mm	Measured from input terminals to output terminals, shortest distance path along body.
Minimum Internal Plastic Gap (Internal Clearance)		0.08	mm	Through insulation distance conductor to conductor, usually the straight line distance thickness between the emitter and detector.
Tracking Resistance (Comparative Tracking Index)	CTI	$> 175$	V	DIN IEC 112/VDE 0303 Part 1
Isolation Group		IIIa		Material Group (DIN VDE 0110, 1/89, Table 1)

All Avago data sheets report the creepage and clearance inherent to the optocoupler component itself. These dimensions are needed as a starting point for the equipment designer when determining the circuit insulation requirements. However, once mounted on a printed circuit board, minimum creepage and clearance requirements must be met as specified for individual equipment standards. For creepage, the shortest distance path along the surface of a printed circuit board between the solder fillets of the input and output leads must be considered (the recommended Land Pattern does not necessarily meet the minimum creepage of the device). There are recommended techniques such as grooves and ribs which may be used on a printed circuit board to achieve desired creepage and clearances. Creepage and clearance distances will also change depending on factors such as pollution degree and insulation level.

**Table 3. Absolute Maximum Ratings**

Parameter	Symbol	Min.	Max.	Units	Note
Storage Temperature	$T_S$	-55	125	°C	
Operating Temperature	$T_A$	-40	100	°C	
Average Input Current	$I_{F(AVG)}$		25	mA	1
Peak Transient Input Current ( $<1 \mu s$ pulse width, 300pps)	$I_{F(TRAN)}$		1.0	A	
Reverse Input Voltage	$V_R$		5	V	
“High” Peak Output Current	$I_{OH(PEAK)}$		2.5	A	2
“Low” Peak Output Current	$I_{OL(PEAK)}$		2.5	A	2
Supply Voltage	$V_{CC} - V_{EE}$	0	35	V	
Input Current (Rise/Fall Time)	$t_{r(IN)} / t_{f(IN)}$		500	ns	
Output Voltage	$V_{O(PEAK)}$	0	$V_{CC}$	V	
Output Power Dissipation	$P_O$		250	mW	3
Total Power Dissipation	$P_T$		295	mW	4
Lead Solder Temperature	260°C for 10 sec., 1.6 mm below seating plane				

**Table 4. Recommended Operating Conditions**

Parameter	Symbol	Min.	Max.	Units	Note
Power Supply	$V_{CC} - V_{EE}$	15	30	V	
Input Current (ON)	$I_{F(ON)}$	7	16	mA	
Input Voltage (OFF)	$V_{F(OFF)}$	-3.6	0.8	V	
$I_{OH(PEAK)} / I_{OL(PEAK)}$	$T_A$	-2.0	2.0	A	
Operating Temperature	$T_A$	-40	100	°C	

**Table 5. Electrical Specifications (DC)**

Over recommended operating conditions ( $T_A = -40$  to  $100^\circ\text{C}$ ,  $I_{F(ON)} = 7$  to  $16$  mA,  $V_{F(OFF)} = -3.6$  to  $0.8$  V,  $V_{CC} = 15$  to  $30$  V,  $V_{EE} = \text{Ground}$ ) unless otherwise specified. All typical values at  $T_A = 25^\circ\text{C}$  and  $V_{CC} - V_{EE} = 30$  V, unless otherwise noted.

Parameter	Symbol	Min.	Typ.	Max.	Units	Test Conditions	Fig.	Note
High Level Output Current	$I_{OH}$	0.5	1.6		A	$V_O = V_{CC} - 4$ V	2, 3, 15	5
		2.0			A	$V_O = V_{CC} - 15$ V		
Low Level Output Current	$I_{OL}$	0.5	1.6		A	$V_O = V_{EE} + 2.5$ V	5, 6, 16	5
		2.0			A	$V_O = V_{EE} + 15$ V		
High Level Output Voltage	$V_{OH}$	$V_{CC}-4$	$V_{CC}-3$		V	$I_O = -100$ mA	1, 3, 17	6, 7
Low Level Output Voltage	$V_{OL}$		$V_{EE}+0.5$	1.5	V	$I_O = 100$ mA	4, 6, 18	
High Level Supply Current	$I_{CCH}$		2.0	4.0	mA	Output open, $I_F = 7$ to $16$ mA	7, 8	
Low Level Supply Current	$I_{CCL}$		2.0	4.0	mA	Output open, $V_F = -3.0$ to $+0.8$ V		
Threshold Input Current Low to High	$I_{FLH}$		2.0	5	mA	$I_O = 0$ mA, $V_O > 5$ V	9, 19	
Threshold Input Voltage High to Low	$V_{FHL}$	0.8			V	$I_O = 0$ mA, $V_O > 5$ V		
Input Forward Voltage	$V_F$	1.2	1.5	1.8	V	$I_F = 10$ mA		
Temperature Coefficient of Input Forward Voltage	$\Delta V_F/\Delta T_A$		-2.0		mV/ $^\circ\text{C}$	$I_F = 10$ mA		
Input Reverse Breakdown Voltage	$BV_R$	5			V	$I_R = 10$ $\mu\text{A}$		
Input Capacitance	$C_{IN}$		60		pF	$f = 1$ MHz, $V_F = 0$ V		
UVLO Threshold	$V_{UVLO+}$	11.0	12.3	13.5	V	$I_F = 10$ mA, $V_O > 5$ V	14, 20	
	$V_{UVLO-}$	9.5	10.7	12.0	V	$I_F = 10$ mA, $V_O > 5$ V		
UVLO Hysteresis	$UVLO_{HYS}$		1.6		V	$I_F = 10$ mA, $V_O > 5$ V		

**Table 6. Switching Specifications (AC)**

Over recommended operating conditions ( $T_A = -40$  to  $100^\circ\text{C}$ ,  $I_{F(ON)} = 7$  to  $16$  mA,  $V_{F(OFF)} = -3.6$  to  $0.8$  V,  $V_{CC} = 15$  to  $30$  V,  $V_{EE} = \text{Ground}$ ) unless otherwise specified. All typical values at  $T_A = 25^\circ\text{C}$  and  $V_{CC} - V_{EE} = 30$  V, unless otherwise noted.

Parameter	Symbol	Min.	Typ.	Max.	Units	Test Conditions	Fig.	Note
Propagation Delay Time to High Output Level	$t_{PLH}$	0.05	0.25	0.5	$\mu\text{s}$	$R_g = 10$ $\Omega$ , $C_g = 10$ nF, $f = 10$ kHz, Duty Cycle = 50%	10, 11, 12, 21	8
Propagation Delay Time to Low Output Level	$t_{PHL}$	0.05	0.25	0.5	$\mu\text{s}$			
Pulse Width Distortion	PWD			0.3	$\mu\text{s}$			9
Propagation Delay Difference Between Any Two Parts or Channels	PDD ( $t_{PHL} - t_{PLH}$ )	-0.35		0.35	$\mu\text{s}$			10
Rise Time	$t_R$		15		ns		21	
Fall Time	$t_F$		20		ns			
Output High Level Common Mode Transient Immunity	$ CM_H $	15	20		kV/ $\mu\text{s}$	$T_A = 25^\circ\text{C}$ , $I_F = 10$ to $16$ mA, $V_{CM} = 1500$ V, $V_{CC} = 30$ V	22	11, 12
Output Low Level Common Mode Transient Immunity	$ CM_L $	15	20		kV/ $\mu\text{s}$	$T_A = 25^\circ\text{C}$ , $V_F = 0$ V, $V_{CM} = 1500$ V, $V_{CC} = 30$ V	22	11, 13

**Table 7. Package Characteristics**

Over recommended temperature ( $T_A = -40$  to  $100^\circ\text{C}$ ) unless otherwise specified. All typicals at  $T_A = 25^\circ\text{C}$ .

Parameter	Symbol	Min.	Typ.	Max.	Units	Test Conditions	Fig.	Note
Input-Output Momentary Withstand Voltage**	$V_{ISO}$	3750			Vrms	RH < 50%, t = 1 min., $T_A = 25^\circ\text{C}$		14, 15
Resistance Input-Output)	$R_{I-O}$		$10^{12}$		$\Omega$	$V_{I-O} = 500\text{ V}$		15
Capacitance Input-Output)	$C_{I-O}$		0.6		pF	Freq=1 MHz		
LED-to-Case Thermal Resistance	$\theta_{LC}$		467		$^\circ\text{C}/\text{W}$	Thermocouple located at center underside of package		
LED-to-Detector Thermal Resistance	$\theta_{LD}$		442		$^\circ\text{C}/\text{W}$			
Detector-to-Case Thermal Resistance	$\theta_{DC}$		126		$^\circ\text{C}/\text{W}$			

\*\* The Input-Output Momentary Withstand Voltage is a dielectric voltage rating that should not be interpreted as an input-output continuous voltage rating. For the continuous voltage rating refers to your equipment level safety specification or Avago Application Note 1074 entitled "Optocoupler Input-Output Endurance Voltage."

Notes:

1. Derate linearly above  $70^\circ\text{C}$  free-air temperature at a rate of  $0.3\text{ mA}/^\circ\text{C}$ .
2. Maximum pulse width =  $10\ \mu\text{s}$ .
3. Derate linearly above  $70^\circ\text{C}$  free-air temperature at a rate of  $4.8\text{ mW}/^\circ\text{C}$ .
4. Derate linearly above  $70^\circ\text{C}$  free-air temperature at a rate of  $5.4\text{ mW}/^\circ\text{C}$ . The maximum LED junction temperature should not exceed  $125^\circ\text{C}$ .
5. Maximum pulse width =  $50\ \mu\text{s}$
6. In this test  $V_{OH}$  is measured with a dc load current. When driving capacitive loads  $V_{OH}$  will approach  $V_{CC}$  as  $I_{OH}$  approaches zero amps.
7. Maximum pulse width =  $1\text{ ms}$
8. This load condition approximates the gate load of a  $1200\text{ V}/100\text{A}$  IGBT.
9. Pulse Width Distortion (PWD) is defined as  $|t_{PHL} - t_{PLH}|$  for any given device.
10. The difference between  $t_{PHL}$  and  $t_{PLH}$  between any two ACPL-T350 parts under the same test condition.
11. Pins 1 and 4 need to be connected to LED common.
12. Common mode transient immunity in the high state is the maximum tolerable  $dV_{CM}/dt$  of the common mode pulse,  $V_{CM}$ , to assure that the output will remain in the high state (i.e.,  $V_O > 15.0\text{ V}$ ).
13. Common mode transient immunity in a low state is the maximum tolerable  $dV_{CM}/dt$  of the common mode pulse,  $V_{CM}$ , to assure that the output will remain in a low state (i.e.,  $V_O < 2.0\text{ V}$ ).
14. In accordance with UL1577, each optocoupler is proof tested by applying an insulation test voltage  $\geq 4500\text{ Vrms}$  for 1 second (leakage detection current limit,  $I_{I-O} \leq 5\ \mu\text{A}$ ).
15. Device considered a two-terminal device: pins 1, 2, 3, and 4 shorted together and pins 5, 6, 7, and 8 shorted together.

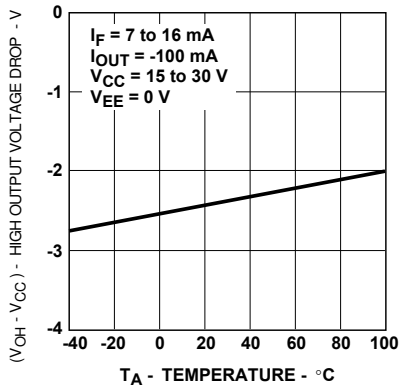

Figure 1.  $V_{OH}$  vs. temperature.

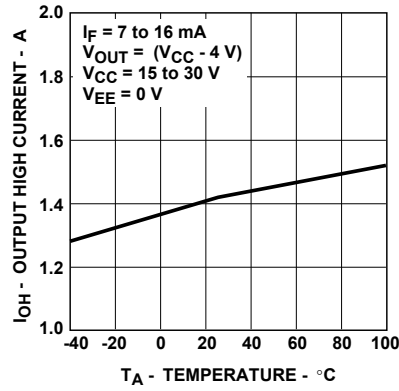

Figure 2.  $I_{OH}$  vs. temperature.

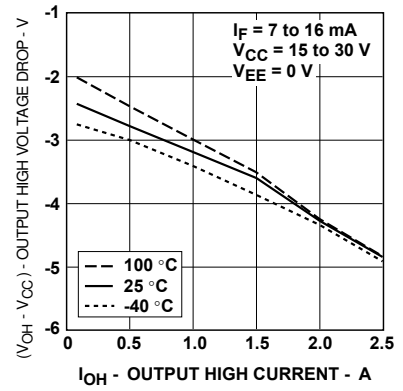

Figure 3.  $V_{OH}$  vs.  $I_{OH}$ .

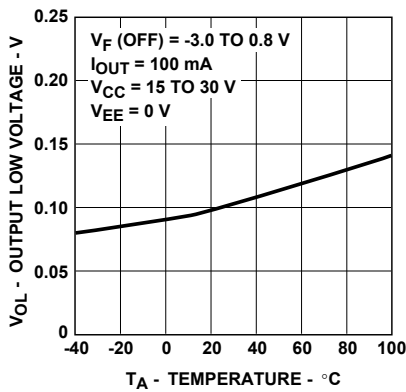

Figure 4.  $V_{OL}$  vs. temperature.

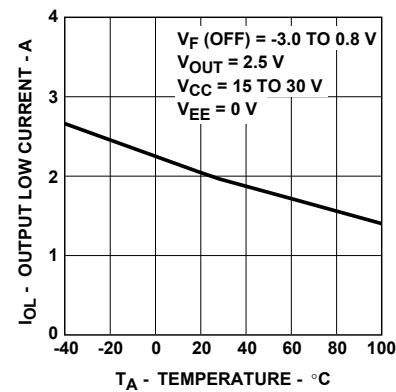

Figure 5.  $I_{OL}$  vs. temperature.

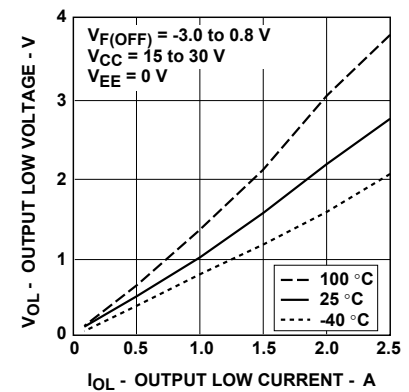

Figure 6.  $V_{OL}$  vs.  $I_{OL}$ .

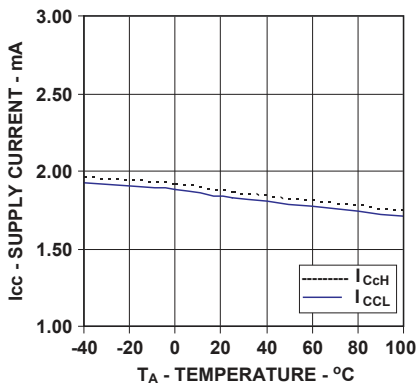

Figure 7.  $I_{CC}$  vs. Temperature

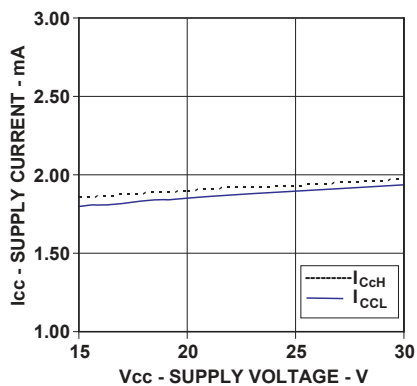

Figure 8.  $I_{CC}$  vs.  $V_{CC}$



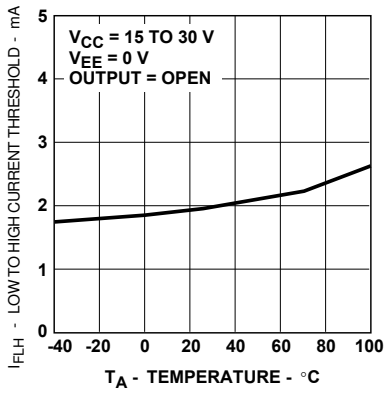

Figure 9.  $I_{FLH}$  vs. temperature.

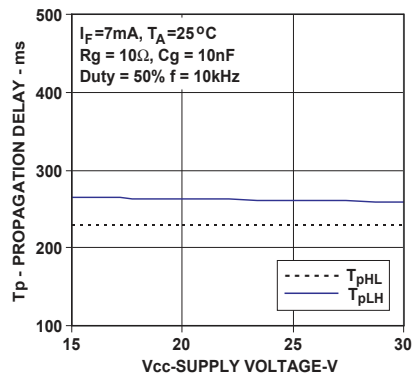

Figure 10. Propagation delay vs.  $V_{CC}$ .

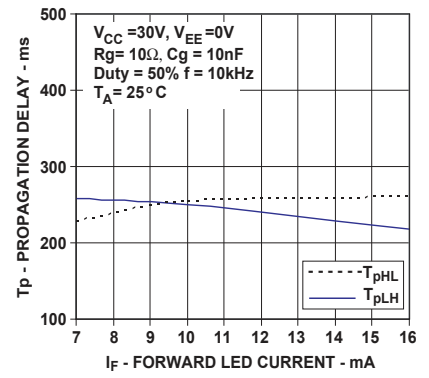

Figure 11. Propagation delay vs.  $I_F$ .

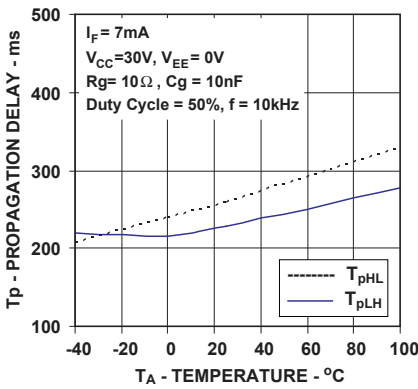

Figure 12. Propagation delay vs. Temperature

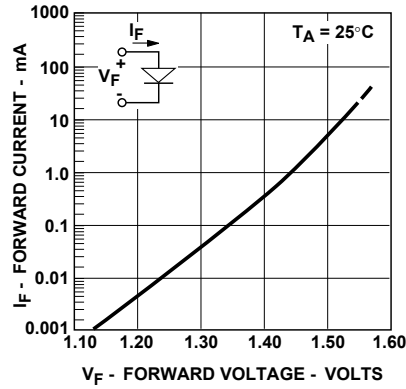

Figure 13. Input current vs. forward voltage.

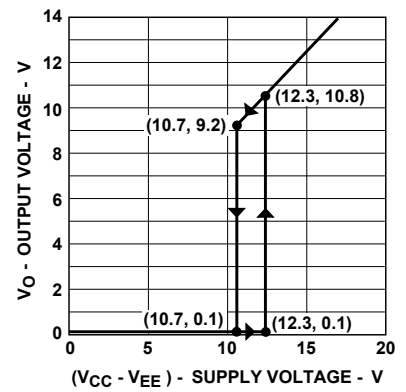

Figure 14. Under voltage lock out.

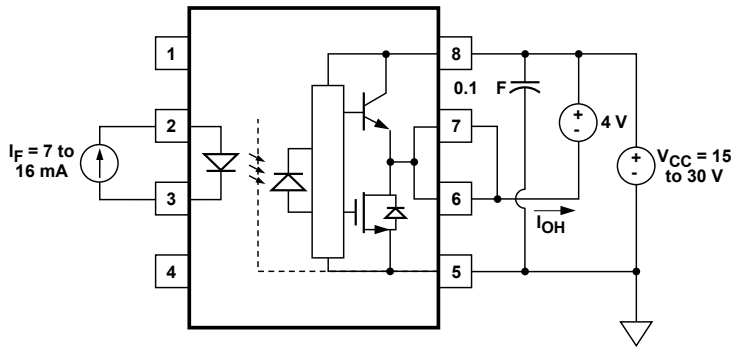

Figure 15.  $I_{OH}$  test circuit.

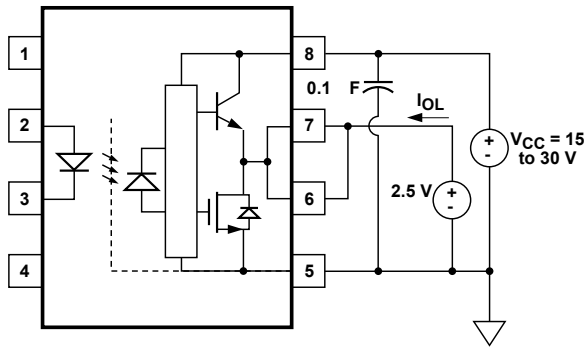

Figure 16.  $I_{OL}$  Test circuit.

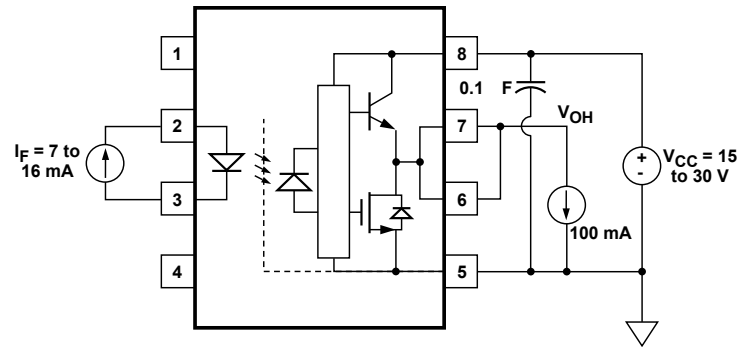

Figure 17.  $V_{OH}$  Test circuit.

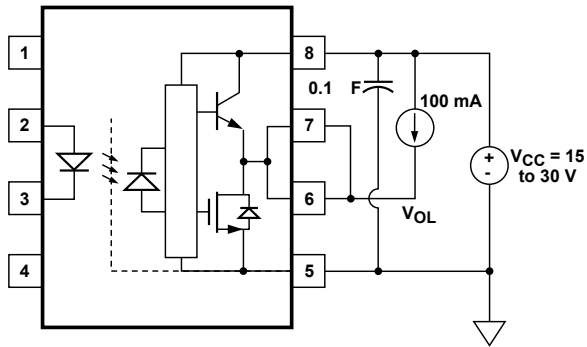

Figure 18.  $V_{OL}$  Test circuit.

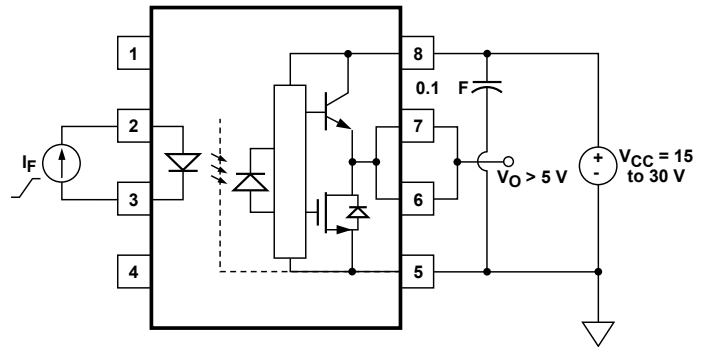

Figure 19.  $I_{FLH}$  Test circuit.

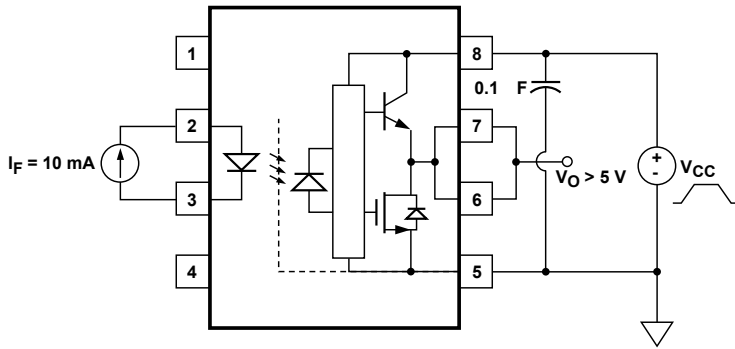

Figure 20. UVLO Test Circuit

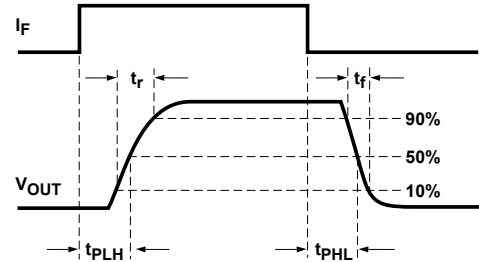
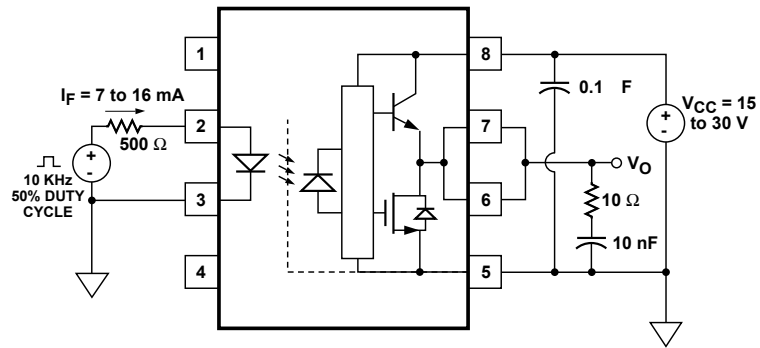

Figure 21.  $t_{PLH}$ ,  $t_{PHL}$ ,  $t_r$ , and  $t_f$  test circuit and waveforms.

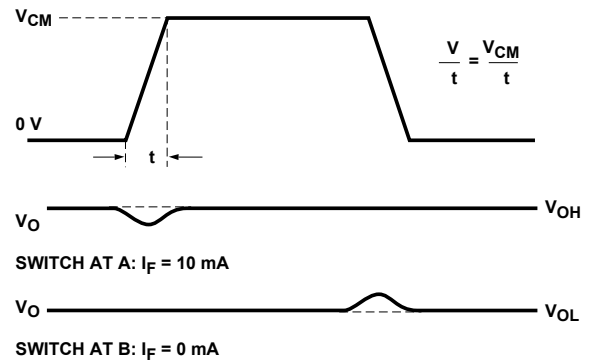
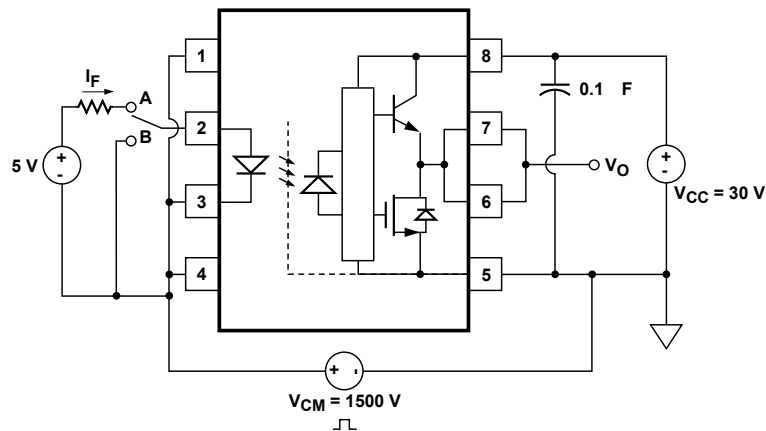

Figure 22. CMR test circuit and waveforms.

## Typical Application Circuit

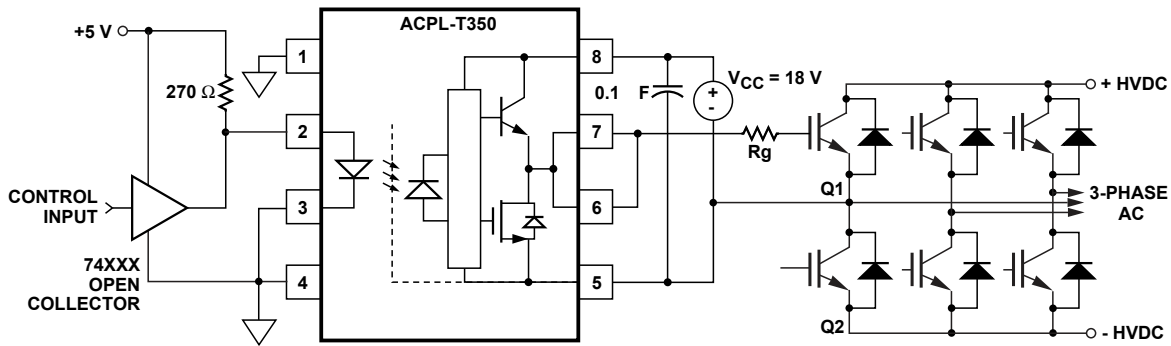

Figure 23. Recommended LED drive and application circuit.

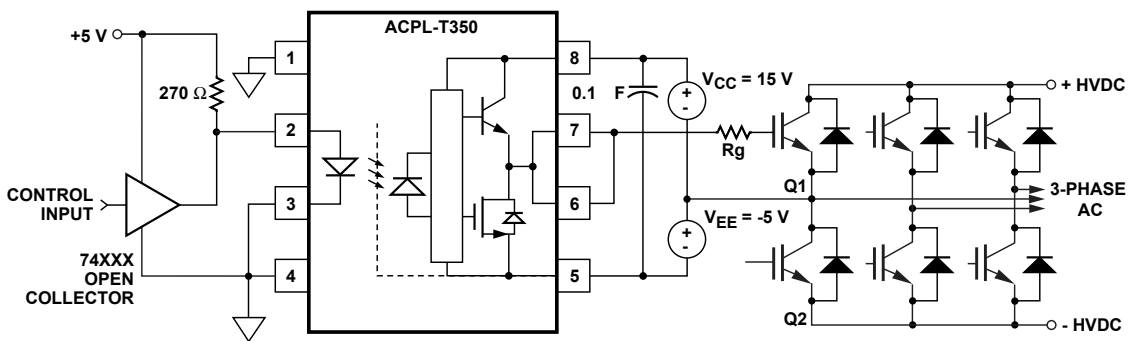

Figure 24. Typical application circuit with negative IGBT gate drive.

For product information and a complete list of distributors, please go to our web site: [www.avagotech.com](http://www.avagotech.com)

Avago, Avago Technologies, and the A logo are trademarks of Avago Technologies, Limited in the United States and other countries. Data subject to change. Copyright © 2012-2016 Avago Technologies Limited. All rights reserved. AV02-0308EN - September 23, 2016

**Avago**  
TECHNOLOGIES  
A Broadcom Limited Company