

FEATURES

- Latch-up proof
- 2.9 pF off source capacitance
- 34 pF off drain capacitance
- 0.2 pC charge injection
- Low on resistance: 160 Ω typical
- ± 9 V to ± 22 V dual-supply operation
- 9 V to 40 V single-supply operation
- 48 V supply maximum ratings
- Fully specified at ± 15 V, ± 20 V, +12 V, and +36 V
- V_{SS} to V_{DD} analog signal range
- Human body model (HBM) ESD rating
 - 8 kV I/O port to supplies
 - 2 kV I/O port to I/O port
 - 8 kV all other pins

APPLICATIONS

- Automatic test equipment
- Data acquisition
- Instrumentation
- Avionics
- Audio and video switching
- Communication systems

GENERAL DESCRIPTION

The [ADG5208/ADG5209](#) are monolithic CMOS analog multiplexers comprising eight single channels and four differential channels, respectively. The [ADG5208](#) switches one of eight inputs to a common output, as determined by the 3-bit binary address lines, A0, A1, and A2. The [ADG5209](#) switches one of four differential inputs to a common differential output, as determined by the 2-bit binary address lines, A0 and A1.

An EN input on both devices enables or disables the device. When EN is disabled, all channels switch off. The ultralow capacitance and charge injection of these switches make them ideal solutions for data acquisition and sample-and-hold applications, where low glitch and fast settling are required. Fast switching speed coupled with high signal bandwidth make these devices suitable for video signal switching.

Each switch conducts equally well in both directions when on, and each switch has an input signal range that extends to the power supplies. In the off condition, signal levels up to the supplies are blocked.

FUNCTIONAL BLOCK DIAGRAMS

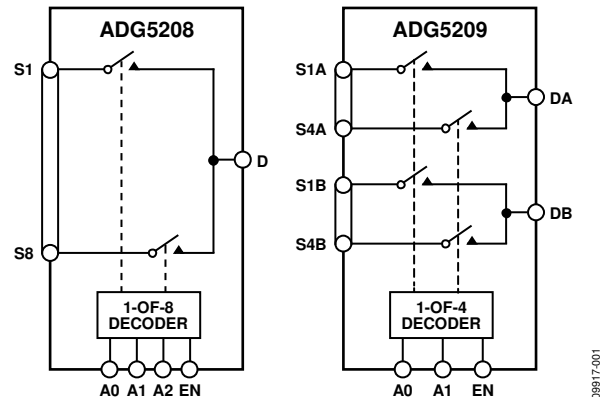

Figure 1.

The [ADG5208/ADG5209](#) do not have V_L pins; instead, the logic power supply is generated internally by an on-chip voltage generator.

PRODUCT HIGHLIGHTS

1. Trench Isolation Guards Against Latch-Up.
A dielectric trench separates the P and N channel transistors to prevent latch-up even under severe overvoltage conditions.
2. 0.2 pC Charge Injection.
3. Dual-Supply Operation.
For applications where the analog signal is bipolar, the [ADG5208/ADG5209](#) can be operated from dual supplies of up to ± 22 V.
4. Single-Supply Operation.
For applications where the analog signal is unipolar, the [ADG5208/ADG5209](#) can be operated from a single rail power supply of up to 40 V.
5. 3 V Logic-Compatible Digital Inputs.
 $V_{INH} = 2.0$ V, $V_{INL} = 0.8$ V.
6. No V_L Logic Power Supply Required.

Rev. C

[Document Feedback](#)

Information furnished by Analog Devices is believed to be accurate and reliable. However, no responsibility is assumed by Analog Devices for its use, nor for any infringements of patents or other rights of third parties that may result from its use. Specifications subject to change without notice. No license is granted by implication or otherwise under any patent or patent rights of Analog Devices. Trademarks and registered trademarks are the property of their respective owners.

TABLE OF CONTENTS

Features	1	Absolute Maximum Ratings	9
Applications.....	1	ESD Caution.....	9
Functional Block Diagrams.....	1	Pin Configurations and Function Descriptions	10
General Description	1	Typical Performance Characteristics	12
Product Highlights	1	Test Circuits.....	16
Revision History	2	Terminology	19
Specifications.....	3	Trench Isolation.....	20
±15 V Dual Supply	3	Applications Information	21
±20 V Dual Supply	4	Outline Dimensions	22
12 V Single Supply.....	5	Ordering Guide	22
36 V Single Supply.....	6		
Continuous Current per Channel, Sx, D, or Dx.....	8		

REVISION HISTORY

8/15—Rev. B to Rev. C

Changes to Features Section.....	1
Changes to Table 1.....	3
Changes to Table 2.....	4
Changes to Table 3.....	5
Changes to Table 4.....	6
Changes to Table 7.....	9
Changes to Figure 18 Caption to Figure 23 Caption	14
Changes to Figure 24 Caption to Figure 26 Caption	15
Deleted Figure 21, Figure 22, and Figure 23; Renumbered Sequentially	16
Deleted Figure 27, Figure 28, and Figure 29	17
Deleted Figure 33, Figure 34, and Figure 35	18

12/14—Rev. A to Rev. B

Changes to Features and Product Highlights	1
Changes to Table 1.....	3
Changes to Table 2.....	4
Changes to Table 3.....	6
Changes to Table 4.....	8
Changes to HBM ESD, Table 7	11
Changes to Typical Performance Characteristics Section.....	14
Changes to Figure 36, Figure 37, and Figure 39	19

3/12—Rev. 0 to Rev. A

Added 16-Lead LFCSP.....	Universal
Changes to Ordering Guide	22

7/11—Revision 0: Initial Version

SPECIFICATIONS

±15 V DUAL SUPPLY

$V_{DD} = +15\text{ V} \pm 10\%$, $V_{SS} = -15\text{ V} \pm 10\%$, $GND = 0\text{ V}$, unless otherwise noted.

Table 1.

Parameter	25°C	-40°C to +85°C	-40°C to +125°C	Unit	Test Conditions/Comments
ANALOG SWITCH					
Analog Signal Range			V_{DD} to V_{SS}	V	
On Resistance, R_{ON}	160			Ω typ	$V_S = \pm 10\text{ V}$, $I_S = -1\text{ mA}$; see Figure 28
	200	250	280	Ω max	$V_{DD} = +13.5\text{ V}$, $V_{SS} = -13.5\text{ V}$
On-Resistance Match Between Channels, ΔR_{ON}	3.5			Ω typ	$V_S = \pm 10\text{ V}$, $I_S = -1\text{ mA}$
	8	9	10	Ω max	
On-Resistance Flatness, $R_{FLAT(ON)}$	40			Ω typ	$V_S = \pm 10\text{ V}$, $I_S = -1\text{ mA}$
	50	65	70	Ω max	
LEAKAGE CURRENTS					
Source Off Leakage, I_S (Off)	± 0.005			nA typ	$V_{DD} = +16.5\text{ V}$, $V_{SS} = -16.5\text{ V}$
	± 0.1	± 0.2	± 0.4	nA max	$V_S = \pm 10\text{ V}$, $V_D = \mp 10\text{ V}$; see Figure 30
Drain Off Leakage, I_D (Off)	± 0.005			nA typ	$V_S = \pm 10\text{ V}$, $V_D = \mp 10\text{ V}$; see Figure 30
	± 0.1	± 0.4	± 1.4	nA max	
Channel On Leakage, I_D (On), I_S (On)	± 0.01			nA typ	$V_S = V_D = \pm 10\text{ V}$; see Figure 27
	± 0.2	± 0.5	± 1.4	nA max	
DIGITAL INPUTS					
Input High Voltage, V_{INH}			2.0	V min	
Input Low Voltage, V_{INL}			0.8	V max	
Input Current, I_{INL} or I_{INH}	0.002			μA typ	$V_{IN} = V_{GND}$ or V_{DD}
			± 0.1	μA max	
Digital Input Capacitance, C_{IN}	3			pF typ	
DYNAMIC CHARACTERISTICS ¹					
Transition Time, $t_{TRANSITION}$	150			ns typ	$R_L = 300\ \Omega$, $C_L = 35\text{ pF}$
	180	210	245	ns max	$V_S = 10\text{ V}$; see Figure 33
t_{ON} (EN)	125			ns typ	$R_L = 300\ \Omega$, $C_L = 35\text{ pF}$
	150	185	215	ns max	$V_S = 10\text{ V}$; see Figure 35
t_{OFF} (EN)	160			ns typ	$R_L = 300\ \Omega$, $C_L = 35\text{ pF}$
	185	210	230	ns max	$V_S = 10\text{ V}$; see Figure 35
Break-Before-Make Time Delay, t_D	55			ns typ	$R_L = 300\ \Omega$, $C_L = 35\text{ pF}$
			25	ns min	$V_{S1} = V_{S2} = 10\text{ V}$; see Figure 34
Charge Injection, Q_{INU}	0.2			pC typ	$V_S = 0\text{ V}$, $R_S = 0\ \Omega$, $C_L = 1\text{ nF}$; see Figure 36
Off Isolation	-86			dB typ	$R_L = 50\ \Omega$, $C_L = 5\text{ pF}$, $f = 1\text{ MHz}$; see Figure 31
Channel-to-Channel Crosstalk	-80			dB typ	$R_L = 50\ \Omega$, $C_L = 5\text{ pF}$, $f = 1\text{ MHz}$; see Figure 29
-3 dB Bandwidth					$R_L = 50\ \Omega$, $C_L = 5\text{ pF}$; see Figure 32
ADG5208	110			MHz typ	
ADG5209	240			MHz typ	
Insertion Loss	-6.4			dB typ	$R_L = 50\ \Omega$, $C_L = 5\text{ pF}$, $f = 1\text{ MHz}$; see Figure 32
C_S (Off)	2.9			pF typ	$V_S = 0\text{ V}$, $f = 1\text{ MHz}$
C_D (Off)					
ADG5208	34			pF typ	$V_S = 0\text{ V}$, $f = 1\text{ MHz}$
ADG5209	17			pF typ	$V_S = 0\text{ V}$, $f = 1\text{ MHz}$
C_D (On), C_S (On)					
ADG5208	37			pF typ	$V_S = 0\text{ V}$, $f = 1\text{ MHz}$
ADG5209	21			pF typ	$V_S = 0\text{ V}$, $f = 1\text{ MHz}$

Parameter	25°C	-40°C to +85°C	-40°C to +125°C	Unit	Test Conditions/Comments
POWER REQUIREMENTS					
I_{DD}	45			$\mu\text{A typ}$	$V_{DD} = +16.5\text{ V}$, $V_{SS} = -16.5\text{ V}$
	55		70	$\mu\text{A max}$	Digital inputs = 0 V or V_{DD}
I_{SS}	0.001			$\mu\text{A typ}$	Digital inputs = 0 V or V_{DD}
			1	$\mu\text{A max}$	
V_{DD}/V_{SS}			$\pm 9/\pm 22$	V min/V max	GND = 0 V

¹ Guaranteed by design; not subject to production test.

±20 V DUAL SUPPLY

$V_{DD} = +20\text{ V} \pm 10\%$, $V_{SS} = -20\text{ V} \pm 10\%$, GND = 0 V, unless otherwise noted.

Table 2.

Parameter	25°C	-40°C to +85°C	-40°C to +125°C	Unit	Test Conditions/Comments
ANALOG SWITCH					
Analog Signal Range			V_{DD} to V_{SS}	V	
On Resistance, R_{ON}	140			Ω typ	$V_S = \pm 15\text{ V}$, $I_S = -1\text{ mA}$; see Figure 28
	160	200	230	Ω max	$V_{DD} = +18\text{ V}$, $V_{SS} = -18\text{ V}$
On-Resistance Match Between Channels, ΔR_{ON}	3.5			Ω typ	$V_S = \pm 15\text{ V}$, $I_S = -1\text{ mA}$
	8	9	10	Ω max	
On-Resistance Flatness, $R_{FLAT(ON)}$	34			Ω typ	$V_S = \pm 15\text{ V}$, $I_S = -1\text{ mA}$
	45	55	60	Ω max	
LEAKAGE CURRENTS					
Source Off Leakage, I_S (Off)	± 0.005			nA typ	$V_{DD} = +22\text{ V}$, $V_{SS} = -22\text{ V}$
	± 0.1	± 0.2	± 0.4	nA max	$V_S = \pm 15\text{ V}$, $V_D = \mp 15\text{ V}$; see Figure 30
Drain Off Leakage, I_D (Off)	± 0.005			nA typ	$V_S = \pm 15\text{ V}$, $V_D = \mp 15\text{ V}$; see Figure 30
	± 0.1	± 0.4	± 1.4	nA max	
Channel On Leakage, I_D (On), I_S (On)	± 0.01			nA typ	$V_S = V_D = \pm 15\text{ V}$; see Figure 27
	± 0.2	± 0.5	± 1.4	nA max	
DIGITAL INPUTS					
Input High Voltage, V_{INH}			2.0	V min	
Input Low Voltage, V_{INL}			0.8	V max	
Input Current, I_{INL} or I_{INH}	0.002			$\mu\text{A typ}$	$V_{IN} = V_{GND}$ OR V_{DD}
			± 0.1	$\mu\text{A max}$	
Digital Input Capacitance, C_{IN}	3			pF typ	
DYNAMIC CHARACTERISTICS¹					
Transition Time, $t_{TRANSITION}$	140			ns typ	$R_L = 300\ \Omega$, $C_L = 35\text{ pF}$
	170	195	220	ns max	$V_S = 10\text{ V}$; see Figure 33
t_{ON} (EN)	120			ns typ	$R_L = 300\ \Omega$, $C_L = 35\text{ pF}$
	140	170	195	ns max	$V_S = 10\text{ V}$; see Figure 35
t_{OFF} (EN)	160			ns typ	$R_L = 300\ \Omega$, $C_L = 35\text{ pF}$
	185	205	220	ns max	$V_S = 10\text{ V}$; see Figure 35
Break-Before-Make Time Delay, t_D	45			ns typ	$R_L = 300\ \Omega$, $C_L = 35\text{ pF}$
			20	ns min	$V_{S1} = V_{S2} = 10\text{ V}$; see Figure 34
Charge Injection, Q_{INU}	0.4			pC typ	$V_S = 0\text{ V}$, $R_S = 0\ \Omega$, $C_L = 1\text{ nF}$; see Figure 36
Off Isolation	-86			dB typ	$R_L = 50\ \Omega$, $C_L = 5\text{ pF}$, $f = 1\text{ MHz}$; see Figure 31
Channel-to-Channel Crosstalk	-80			dB typ	$R_L = 50\ \Omega$, $C_L = 5\text{ pF}$, $f = 1\text{ MHz}$; see Figure 29
-3 dB Bandwidth					$R_L = 50\ \Omega$, $C_L = 5\text{ pF}$; see Figure 32
ADG5208	121			MHz typ	
ADG5209	225			MHz typ	
Insertion Loss	-5.6			dB typ	$R_L = 50\ \Omega$, $C_L = 5\text{ pF}$, $f = 1\text{ MHz}$; see Figure 32

Parameter	25°C	−40°C to +85°C	−40°C to +125°C	Unit	Test Conditions/Comments
C _S (Off)	2.8			pF typ	V _S = 0 V, f = 1 MHz
C _D (Off)					
ADG5208	33			pF typ	V _S = 0 V, f = 1 MHz
ADG5209	17			pF typ	V _S = 0 V, f = 1 MHz
C _D (On), C _S (On)					
ADG5208	36			pF typ	V _S = 0 V, f = 1 MHz
ADG5209	21			pF typ	V _S = 0 V, f = 1 MHz
POWER REQUIREMENTS					
I _{DD}	50			μA typ	V _{DD} = +22 V, V _{SS} = −22 V
	70		110	μA max	Digital inputs = 0 V or V _{DD}
I _{SS}	0.001			μA typ	Digital inputs = 0 V or V _{DD}
			1	μA max	
V _{DD} /V _{SS}			±9/±22	V min/V max	GND = 0 V

¹ Guaranteed by design; not subject to production test.

12 V SINGLE SUPPLY

V_{DD} = 12 V ± 10%, V_{SS} = 0 V, GND = 0 V, unless otherwise noted.

Table 3.

Parameter	25°C	−40°C to +85°C	−40°C to +125°C	Unit	Test Conditions/Comments
ANALOG SWITCH					
Analog Signal Range			0 V to V _{DD}	V	
On Resistance, R _{ON}	350			Ω typ	V _S = 0 V to 10 V, I _S = −1 mA; see Figure 28
	500	610	700	Ω max	V _{DD} = 10.8 V, V _{SS} = 0 V
On-Resistance Match Between Channels, ΔR _{ON}	5			Ω typ	V _S = 0 V to 10 V, I _S = −1 mA
	20	22	24	Ω max	
On-Resistance Flatness, R _{FLAT (ON)}	160			Ω typ	V _S = 0 V to 10 V, I _S = −1 mA
	280	335	370	Ω max	
LEAKAGE CURRENTS					
Source Off Leakage, I _S (Off)	±0.005			nA typ	V _{DD} = 13.2 V, V _{SS} = 0 V
	±0.1	±0.2	±0.4	nA max	V _S = 1 V/10 V, V _D = 10 V/1 V; see Figure 30
Drain Off Leakage, I _D (Off)	±0.005			nA typ	V _S = 1 V/10 V, V _D = 10 V/1 V; see Figure 30
	±0.1	±0.4	±1.4	nA max	
Channel On Leakage, I _D (On), I _S (On)	±0.01			nA typ	V _S = V _D = 1 V/10 V; see Figure 27
	±0.2	±0.5	±1.4	nA max	
DIGITAL INPUTS					
Input High Voltage, V _{INH}			2.0	V min	
Input Low Voltage, V _{INL}			0.8	V max	
Input Current, I _{INL} or I _{INH}	0.002			μA typ	V _{IN} = V _{GND} OR V _{DD}
			±0.1	μA max	
Digital Input Capacitance, C _{IN}	3			pF typ	
DYNAMIC CHARACTERISTICS¹					
Transition Time, t _{TRANSITION}	200			ns typ	R _L = 300 Ω, C _L = 35 pF
	250	295	335	ns max	V _S = 8 V; see Figure 33
t _{ON} (EN)	180			ns typ	R _L = 300 Ω, C _L = 35 pF
	225	280	320	ns max	V _S = 8 V; see Figure 35
t _{OFF} (EN)	165			ns typ	R _L = 300 Ω, C _L = 35 pF
	200	225	245	ns max	V _S = 8 V; see Figure 35
Break-Before-Make Time Delay, t _b	95			ns typ	R _L = 300 Ω, C _L = 35 pF
			50	ns min	V _{S1} = V _{S2} = 8 V; see Figure 34
Charge Injection, Q _{INU}	0.2			pC typ	V _S = 6 V, R _S = 0 Ω, C _L = 1 nF; see Figure 36

Parameter	25°C	-40°C to +85°C	-40°C to +125°C	Unit	Test Conditions/Comments
Off Isolation	-86			dB typ	$R_L = 50 \Omega$, $C_L = 5 \text{ pF}$, $f = 1 \text{ MHz}$; see Figure 31
Channel-to-Channel Crosstalk	-80			dB typ	$R_L = 50 \Omega$, $C_L = 5 \text{ pF}$, $f = 1 \text{ MHz}$; see Figure 29
-3 dB Bandwidth					$R_L = 50 \Omega$, $C_L = 5 \text{ pF}$; see Figure 32
ADG5208	95			MHz typ	
ADG5209	180			MHz typ	
Insertion Loss	-8.9			dB typ	$R_L = 50 \Omega$, $C_L = 5 \text{ pF}$, $f = 1 \text{ MHz}$; see Figure 32
C_S (Off)	3.3			pF typ	$V_S = 6 \text{ V}$, $f = 1 \text{ MHz}$
C_D (Off)					
ADG5208	38			pF typ	$V_S = 6 \text{ V}$, $f = 1 \text{ MHz}$
ADG5209	19			pF typ	$V_S = 6 \text{ V}$, $f = 1 \text{ MHz}$
C_D (On), C_S (On)					
ADG5208	41			pF typ	$V_S = 6 \text{ V}$, $f = 1 \text{ MHz}$
ADG5209	24			pF typ	$V_S = 6 \text{ V}$, $f = 1 \text{ MHz}$
POWER REQUIREMENTS					
I_{DD}	40			μA typ	$V_{DD} = 13.2 \text{ V}$
	50		65	μA max	Digital inputs = 0 V or V_{DD}
V_{DD}			9/40	V min/V max	$GND = 0 \text{ V}$, $V_{SS} = 0 \text{ V}$

¹ Guaranteed by design; not subject to production test.

36 V SINGLE SUPPLY

$V_{DD} = 36 \text{ V} \pm 10\%$, $V_{SS} = 0 \text{ V}$, $GND = 0 \text{ V}$, unless otherwise noted.

Table 4.

Parameter	25°C	-40°C to +85°C	-40°C to +125°C	Unit	Test Conditions/Comments
ANALOG SWITCH					
Analog Signal Range			0 V to V_{DD}	V	
On Resistance, R_{ON}	150			Ω typ	$V_S = 0 \text{ V}$ to 30 V, $I_S = -1 \text{ mA}$; see Figure 28
On-Resistance Match Between Channels, ΔR_{ON}	170	215	245	Ω max	$V_{DD} = 32.4 \text{ V}$, $V_{SS} = 0 \text{ V}$
	3.5			Ω typ	$V_S = 0 \text{ V}$ to 30 V, $I_S = -1 \text{ mA}$
On-Resistance Flatness, $R_{FLAT(ON)}$	8	9	10	Ω max	
	35			Ω typ	$V_S = 0 \text{ V}$ to 30 V, $I_S = -1 \text{ mA}$
	55	65	70	Ω max	
LEAKAGE CURRENTS					
Source Off Leakage, I_S (Off)	± 0.005			nA typ	$V_{DD} = 39.6 \text{ V}$, $V_{SS} = 0 \text{ V}$
	± 0.1	± 0.2	± 0.4	nA max	$V_S = 1 \text{ V}/30 \text{ V}$, $V_D = 30 \text{ V}/1 \text{ V}$; see Figure 30
Drain Off Leakage, I_D (Off)	± 0.005			nA typ	
	± 0.1	± 0.4	± 1.4	nA max	$V_S = 1 \text{ V}/30 \text{ V}$, $V_D = 30 \text{ V}/1 \text{ V}$; see Figure 30
Channel On Leakage, I_D (On), I_S (On)	± 0.01	± 0.4	± 1.4	nA typ	$V_S = V_D = 1 \text{ V}/30 \text{ V}$; see Figure 27
	± 0.2	± 0.5	± 1.4	nA max	
DIGITAL INPUTS					
Input High Voltage, V_{INH}			2.0	V min	
Input Low Voltage, V_{INL}			0.8	V max	
Input Current, I_{INL} or I_{INH}	0.002			μA typ	$V_{IN} = V_{GND}$ or V_{DD}
			± 0.1	μA max	
Digital Input Capacitance, C_{IN}	3			pF typ	

Parameter	25°C	-40°C to +85°C	-40°C to +125°C	Unit	Test Conditions/Comments
DYNAMIC CHARACTERISTICS¹					
Transition Time, $t_{\text{TRANSITION}}$	170 205			ns typ ns max	$R_L = 300 \Omega$, $C_L = 35 \text{ pF}$ $V_S = 18 \text{ V}$; see Figure 33
t_{ON} (EN)	150 180	225	235	ns typ ns max	$R_L = 300 \Omega$, $C_L = 35 \text{ pF}$ $V_S = 18 \text{ V}$; see Figure 35
t_{OFF} (EN)	180 225	195	215	ns typ ns max	$R_L = 300 \Omega$, $C_L = 35 \text{ pF}$ $V_S = 18 \text{ V}$; see Figure 35
Break-Before-Make Time Delay, t_D	55	225	230	ns typ ns min	$R_L = 300 \Omega$, $C_L = 35 \text{ pF}$ $V_{S1} = V_{S2} = 18 \text{ V}$; see Figure 34
Charge Injection, Q_{INU}	0.3		25	pC typ	$V_S = 18 \text{ V}$, $R_S = 0 \Omega$, $C_L = 1 \text{ nF}$; see Figure 36
Off Isolation	-86			dB typ	$R_L = 50 \Omega$, $C_L = 5 \text{ pF}$, $f = 1 \text{ MHz}$; see Figure 31
Channel-to-Channel Crosstalk	-80			dB typ	$R_L = 50 \Omega$, $C_L = 5 \text{ pF}$, $f = 1 \text{ MHz}$; see Figure 29
-3 dB Bandwidth					$R_L = 50 \Omega$, $C_L = 5 \text{ pF}$; see Figure 32
ADG5208	105			MHz typ	
ADG5209	195			MHz typ	
Insertion Loss	-6.2			dB typ	$R_L = 50 \Omega$, $C_L = 5 \text{ pF}$, $f = 1 \text{ MHz}$; see Figure 32
C_S (Off)	2.7			pF typ	$V_S = 18 \text{ V}$, $f = 1 \text{ MHz}$
C_D (Off)					
ADG5208	32			pF typ	$V_S = 18 \text{ V}$, $f = 1 \text{ MHz}$
ADG5209	16			pF typ	$V_S = 18 \text{ V}$, $f = 1 \text{ MHz}$
C_D (On), C_S (On)					
ADG5208	35			pF typ	$V_S = 18 \text{ V}$, $f = 1 \text{ MHz}$
ADG5209	20			pF typ	$V_S = 18 \text{ V}$, $f = 1 \text{ MHz}$
POWER REQUIREMENTS					
I_{DD}	80 100			μA typ μA max	$V_{\text{DD}} = 39.6 \text{ V}$ Digital inputs = 0 V or V_{DD}
V_{DD}			130 9/40	V min/V max	GND = 0 V, $V_{\text{SS}} = 0 \text{ V}$

¹ Guaranteed by design; not subject to production test.

CONTINUOUS CURRENT PER CHANNEL, S_x, D, OR D_x

Table 5. ADG5208

Parameter	25°C	85°C	125°C	Unit
CONTINUOUS CURRENT, S _x OR D				
V _{DD} = +15 V, V _{SS} = -15 V				
TSSOP (θ _{JA} = 112.6°C/W)	40	24	14.5	mA maximum
LFCSP (θ _{JA} = 30.4°C/W)	69	37	18	mA maximum
V _{DD} = +20 V, V _{SS} = -20 V				
TSSOP (θ _{JA} = 112.6°C/W)	42	26.5	14.5	mA maximum
LFCSP (θ _{JA} = 30.4°C/W)	75	40	18	mA maximum
V _{DD} = 12 V, V _{SS} = 0 V				
TSSOP (θ _{JA} = 112.6°C/W)	28	19	12	mA maximum
LFCSP (θ _{JA} = 30.4°C/W)	40	25	14.5	mA maximum
V _{DD} = 36 V, V _{SS} = 0 V				
TSSOP (θ _{JA} = 112.6°C/W)	40	26	14.5	mA maximum
LFCSP (θ _{JA} = 30.4°C/W)	72	39	18	mA maximum

Table 6. ADG5209

Parameter	25°C	85°C	125°C	Unit
CONTINUOUS CURRENT, S _x OR D _x				
V _{DD} = +15 V, V _{SS} = -15 V				
TSSOP (θ _{JA} = 112.6°C/W)	29	19	12	mA maximum
LFCSP (θ _{JA} = 30.4°C/W)	51	30	16	mA maximum
V _{DD} = +20 V, V _{SS} = -20 V				
TSSOP (θ _{JA} = 112.6°C/W)	30	20	12.5	mA maximum
LFCSP (θ _{JA} = 30.4°C/W)	55	32	17	mA maximum
V _{DD} = 12 V, V _{SS} = 0 V				
TSSOP (θ _{JA} = 112.6°C/W)	20	14	10	mA maximum
LFCSP (θ _{JA} = 30.4°C/W)	29	20	12.5	mA maximum
V _{DD} = 36 V, V _{SS} = 0 V				
TSSOP (θ _{JA} = 112.6°C/W)	30	20	12.5	mA maximum
LFCSP (θ _{JA} = 30.4°C/W)	54	31	17	mA maximum

ABSOLUTE MAXIMUM RATINGS

$T_A = 25^\circ\text{C}$, unless otherwise noted.

Table 7.

Parameter	Rating
V_{DD} to V_{SS}	48 V
V_{DD} to GND	-0.3 V to +48 V
V_{SS} to GND	+0.3 V to -48 V
Analog Inputs ¹	$V_{SS} - 0.3\text{ V}$ to $V_{DD} + 0.3\text{ V}$ or 30 mA, whichever occurs first
Digital Inputs ¹	$V_{SS} - 0.3\text{ V}$ to $V_{DD} + 0.3\text{ V}$ or 30 mA, whichever occurs first
Peak Current, Sx, D, or Dx Pins ADG5208	126 mA (pulsed at 1 ms, 10% duty cycle maximum)
ADG5209	92 mA (pulsed at 1 ms, 10% duty cycle maximum)
Continuous Current, Sx, D, or Dx Pins ²	Data + 15%
Temperature Range	
Operating	-40°C to +125°C
Storage	-65°C to +150°C
Junction Temperature	150°C
Thermal Impedance, θ_{JA}	
16-Lead TSSOP (4-Layer Board)	112.6°C/W
16-Lead LFCSP (4-Layer Board)	30.4°C/W
Reflow Soldering Peak Temperature, Pb Free	260(+0/-5)°C
HBM ESD	
I/O Port to Supplies	8 kV
I/O Port to I/O Port	2 kV
All Other Pins	8 kV

¹ Overvoltages at the Ax, EN, Sx, D, and Dx pins are clamped by internal diodes. Limit current to the maximum ratings given.

² See Table 5 and Table 6.

Stresses at or above those listed under Absolute Maximum Ratings may cause permanent damage to the product. This is a stress rating only; functional operation of the product at these or any other conditions above those indicated in the operational section of this specification is not implied. Operation beyond the maximum operating conditions for extended periods may affect product reliability.

Only one absolute maximum rating can be applied at any one time.

ESD CAUTION



ESD (electrostatic discharge) sensitive device. Charged devices and circuit boards can discharge without detection. Although this product features patented or proprietary protection circuitry, damage may occur on devices subjected to high energy ESD. Therefore, proper ESD precautions should be taken to avoid performance degradation or loss of functionality.

PIN CONFIGURATIONS AND FUNCTION DESCRIPTIONS

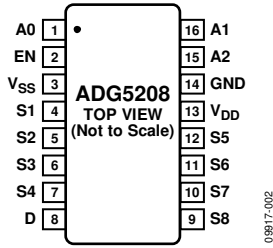
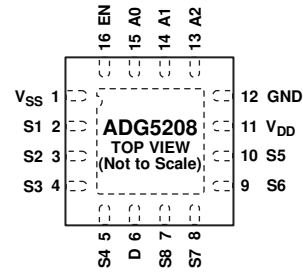

Figure 2. ADG5208 Pin Configuration (TSSOP)



NOTES
 1. THE EXPOSED PAD IS CONNECTED INTERNALLY. FOR INCREASED RELIABILITY OF THE SOLDER JOINTS AND MAXIMUM THERMAL CAPABILITY, IT IS RECOMMENDED THAT THE PAD BE SOLDERED TO THE SUBSTRATE, V_{SS}.

Figure 3. ADG5208 Pin Configuration (LFCSP)

Table 8. ADG5208 Pin Function Descriptions

Pin No.		Mnemonic	Description
TSSOP	LFCSP		
1	15	A0	Logic Control Input.
2	16	EN	Active High Digital Input. When low, the device is disabled and all switches are off. When high, the Ax logic inputs determine the on switches.
3	1	V _{SS}	Most Negative Power Supply Potential. In single-supply applications, this pin can be connected to ground.
4	2	S1	Source Terminal 1. This pin can be an input or an output.
5	3	S2	Source Terminal 2. This pin can be an input or an output.
6	4	S3	Source Terminal 3. This pin can be an input or an output.
7	5	S4	Source Terminal 4. This pin can be an input or an output.
8	6	D	Drain Terminal. This pin can be an input or an output.
9	7	S8	Source Terminal 8. This pin can be an input or an output.
10	8	S7	Source Terminal 7. This pin can be an input or an output.
11	9	S6	Source Terminal 6. This pin can be an input or an output.
12	10	S5	Source Terminal 5. This pin can be an input or an output.
13	11	V _{DD}	Most Positive Power Supply Potential.
14	12	GND	Ground (0 V) Reference.
15	13	A2	Logic Control Input.
16	14	A1	Logic Control Input.
	EP	Exposed Pad	The exposed pad is connected internally. For increased reliability of the solder joints and maximum thermal capability, it is recommended that the pad be soldered to the substrate, V _{SS} .

Table 9. ADG5208 Truth Table

A2	A1	A0	EN	On Switch
X ¹	X ¹	X ¹	0	None
0	0	0	1	1
0	0	1	1	2
0	1	0	1	3
0	1	1	1	4
1	0	0	1	5
1	0	1	1	6
1	1	0	1	7
1	1	1	1	8

¹ X is don't care.

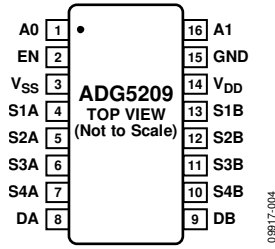
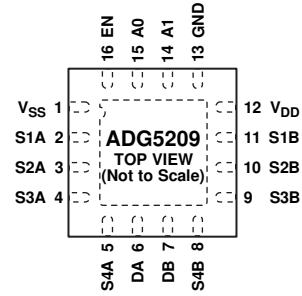

Figure 4. ADG5209 Pin Configuration (TSSOP)



NOTES
 1. THE EXPOSED PAD IS CONNECTED INTERNALLY. FOR INCREASED RELIABILITY OF THE SOLDER JOINTS AND MAXIMUM THERMAL CAPABILITY, IT IS RECOMMENDED THAT THE PAD BE SOLDERED TO THE SUBSTRATE, V_{SS}.

Figure 5. ADG5209 Pin Configuration (LFCSP)

Table 10. ADG5209 Pin Function Descriptions

Pin No.		Mnemonic	Description
TSSOP	LFCSP		
1	15	A0	Logic Control Input.
2	16	EN	Active High Digital Input. When low, the device is disabled and all switches are off. When high, Ax logic inputs determine the on switches.
3	1	V _{SS}	Most Negative Power Supply Potential. In single-supply applications, this pin can be connected to ground.
4	2	S1A	Source Terminal 1A. This pin can be an input or an output.
5	3	S2A	Source Terminal 2A. This pin can be an input or an output.
6	4	S3A	Source Terminal 3A. This pin can be an input or an output.
7	5	S4A	Source Terminal 4A. This pin can be an input or an output.
8	6	DA	Drain Terminal A. This pin can be an input or an output.
9	7	DB	Drain Terminal B. This pin can be an input or an output.
10	8	S4B	Source Terminal 4B. This pin can be an input or an output.
11	9	S3B	Source Terminal 3B. This pin can be an input or an output.
12	10	S2B	Source Terminal 2B. This pin can be an input or an output.
13	11	S1B	Source Terminal 1B. This pin can be an input or an output.
14	12	V _{DD}	Most Positive Power Supply Potential.
15	13	GND	Ground (0 V) Reference.
16	14	A1	Logic Control Input.
	EP	Exposed Pad	The exposed pad is connected internally. For increased reliability of the solder joints and maximum thermal capability, it is recommended that the pad be soldered to the substrate, V _{SS} .

Table 11. ADG5209 Truth Table

A1	A0	EN	On Switch Pair
X ¹	X ¹	0	None
0	0	1	1
0	1	1	2
1	0	1	3
1	1	1	4

¹ X is don't care.

TYPICAL PERFORMANCE CHARACTERISTICS

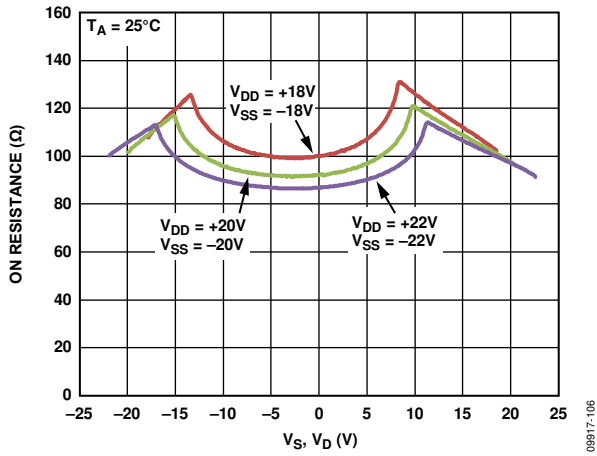

Figure 6. R_{ON} as a Function of V_S, V_D (± 20 V Dual Supply)

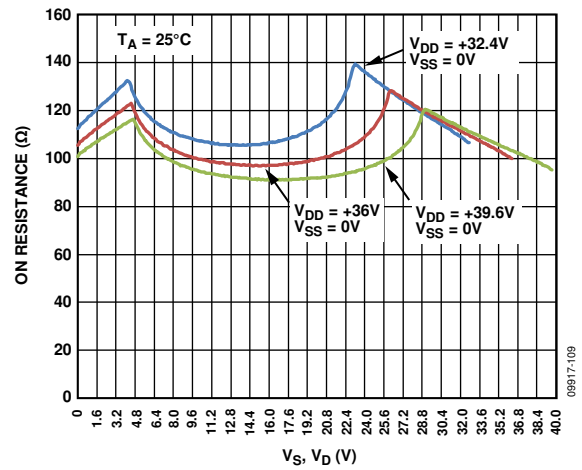

Figure 9. R_{ON} as a Function of V_S, V_D (36 V Single Supply)

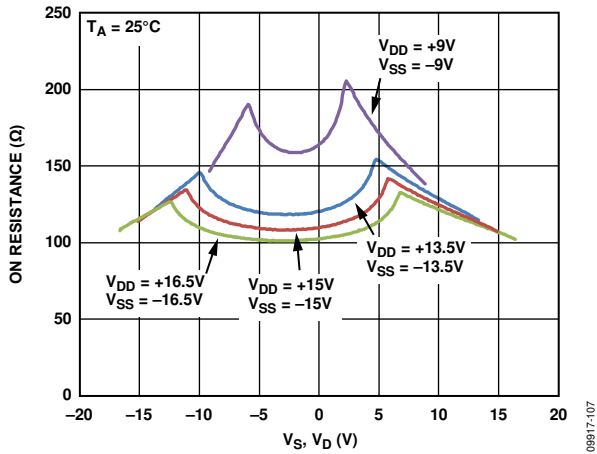

Figure 7. R_{ON} as a Function of V_S, V_D (± 15 V Dual Supply)

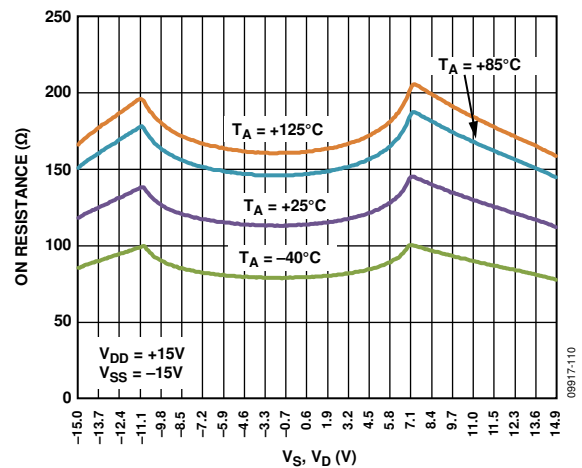

Figure 10. R_{ON} as a Function of V_S, V_D for Different Temperatures, ± 15 V Dual Supply

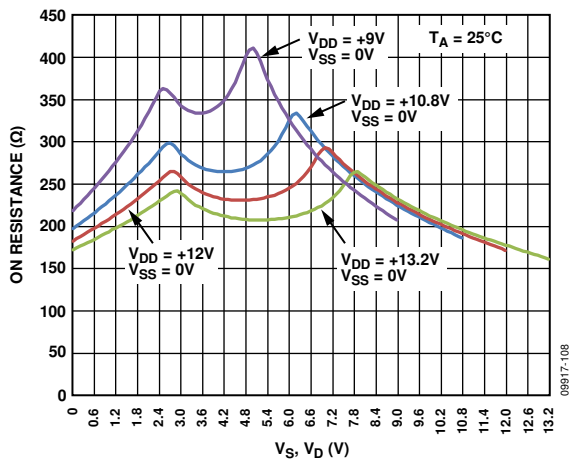

Figure 8. R_{ON} as a Function of V_S, V_D (12 V Single Supply)

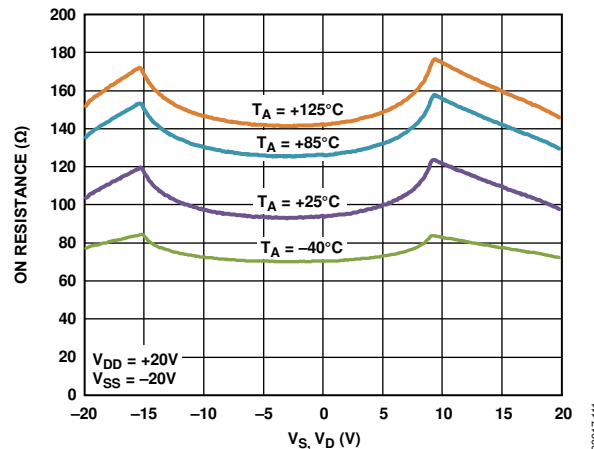

Figure 11. R_{ON} as a Function of V_S, V_D for Different Temperatures, ± 20 V Dual Supply

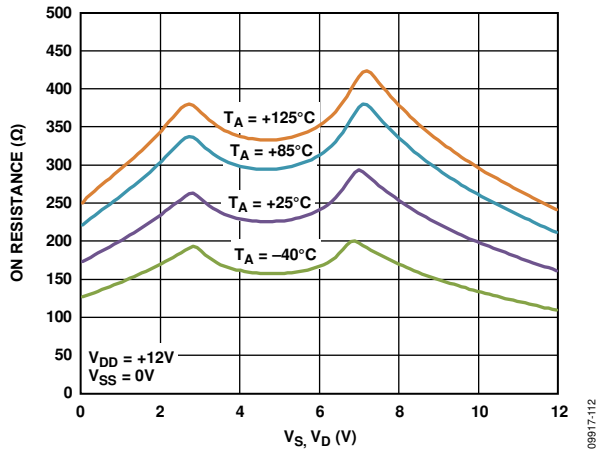

Figure 12. R_{ON} as a Function of V_S, V_D for Different Temperatures, 12 V Single Supply

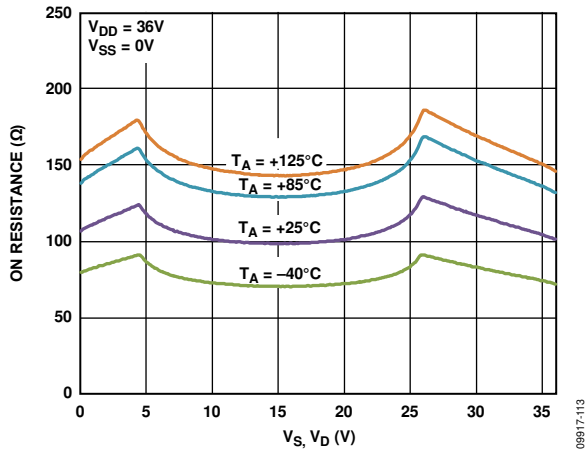

Figure 13. R_{ON} as a Function of V_S, V_D for Different Temperatures, 36 V Single Supply

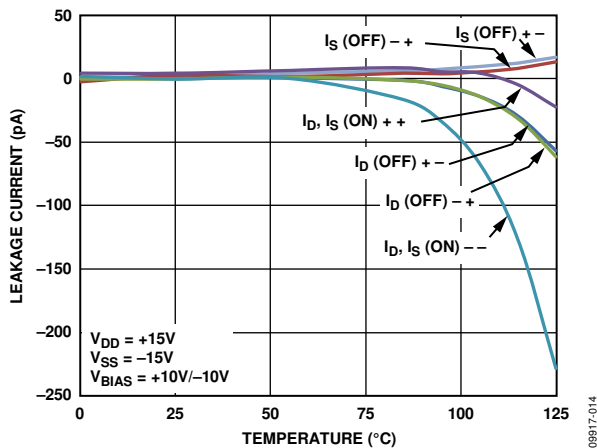

Figure 14. Leakage Currents vs. Temperature, $\pm 15\text{V}$ Dual Supply

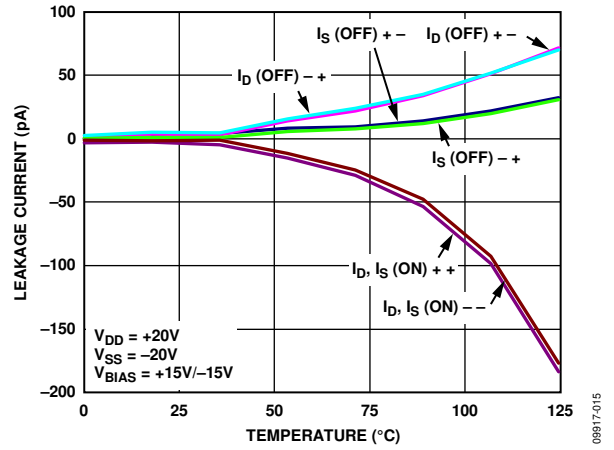

Figure 15. Leakage Currents vs. Temperature, $\pm 20\text{V}$ Dual Supply

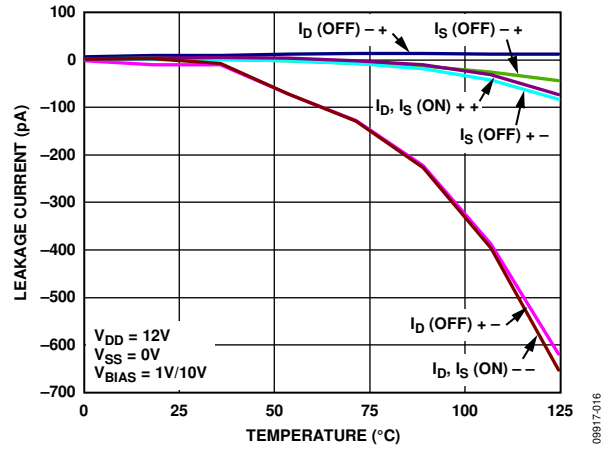

Figure 16. Leakage Currents vs. Temperature, 12 V Single Supply

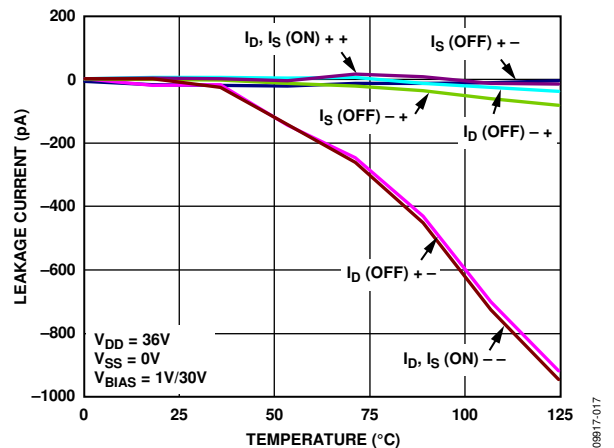

Figure 17. Leakage Currents vs. Temperature, 36 V Single Supply

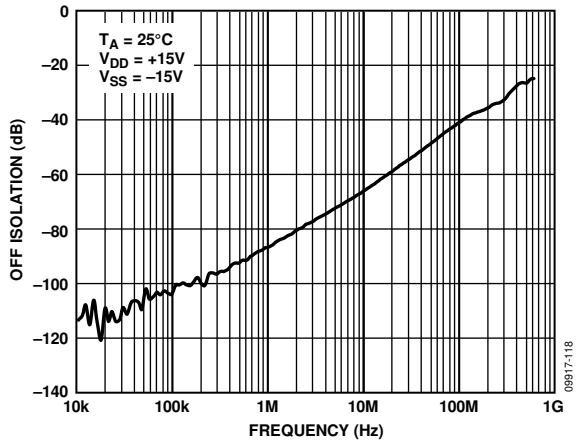

Figure 18. Off Isolation vs. Frequency, ±15 V Dual Supply

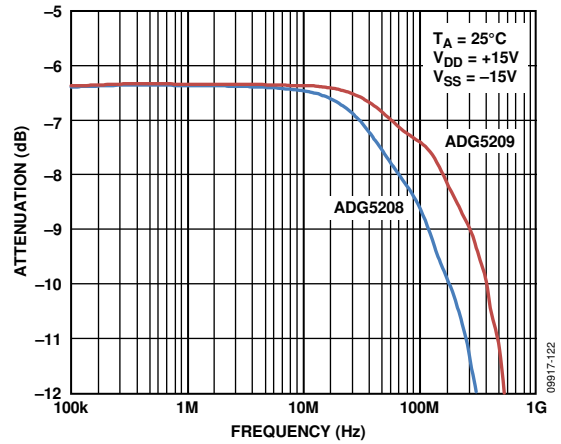

Figure 21. Bandwidth

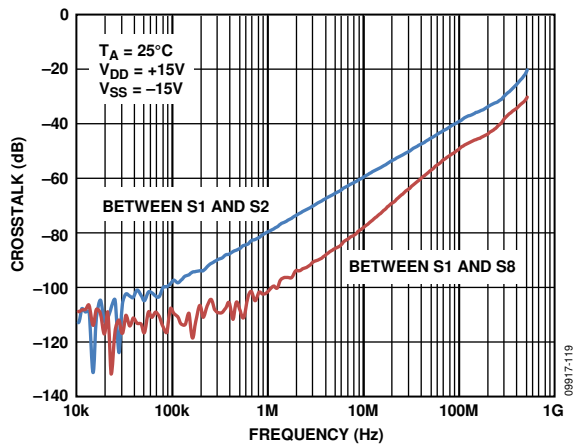

Figure 19. Crosstalk vs. Frequency, ±15 V Dual Supply

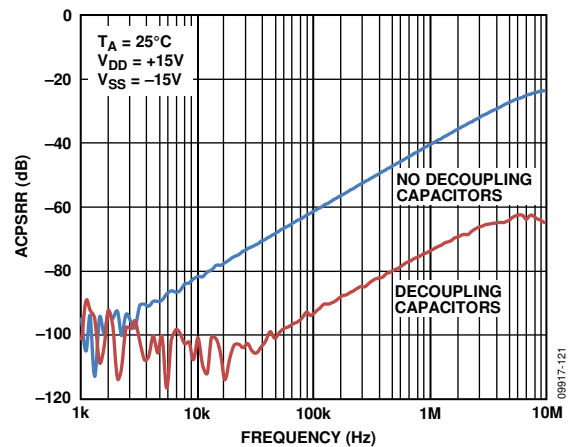

Figure 22. ACPSRR vs. Frequency, ±15 V Dual Supply

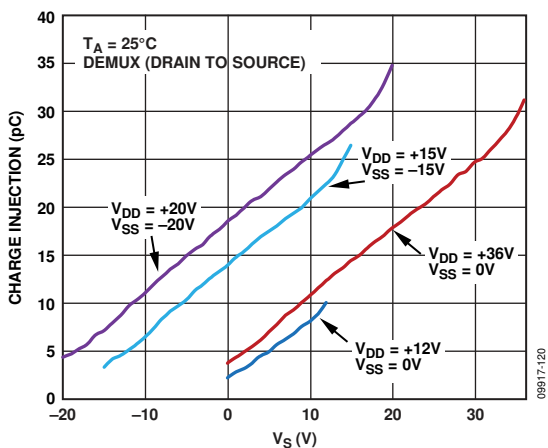

Figure 20. Charge Injection vs. Source Voltage, Drain to Source

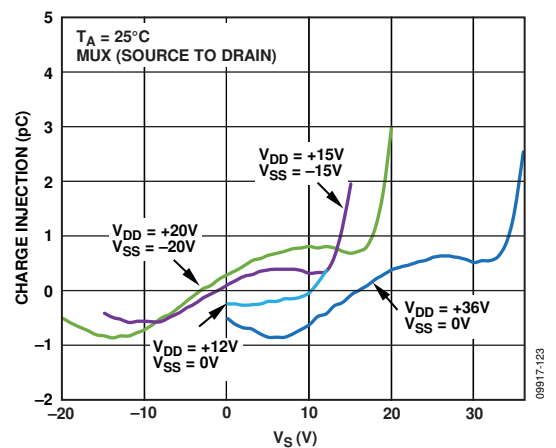

Figure 23. Charge Injection vs. Source Voltage, Source to Drain

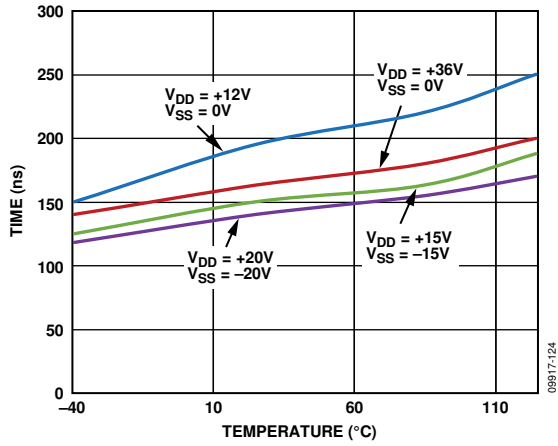

Figure 24. $t_{TRANSITION}$ Times vs. Temperature

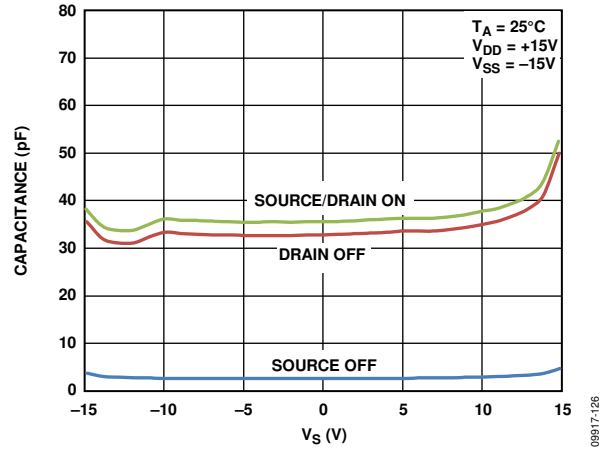

Figure 26. ADG5208 Capacitance vs. Source Voltage, ± 15 V Dual Supply

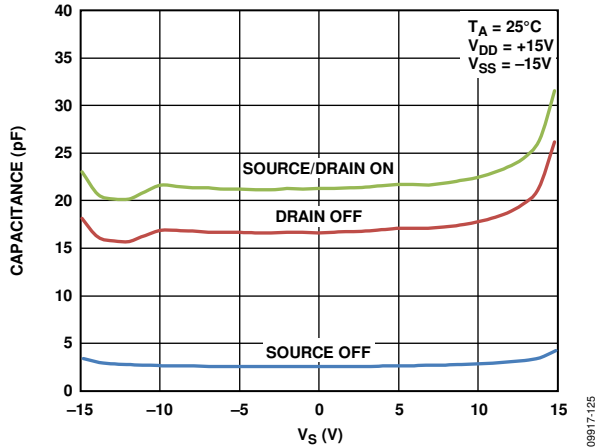

Figure 25. ADG5209 Capacitance vs. Source Voltage, ± 15 V Dual Supply

TEST CIRCUITS

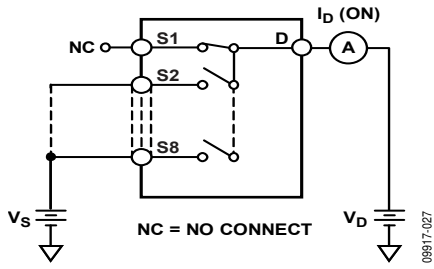

Figure 27. On Leakage

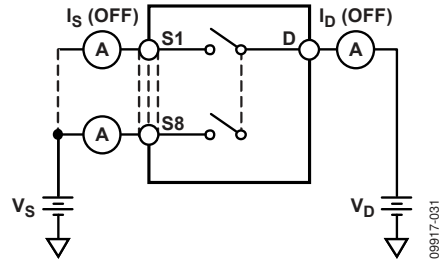

Figure 30. Off Leakage

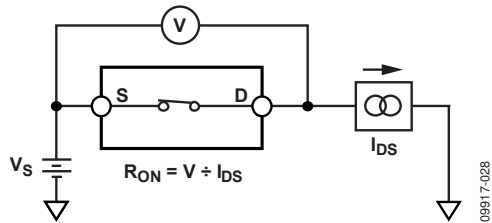

Figure 28. On Resistance

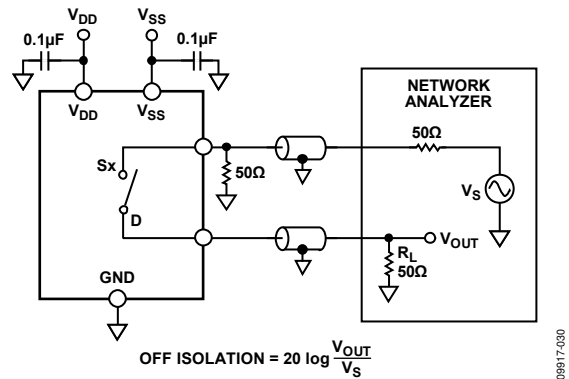

Figure 31. Off Isolation

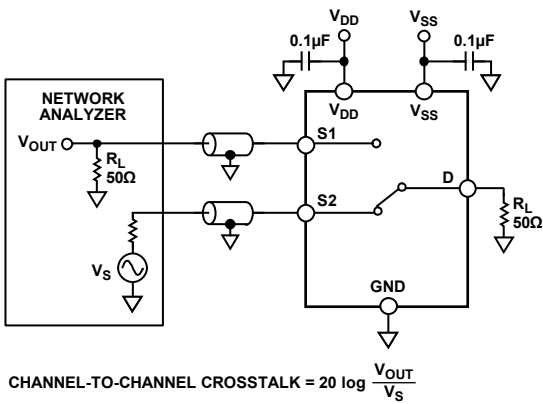

Figure 29. Channel-to-Channel Crosstalk

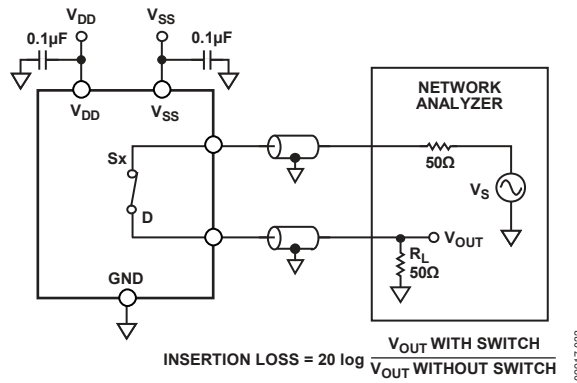

Figure 32. Bandwidth

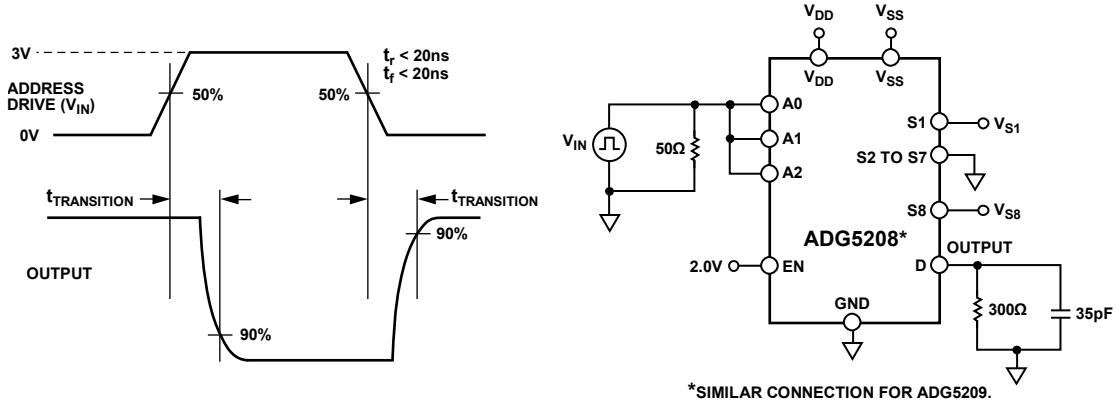

Figure 33. Address to Output Switching Times, $t_{\text{TRANSITION}}$

09917-034

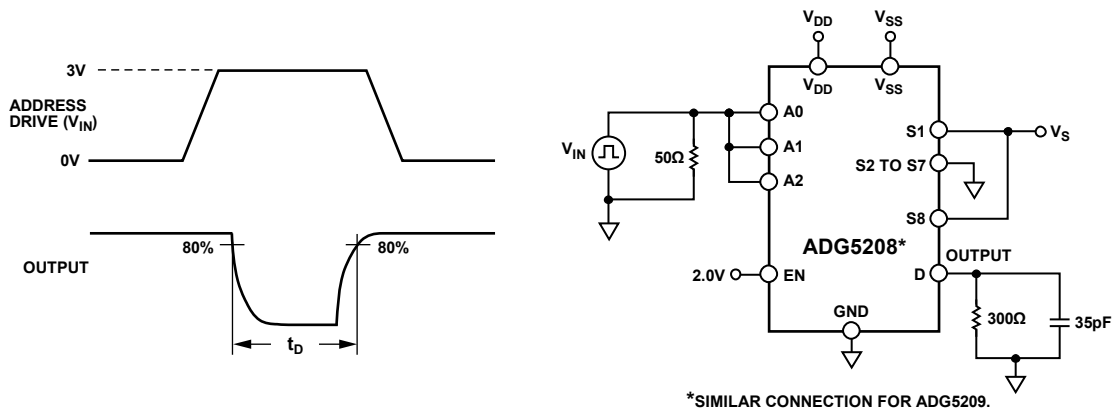

Figure 34. Break-Before-Make Time Delay, t_D

09917-035

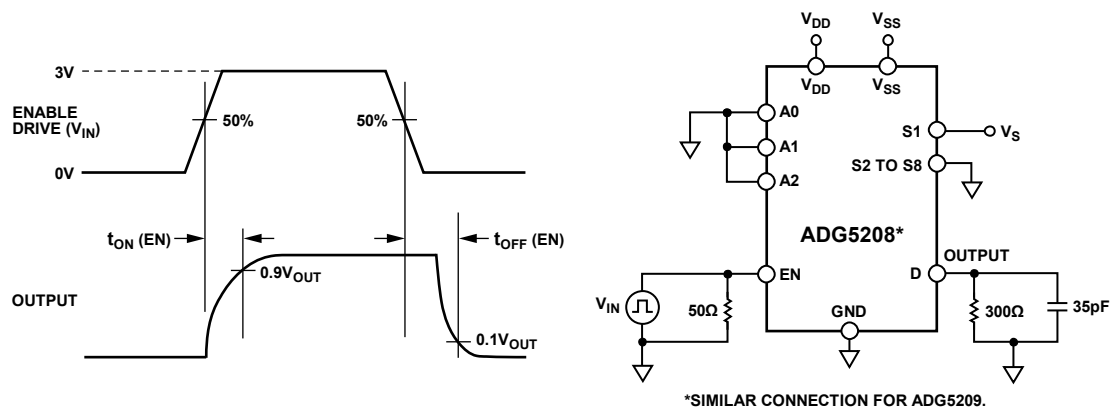

Figure 35. Enable Delay, $t_{\text{ON}}(\text{EN})$, $t_{\text{OFF}}(\text{EN})$

09917-036

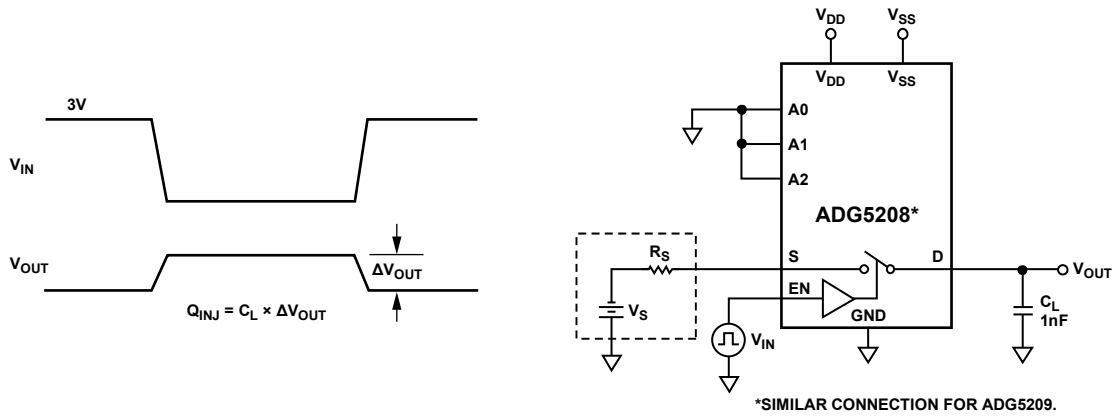

Figure 36. Charge Injection

09917_037

TERMINOLOGY

I_{DD}

I_{DD} represents the positive supply current.

I_{SS}

I_{SS} represents the negative supply current.

V_D, V_S

V_D and V_S represent the analog voltage on Terminal D and Terminal S, respectively.

R_{ON}

R_{ON} is the ohmic resistance between Terminal D and Terminal S.

ΔR_{ON}

ΔR_{ON} represents the difference between the R_{ON} of any two channels.

$R_{FLAT(ON)}$

Flatness that is defined as the difference between the maximum and minimum value of on resistance measured over the specified analog signal range is represented by $R_{FLAT(ON)}$.

I_S (Off)

I_S (Off) is the source leakage current with the switch off.

I_D (Off)

I_D (Off) is the drain leakage current with the switch off.

I_D (On), I_S (On)

I_D (On) and I_S (On) represent the channel leakage currents with the switch on.

V_{INL}

V_{INL} is the maximum input voltage for Logic 0.

V_{INH}

V_{INH} is the minimum input voltage for Logic 1.

I_{INL}, I_{INH}

I_{INL} and I_{INH} represent the low and high input currents of the digital inputs.

C_D (Off)

C_D (Off) represents the off switch drain capacitance, which is measured with reference to ground.

C_S (Off)

C_S (Off) represents the off switch source capacitance, which is measured with reference to ground.

C_D (On), C_S (On)

C_D (On) and C_S (On) represent on switch capacitances, which are measured with reference to ground.

C_{IN}

C_{IN} represents digital input capacitance.

t_{ON} (EN)

t_{ON} (EN) represents the delay time between the 50% and 90% points of the digital input and switch on condition.

t_{OFF} (EN)

t_{OFF} (EN) represents the delay time between the 50% and 90% points of the digital input and switch off condition.

$t_{TRANSITION}$

$t_{TRANSITION}$ represents the delay time between the 50% and 90% points of the digital inputs and the switch on condition when switching from one address state to another.

Break-Before-Make Time Delay (t_D)

t_D represents the off time measured between the 80% point of both switches when switching from one address state to another.

Off Isolation

Off isolation is a measure of unwanted signal coupling through an off channel.

Charge Injection

Charge injection is a measure of the glitch impulse transferred from the digital input to the analog output during switching.

Crosstalk

Crosstalk is a measure of unwanted signal that is coupled through from one channel to another as a result of parasitic capacitance.

Bandwidth

Bandwidth is the frequency at which the output is attenuated by 3 dB.

On Response

On response is the frequency response of the on switch.

AC Power Supply Rejection Ratio (ACPSRR)

ACPSRR is a measure of the ability of a device to avoid coupling noise and spurious signals that appear on the supply voltage pin to the output of the switch. The dc voltage on the device is modulated by a sine wave of 0.62 V p-p. The ratio of the amplitude of signal on the output to the amplitude of the modulation is the ACPSRR.

TRENCH ISOLATION

In the [ADG5208/ADG5209](#), an insulating oxide layer (trench) is placed between the NMOS and the PMOS transistors of each CMOS switch. Parasitic junctions, which occur between the transistors in junction isolated switches, are eliminated, and the result is a completely latch-up proof switch.

In junction isolation, the N and P wells of the PMOS and NMOS transistors form a diode that is reverse-biased under normal operation. However, during overvoltage conditions, this diode can become forward-biased. A silicon controlled rectifier (SCR) type circuit is formed by the two transistors, causing a significant amplification of the current that, in turn, leads to latch-up. With trench isolation, this diode is removed, and the result is a latch-up proof switch.

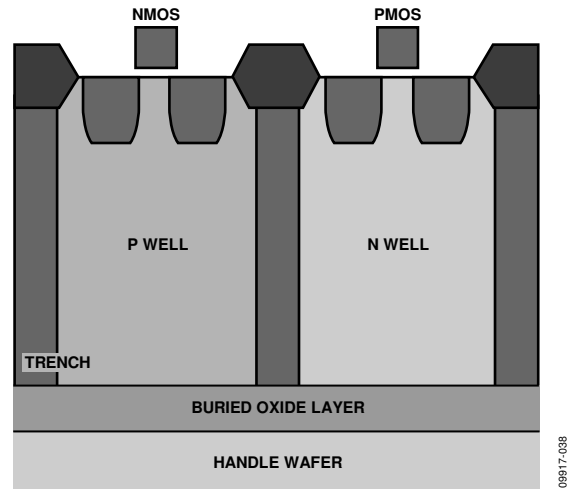
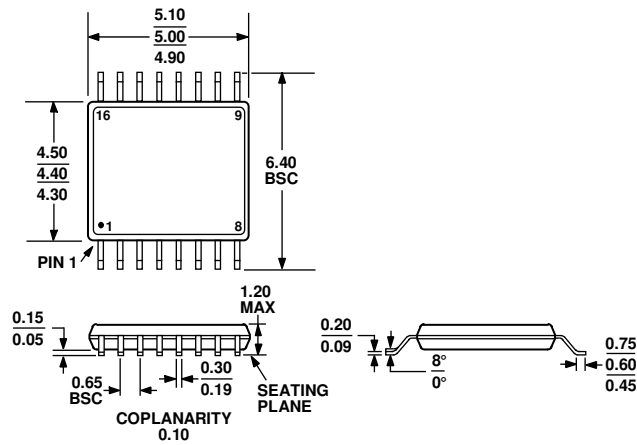

Figure 37. Trench Isolation

APPLICATIONS INFORMATION

The low capacitance latch-up immune family of switches and multiplexers provides a robust solution for instrumentation, industrial, automotive, aerospace, and other harsh environments that are prone to latch-up, which is an undesirable high current state that can lead to device failure and persist until the power supply is turned off. The [ADG5208/ADG5209](#) high voltage switches allow single-supply operation from 9 V to 40 V and dual-supply operation from ± 9 V to ± 22 V.

OUTLINE DIMENSIONS



COMPLIANT TO JEDEC STANDARDS MO-153-AB

Figure 38. 16-Lead Thin Shrink Small Outline Package [TSSOP] (RU-16)
Dimensions shown in millimeters

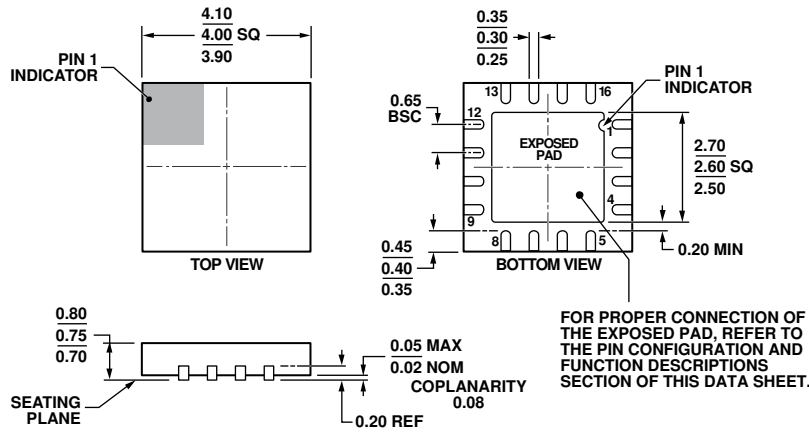

FOR PROPER CONNECTION OF THE EXPOSED PAD, REFER TO THE PIN CONFIGURATION AND FUNCTION DESCRIPTIONS SECTION OF THIS DATA SHEET.

COMPLIANT TO JEDEC STANDARDS MO-220-WGGC.

Figure 39. 16-Lead Lead Frame Chip Scale Package [LFCSP_WQ] (CP-16-17)
Dimensions shown in millimeters

08-16-2010-C

ORDERING GUIDE

Model ¹	Temperature Range	Package Description	Package Option
ADG5208BCPZ-RL7	-40°C to +125°C	16-Lead Lead Frame Chip Scale Package [LFCSP_WQ]	CP-16-17
ADG5208BRUZ	-40°C to +125°C	16-Lead Thin Shrink Small Outline Package [TSSOP]	RU-16
ADG5208BRUZ-RL7	-40°C to +125°C	16-Lead Thin Shrink Small Outline Package [TSSOP]	RU-16
ADG5209BCPZ-RL7	-40°C to +125°C	16-Lead Lead Frame Chip Scale Package [LFCSP_WQ]	CP-16-17
ADG5209BRUZ	-40°C to +125°C	16-Lead Thin Shrink Small Outline Package [TSSOP]	RU-16
ADG5209BRUZ-RL7	-40°C to +125°C	16-Lead Thin Shrink Small Outline Package [TSSOP]	RU-16

¹ Z = RoHS Compliant Part.

NOTES

NOTES