

1.5A, 1.5 MHz adjustable, step-down switching regulator in DFN6

Features

- Step-down current mode PWM (1.5MHz) DC-DC converter
- 2% DC output voltage tolerance
- Internal soft start for START-UP current limitation and power on delay of 50-100µs
- Typical efficiency: > 70% over all operating conditions
- 1.5A Output current capability
- Not switching quiescent current: max 2.5mA over temperature range
- Switch V_{DS} : max 350mV @ $I_{SW}=750mA$
- Uses tiny capacitors and inductors
- Available in DFN 3x3 exposed pad

Description

The ST1S03 is a step down DC-DC converter optimized for powering low-voltage digital core in HDD applications and, generally, to replace the high current linear solution when the power dissipation may cause an high heating of the application environment. It provides up to 1.5A

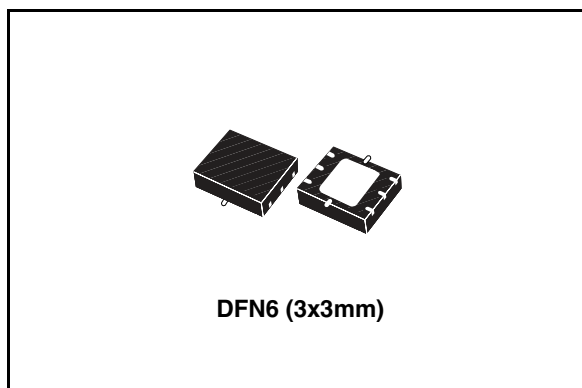

over an input voltage range of 3V to 16V. An high switching frequency (1.5MHz) allows the use of tiny surface-mount components: as well as the resistor divider to set the output voltage value, only an inductor, a schottky diode and two capacitors are required. Besides, a low output ripple is guaranteed by the current mode PWM topology and by the use of low E.S.R. SMD ceramic capacitors. The device is thermal protected and current limited to prevent damages due to accidental short circuit. The ST1S03 is available in DFN6.

Order codes

Part number	Packaging	Package
ST1S03PM	ST1S03PMR	DFN6 (3x3 mm)
ST1S03PU	ST1S03PUR	DFN6D (3x3 mm)

Contents

1	Diagram	3
2	Pin configuration	4
3	Maximum ratings	5
4	Electrical characteristics	6
5	Application notes	7
6	Typical application	8
7	Typical performance characteristics	9
8	Package mechanical data	12
9	Revision history	16

1 Diagram

Figure 1. Schematic diagram

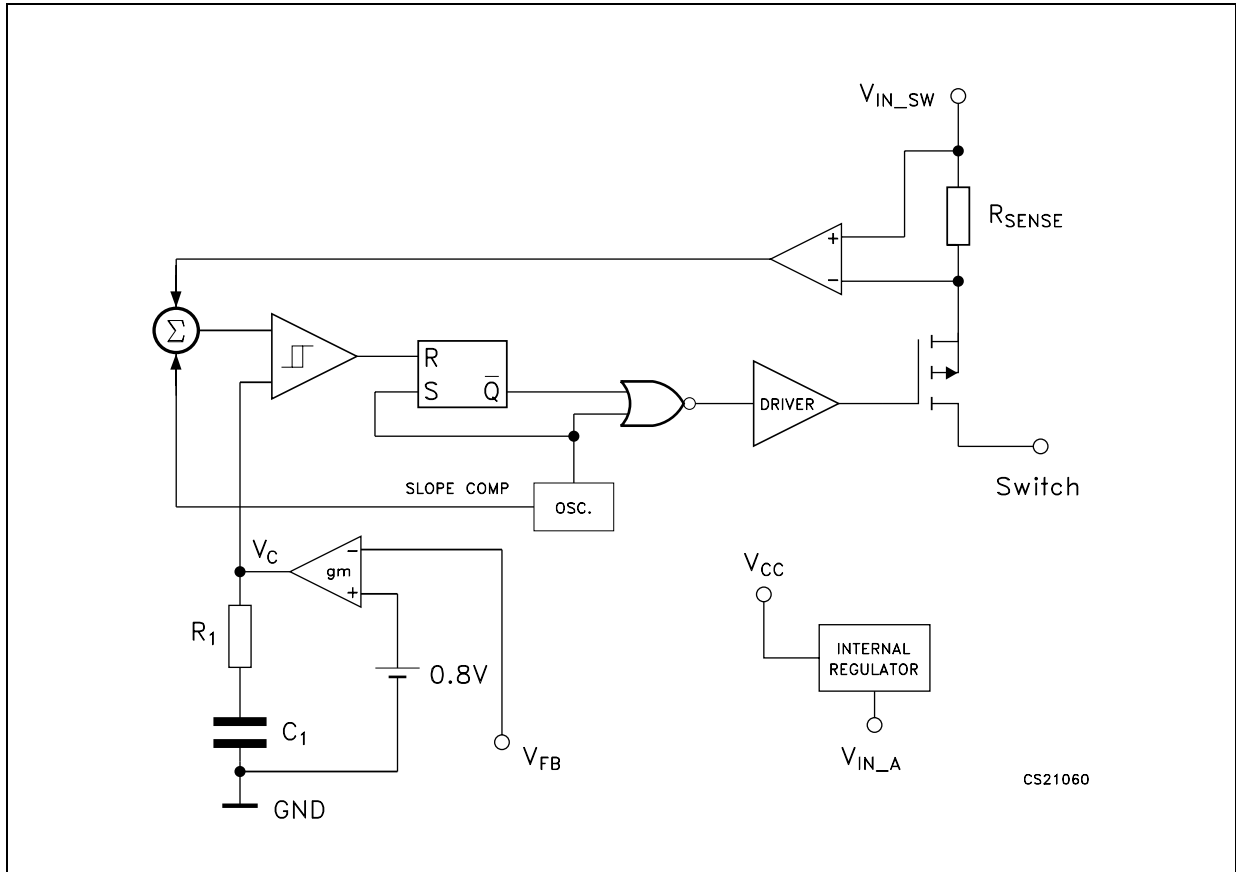

2 Pin configuration

Figure 2. Pin connections (top view)

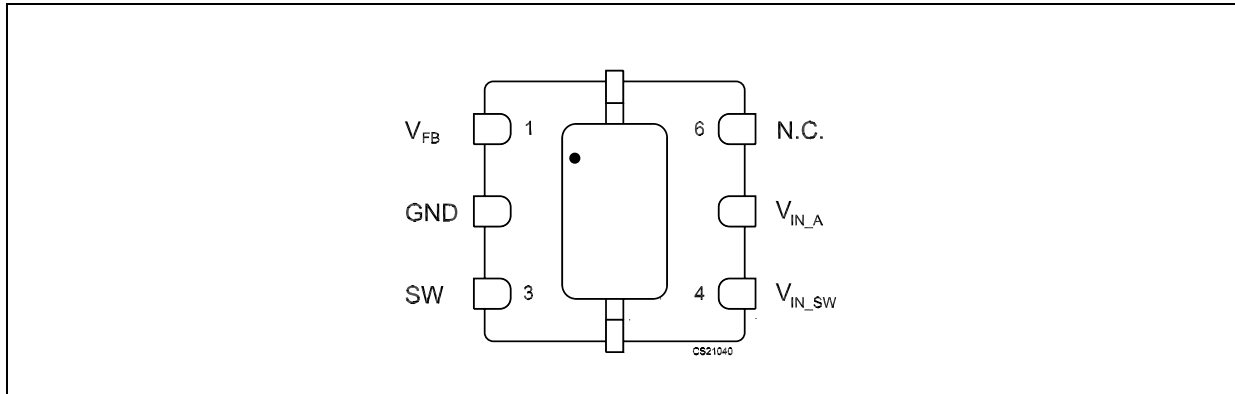

Table 1. Pin description

Pin N°	Symbol	Name and function
1	V_{FB}	Voltage of Feedback
2	GND	System Ground
3	SW	Output of the internal Power Switch
4	V_{IN_SW}	Power Supply for the MOSFET Switch
5	V_{IN_A}	Power Supply for the Analog Circuit
6	N.C.	Not Connected

3 Maximum ratings

Table 2. Absolute maximum ratings

Symbol	Parameter	Value	Unit
V_{I_SW}	Positive Power Supply Voltage	-0.3 to 16	V
V_{I_SW}	Positive Power Supply Voltage	-0.3 to 16	V
SWITCH Voltage	Max Voltage of output pin	-0.3 to 16	V
V_{FB}	Feedback Voltage	2.5	V
I_{VFB}	Common mode input voltage	± 1	mA
T_J	Max Junction Temperature	150	$^{\circ}\text{C}$
T_{STG}	Storage Temperature Range	-25 to 150	$^{\circ}\text{C}$
T_{LEAD}	Lead Temperature (Soldering) 10 Sec.	300	$^{\circ}\text{C}$

Note: Absolute Maximum Ratings are those values beyond which damage to the device may occur. Functional Operation under these conditions is not implied.

Table 3. Thermal data

Symbol	Parameter	Value	Unit
R_{thJC}	Thermal resistance junction-case	10	$^{\circ}\text{C}/\text{W}$
R_{thJA}	Thermal resistance junction-ambient	55	$^{\circ}\text{C}/\text{W}$

4 Electrical characteristics

Table 4. Electrical characteristics ($V_{IN_SW} = V_{IN_A} = 5V$, $C_I = 4.7\mu F$, $C_O = 22\mu F$, $L1 = 3.3\mu H$, $T_J = 0$ to $125^\circ C$, unless otherwise specified. Typical values are referred to $25^\circ C$)

Symbol	Parameter	Test Conditions	Min.	Typ.	Max.	Unit
FB	Feedback voltage		784	800	816	mV
PSRR	Feedback PSRR	1Hz < Frequency V_{IN}		-60		dB
I_{FB}	V_{FB} Pin bias current				600	nA
BW	Bandwidth of error amplifier	Closed Loop		300		KHz
I_Q	Quiescent current	No Switching			2.5	mA
I_O	Output current	$V_{IN} = 3V$ to $16V$	1.5			A
I_{MIN}	Minimum output current		1			mA
$\%V_O/\Delta V_{IN}$	Reference line regulation	$V_{IN} = 3V$ to $16V$		0.032	0.06	$\%V_O/\Delta V_{IN}$
$\%V_O/\Delta I_O$	Reference load regulation	$I_O = 10mA$ to $1.2A$		0.0014	0.003	$\%V_O/mA$
PWM f_S	PWM Switching frequency ⁽¹⁾	$V_{FB} = 0.8V$, $T_A = 25^\circ C$	1.2	1.5	1.8	MHz
D_{MAX}	Maximum duty cycle			87		%
I_{SWL}	Switching current limitation		1.65			A
V_{DS}	Switch V_{DS}	$I_{SW} = 750 mA$		200	350	mV
E	Efficiency	$I_O = 10mA$ to $1.2A$	70			%
T_{SHDN}	Thermal shut down ⁽¹⁾		130	150		$^\circ C$
T_{HYS}	Thermal shut down hysteresis ⁽¹⁾			15		$^\circ C$
$\Delta V_O/\Delta I_O$	Load transient response ⁽¹⁾	$I_O = 100mA$ to $700mA$ $t_R = t_F \geq 100ns$, $T_A = 25^\circ C$	-5		+5	$\%V_O$
$\Delta V_O/\Delta I_O @ I_O=short$	Short circuit removal response ⁽¹⁾	$I_O = 10mA$ to short, $T_A = 25^\circ C$			+5	$\%V_O$

1. Guaranteed by design, but not tested in production.

5 Application notes

The ST1S03 is an adjustable current mode PWM step-down DC/DC converter with internal 1.5A power switch, packaged in 6-lead DFN 3x3.

It's a complete 1.5A switching regulator with its internal compensation eliminating additional component.

The constant frequency, current mode, PWM architecture and stable operation with ceramic capacitors results in low, predictable output ripple. However, in order to keep the output regulated, the device goes in pulse skipping mode when a very light load is required.

To clamp the error amplifier reference voltage a Soft Start control block generating a voltage ramp, has been implemented. Besides an On-Chip Power on Reset of 50 = 100µs ensure the proper operation when switching on the power supply. Other circuits fitted to the device protection are the Thermal Shut down block which turn off the regulator when the junction temperature exceeds 150°C typically and the Cycle-by-cycle Current Limiting that provides protection against shorted outputs.

Being the ST1S03 an adjustable regulator, the output voltage is determined by an external resistor divider. The desired value is given by the following equation:

$$V_O = V_{FB} [1+R1/R2]$$

To make the device working, only other four external components are required: a Schottky diode, an inductor and two capacitors. The chosen inductor must be able to not saturate at the peak current level. Besides, its value can be selected keeping in account that a large inductor value increases the efficiency at low output current and reduces output voltage ripple, while a smaller inductor can be chosen when it is important to reduce the package size and the total cost of the application. Finally, the ST1S03 has been designed to work properly with X5R or X7R SMD ceramic capacitors both at the input and at the output. this kind of capacitors, thanks to their very low series resistance (ESR), minimize the output voltage ripple. Other low ESR capacitors can be used according to the need of the application without invalidating the right functioning of the device. Due to the high switching frequency and peak current, it is important to optimize the application environment reducing the length of the PCB traces and placing all the external component near the device.

6 Typical application

Figure 3. Application circuits

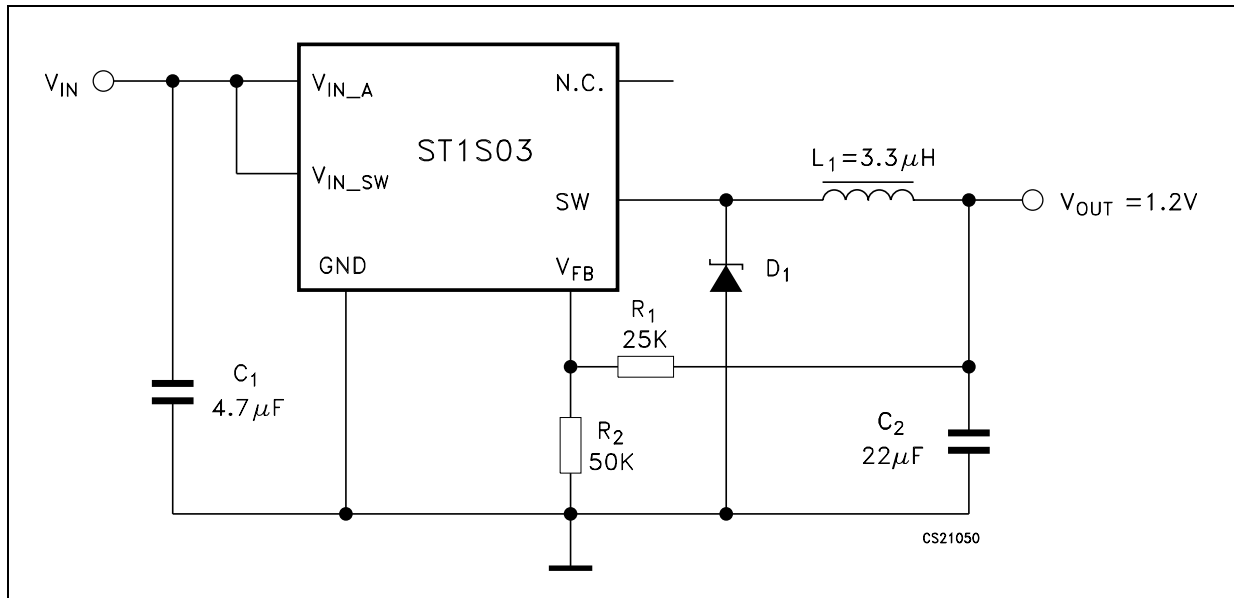

7 Typical performance characteristics

($L_1=3.3\mu\text{H}$, $C_1 = 4.7\mu\text{F}$, $C_O = 22\mu\text{F}$, unless otherwise specified)

Figure 4. Load voltage feedback vs temp.

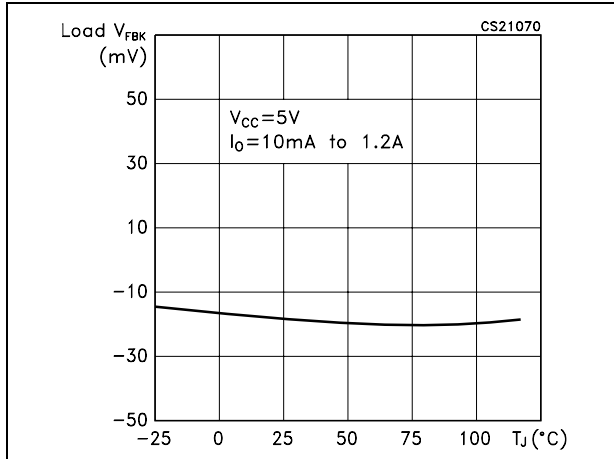

Figure 5. Voltage feedback vs temperature

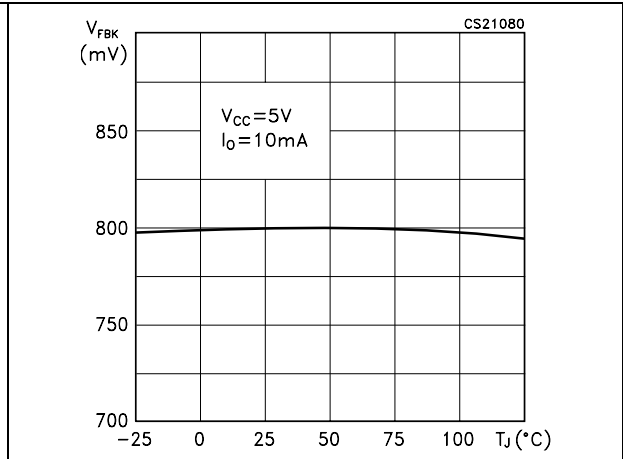

Figure 6. Line output voltage regulation vs temperature

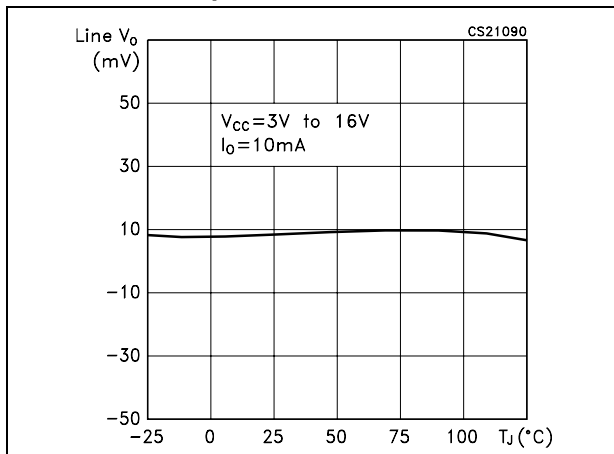

Figure 7. Line voltage feedback vs temperature

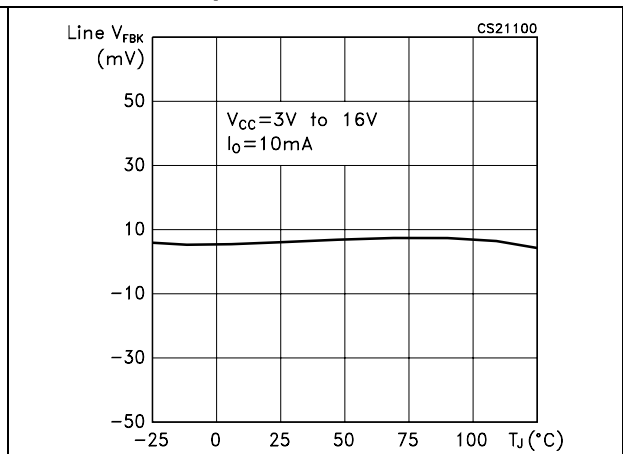

Figure 8. Voltage feedback vs output current

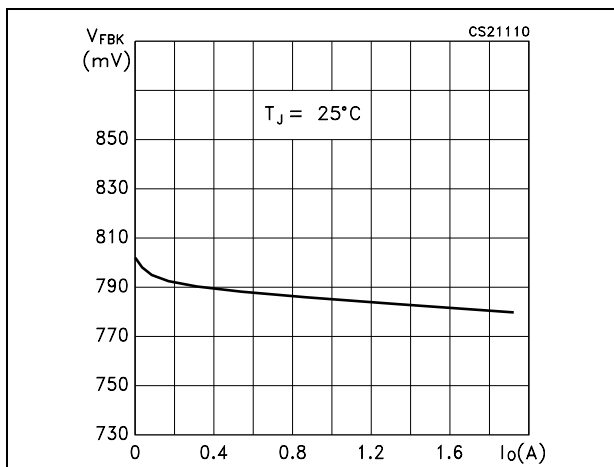

Figure 9. PWM Switching frequency vs temperature

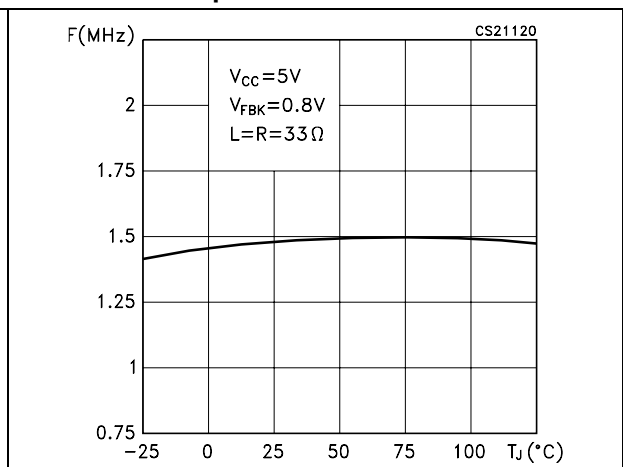

Figure 10. Quiescent current vs temperature

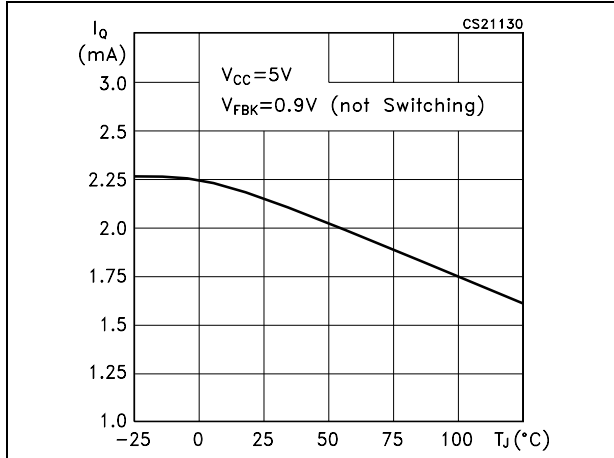

Figure 11. Quiescent current vs input voltage

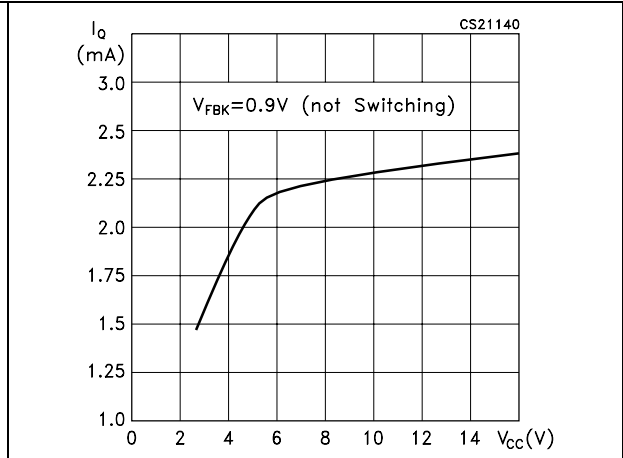

Figure 12. Minimum operating voltage vs output voltage

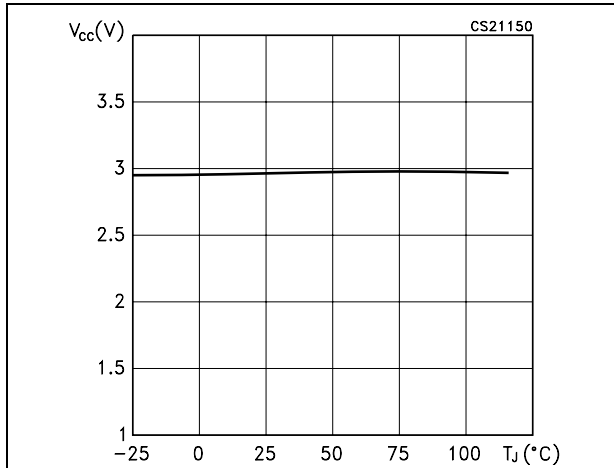

Figure 13. Efficiency vs temperature

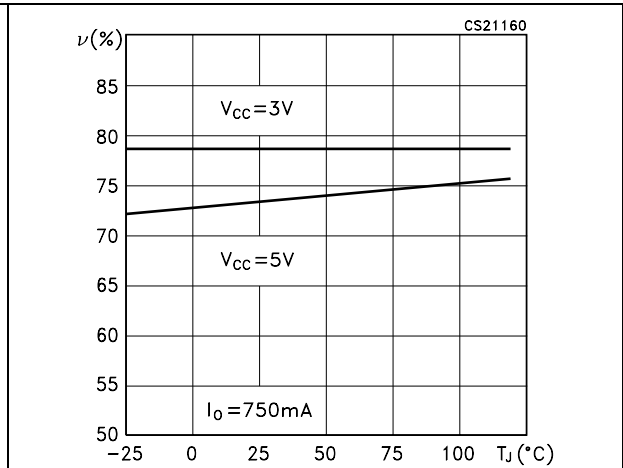

Figure 14. Efficiency vs output current

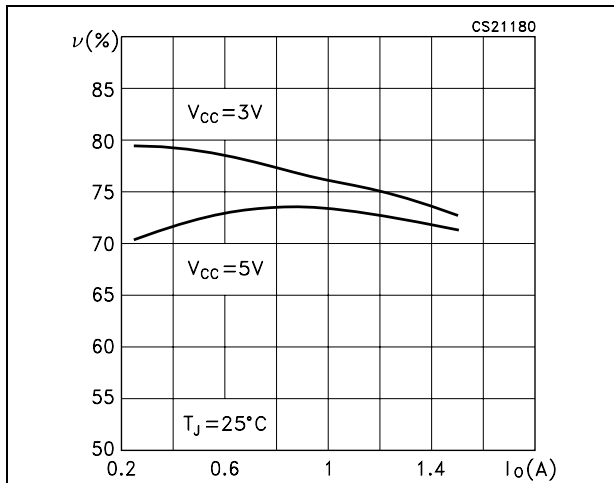

Figure 15. Switch VDS vs temperature

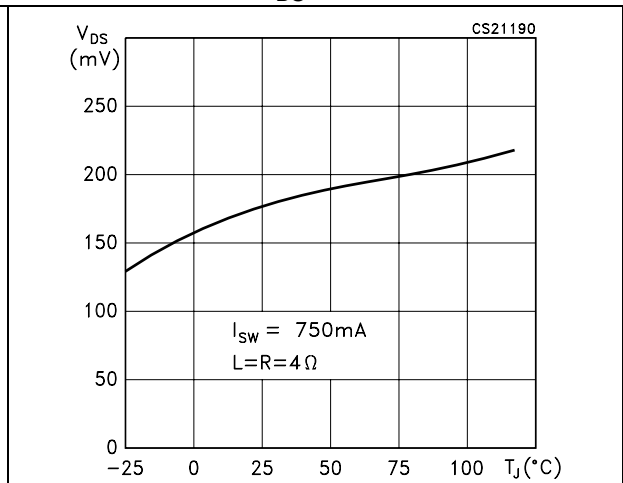

Figure 16. Switch RDS-ON vs temperature

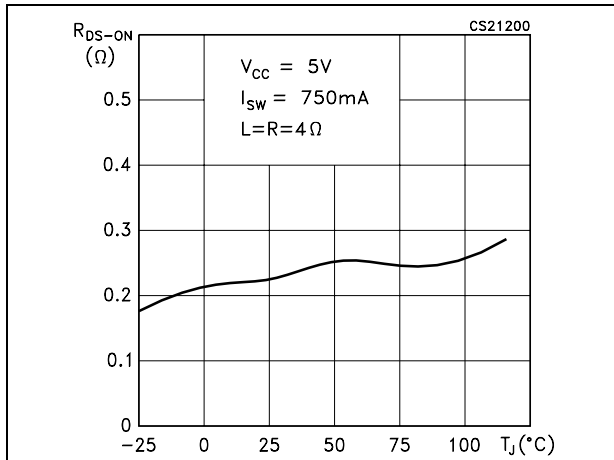

Figure 17. Switch current limitation vs temperature

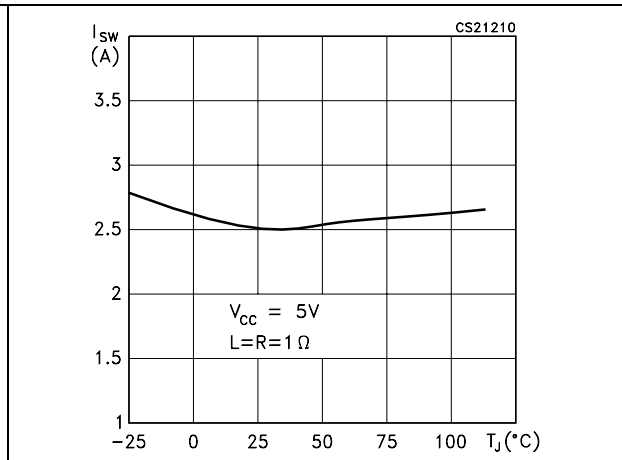

Figure 18. Load transient response

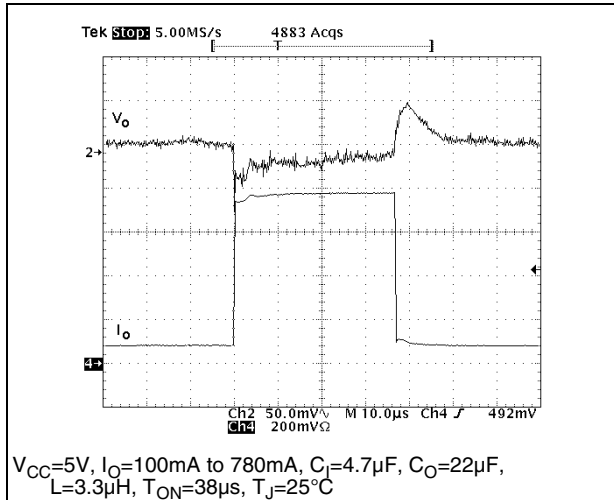

Figure 19. Load transient response

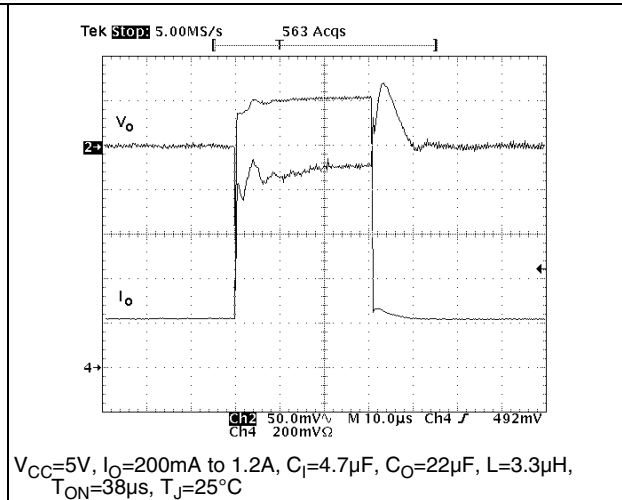

Figure 20. Start-Up transient

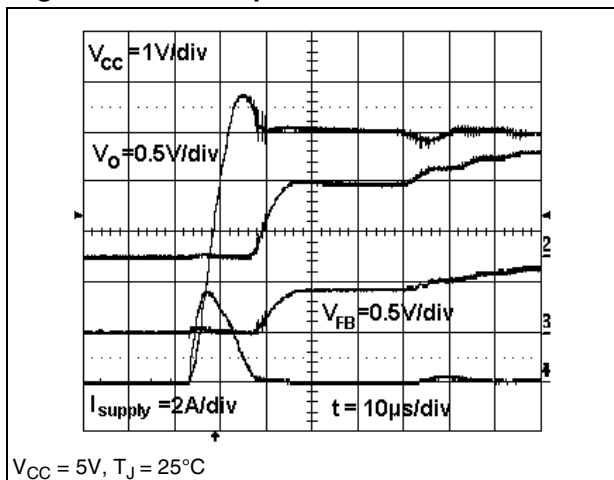
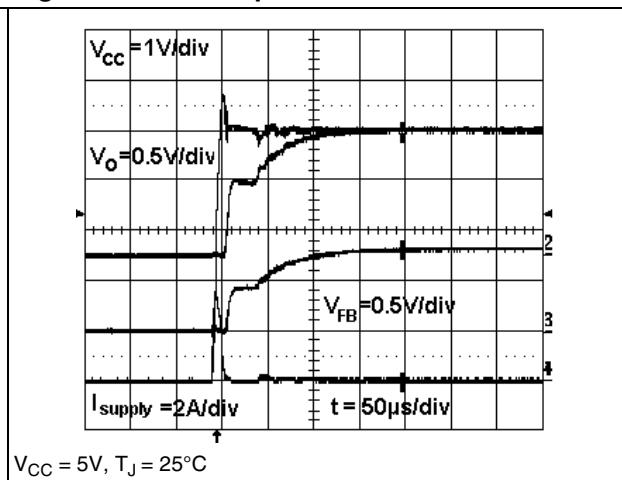

Figure 21. Start-Up transient



8 Package mechanical data

In order to meet environmental requirements, ST offers these devices in ECOPACK® packages. These packages have a Lead-free second level interconnect. The category of second Level Interconnect is marked on the package and on the inner box label, in compliance with JEDEC Standard JESD97. The maximum ratings related to soldering conditions are also marked on the inner box label. ECOPACK is an ST trademark. ECOPACK specifications are available at: www.st.com.

DFN6 (3x3) MECHANICAL DATA

DIM.	mm.			inch.		
	MIN.	TYP	MAX.	MIN.	TYP.	MAX.
A	0.80		1.00	0.031		0.039
A1	0		0.05	0.0		0.02
A2	0.65		0.75	0.026		0.030
A3		0.20			0.08	
b	0.33		0.43	0.013		0.017
D	2.90	3.00	3.10	0.114	0.118	0.122
D2	1.92		2.12	0.076		0.083
E	2.90	3.00	3.10	0.114	0.118	0.122
E2	1.11		1.31	0.044		0.052
e		0.95			0.037	
L	0.20		0.45	0.008		0.018
L1		0.24			0.009	
L2			0.13			0.005
K	0.20			0.008		

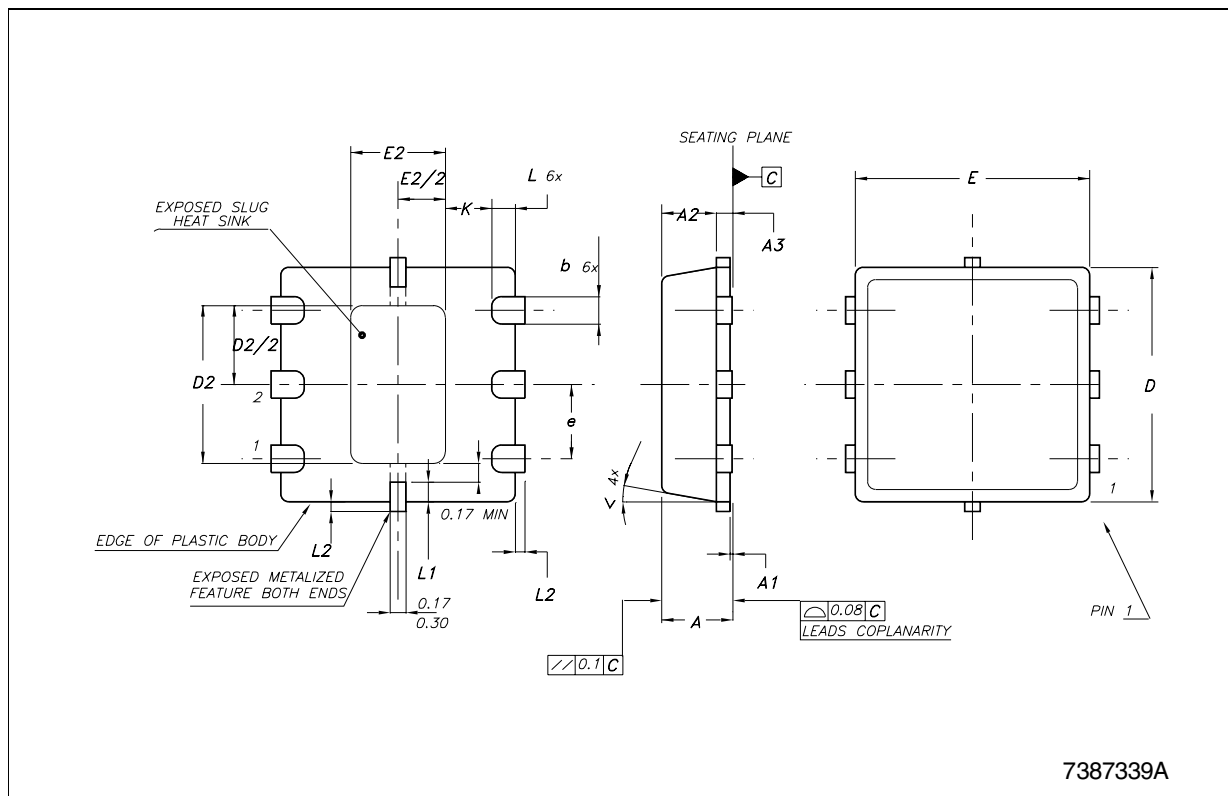

DFN6D (3x3) MECHANICAL DATA

DIM.	mm.			inch		
	MIN.	TYP	MAX.	MIN.	TYP.	MAX.
A	0.80		1.00	0.031		0.039
A1	0	0.02	0.05	0	0.001	0.002
A3		0.20			0.008	
b	0.23		0.45	0.009		0.018
D	2.90	3.00	3.10	0.114	0.118	0.122
D2	2.23		2.50	0.088		0.098
E	2.90	3.00	3.10	0.114	0.118	0.122
E2	1.50		1.75	0.059		0.069
e		0.95			0.037	
L	0.30	0.40	0.50	0.012	0.016	0.020

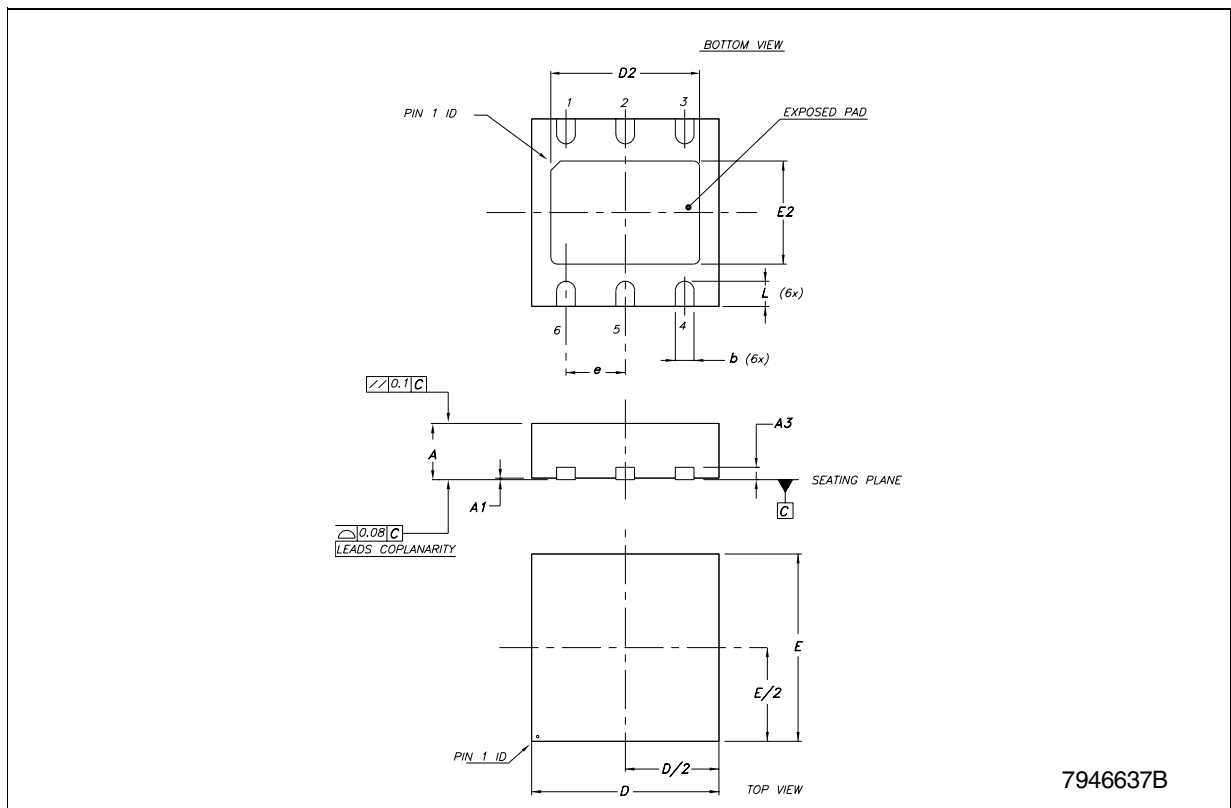

Tape & Reel QFNxx/DFNxx (3x3) MECHANICAL DATA

DIM.	mm.			inch		
	MIN.	TYP	MAX.	MIN.	TYP.	MAX.
A			330			12.992
C	12.8		13.2	0.504		0.519
D	20.2			0.795		
N	60			2.362		
T			18.4			0.724
Ao		3.3			0.130	
Bo		3.3			0.130	
Ko		1.1			0.043	
Po		4			0.157	
P		8			0.315	

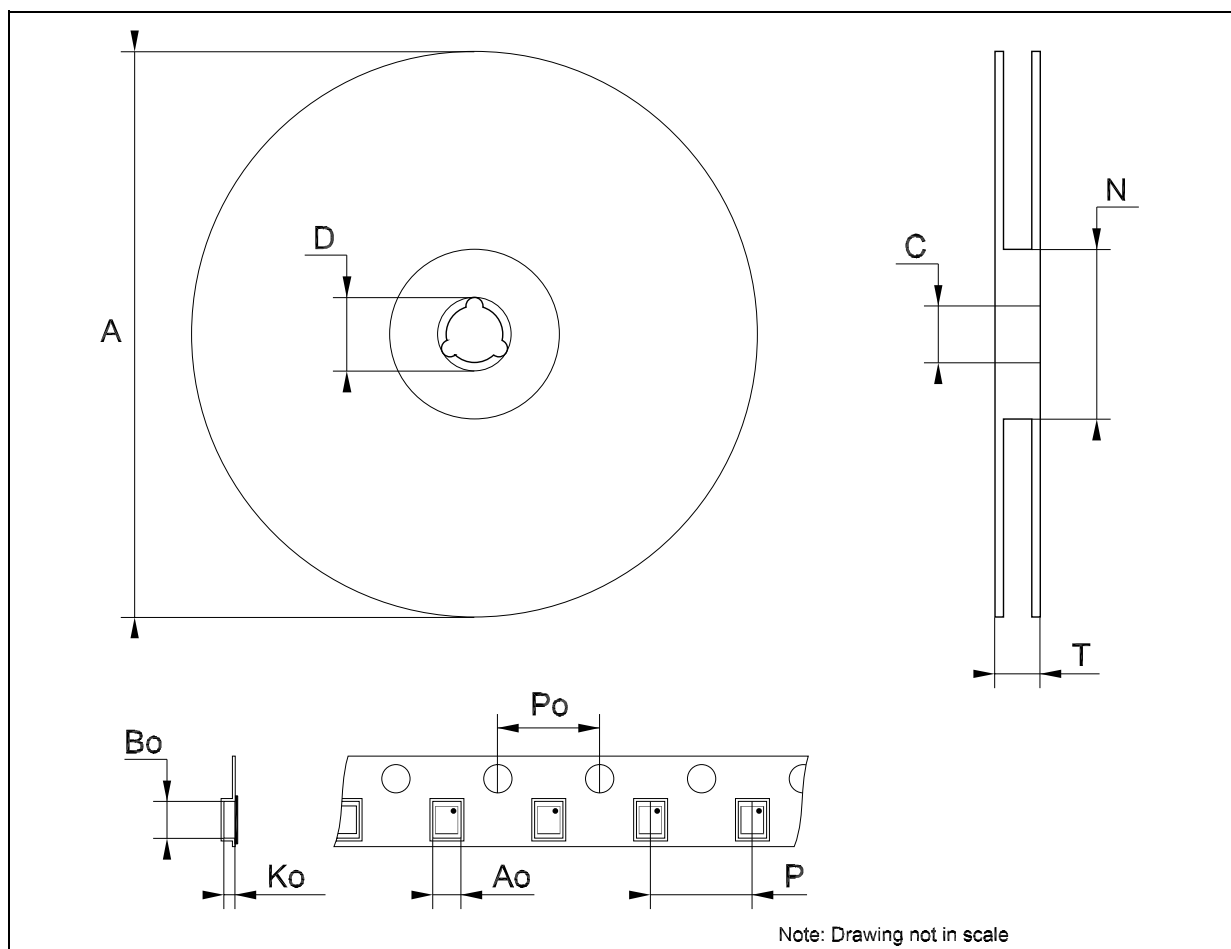

9 Revision history

Table 5. Revision history

Date	Revision	Changes
11-Nov-2004	1	First Release.
08-Feb-2005	2	Maturity Change.
03-Mar-2005	3	Mistake on Figure 1, T_J is changed 125 ==> 150°C on Table 3.
13-Jul-2005	4	Add new package SO-8 exposed pad.
29-Mar-2007	5	Package SO-8 has been removed and the document has been reformatted.

Please Read Carefully:

Information in this document is provided solely in connection with ST products. STMicroelectronics NV and its subsidiaries ("ST") reserve the right to make changes, corrections, modifications or improvements, to this document, and the products and services described herein at any time, without notice.

All ST products are sold pursuant to ST's terms and conditions of sale.

Purchasers are solely responsible for the choice, selection and use of the ST products and services described herein, and ST assumes no liability whatsoever relating to the choice, selection or use of the ST products and services described herein.

No license, express or implied, by estoppel or otherwise, to any intellectual property rights is granted under this document. If any part of this document refers to any third party products or services it shall not be deemed a license grant by ST for the use of such third party products or services, or any intellectual property contained therein or considered as a warranty covering the use in any manner whatsoever of such third party products or services or any intellectual property contained therein.

UNLESS OTHERWISE SET FORTH IN ST'S TERMS AND CONDITIONS OF SALE ST DISCLAIMS ANY EXPRESS OR IMPLIED WARRANTY WITH RESPECT TO THE USE AND/OR SALE OF ST PRODUCTS INCLUDING WITHOUT LIMITATION IMPLIED WARRANTIES OF MERCHANTABILITY, FITNESS FOR A PARTICULAR PURPOSE (AND THEIR EQUIVALENTS UNDER THE LAWS OF ANY JURISDICTION), OR INFRINGEMENT OF ANY PATENT, COPYRIGHT OR OTHER INTELLECTUAL PROPERTY RIGHT.

UNLESS EXPRESSLY APPROVED IN WRITING BY AN AUTHORIZED ST REPRESENTATIVE, ST PRODUCTS ARE NOT RECOMMENDED, AUTHORIZED OR WARRANTED FOR USE IN MILITARY, AIR CRAFT, SPACE, LIFE SAVING, OR LIFE SUSTAINING APPLICATIONS, NOR IN PRODUCTS OR SYSTEMS WHERE FAILURE OR MALFUNCTION MAY RESULT IN PERSONAL INJURY, DEATH, OR SEVERE PROPERTY OR ENVIRONMENTAL DAMAGE. ST PRODUCTS WHICH ARE NOT SPECIFIED AS "AUTOMOTIVE GRADE" MAY ONLY BE USED IN AUTOMOTIVE APPLICATIONS AT USER'S OWN RISK.

Resale of ST products with provisions different from the statements and/or technical features set forth in this document shall immediately void any warranty granted by ST for the ST product or service described herein and shall not create or extend in any manner whatsoever, any liability of ST.

ST and the ST logo are trademarks or registered trademarks of ST in various countries.

Information in this document supersedes and replaces all information previously supplied.

The ST logo is a registered trademark of STMicroelectronics. All other names are the property of their respective owners.

© 2007 STMicroelectronics - All rights reserved

STMicroelectronics group of companies

Australia - Belgium - Brazil - Canada - China - Czech Republic - Finland - France - Germany - Hong Kong - India - Israel - Italy - Japan - Malaysia - Malta - Morocco - Singapore - Spain - Sweden - Switzerland - United Kingdom - United States of America

www.st.com