

Low Power Half-Duplex RS-485 Transceivers

FEATURES

- +5V Only
- Low Power BiCMOS
- Driver / Receiver Enable
- Slew Rate Limited Driver for Low EMI (SP483)
- Low Power Shutdown mode (SP483)
- RS-485 and RS-422 Drivers/Receivers

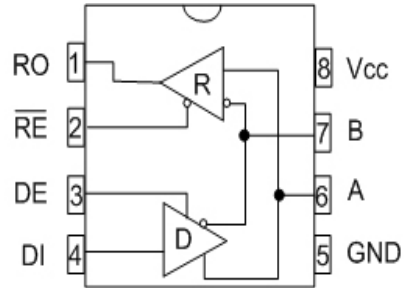

SP483,SP485
Pinout (Top View)

DESCRIPTION

The **SP483** and **SP485** are a family of half-duplex transceivers that meet the specifications of RS-485 and RS-422. Their BiCMOS design allows low power operation without sacrificing performance. The **SP485** meets the requirements of RS-485 and RS-422 up to 5Mbps. Additionally, the **SP483** is equipped with a low power Shutdown mode. The **SP483** is internally slew rate limited to reduce EMI and can meet the requirements of RS-485 and RS-422 up to 250kbps.

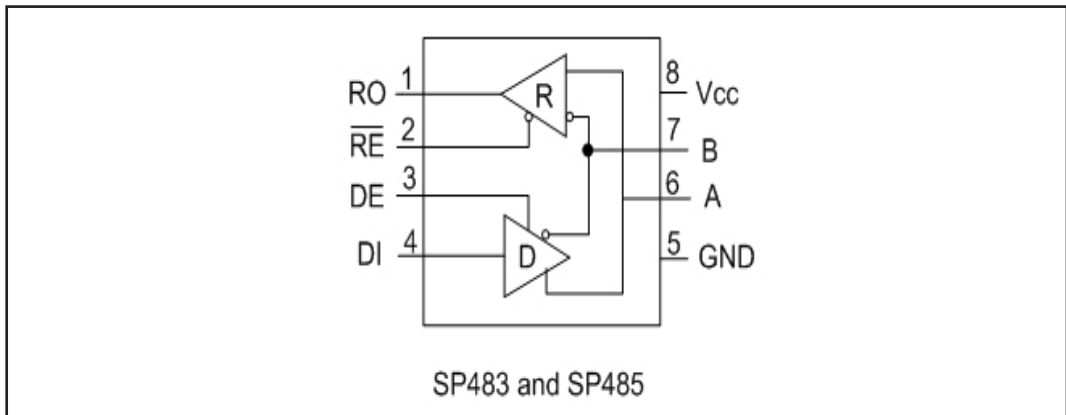

ABSOLUTE MAXIMUM RATINGS

These are stress ratings only and functional operation of the device at these ratings or any other above those indicated in the operation sections of the specifications below is not implied. Exposure to absolute maximum rating conditions for extended periods of time may affect reliability.

V _{CC}	+7V
Input Voltages	
Logic.....	-0.3V to (V _{CC} + 0.5V)
Drivers.....	-0.3V to (V _{CC} + 0.5V)
Receivers.....	+/-15V

Outputs

Logic.....	-0.3V to (V _{CC} + 0.5V)
Drivers.....	+/-15V
Receivers.....	-0.3V to (V _{CC} + 0.5V)
Receiver Output Current.....	+/-95mA

Storage Temperature.....-65°C to +150°C

Power Dissipation

8-pin NSOIC.....500mW

Thermal Information

θ_{JA}.....105.44°C/W

θ_{JC}.....51.34°C/W

ELECTRICAL CHARACTERISTICS

T_{MIN} to T_{MAX} and V_{CC} = 5V +/-5% unless otherwise noted.

PARAMETERS	MIN.	TYP.	MAX.	UNITS	CONDITIONS
SP483/SP485 DRIVER					
DC Characteristics					
Differential Output Voltage			V _{CC}	Volts	Unloaded; R = ∞ ; see figure 1
Differential Output Voltage	2		V _{CC}	Volts	With Load; R = 50Ω (RS-422); see figure 1
Differential Output Voltage	1.5		V _{CC}	Volts	With Load; R = 27Ω (RS-485); see figure 1
Change in Magnitude of Driver Differential Output Voltage for Complimentary states			0.2	Volts	R = 27Ω or R = 50Ω; see figure 1
Driver Common Mode Output Voltage			3	Volts	R = 27Ω or R = 50Ω; see figure 1
Input High Voltage	2.0			Volts	Applies to DE, DI, \overline{RE}
Input Low Voltage			0.8	Volts	Applies to DE, DI, \overline{RE}
Input Current			+/-10	μA	Applies to DE, DI, \overline{RE}
Driver Short Circuit Current, V _{OUT} = HIGH			250	mA	-7V ≤ V _O ≤ +12V
Driver Short Circuit Current, V _{OUT} = LOW			250	mA	-7V ≤ V _O ≤ +12V
SP485 DRIVER					
AC Characteristics					
Maximum Data Rate	5			Mbps	\overline{RE} = 5V, DE = 5V
Driver Input to Output, t _{PLH}		30	60	ns	Figures 3 and 5, R _{DIFF} = 54Ω, C _{L1} = C _{L2} = 100pF
Driver Input to Output, t _{PHL}		30	60	ns	Figures 3 and 5, R _{DIFF} = 54Ω, C _{L1} = C _{L2} = 100pF
Driver Skew		5	10	ns	Figures 3 and 5, t _{SKREW} = t _{DPHL} - t _{DPLH}
Driver Rise or Fall Time		15	40	ns	From 10%-90%; R _{DIFF} = 54Ω, C _{L1} = C _{L2} = 100pF; see figures 3 and 5

ELECTRICAL CHARACTERISTICS

T_{MIN} to T_{MAX} and $V_{CC} = 5V \pm 5\%$ unless otherwise noted.

PARAMETERS	MIN.	TYP.	MAX.	UNITS	CONDITIONS
SP485 DRIVER (continued)					
AC Characteristics					
Driver Enable to Output High		40	70	ns	$C_L = 100\text{pF}$, see figures 4 and 6, S_2 closed
Driver Enable to Output Low		40	70	ns	$C_L = 100\text{pF}$, see figures 4 and 6, S_1 closed
Driver Disable Time from High		40	70	ns	$C_L = 15\text{pF}$, see figures 2 and 8, S_2 closed
Driver Disable Time from Low		40	70	ns	$C_L = 15\text{pF}$, see figures 2 and 8, S_1 closed
SP483/SP485 RECEIVER					
DC Characteristics					
Differential Input Threshold	-0.2		+0.2	Volts	$-7V \leq V_{CM} \leq +12V$
Input Hysteresis		10		mV	$V_{CM} = 0V$
Output Voltage High	2.4		5	Volts	$I_O = -4\text{mA}$, $V_{ID} = +200\text{mV}$
Output Voltage Low	0.0		0.4	Volts	$I_O = +4\text{mA}$, $V_{ID} = -200\text{mV}$
Three-State (High Impedance) Output Current			+/-1	μA	$0.4V \leq V_O \leq 2.4V$; $\overline{RE} = 5V$
Input Resistance	12	15		k Ω	$-7V \leq V_{CM} \leq +12V$
Input Current (A, B); $V_{IN} = 12V$			+1.0	mA	$DE = 0V$, $V_{CC} = 0V$ or $5.25V$, $V_{IN} = 12V$
Input Current (A, B); $V_{IN} = -7V$			-0.8	mA	$DE = 0V$, $V_{CC} = 0V$ or $5.25V$, $V_{IN} = -7V$
SP485 RECEIVER					
AC Characteristics					
Maximum Data Rate	5			Mbps	$\overline{RE} = 0V$, $DE = 0V$
Receiver Input to Output	20	45	200	ns	t_{PLH} : Figures 3 and 7, $R_{DIFF} = 54\Omega$, $C_{L1} = C_{L2} = 100\text{pF}$
Receiver Input to Output	20	45	200	ns	t_{PHL} : Figures 3 and 7, $R_{DIFF} = 54\Omega$, $C_{L1} = C_{L2} = 100\text{pF}$
Differential Receiver Skew $ t_{PHL} - t_{PLH} $		13		ns	$R_{DIFF} = 54\Omega$, $C_{L1} = C_{L2} = 100\text{pF}$, Figures 3 and 7
Receiver Enable to Output Low		45	70	ns	$C_{RL} = 15\text{pF}$, Figures 2 and 8; S_1 Closed
Receiver Enable to Output High		45	70	ns	$C_{RL} = 15\text{pF}$, Figures 2 and 8; S_2 Closed
Receiver Disable from LOW		45	70	ns	$C_{RL} = 15\text{pF}$, Figures 2 and 8; S_1 Closed
Receiver Disable from High		45	70	ns	$C_{RL} = 15\text{pF}$, Figures 2 and 8; S_2 Closed

ELECTRICAL CHARACTERISTICS

T_{MIN} to T_{MAX} and $V_{CC} = 5V \pm 5\%$ unless otherwise noted.

PARAMETERS	MIN.	TYP.	MAX.	UNITS	CONDITIONS
POWER REQUIREMENTS					
Supply Voltage V_{CC}	+4.75		+5.25	Volts	
Supply Current					
SP485		900		μA	No Load; \overline{RE} , DI = 0V or V_{CC} ; DE = V_{CC}
		900		μA	No Load; $\overline{RE} = 0V$, DI = 0V or 5V; DE = 0V
SP483		600		μA	No Load; \overline{RE} , DI = 0V or V_{CC} ; DE = V_{CC}
		600		μA	No Load; $\overline{RE} = 0V$, DI = 0V or 5V; DE = 0V
SP483			10	μA	Shutdown Mode; DE = 0V, $\overline{RE} = V_{CC}$
ENVIRONMENTAL AND MECHANICAL					
Operating Temperature					
Commercial (<u>C</u>)	0		70	$^{\circ}C$	
Industrial (<u>E</u>)	-40		+85	$^{\circ}C$	
Storage Temperature	-65		+150	$^{\circ}C$	
Package: Plastic DIP (<u>P</u>), NSOIC (<u>N</u>)					

ELECTRICAL CHARACTERISTICS

T_{MIN} to T_{MAX} and $V_{CC} = 5V \pm 5\%$ unless otherwise noted.

PARAMETERS	MIN.	TYP.	MAX.	UNITS	CONDITIONS
SP483 DRIVER					
AC Characteristics					
Maximum Data Rate	250			kbps	
Driver Input to Output, t_{PLH}	250	800	2000	ns	t_{PLH} ; $R_{DIFF} = 54\Omega$, $C_{L1} = C_{L2} = 100pF$, see figures 3 and 5
Driver Input to Output, t_{PHL}	250	800	2000	ns	t_{PHL} ; $R_{DIFF} = 54\Omega$, $C_{L1} = C_{L2} = 100pF$, see figures 3 and 5
Driver Skew		100	800	ns	see figures 3 and 5, $t_{SKEW} = t_{DPHL} - t_{DPLH} $
Driver Rise or Fall Time	250		2000	ns	From 10%-90%; $R_{DIFF} = 54\Omega$ $C_{L1} = C_{L2} = 100pF$; see Figures 3 and 5
Driver Enable to Output High	250		2000	ns	$C_L = 100pF$, see figures 4 and 6, S_2 closed
Driver Enable to Output Low	250		2000	ns	$C_L = 100pF$, see figures 4 and 6, S_1 closed
Driver Disable Time from High	300		3000	ns	$C_L = 15pF$, see figures 4 and 6, S_2 closed
Driver Disable Time from Low	300		3000	ns	$C_L = 15pF$, see figures 4 and 6, S_1 closed
SP483 RECEIVER					
AC Characteristics					
Maximum Data Rate	250			kbps	
Receiver Input to Output	250		2000	ns	t_{PLH} , t_{PHL} ; Figures 3 and 7: $R_{DIFF} = 54\Omega$, $C_{L1} = C_{L2} = 100pF$
Differential Receiver Skew $ t_{PHL} - t_{PLH} $		100		ns	$R_{DIFF} = 54\Omega$, $C_{L1} = C_{L2} = 100pF$, see Figures 3 and 7
Receiver Enable to Output Low		20	50	ns	$C_{RL} = 15pF$, Figures 2 and 8; S_1 Closed
Receiver Enable to Output High		20	50	ns	$C_{RL} = 15pF$, Figures 2 and 8; S_2 Closed
Receiver Disable from LOW		20	50	ns	$C_{RL} = 15pF$, Figures 2 and 8; S_1 Closed
Receiver Disable from High		20	50	ns	$C_{RL} = 15pF$, Figures 2 and 8; S_2 Closed
SP483					
Shutdown Timing					
Time to Shutdown	50	200	600	ns	$\overline{RE} = 5V$, $DE = 0V$
Driver Enable from Shutdown to Output High			2000	ns	$C_L = 100pF$; See Figures 4 and 6; S_2 Closed
Driver Enable from Shutdown to Output Low			2000	ns	$C_L = 100pF$; See Figures 4 and 6; S_1 Closed
Receiver Enable from Shutdown to Output High			2500	ns	$C_L = 15pF$; See Figures 4 and 6; S_2 Closed
Receiver Enable from Shutdown to Output Low			2500	ns	$C_L = 15pF$; See Figures 4 and 6; S_1 Closed

PIN FUNCTION

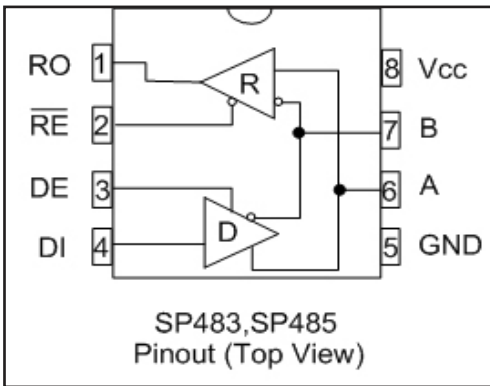

Pin 1 - RO - Receiver Output

Pin 2 - \overline{RE} - Receiver Output Enable Active LOW

Pin 3 - DE - Driver Output Enable Active HIGH

Pin 4 - DI - Driver Input

Pin 5 - GND - Ground Connection

Pin 6 - A - Driver Output / Receiver input
Non-Inverting

Pin 7 - B - Driver Output / Receiver Input Inverting

Pin 8 - V_{CC} - Positive Supply $4.75V \leq V_{CC} \leq 5.25V$

TEST CIRCUITS

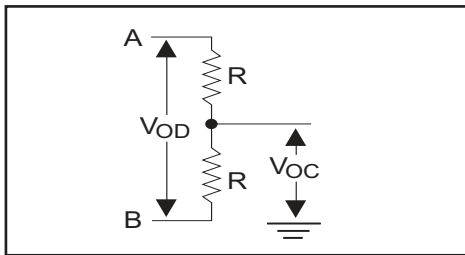

Figure 1. Driver DC Test Load Circuit

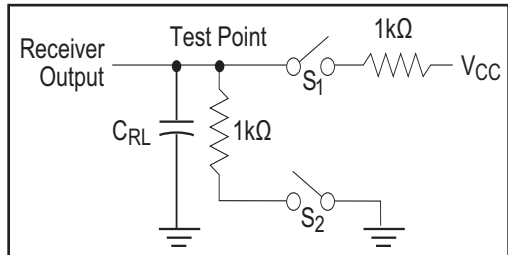

Figure 2. Receiver Timing Test Load Circuit

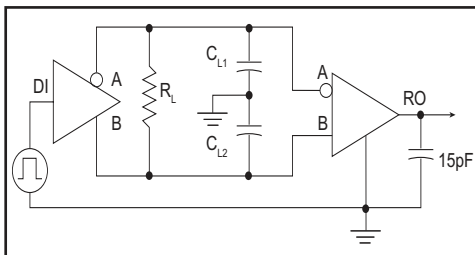

Figure 3. RS-485 Driver/Receiver Timing Test

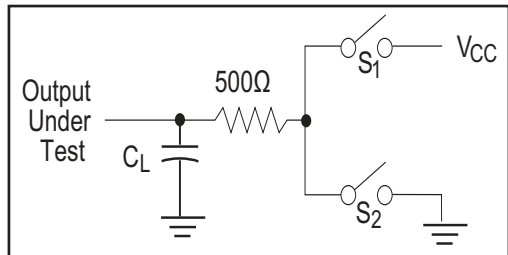

Figure 4. Driver Timing Test Load #2 Circuit

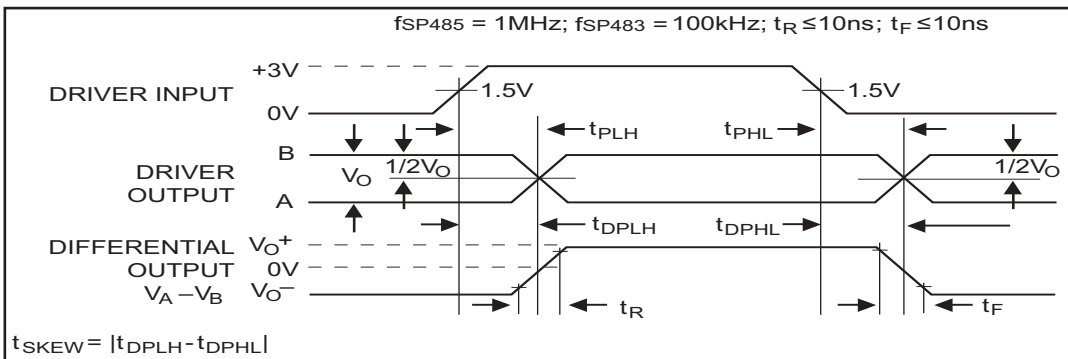

Figure 5. Driver Propagation Delays

FUNCTION TRUTH TABLES

INPUTS			LINE CONDITION	OUTPUTS	
\overline{RE}	DE	DI		A	B
X	1	1	No Fault	1	0
X	1	0	No Fault	0	1
X	0	X	X	Z	Z
X	1	X	Fault	Z	Z

Table 1. Transmit Function Truth Table

INPUTS			A - B	OUTPUTS
\overline{RE}	DE			
0	0		+0.2V	1
0	0		-0.2V	0
0	0		Inputs Open	1
1	0		X	Z

Table 2. Receive Function Truth Table

SWITCHING WAVEFORMS

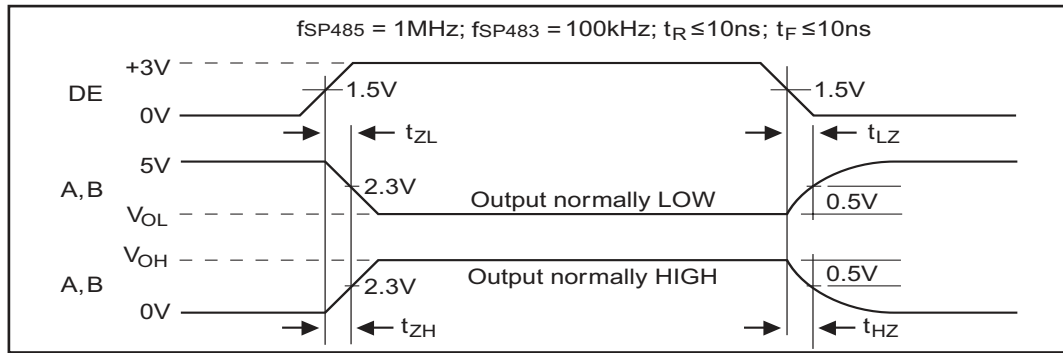

Figure 6. Driver Enable and Disable Times

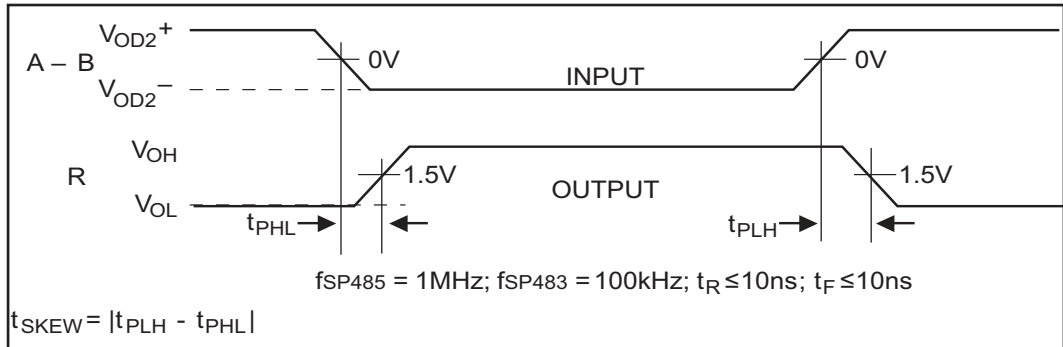

Figure 7. Receiver Propagation Delays

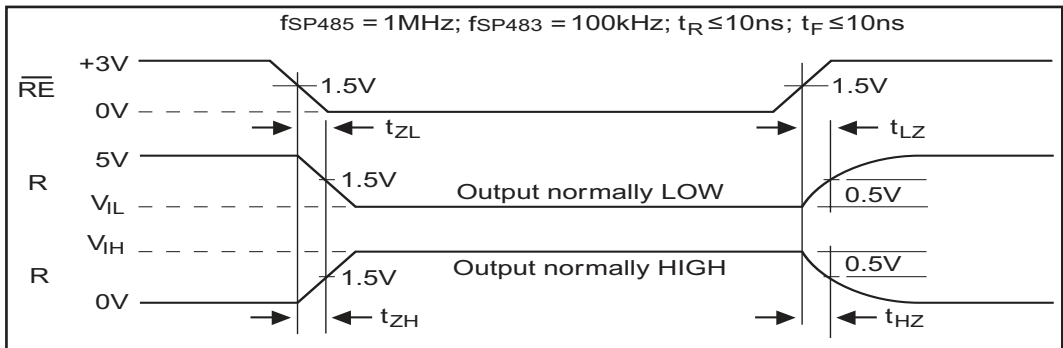

Figure 8. Receiver Enable and Disable Times

The **SP483** and **SP485** are half-duplex differential transceivers that meet the requirements of RS-485 and RS-422. Fabricated with an **Exar** proprietary BiCMOS process, this product requires a fraction of the power of older bipolar designs.

The RS-485 standard is ideal for multi-drop applications and for long-distance interfaces. RS-485 allows up to 32 drivers and 32 receivers to be connected to a data bus, making it an ideal choice for multi-drop applications. Since the cabling can be as long as 4,000 feet, RS-485 transceivers are equipped with a wide (-7V to +12V) common mode range to accommodate ground potential differences. Because RS-485 is a differential interface, data is virtually immune to noise in the transmission line.

Drivers

SP483 and SP485

The driver outputs of the **SP483** and **SP485** are differential outputs meeting the RS-485 and RS-422 standards. The typical voltage output swing with no load will be 0 Volts to +5 Volts. With worst case loading of 54Ω across the differential outputs, the drivers can maintain greater than 1.5V voltage levels. The drivers of the **SP483** and **SP485** have an enable control line which is active HIGH. A logic HIGH on DE (pin 3) will enable the differential driver outputs. A logic LOW on the DE (pin 3) will tri-state the driver outputs.

The transmitters of the **SP485** will operate up to at least 5Mbps. The **SP483** has internally slew rate limited driver outputs to minimize EMI. The maximum data rate for the **SP483** driver is 250kbps.

Receivers

SP483 and SP485

The **SP483** and **SP485** receivers have differential inputs with an input sensitivity as low as ±200mV. Input impedance of the receivers is typically 15kΩ (12kΩ minimum). A wide common mode range of -7V to +12V allows for large ground potential differences between systems. The receivers of the **SP483** and **SP485** have a tri-state enable control pin. A logic LOW on \overline{RE} (pin 2) will enable the receiver, a logic HIGH on \overline{RE} (pin 2) will disable the receiver.

The receiver for the **SP485** will operate up to at least 10Mbps. The **SP483** receiver is rated for data rates up to 250kbps. The receiver for each of the three devices is equipped with the fail-safe feature. Fail-safe guarantees that the receiver output will be in a HIGH state when the input is left unconnected and floating.

Shutdown Mode

SP483

The **SP483** is equipped with a Shutdown mode. To enable the shutdown state, both driver and receiver must be disabled simultaneously. A logic LOW on DE (pin 3) and a Logic HIGH on \overline{RE} (pin 2) will put the **SP483** into Shutdown mode. In Shutdown, supply current will drop to typically 1μA.

MECHANICAL DIMENSIONS (8 PIN NSOIC)

Top View

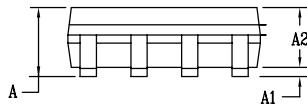
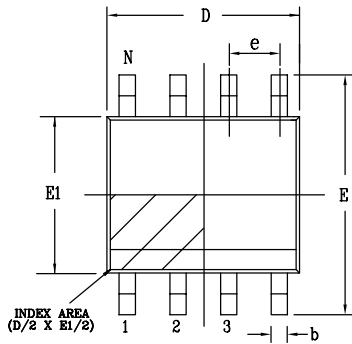

Side View

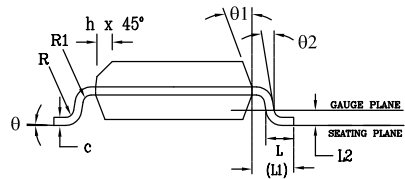

Front View

PACKAGE OUTLINE NSOIC .150" BODY JEDEC MS-012 VARIATION AA						
SYMBOLS	COMMON DIMENSIONS IN MM (Control Unit)			COMMON DIMENSIONS IN INCH (Reference Unit)		
	MIN	NOM	MAX	MIN	NOM	MAX
A	1.35	—	1.75	0.053	—	0.069
A1	0.10	—	0.25	0.004	—	0.010
A2	1.25	—	1.65	0.049	—	0.065
b	0.31	—	0.51	0.012	—	0.020
c	0.17	—	0.25	0.007	—	0.010
E	6.00 BSC			0.236 BSC		
E1	3.90 BSC			0.154 BSC		
e	1.27 BSC			0.050 BSC		
h	0.25	—	0.50	0.010	—	0.020
L	0.40	—	1.27	0.016	—	0.050
L1	1.04 REF			0.041 REF		
L2	0.25 BSC			0.010 BSC		
R	0.07	—	—	0.003	—	—
R1	0.07	—	—	0.003	—	—
q	0°	—	8°	0°	—	8°
q1	5°	—	15°	5°	—	15°
q2	0°	—	—	0°	—	—
D	4.90 BSC			0.193 BSC		
N	—			8		

Drawing No: POD-00000108

Revision: A

MECHANICAL DIMENSIONS (8 PIN PDIP)
8 PIN PDIP VERSIONS OBSOLETE

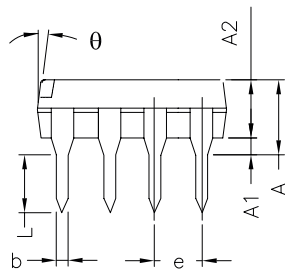
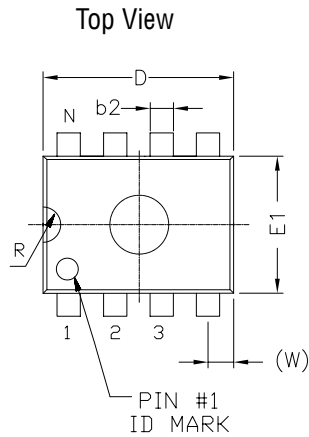

Side View

REMARKS:
 ALL END LEADS (4X)
 ARE HALF LEAD TYPES

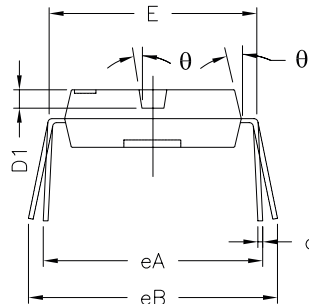
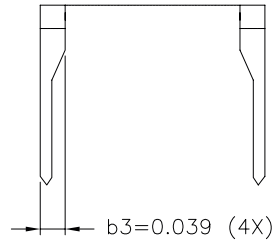

Front View

8 Pin PDIP JEDEC MS-001 Variation BA						
SYMBOLS	DIMENSIONS IN INCH (Control Unit)			DIMENSIONS IN MM (Reference Unit)		
	MIN	NOM	MAX	MIN	NOM	MAX
A	—	—	0.210	—	—	5.33
A1	0.015	—	—	0.38	—	—
A2	0.115	0.130	0.195	2.92	3.30	4.95
b	0.014	0.018	0.022	0.36	0.46	0.56
b2	0.045	0.060	0.070	1.14	1.52	1.78
c	0.008	0.010	0.014	0.20	0.25	0.36
D1	0.030	—	0.060	0.76	—	1.52
E	0.300	0.310	0.325	7.62	7.87	8.26
E1	0.240	0.250	0.280	6.10	6.35	7.11
e	0.100 BSC			2.54 BSC		
eA	0.300 BSC			7.62 BSC		
eB	—	—	0.430	—	—	10.92
L	0.115	0.130	0.150	2.92	3.30	3.81
W	0.075 REF			1.91 REF		
R	0.030 BSC			0.76 BSC		
theta	4°	7°	10°	4°	7°	10°
D	0.355	0.365	0.400	9.02	9.27	10.16
N	8			8		

Drawing No: POD-0000111

Revision: A

ORDERING INFORMATION

Part Number	Temperature Range	Package	Package Method	Lead-Free
SP483				
SP483CN-L	0°C to +70°C	8-pin NSOIC	Tube	Yes
SP483CN-L/TR	0°C to +70°C	8-pin NSOIC	Tape and Reel	Yes
SP483EN-L/TR	-40°C to +85°C	8-pin NSOIC	Tape and Reel	Yes
SP485				
SP485CN-L	0°C to +70°C	8-pin NSOIC	Tube	Yes
SP485CN-L/TR	0°C to +70°C	8-pin NSOIC	Tape and Reel	Yes
SP485EN-L	-40°C to +85°C	8-pin NSOIC	Tube	Yes
SP485EN-L/TR	-40°C to +85°C	8-pin NSOIC	Tape and Reel	Yes

NOTE: For more information about part numbers, as well as the most up-to-date ordering information and additional information on environmental rating, go to www.maxlinear.com/SP483 and www.maxlinear.com/SP485.

REVISION HISTORY

DATE	REVISION	DESCRIPTION
07/28/04	--	Legacy Sipex Datasheet
07/14/10	1.0.0	Convert to Exar Format. Update ordering information as a result of discontinued Lead type package options per PDN 081126-01. Remove all options and reference to SP481; Part is EOL. Remove "GND" entry from Minimum column of SP483/485 driver DC Characteristic parameter "Differential output voltage - Unloaded".
June 2011	1.0.1	Remove Driver Short Circuit Current minimum. Change Vcc ABS MAX Rating from +12V to +7V. Add 12k ohm minimum value to receiver Input Resistance. Change SP485 receiver propagation delay MIN and TYP to 20 and 45ns respectively, receiver Enable and Disable TYP and MAX to 45 and 70ns respectively. Remove SP483CS-L and SP483ES-L ordering part number per PDN 110510-01.
August 2020	1.0.2	Update to MaxLinear logo. Update Ordering Information.
February 4, 2022	1.0.3	<p>Updated:</p> <ul style="list-style-type: none"> ▪ In the "Absolute Maximum Ratings" section, replaced "Output Voltages" with "Outputs". <p>Added:</p> <ul style="list-style-type: none"> ▪ In the "Absolute Maximum Ratings" section, "Receiver Output Current" parameter. <p>Removed:</p> <ul style="list-style-type: none"> ▪ In the "Electrical Characteristics" section, "Short-Circuit Current" parameter.
April 20, 2023	1.0.4	<p>Updated:</p> <ul style="list-style-type: none"> ▪ In the "Absolute Maximum Ratings" section, added "Thermal Information".



MaxLinear, Inc.:
5966 La Place Court, Suite 100
Carlsbad, CA 92008
Tel.: +1 (760) 692-0711
Fax: +1 (760) 444-8598

www.maxlinear.com

The content of this document is furnished for informational use only, is subject to change without notice, and should not be construed as a commitment by MaxLinear, Inc. MaxLinear, Inc. assumes no responsibility or liability for any errors or inaccuracies that may appear in the informational content contained in this document. Complying with all applicable copyright laws is the responsibility of the user. Without limiting the rights under copyright, no part of this document may be reproduced into, stored in, or introduced into a retrieval system, or transmitted in any form or by any means (electronic, mechanical, photocopying, recording, or otherwise), or for any purpose, without the express written permission of MaxLinear, Inc.

EXCEPT AS OTHERWISE PROVIDED EXPRESSLY IN WRITING BY MAXLINEAR, AND TO THE MAXIMUM EXTENT PERMITTED BY LAW: (A) THE MAXLINEAR PRODUCTS ARE PROVIDED ON AN "AS IS" BASIS WITHOUT REPRESENTATIONS OR WARRANTIES OF ANY KIND, INCLUDING WITHOUT LIMITATION ANY IMPLIED OR STATUTORY WARRANTIES AND ANY WARRANTIES OF MERCHANTABILITY, FITNESS FOR A PARTICULAR PURPOSE, NON-INFRINGEMENT, OR TITLE; AND (B) MAXLINEAR DOES NOT GUARANTEE THAT THE PRODUCTS WILL BE FREE OF ERRORS OR DEFECTS. MAXLINEAR PRODUCTS SHOULD NOT BE USED IN ANY EMERGENCY, SECURITY, MILITARY, LIFE-SAVING, OR OTHER CRITICAL USE CASE WHERE A FAILURE OR MALFUNCTION COULD CAUSE PERSONAL INJURY OR DEATH, OR DAMAGE TO OR LOSS OF PROPERTY. USERS ASSUME ALL RISK FOR USING THE MAXLINEAR PRODUCTS IN SUCH USE CASE. CUSTOMERS AND USERS ARE SOLELY RESPONSIBLE FOR USING THEIR OWN SKILL AND JUDGMENT TO DETERMINE WHETHER MAXLINEAR PRODUCTS ARE SUITABLE FOR THE INTENDED USE CASE.

MaxLinear, Inc. may have patents, patent applications, trademarks, copyrights, or other intellectual property rights covering subject matter in this document. Except as expressly provided in any written license agreement from MaxLinear, Inc., the furnishing of this document does not give you any license to these patents, trademarks, copyrights, or other intellectual property.

MaxLinear, the MaxLinear logo, any other MaxLinear trademarks (including but not limited to MxL, Full-Spectrum Capture, FSC, AirPHY, Puma, AnyWAN, VectorBoost, MXL WARE, and Panther), and the MaxLinear logo on the products sold are all property of MaxLinear, Inc. or one of MaxLinear's subsidiaries in the U.S.A. and other countries. All rights reserved.

All third-party products, company names and logos are trademarks™ or registered® trademarks and remain the property of their respective holders/owners. Use of such marks does not imply any affiliation with, sponsorship or endorsement by the owners/holders of such trademarks. All references by MaxLinear to third party trademarks are intended to constitute nominative fair use under applicable trademark laws.

The URLs provided are for informational purposes only; they do not constitute an endorsement or an approval by MaxLinear of any of the products or services of the corporation or organization or individual. MaxLinear bears no responsibility for the accuracy, legality or content of the external site or for that of subsequent links. Contact the external site for answers to questions regarding its content.

© 2023 MaxLinear, Inc. All rights reserved