

REVISIONS					
P	LTR	DESCRIPTION	DATE	DMN	APVD
B4		REVISED PER ECR-19-007953	23MAY2019	SR	PO

SPECIFICATIONS
BREAK-BEFORE-MAKE

MATERIALS:
 ACTUATOR- THERMOPLASTIC, UL94HB
 TERMINAL BOARD- PHENOLIC LAMINATED SHEET, UL94HB, NATURAL
 FRAME- STEEL, NICKEL PLATE
 TERMINAL/FIXED CONTACT- COPPER ALLOY, GOLD OR SILVER OVER NICKEL PLATE
 MOVING CONTACT- COPPER ALLOY, GOLD OR SILVER OVER NICKEL PLATE
 DETENT BALL- STEEL
 COIL SPRING- GALVANIZED SPRING WIRE
 LEVER,(K SERIES ONLY)- ALUMINUM
 SEAL- EPOXY

ELECTRICAL:
 CONTACT RATING- .4VA@20VDC OR PEAK AC (GOLD); 300mA@125V AC (SILVER)
 INITIAL CONTACT RESISTANCE- 30 milliohm max.
 FINAL CONTACT RESISTANCE- 100 milliohm max. (AFTER TEST)
 INSULATION RESISTANCE- 1,000 Megohms min.
 DIELECTRIC STRENGTH- 500V RMS@SEA LEVEL
 LIFE EXPECTANCY- 15,000 CYCLES MIN.

MECHANICAL:
 ACTUATION FORCE- 600+/-300 GRAMS
 TRAVEL- SEE P/N TABLE

ENVIRONMENTAL:
 OPERATING TEMPERATURE- -20 TO +85 DEGREES C
 STORAGE TEMPERATURE- -40 TO +100 DEGREES C
 RESISTANCE TO SOLDER HEAT PER 109-202, CONDITION B
 SOLDERABILITY PER EIA-364-52, CLASS 2, CATEGORY 1, 95% MIN COVERAGE

NOTES:

- 1 COUNTRY OF ORIGIN AND TE CONNECTIVITY LOGO LOCATED APPROXIMATELY AS SHOWN
- 2 ALL MATERIALS AND FINISHES SHALL COMPLY WITH EU DIRECTIVE 2002/95/EC OF 27JAN2003 (ROHS)
- 3 ANTI SOLDER WICK SEAL AT TERMINAL TO BOARD INTERFACE
- 4 ALL PERFORMANCE TESTING WAS DONE IN ACCORDANCE TO TE CONNECTIVITY SPECIFICATION 102-2469
- 5 OBSOLETE PARTS: OBSOLETE CIS STREAMLINING PER D.RENAUD/D.SINISI

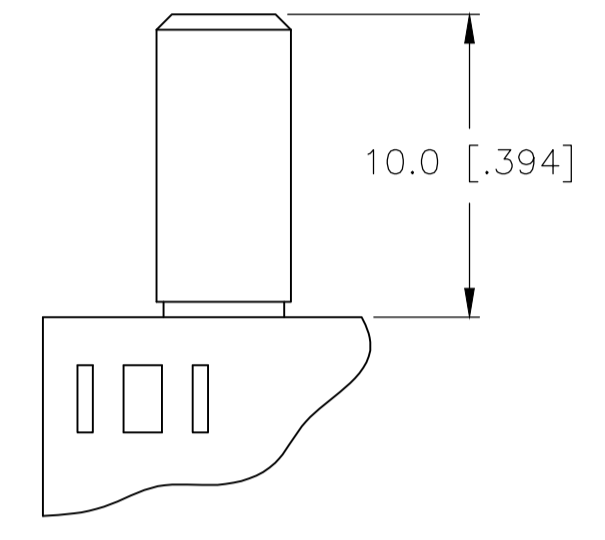
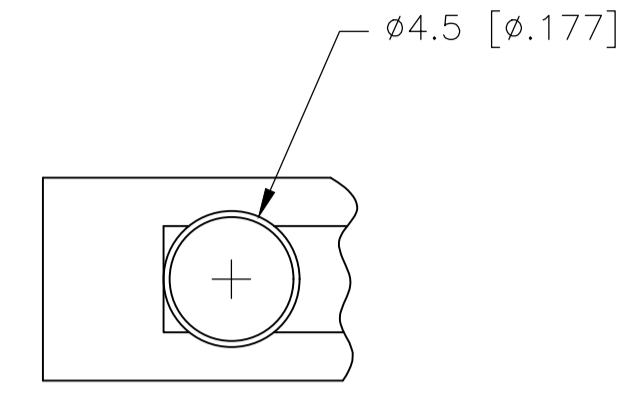
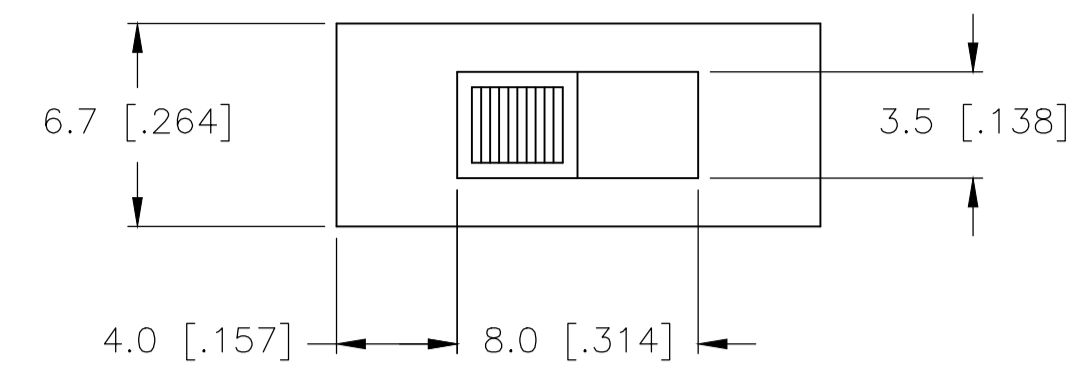

MHS222K & MHS223K LEVER

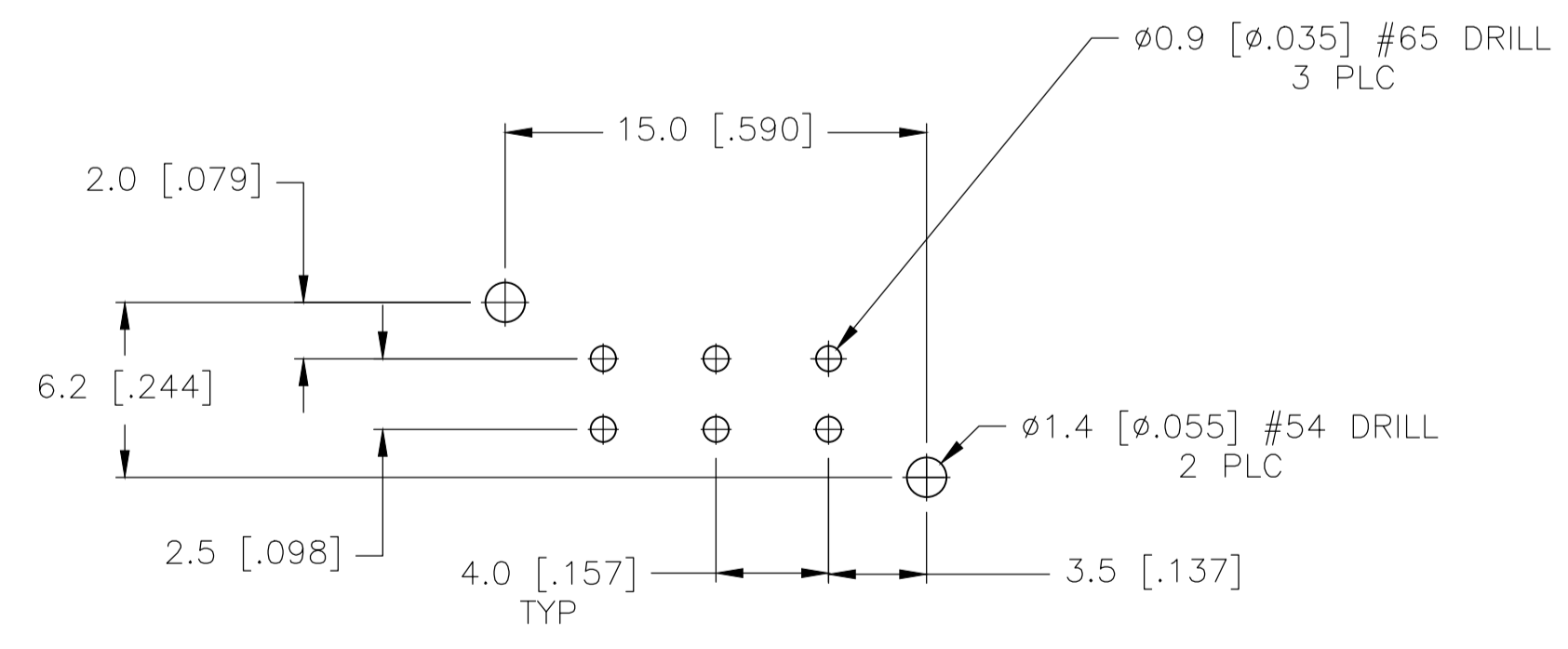
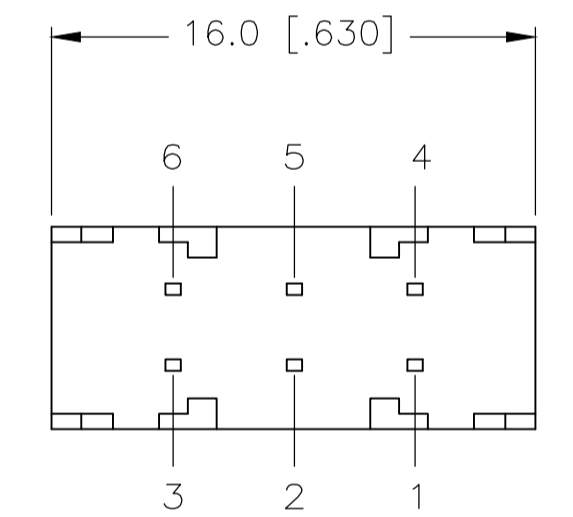
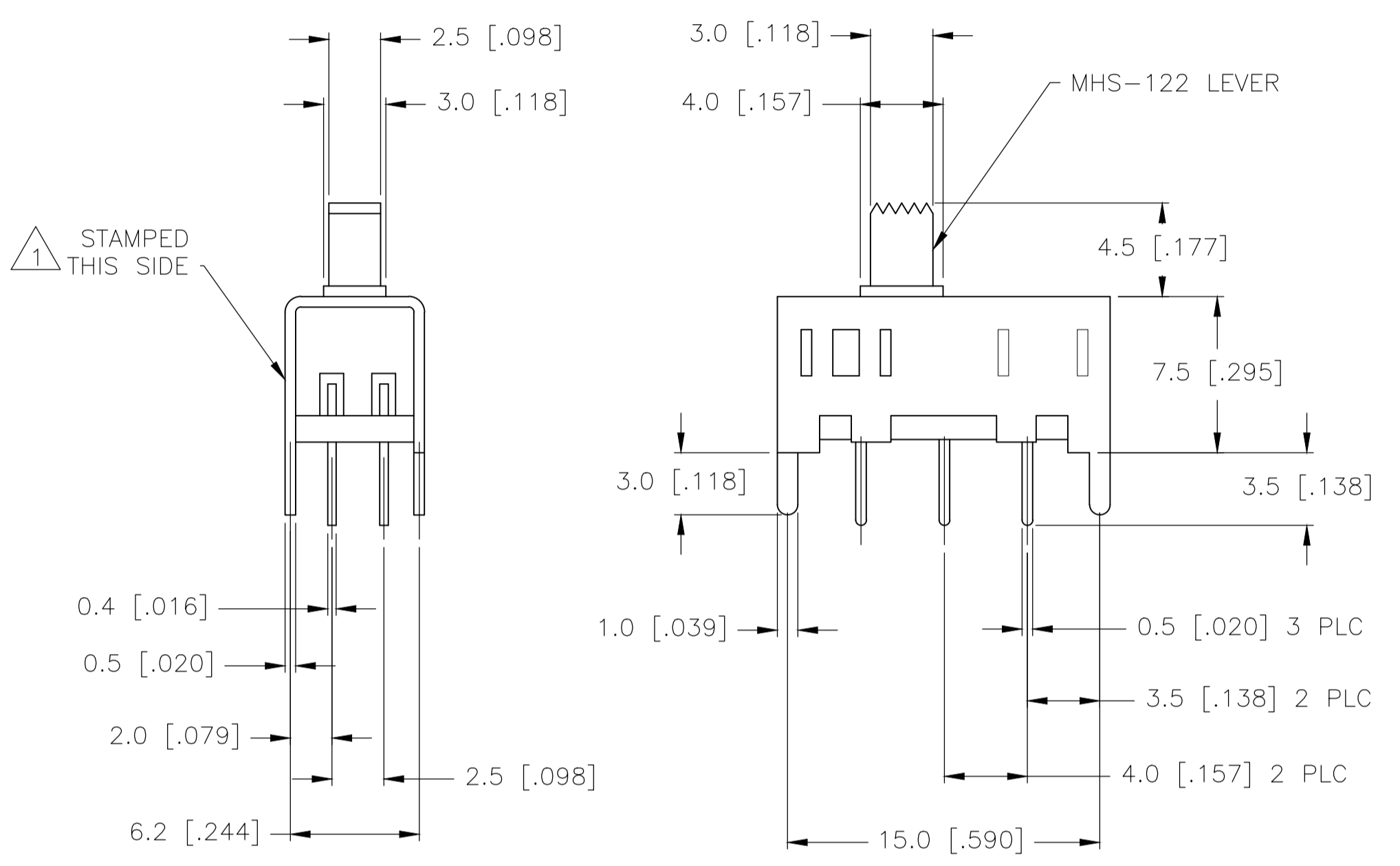

RECOMMENDED BOARD LAYOUT
PC LAYOUT TOLERANCE: ±.002

MHS222 & MHS223 SERIES SWITCH

OBSELETE	1-1825289-4	MHS233KG04	DP3T	2.00	GOLD	-	6-5 2-1	-	7-6 3-2	-	8-6 4-2
	1-1825289-0	MHS233K04	DP3T	2.00	SILVER	-	6-5 2-1	-	7-6 3-2	-	8-6 4-2
	1825289-9	MHS233G04	DP3T	2.00	GOLD	-	6-5 2-1	-	7-6 3-2	-	8-6 4-2
	1825289-8	MHS23304	DP3T	2.00	SILVER	-	6-5 2-1	-	7-6 3-2	-	8-6 4-2
	-	MHS223KG04	DPDT	2.00	GOLD	5-4 2-1	-	OFF	-	6-5 3-2	-
	1825289-7	MHS223K04	DPDT	2.00	SILVER	5-4 2-1	-	OFF	-	6-5 3-2	-
	1825289-6	MHS223G04	DPDT	2.00	GOLD	5-4 2-1	-	OFF	-	6-5 3-2	-
	1825289-5	MHS22304	DPDT	2.00	SILVER	5-4 2-1	-	OFF	-	6-5 3-2	-
OBSELETE	1825289-4	MHS222KG04	DPDT	4.00	GOLD	5-4 2-1	-	NONE	-	6-5 3-2	-
	1825289-3	MHS222K04	DPDT	4.00	SILVER	5-4 2-1	-	NONE	-	6-5 3-2	-
	1825289-2	MHS222G04	DPDT	4.00	GOLD	5-4 2-1	-	NONE	-	6-5 3-2	-
	1825289-1	MHS22204	DPDT	4.00	SILVER	5-4 2-1	-	NONE	-	6-5 3-2	-
PART NO.	T&B PART NO.	TYPE	TRAVEL	PLATING	TE	TE	TE	TE	TE	TE	TE
					1 2 3 4 5 6	1 234 5 678	1 2 3 4 5 6	1 234 5 678	1 2 3 4 5 6	1 234 5 678	1 2 3 4 5 6

TERMINALS CONNECTED WHEN SLIDE IS IN POSITION SHOWN.

THIS DRAWING IS A CONTROLLED DOCUMENT. DIMENSIONS: mm. TOLERANCES UNLESS OTHERWISE SPECIFIED: 0 PLC ± .1, 1 PLC ± .1, 2 PLC ± .1, 3 PLC ± .1, 4 PLC ± .1, ANGLES ± 1°.

APPROVED: M. SARVER, 21DEC05. NAME: SLIDE SWITCH, MHS SERIES, DOUBLE POLE, VERTICAL.

SIZE: A1, CAGE CODE: 00779, DRAWING NO: 1825289, RESTRICTED TO: CUSTOMER DRAWING, SCALE: 4:1, SHEET: 1 OF 2, REV: B4.

REVISIONS				
P	LTR	DESCRIPTION	DATE	APPD
-	-	SEE SHEET 1	-	-

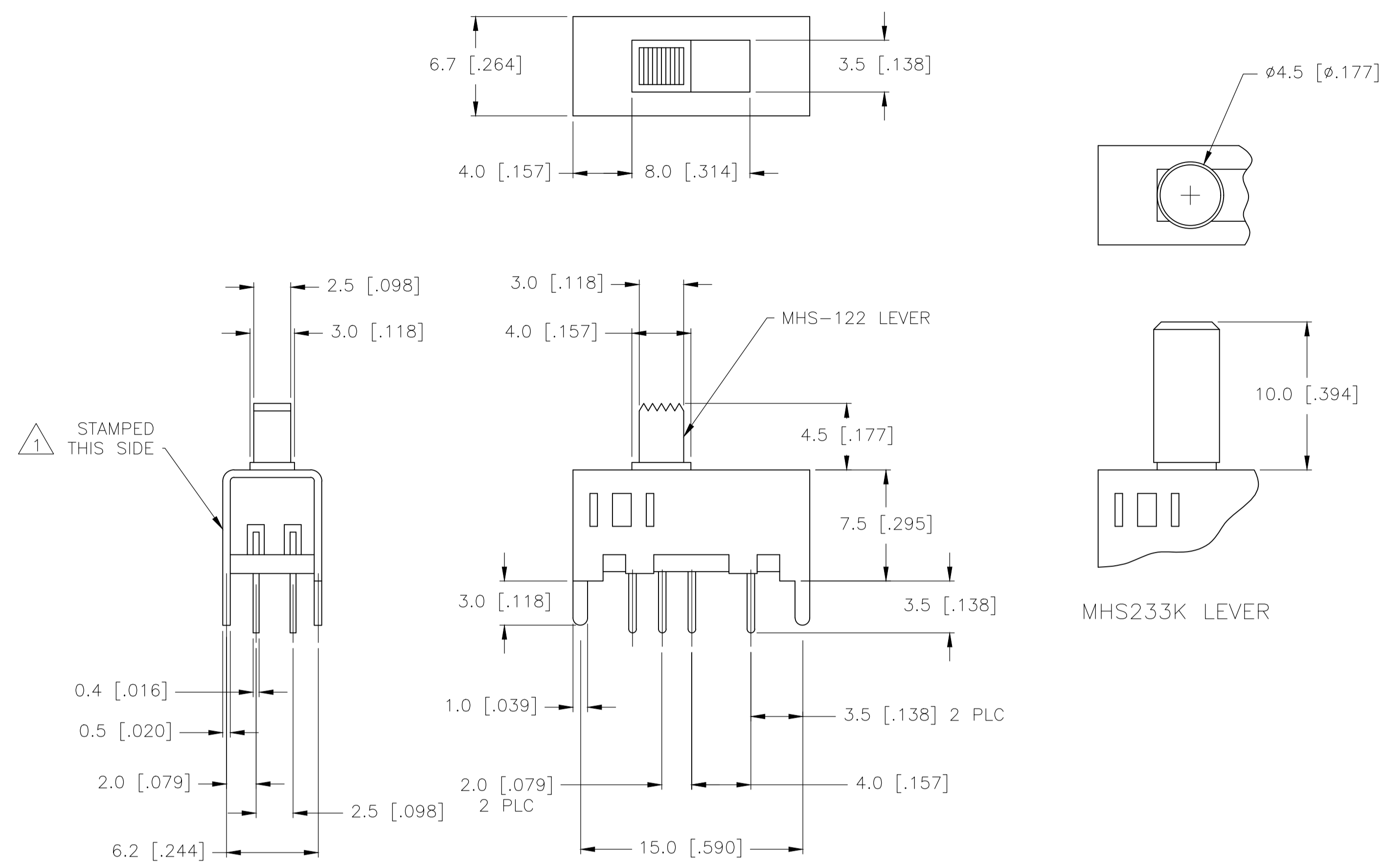

SPECIFICATIONS
BREAK-BEFORE-MAKE

MATERIALS:
 ACTUATOR- THERMOPLASTIC, UL94HB
 TERMINAL BOARD- PHENOLIC LAMINATED SHEET, UL94HB, NATURAL
 FRAME- STEEL, NICKEL PLATE
 TERMINAL/FIXED CONTACT- COPPER ALLOY, GOLD OR SILVER OVER NICKEL PLATE
 MOVING CONTACT- COPPER ALLOY, GOLD OR SILVER OVER NICKEL PLATE
 DETENT BALL- STEEL
 COIL SPRING- GALVANIZED SPRING WIRE
 LEVER,(K SERIES ONLY)- ALUMINUM
 SEAL- EPOXY

ELECTRICAL:
 CONTACT RATING- .4VA@20VDC OR PEAK AC (GOLD); 300mA@125V AC (SILVER)
 INITIAL CONTACT RESISTANCE- 30 milliohm max.
 FINAL CONTACT RESISTANCE- 100 milliohm max. (AFTER TEST)
 INSULATION RESISTANCE- 1,000 Megohms min.
 DIELECTRIC STRENGTH- 500V RMS@SEA LEVEL
 LIFE EXPECTANCY- 15,000 CYCLES MIN.

MECHANICAL:
 ACTUATION FORCE- 600+/-300 GRAMS
 TRAVEL- SEE P/N TABLE

ENVIRONMENTAL:
 OPERATING TEMPERATURE- -20 TO +85 DEGREES C
 STORAGE TEMPERATURE- -40 TO +100 DEGREES C
 RESISTANCE TO SOLDER HEAT PER 109-202, CONDITION B
 SOLDERABILITY PER EIA-364-52, CLASS 2, CATEGORY 1, 95% MIN COVERAGE

- NOTES:**
1. COUNTRY OF ORIGIN AND TE CONNECTIVITY LOGO PER TEC-202-36 LOCATED APPROXIMATELY AS SHOWN
 2. ALL MATERIALS AND FINISHES SHALL COMPLY WITH EU DIRECTIVE 2002/95/EC OF 27JAN2003 (ROHS)
 3. ANTI SOLDER WICK SEAL AT TERMINAL TO BOARD INTERFACE
 4. ALL PERFORMANCE TESTING WAS DONE IN ACCORDANCE TO TE CONNECTIVITY SPECIFICATION **102-2469**

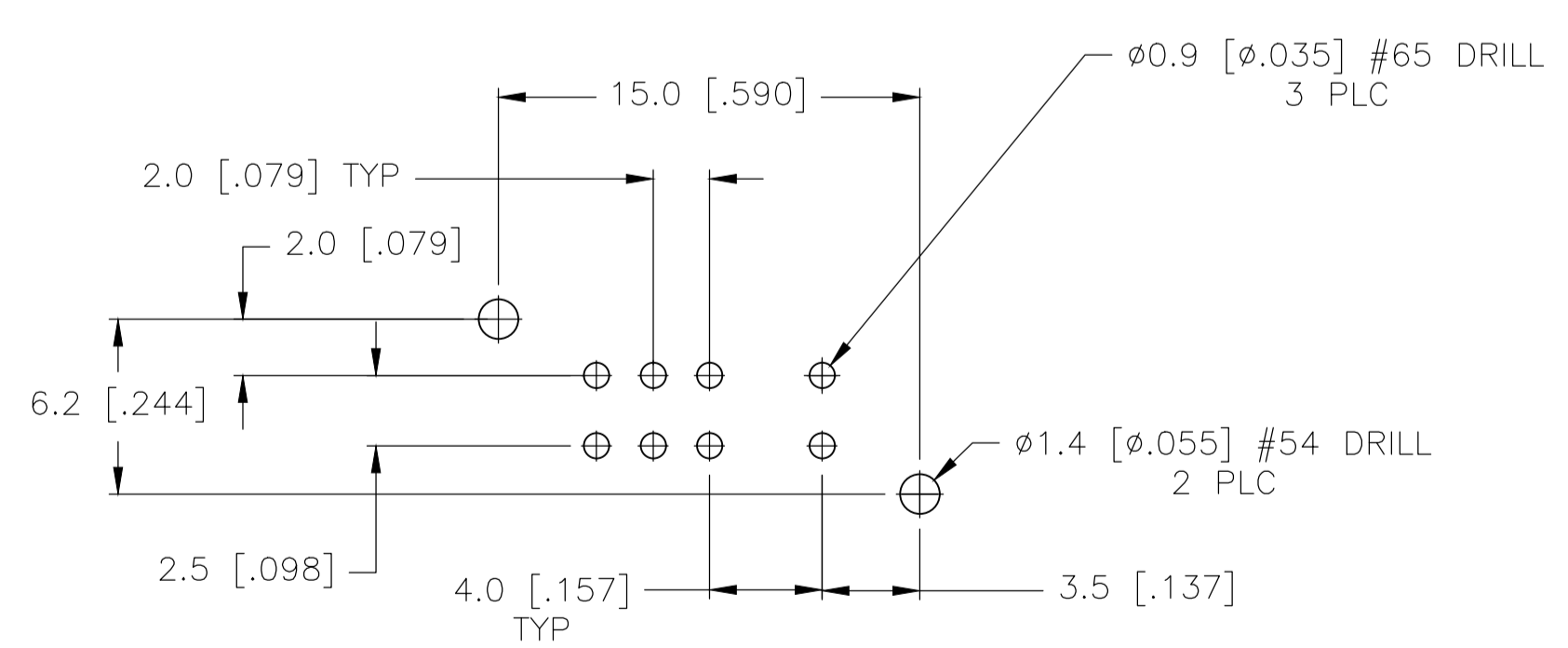
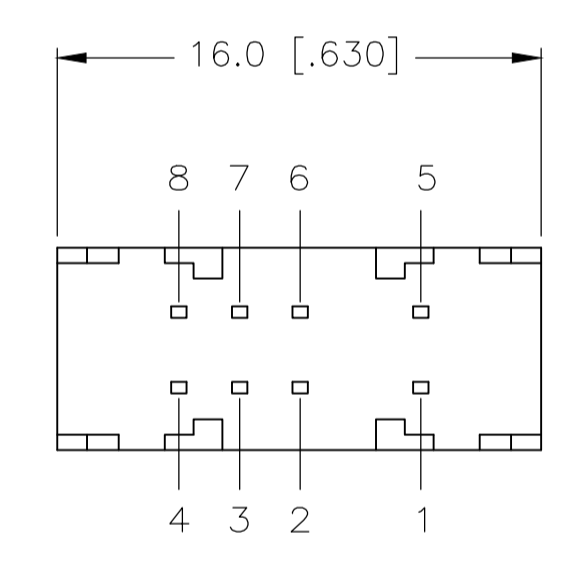

MHS233 SERIES SWITCH

THIS DRAWING IS A CONTROLLED DOCUMENT.		DIN R BROWN 21DEC05	TE Connectivity	
DIMENSIONS: mm		CHK M SARVER 21DEC05		
TOLERANCES UNLESS OTHERWISE SPECIFIED:		APPD M SARVER 21DEC05	NAME	
0 PLC	\pm -	PRODUCT SPEC	SLIDE SWITCH, MHS SERIES, DOUBLE POLE, VERTICAL	
1 PLC	\pm 0.3 [.012]	APPLICATION SPEC	SIZE CAGE CODE DRAWING NO	
2 PLC	\pm -	WEIGHT	RESTRICTED TO	
3 PLC	\pm -	A1 00779 C=1825289	SCALE 4:1 SHEET 2 OF 2 REV B4	
4 PLC	\pm -	CUSTOMER DRAWING		
ANGLES	\pm 1°			