

NOTES:

1. MATERIALS AND FINISHES:
 BNC STR BHD JACK IP 67 - BRASS, NICKEL PLATING
 MCX RA PLUG - BeCu, GOLD PLATING
 CABLE - RG 316
2. ELECTRICAL:
 A. IMPEDANCE: 50 OHM
3. PACKAGING:
 A. QUANTITY: SINGLE PACK
 B. MARKING: BAG TO BE MARKED
 "AMPHENOL RF, 95-850-303-XXX AND DATE CODE"

| REVISIONS | | | | |
|-----------|-----------------|-----------|-------|----|
| REV | DESCRIPTION | DATE | ECN | BY |
| A | RELEASE TO MFG. | 02-SEP-22 | 16383 | TR |

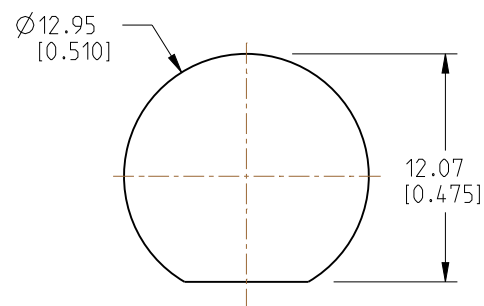

RECOMMENDED MOUNTING HOLE DIMENSIONS

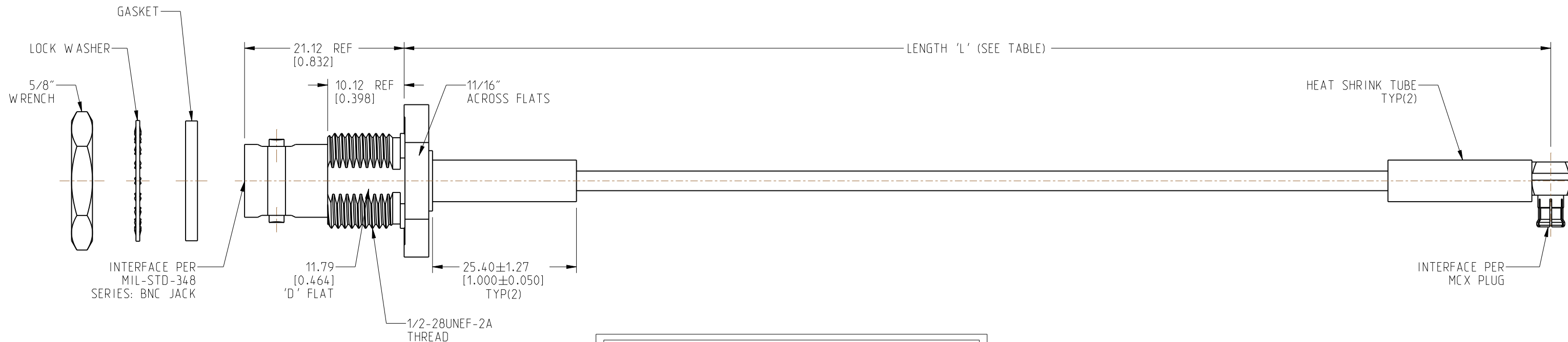
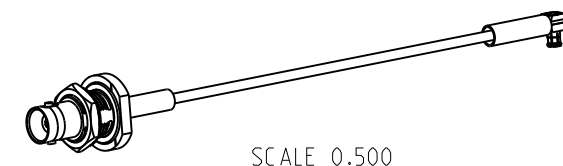

| LENGTH TABLE | | |
|------------------------|----------------------|-------------------------------|
| PART NUMBER (IMPERIAL) | PART NUMBER (METRIC) | LENGTH 'L' IN INCHES [METERS] |
| 95-850-303-006 | - | 6.00 [0.152] |
| - | 95-850-303M025 | 9.84 [0.250] |
| 95-850-303-012 | - | 12.00 [0.305] |
| 95-850-303-018 | - | 18.00 [0.457] |
| - | 95-850-303M050 | 19.69 [0.500] |
| 95-850-303-024 | - | 24.00 [0.610] |
| - | 95-850-303M075 | 29.53 [0.750] |
| 95-850-303-036 | - | 36.00 [0.914] |
| - | 95-850-303M100 | 39.37 [1.000] |
| 95-850-303-048 | - | 48.00 [1.219] |
| - | 95-850-303M200 | 78.74 [2.000] |
| - | 95-850-303M300 | 118.11 [3.000] |

| TOLERANCE TABLE | |
|---------------------------------|----------------|
| LENGTH IN INCHES/FT [METERS] | TOLERANCE |
| 0" - 23.90" [0 - 0.607] | ±0.25" [0.006] |
| 24.00" - 59.00" [0.610 - 1.499] | ±0.50" [0.013] |
| 5.0' - 24.9' [1.524 - 7.617] | ±2.5% |
| 25.0' & UP [7.620 & UP] | ±5.0% |

DESIGN REQUIREMENTS:

- | | |
|---|--|
| <input checked="" type="checkbox"/> FREQUENCY: DC - 6 GHz | <input checked="" type="checkbox"/> CONTINUITY |
| <input type="checkbox"/> VSWR: _____ 1 MAX. | <input checked="" type="checkbox"/> HI-POT: 750 VRMS |
| <input type="checkbox"/> INS. LOSS: _____ dB MAX. | <input type="checkbox"/> OTHER |

CUSTOMER OUTLINE DRAWING

ALL OTHER SHEETS ARE FOR INTERNAL USE ONLY

| | | | | | | | | | |
|--|-----------|---|--------------|-----------------------|-------------------|--|----------------|--|----------------|
| NOTICE: These drawings, specifications, or other data (1) are, and remain the property of Amphenol corp. (2) must be returned upon request; and (3) are confidential and not to be disclosed to any person other than those to whom they are given by Amphenol Corp. The furnishing of these drawings, specifications, or other data by Amphenol Corp., or to any other person to anyone for any purpose is not to be regarded by implication or otherwise in any manner licensing, granting rights to permitting such holder or any other person to manufacture, use or sell any product, process or design, patented or otherwise, that may in any way be related to or disclosed by said drawings, specifications, or other data. | | UNLESS OTHERWISE SPECIFIED DIMENSIONS ARE METRIC [INCHES] AND TOLERANCES ARE: <0.5mm = ±0.05mm [-0.020 = ±0.002] 0.5 - 6mm = ±0.1mm [-0.020 - 0.236 = ±0.004] >6.00 - 30mm = ±0.2mm [-0.236 - 1.181 = ±0.008] >30.00 - 120mm = ±0.3mm [-1.181 - 4.725 = ±0.012] | | MATERIAL SEE NOTES | | TITLE BNC STR BHD JACK IP 67 TO MCX RA PLUG USING RG 316 CABLE VARIOUS LENGTH | | Amphenol RF DRAWING NO. 95-850-303-XXX ITEM NO. 95-850-303-XXX PART NO. 95-850-303-XXX | |
| THIRD ANGLE PROJ. | REFERENCE | EAR# 11452 | ANGLES = ±1° | | ENGR.1 THAMBI RAJ | ENGR.2 | DATE 12-AUG-22 | SHEET NO. 2 OF 2 | SCALE: 2.0:1.0 |