

**CLOCK SLICER USER CONFIGURABLE PECL INPUT ZERO DELAY BUFFER ICS527-02**
**Description**

The ICS527-02 Clock Slicer is the most flexible way to generate a CMOS output clock from a PECL input clock with zero skew. The user can easily configure the device to produce nearly any output clock that is multiplied or divided from the input clock. The part supports non-integer multiplications and divisions. A SYNC pulse indicates when the rising clock edges are aligned with zero skew. Using Phase-Locked Loop (PLL) techniques, the device accepts an input clock up to 200 MHz and produces an output clock up to 160 MHz.

The ICS527-02 aligns rising edges on PECLIN with FBIN at a ratio determined by the reference and feedback dividers.

For a PECL input and output clock with zero delay, use the ICS527-04.

For a CMOS input and PECL output with zero delay, use the ICS527-03.

**Features**

- Packaged as 28-pin SSOP (150 mil body)
- Synchronizes fractional clocks rising edges
- PECL IN to CMOS OUT
- Pin selectable dividers
- Zero input to output skew
- User determines the output frequency—no software needed
- Slices frequency or period
- Input clock frequency of 1.5 MHz to 200 MHz
- Output clock frequencies from 4 MHz to 160 MHz
- Very low jitter
- Duty cycle of 45/55
- Operating voltage of 3.3 V
- Advanced, low-power CMOS process
- Industrial temperature version available

**NOTE: EOL for non-green parts to occur on 5/13/10 per PDN U-09-01**

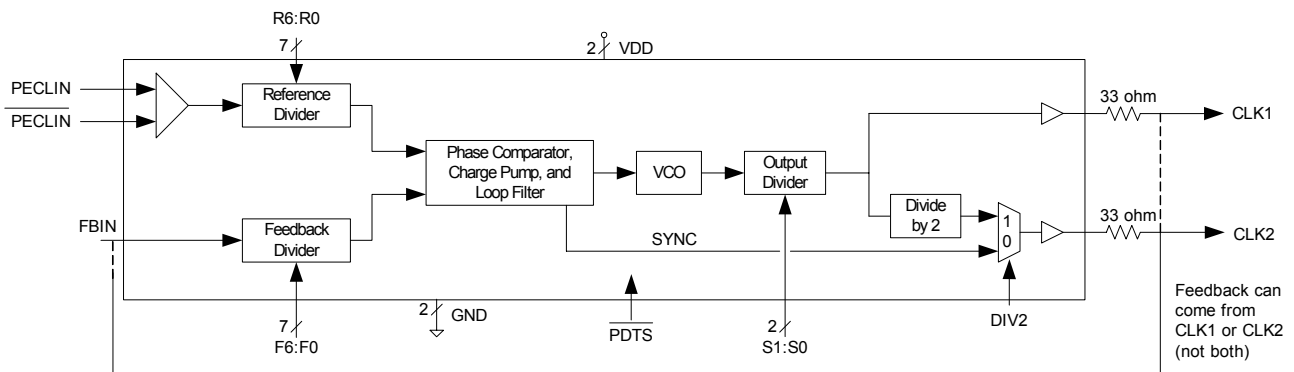
**Block Diagram**

## Pin Assignment

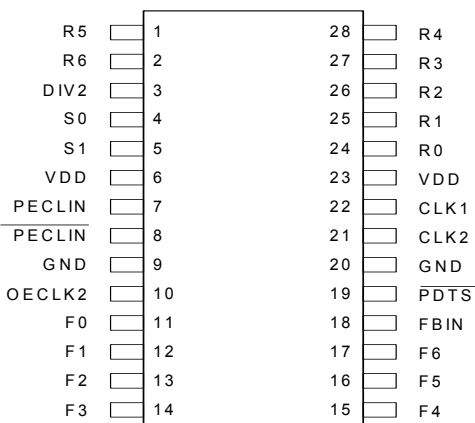

28-pin 150 mil body SSOP

## Output Frequency Range Table

S1	S0	Output Frequency (MHz)	
		Commercial	Industrial
0	0	10 - 50	16 - 45
0	1	5 - 40	8 - 33
1	0	4 - 10	4 - 8
1	1	20 - 160	32 - 140

## CLK2 Operation Table

OECLK2	DIV2	CLK2
0	X	Z
1	0	SYNC
1	1	CLK1/2

## Pin Descriptions

Pin Number	Pin Name	Pin Type	Pin Description
1,2, 24-28	R5, R6, R0-R4	Input	Reference divider word input pins determined by user. Forms a binary number from 0 to 127. Internal pull-up.
3	DIV2	Input	Selects CLK2 function to output a SYNC signal or a divide by 2 of CLK1 based on the table above. Internal pull-up.
4, 5	S0, S1	Input	Select pins for output divider determined by user. See table above. Internal pull-up.
6, 23	VDD	Power	Connect to +3.3 V.
7	PECLIN	Input	True PECL input clock.
8	$\overline{\text{PECLIN}}$	Input	Complementary PECL input clock.
9, 20	GND	Power	Connect to ground
10	OECLK2	Input	CLK2 Output Enable. CLK2 tri-stated when low. Internal pull-up.
11-17	F0-F6	Input	Feedback divider word input pins determined by user. Forms a binary number from 0 to 127. Internal pull-up
18	FBIN	Input	Feedback clock input
19	$\overline{\text{PDTS}}$	Input	Power Down. Active low. Turns off entire chip when low, both clock outputs are tri-stated. Internal pull-up.
21	CLK2	Output	Output clock 2. Can be SYNC pulse or a low skew divide by 2 of CLK1.
22	CLK1	Output	Output clock 1.

## External Components

### Decoupling Capacitors

As with any high performance mixed-signal IC, the ICS527-02 must be isolated from system power supply noise to perform optimally.

Decoupling capacitors of  $0.01\mu\text{F}$  must be connected between each VDD and the PCB ground plane. The capacitor must be connected close to the device to minimize lead inductance.

### Series Termination Resistor

Clock output traces over one inch should use series termination. To series terminate a  $50\Omega$  trace (a commonly used trace impedance), place a  $33\Omega$  resistor in series with the clock line, as close to the clock output pin as possible. The nominal impedance of the clock output is  $20\Omega$ .

### Using the ICS527-02 Clock Slicer

First use DIV2 to select the function of the CLK2 output. If DIV2 is high, a divide by 2, low skew version of CLK1 is present on CLK2. If DIV2 is low, a SYNC pulse is generated on CLK2. The SYNC pulse goes high synchronously with the rising edges of PECLIN and CLK1 that are de-skewed. The SYNC function operates at CLK1 frequencies up to 66 MHz. If neither CLK1/2 or a SYNC pulse are required, then CLK2 should be disabled by connecting OECLK2 to ground. This will also give the lowest jitter on CLK1.

Next, the feedback scheme should be chosen. If CLK2 is being used as a SYNC pulse, or is tri-stated, then CLK1 must be connected to FBIN. If CLK2 is selected to be CLK1/2 (DIV2=1, OECLK2=1) then either CLK1 or CLK2 must be connected to FBIN. The choice between CLK1 or CLK2 is illustrated by the following examples where the device has been configured to generate CLK1 that is twice the frequency on PECLIN.

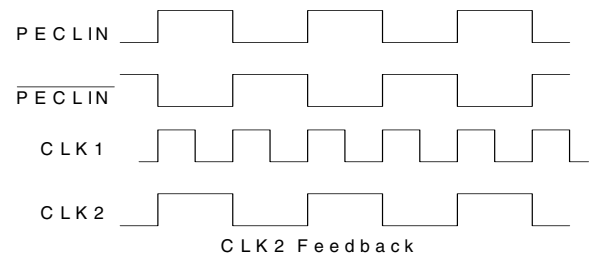
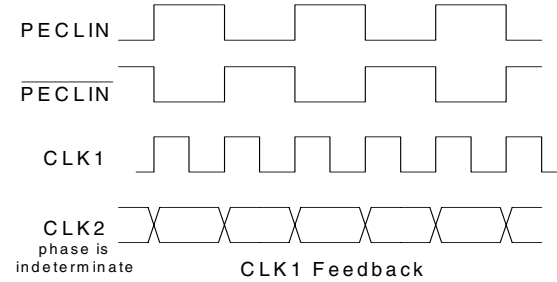

Using CLK1 as feedback will always result in synchronized rising edges between PECLIN and CLK1 if CLK1 is used as feedback. CLK2 could be a falling edge compared to PECLIN. Therefore, wherever possible it is recommended to use CLK2 for feedback, which will synchronize the rising edges of all three clocks.

More complicated feedback schemes can be used, such as incorporating multiple output buffers in the feedback path. An example is given later in the datasheet. The fundamental property of the ICS527-02 is that it aligns rising edges on PECLIN and FBIN at a ratio determined by the reference and feedback dividers.

Set S1 and S0 (page 2) based on the output frequency.

Lastly, the divider settings should be selected. This is described in the following section.

### Determining ICS527-02 Divider Settings

The user has full control in setting the desired output clock over the range shown in the table on page 2. The user should connect the divider select input pins directly to ground (or VDD, although this is not required

because of internal pull-ups) during Printed Circuit Board layout, so the ICS527-02 automatically produces the correct clock when mounted on the board. It is also possible to connect the inputs to parallel I/O ports in order to switch frequencies.

The output of the ICS527-02 can be determined by the following simple equation:

$$\text{FB Frequency} = \text{Input Frequency} \times \frac{\text{FDW} + 2}{\text{RDW} + 2}$$

Where:

- Reference Divider Word (RDW) = 0 to 127
- Feedback Divider Word (FDW) = 0 to 127
- FB Frequency is the same as either CLK1 or CLK2 depending on feedback connection

Also, the following operating ranges should be observed:

$$300\text{kHz} < \frac{\text{Input Frequency}}{\text{RDW} + 2} < 20 \text{ MHz}$$

### Typical Example

The layout diagram below will produce the waveforms shown on the right.

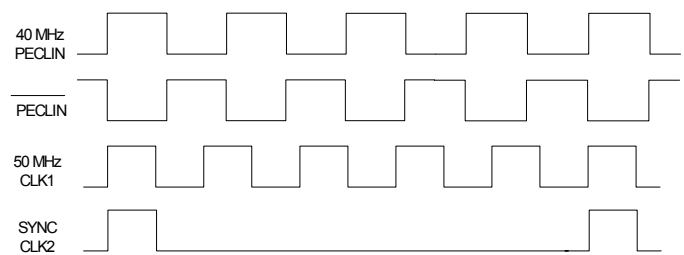
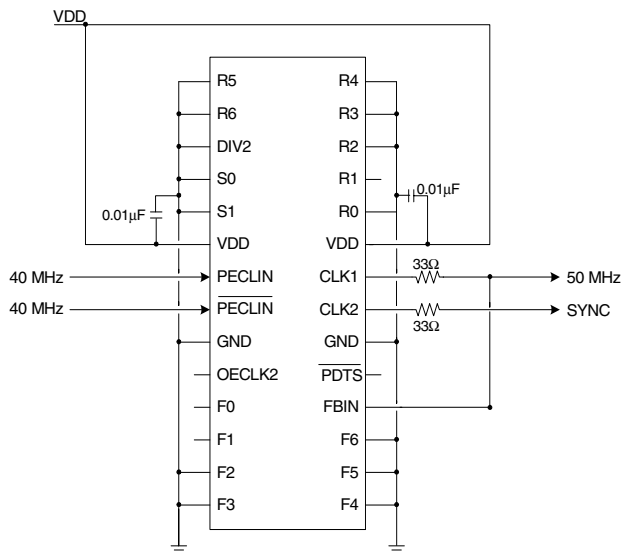

S0 and S1 should be selected depending on the frequency of CLK1. The table on page 2 gives the ranges.

The dividers are expressed as integers. For example, if a 50 MHz output on CLK1 is desired from a 40 MHz input, the reference divider word (RDW) should be 2 and the feedback divider word (FDW) should be 3 which gives the required 5/4 multiplication. If multiple choices of dividers are available, then the lowest numbers should be used. In this example, the output divide (OD) should be selected to be 2. Then R6:R0 is 000010, F6:F0 is 000011 and S1:S0 is 00. Also, this example assumes CLK1 is connected to FBIN.

If you need assistance determining the optimum divider settings, please send an e-mail to [mk-support@icst.com](mailto:mk-support@icst.com) with the desired input clock and the desired output frequency.

Note: The series termination resistor is located before the feedback trace.

## Multiple Output Example

In this example, an input clock of 125 MHz is used. Eight copies of 50 MHz are required as are eight copies of 25 MHz, de-skewed and aligned to the 125 MHz input clock. The following solution uses the MK74CB217 which has dual 1 to 8 buffers with low pin-to-pin skew.

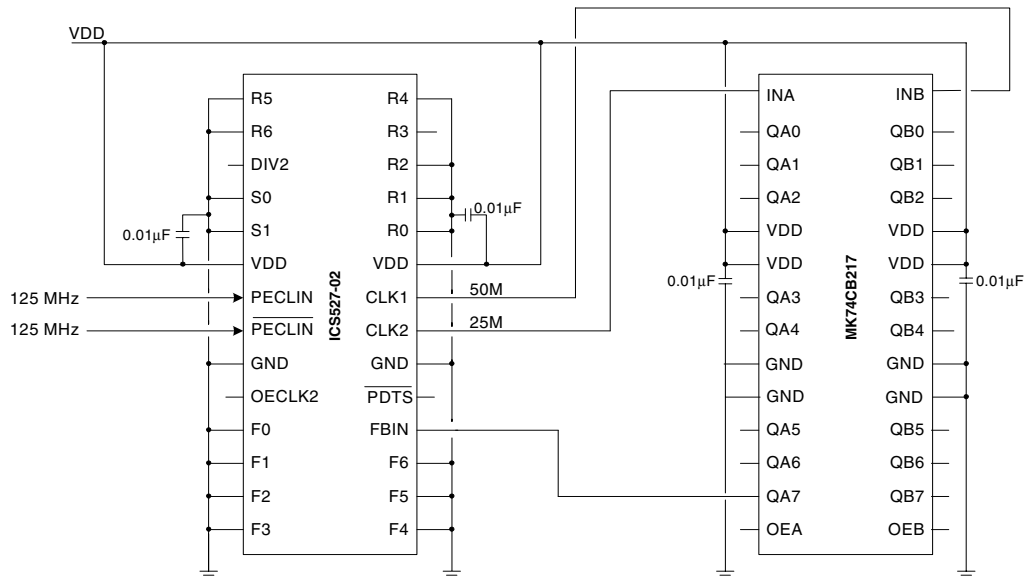

The layout design above produces the waveforms shown below. Note: Series terminating resistors are not shown.

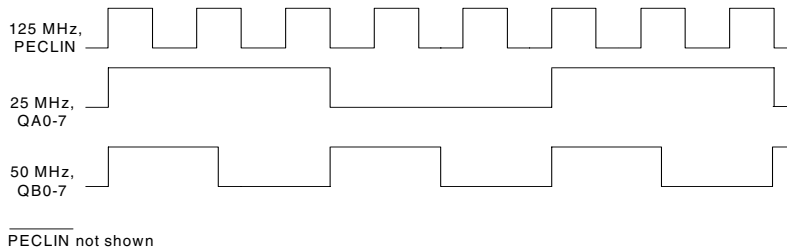

## PCB Layout Recommendations

For optimum device performance and lowest output phase noise, the following guidelines should be observed.

1) Each 0.01µF decoupling capacitor should be mounted on the component side of the board as close to the VDD pin as possible. No via's should be used between decoupling capacitor and VDD pin. The PCB trace to VDD pin should be kept as short as possible, as should the PCB trace to the ground via.

2) To minimize EMI the 33Ω series termination resistor, if needed, should be placed close to the clock outputs.

3) An optimum layout is one with all components on the same side of the board, minimizing vias through other signal layers. Other signal traces should be routed away from the ICS527-02. This includes signal traces just underneath the device, or on layers adjacent to the ground plane layer used by the device.

## Absolute Maximum Ratings

Stresses above the ratings listed below can cause permanent damage to the ICS527-02. These ratings, which are standard values for IDT commercially rated parts, are stress ratings only. Functional operation of the device at these or any other conditions above those indicated in the operational sections of the specifications is not implied. Exposure to absolute maximum rating conditions for extended periods can affect product reliability. Electrical parameters are guaranteed only over the recommended operating temperature range.

Item	Rating
Supply Voltage, VDD	7 V
All Inputs and Outputs	-0.5 V to VDD+0.5 V
Ambient Operating Temperature	-40 to +85° C
Storage Temperature	-65 to +150° C
Junction Temperature	125° C
Soldering Temperature	260° C

## Recommended Operation Conditions

Parameter	Min.	Typ.	Max.	Units
Ambient Operating Temperature, ICS527R-02	0	–	+70	° C
Ambient Operating Temperature, ICS527R-02I	-40	–	+85	° C
Power Supply Voltage (measured in respect to GND)	+3.135	+3.3	+3.465	V

## DC Electrical Characteristics

Unless stated otherwise, VDD = 3.3V ±5%, Ambient Temperature 0 to +70° C

Parameter	Symbol	Conditions	Min.	Typ.	Max.	Units
Operating Voltage	VDD		3.135	3.3	3.465	V
Supply Current	IDD	15 MHz in, 60 MHz out, no load		18		mA
Supply Current, Power Down	IDDPD	$\overline{PDT\overline{S}}=0$		20		μA
Input High Voltage	V <sub>IH</sub>		2			V
Input Low Voltage	V <sub>IL</sub>				0.8	V
Input Voltage, peak-to-peak		PECLIN, $\overline{PECLIN}$	0.3		1	V
Common Mode Range		PECLIN, $\overline{PECLIN}$	VDD-1.4		VDD-0.6	V
Output High Voltage	V <sub>OH</sub>	I <sub>OH</sub> = -12 mA	2.4			V
Output Low Voltage	V <sub>OL</sub>	I <sub>OL</sub> = 12 mA			0.4	V

Parameter	Symbol	Conditions	Min.	Typ.	Max.	Units
Input Capacitance	$C_{IN}$	Except PECLIN and FBIN		5		pF
Short Circuit Current	$I_{OS}$			$\pm 70$		mA
On-chip pull-up resistor	$R_{PU}$			270		k $\Omega$

## AC Electrical Characteristics

Unless stated otherwise, VDD = 3.3 V  $\pm 5\%$ , Ambient Temperature -40 to +85° C

Parameter	Symbol	Conditions	Min.	Typ.	Max.	Units
Input Frequency	$F_{IN}$		1.5		200	MHz
Output Frequency, CLK1	$F_{OUT}$	0 to +70° C	4		160	MHz
		-40 to +85° C	4		140	MHz
Output Rise Time	$t_{OR}$	0.8 to 2.0 V, $C_L=15$ pF		1		ns
Output Fall Time	$t_{OF}$	2.0 to 0.8 V, $C_L=15$ pF		1		ns
Output Duty Cycle (% high time)	$t_{OD}$	Measured at VDD/2, $C_L=15$ pF	45	50	55	%
Power Down Time, $\overline{PDT\overline{S}}$ low to clocks tri-stated					50	ns
Power Up Time, $\overline{PDT\overline{S}}$ high to clocks stable					10	ms
Absolute Clock Period Jitter	$t_{ja}$	Deviation from mean		$\pm 90$		ps
One sigma Clock Period Jitter	$t_{js}$			40		ps
Input to output skew	$t_{IO}$	PECLIN to CLK1, Note 1	-250		250	ps
Device to device skew	$t_{pi}$	Common PECLIN, measured at FBIN		0	500	ps

Note 1: Assumes clocks with same rise time, measured from rising edges at VDD/2.

### Package Outline and Package Dimensions (28-pin SSOP, .150 mil Body, 0.025 mm Pitch)

Package dimensions are kept current with JEDEC Publication No. 95, MO-153

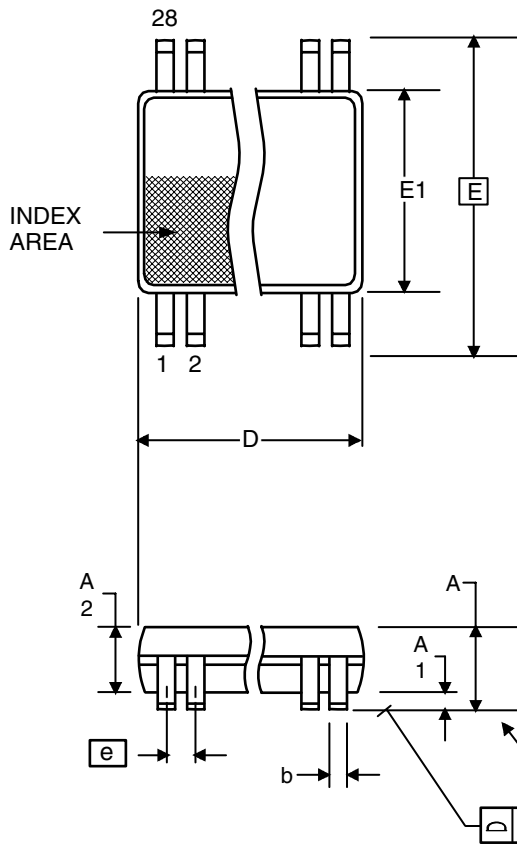

Symbol	Millimeters		Inches	
	Min	Max	Min	Max
A	1.35	1.75	.053	.069
A1	0.10	0.25	.0040	.010
A2	--	1.50	--	.059
b	0.20	0.30	.008	.012
C	0.18	0.25	.007	.010
D	9.80	10.00	.386	.394
E	5.80	6.20	.228	.244
E1	3.80	4.00	.150	.157
e	0.635 Basic		0.025 Basic	
L	0.40	1.27	.016	.050
α	0°	8°	0°	8°
aaa	--	0.10	--	0.004

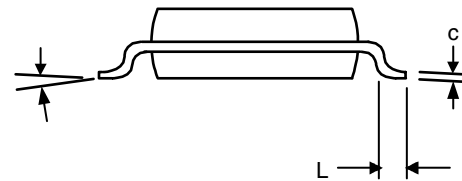



## Ordering Information

Part / Order Number	Marking	Shipping Packaging	Package	Temperature
527R-02*	ICS527R-02	Tubes	28-pin SSOP	0 to +70° C
527R-02T*	ICS527R-02	Tape and Reel	28-pin SSOP	0 to +70° C
527R-02I*	ICS527R-02I	Tubes	28-pin SSOP	-40 to +85° C
527R-02IT*	ICS527R-02I	Tape and Reel	28-pin SSOP	-40 to +85° C
527R-02LF	527R02LF	Tubes	28-pin SSOP	0 to +70° C
527R-02LFT	527R02LF	Tape and Reel	28-pin SSOP	0 to +70° C
527R-02ILF	527R02ILF	Tubes	28-pin SSOP	-40 to +85° C
527R-02ILFT	527R02ILF	Tape and Reel	28-pin SSOP	-40 to +85° C

**\*NOTE: EOL for non-green parts to occur on 5/13/10 per PDN U-09-01**

While the information presented herein has been checked for both accuracy and reliability, Integrated Device Technology (IDT) assumes no responsibility for either its use or for the infringement of any patents or other rights of third parties, which would result from its use. No other circuits, patents, or licenses are implied. This product is intended for use in normal commercial applications. Any other applications such as those requiring extended temperature range, high reliability, or other extraordinary environmental requirements are not recommended without additional processing by IDT. IDT reserves the right to change any circuitry or specifications without notice. IDT does not authorize or warrant any IDT product for use in life support devices or critical medical instruments.

**Innovate with IDT and accelerate your future networks. Contact:**

**[www.IDT.com](http://www.IDT.com)**

**For Sales**

800-345-7015  
408-284-8200  
Fax: 408-284-2775

**For Tech Support**

[www.idt.com/go/clockhelp](http://www.idt.com/go/clockhelp)

---

**Corporate Headquarters**

Integrated Device Technology, Inc.  
[www.idt.com](http://www.idt.com)



[www.IDT.com](http://www.IDT.com)