

## Low-Voltage, Low $R_{ON}$ , SPDT Audio Switch with Negative Swing Capability

### DESCRIPTION

The DG2612, DG2613 is a low on-resistance, single-pole/double-throw monolithic CMOS analog switch with negative signal swing capability. It is designed for low voltage applications. The DG2612, DG2613 is ideal for portable and battery powered equipment, requiring high performance and efficient use of board space. In addition to the low on-resistance ( $1.0 \Omega$  at 2.7 V), the DG2613 has a typical off isolation and crosstalk of -67 dB and -73 dB respectively. The DG2612, DG2613 is built on Vishay Siliconix's low voltage process.

Break-before-make is guaranteed.

As a committed partner to the community and the environment, Vishay Siliconix manufactures this product with the lead (Pb)-free device terminations. For analog switching products manufactured with 100 % matte tin device terminations, the lead (Pb)-free "-E3" suffix is being used as a designator.

### FEATURES

- Low voltage operation (1.8 V to 5.5 V)
- Low on-resistance -  $R_{ON}$ :  $1.0 \Omega$  at 2.7 V
- High bandwidth

**RoHS  
COMPLIANT**

### BENEFITS

- Negative signal swing capability
- Shunt switch to eliminate switching noise
- Simplified design with direct DC coupling
- Space saving SC-89 package

### APPLICATIONS

- Cellular phones
- Portable multimedia players
- PDAs and hand-held devices
- Laptop computers

### FUNCTIONAL BLOCK DIAGRAM AND PIN CONFIGURATION

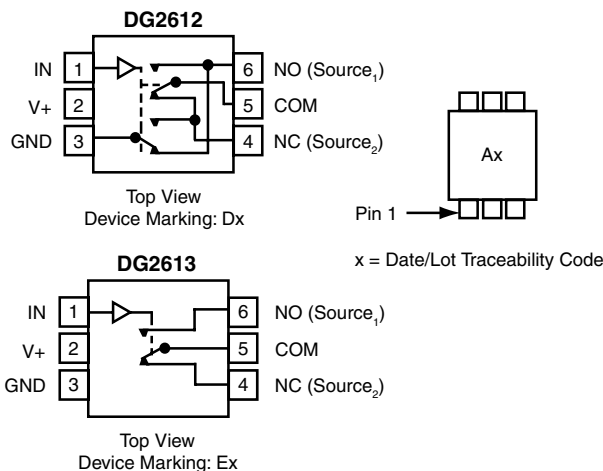

### TRUTH TABLE

Logic	NC	NO
0	ON	OFF
1	OFF	ON

### COMMERCIAL ORDERING INFORMATION

Temp Range	Package	Part Number
-40 °C to 85 °C	SC-89 (SOT-666) Lead (Pb)-free with Tape and Reel	DG2612DX-T1-E3 DG2613DX-T1-E3

### ABSOLUTE MAXIMUM RATINGS $T_A = 25 \text{ }^\circ\text{C}$ , unless otherwise noted

Parameter	Symbol	Limit	Unit
Reference GND	V+	- 0.3 to + 6	V
	IN <sup>a</sup>	- 0.3 to (V+ + 0.3)	
	COM, NC, NO <sup>a</sup>	(V+ - 6) to (V+ + 0.3)	
Continuous Current (NO, NC, COM pins)		$\pm 150$	mA
Peak Current (Pulsed at 1 ms, 10 % duty cycle)		$\pm 300$	
Storage Temperature	D Suffix	- 65 to 150	$^\circ\text{C}$
Power Dissipation (Packages) <sup>b</sup>	SC-89 <sup>c</sup>	172	mW

Notes:

- Signals on NC, NO, or COM or IN exceeding V+ will be clamped by internal diodes. Limit forward diode current to maximum current ratings.
- All leads welded or soldered to PC board.
- Derate 2.15 mW/ $^\circ\text{C}$  above 70  $^\circ\text{C}$ .

SPECIFICATIONS (V <sub>+</sub> = 3 V)							
Parameter	Symbol	Test Conditions Otherwise Unless Specified V <sub>+</sub> = 3 V, ± 10 %, V <sub>IN</sub> = 0.5 V or 1.4 V <sup>e</sup>	Temp. <sup>a</sup>	Limits - 40 °C to 85 °C			Unit
				Min. <sup>b</sup>	Typ. <sup>c</sup>	Max. <sup>b</sup>	
<b>Analog Switch</b>							
Analog Signal Range <sup>d</sup>	V <sub>NO</sub> , V <sub>NC</sub> , V <sub>COM</sub>		Full	V <sub>+</sub> - 5.5		V <sub>+</sub>	V
On-Resistance	R <sub>ON</sub>	V <sub>+</sub> = 2.7 V, V <sub>COM</sub> = - 1 V/0 V/1 V/2 V I <sub>NO</sub> , I <sub>NC</sub> = 10 mA	Room		1.0	1.4	Ω
R <sub>ON</sub> Match <sup>d</sup>	ΔR <sub>ON</sub>		Full			1.6	
R <sub>ON</sub> Flatness <sup>d</sup>	R <sub>ON</sub> Flatness		Room			0.1	
Shunt Switch Resistance	R <sub>SH</sub>	I <sub>NO</sub> or I <sub>NC</sub> = 10 mA, V <sub>+</sub> = 2.7 V, DG2612 only	Room			0.3	Ω
Switch Off Leakage Current	I <sub>NO(off)</sub>	V <sub>+</sub> = 3.3 V, V <sub>NO</sub> , V <sub>NC</sub> = 1 V/3 V, V <sub>COM</sub> = 3 V/1 V	Room	- 2		2	nA
	I <sub>NC(off)</sub>		Full	- 100		100	
	I <sub>COM(off)</sub>		Room	- 2		2	
Channel-On Leakage Current	I <sub>COM(on)</sub>	V <sub>+</sub> = 3.3 V, V <sub>NO</sub> , V <sub>NC</sub> = V <sub>COM</sub> = 1 V/3 V	Full	- 100		100	
<b>Digital Control</b>							
Input High Voltage	V <sub>INH</sub>	V <sub>+</sub> = 1.8 V to 2.0 V	Full	1.0			V
		V <sub>+</sub> = 2.7 V to 3.6 V		1.4			
		V <sub>+</sub> = 4.2 V to 5.5 V		2.0			
Input Low Voltage	V <sub>INL</sub>	V <sub>+</sub> = 1.8 V to 2.0 V				0.4	
		V <sub>+</sub> = 2.7 V to 3.6 V				0.5	
		V <sub>+</sub> = 4.2 V to 5.5 V				0.8	
Input Capacitance	C <sub>in</sub>		Full		5		pF
Input Current	I <sub>INL</sub> or I <sub>INH</sub>	V <sub>IN</sub> = 0 or V <sub>+</sub>	Full	1		1	μA
<b>Dynamic Characteristics</b>							
Turn-On Time	t <sub>ON</sub>	V <sub>NO</sub> or V <sub>NC</sub> = 1.5 V, R <sub>L</sub> = 50 Ω, C <sub>L</sub> = 35 pF	Room		34	60	ns
Turn-Off Time	t <sub>OFF</sub>		Full		10	35	
Break-Before-Make Time	t <sub>BBM</sub>		Room	4	16	37	
Charge Injection <sup>d</sup> (DG2613)	Q <sub>INJ</sub>	C <sub>L</sub> = 1 nF, V <sub>GEN</sub> = 0 V, R <sub>GEN</sub> = 0 Ω	Room		2.4		pC
Off-Isolation <sup>d</sup>	OIRR	R <sub>L</sub> = 50 Ω, C <sub>L</sub> = 5 pF, f = 100 kHz DG2612	Room		- 61		dB
Crosstalk <sup>d</sup>	X <sub>TALK</sub>		Room		- 67		
Off-Isolation <sup>d</sup>	OIRR	R <sub>L</sub> = 50 Ω, C <sub>L</sub> = 5 pF, f = 100 kHz DG2613	Room		- 67		dB
Crosstalk <sup>d</sup>	X <sub>TALK</sub>		Room		- 73		
N <sub>O</sub> , N <sub>C</sub> Off Capacitance <sup>d</sup>	C <sub>NO(off)</sub> C <sub>NC(off)</sub>	V <sub>IN</sub> = 0 or V <sub>+</sub> , f = 1 MHz	Room		36		pF
Channel-On Capacitance <sup>d</sup>	C <sub>ON</sub>		Room		95		
<b>Power Supply</b>							
Power Supply Range	V <sub>+</sub>			1.8		5.5	V
Power Supply Current	I <sub>+</sub>	V <sub>IN</sub> = 0 or V <sub>+</sub>			0.01	1.0	μA

Notes:

- Room = 25 °C, Full = as determined by the operating suffix.
- Typical values are for design aid only, not guaranteed nor subject to production testing.
- The algebraic convention whereby the most negative value is a minimum and the most positive a maximum, is used in this data sheet.
- Guarantee by design, nor subjected to production test.
- V<sub>IN</sub> = input voltage to perform proper function.

Stresses beyond those listed under "Absolute Maximum Ratings" may cause permanent damage to the device. These are stress ratings only, and functional operation of the device at these or any other conditions beyond those indicated in the operational sections of the specifications is not implied. Exposure to absolute maximum rating conditions for extended periods may affect device reliability.

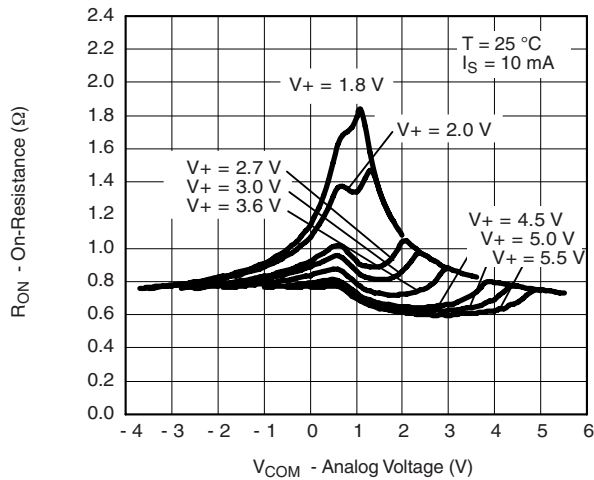
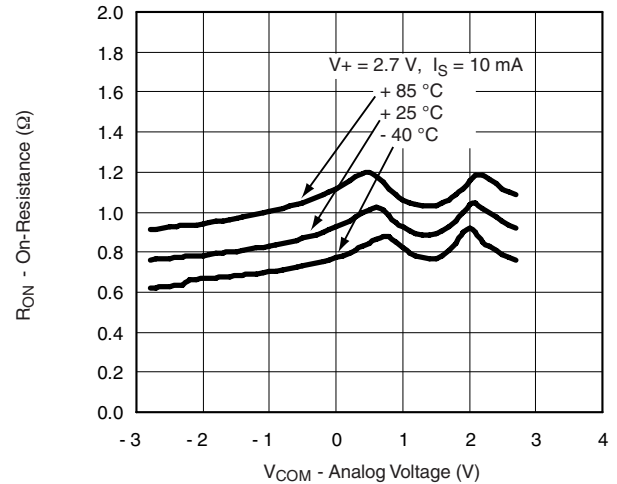
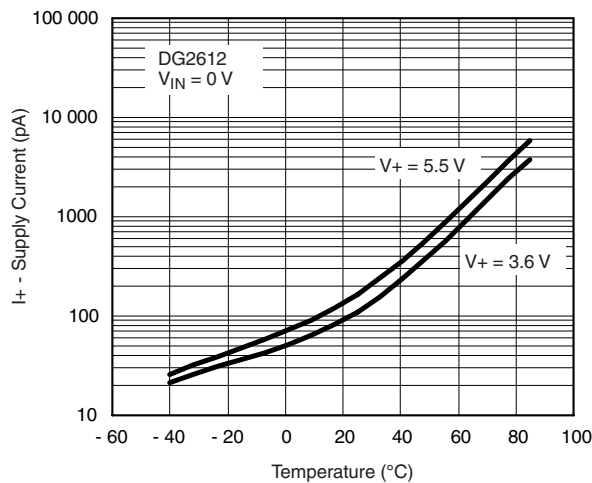
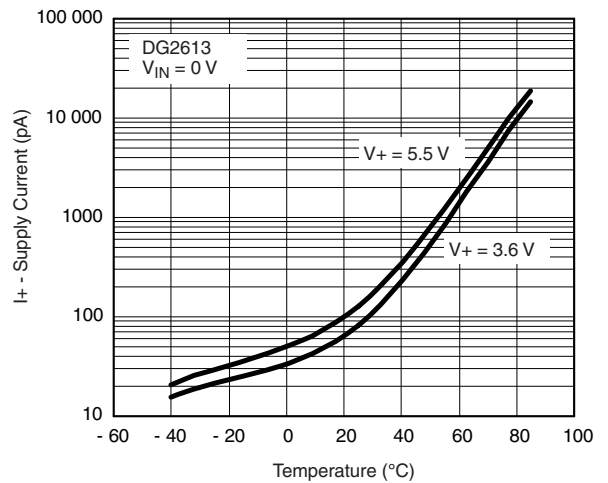
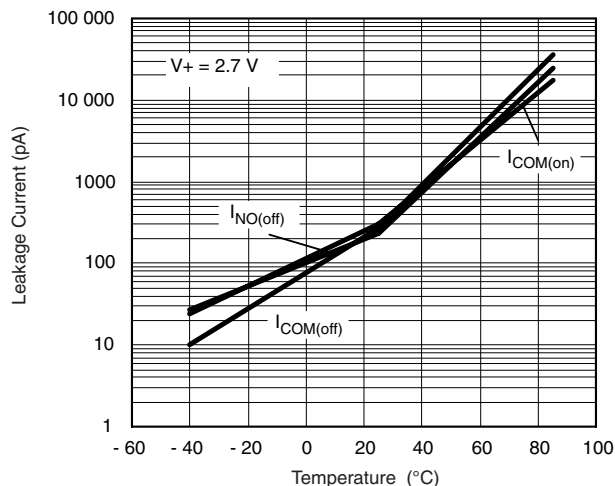
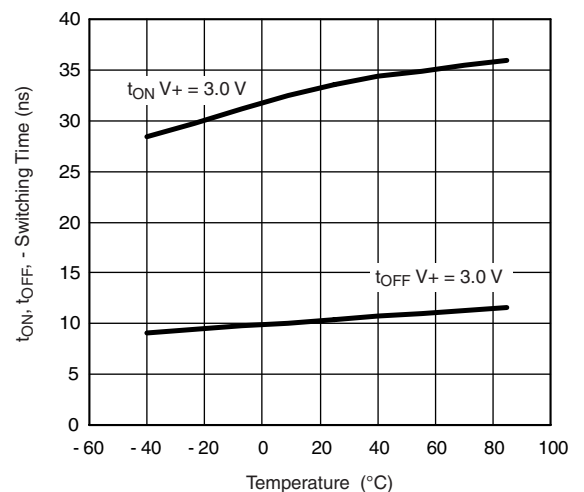
**TYPICAL CHARACTERISTICS**  $T_A = 25\text{ }^\circ\text{C}$ , unless otherwise noted

 **$R_{ON}$  vs.  $V_{COM}$  and Supply Voltage**

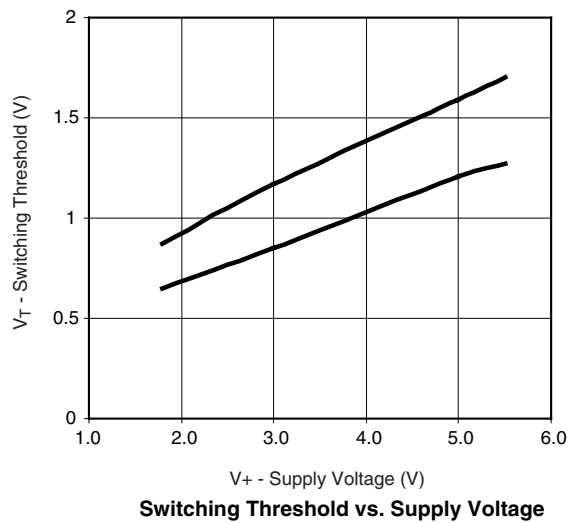
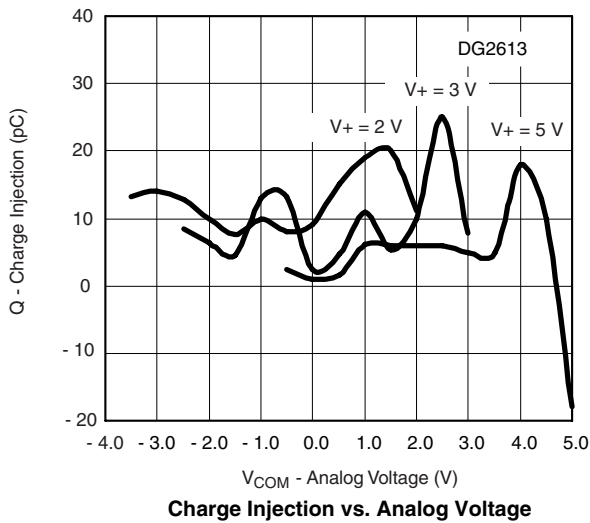
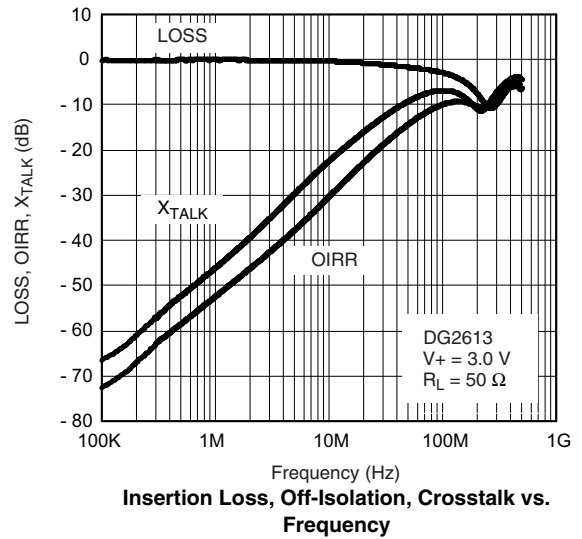
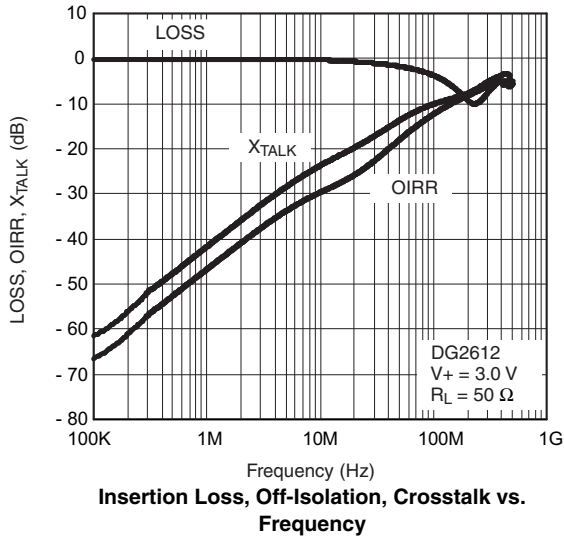
 **$R_{ON}$  vs. Analog Voltage and Temperature**

**Supply Current vs. Temperature**

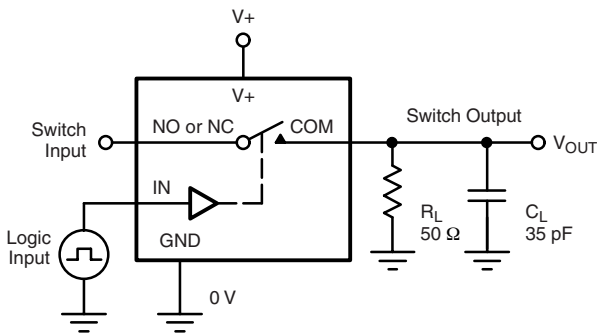
**Supply Current vs. Temperature**

**Leakage Current vs. Temperature**

**Switching Time vs. Temperature and Supply Voltage**

### TYPICAL CHARACTERISTICS $T_A = 25\text{ }^\circ\text{C}$ , unless otherwise noted



### TEST CIRCUITS



$C_L$  (includes fixture and stray capacitance)

$$V_{OUT} = V_{COM} \left( \frac{R_L}{R_L + R_{ON}} \right)$$

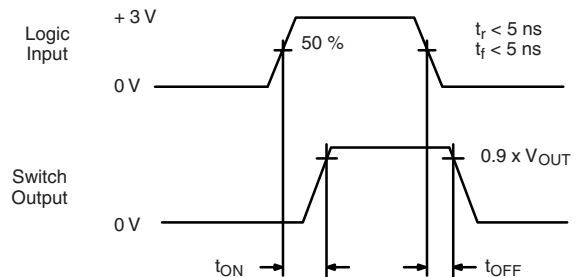

Logic "1" = Switch On  
 Logic input waveforms inverted for switches that have the opposite logic sense.

Figure 1. Switching Time

TEST CIRCUITS

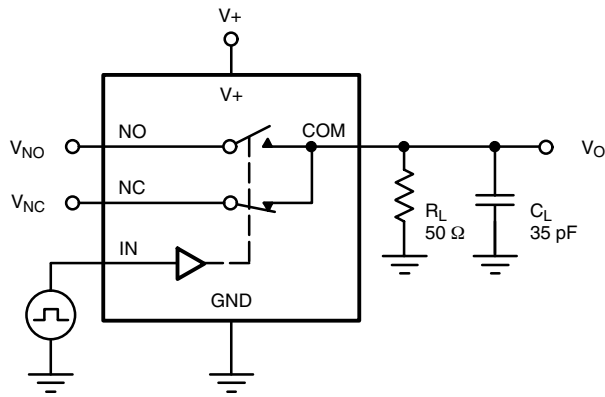

$C_L$  (includes fixture and stray capacitance)

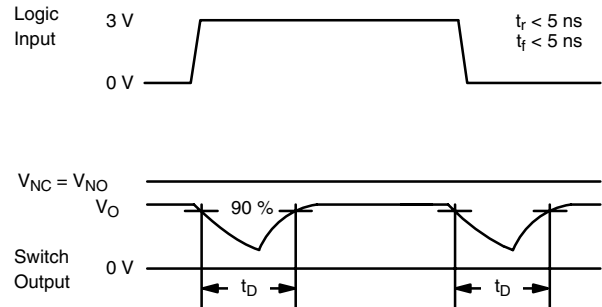
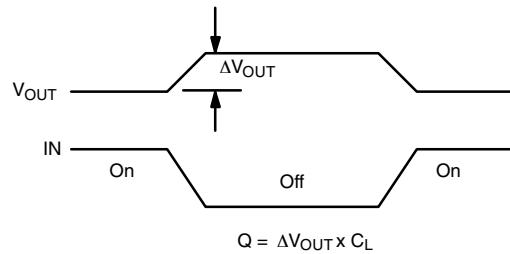
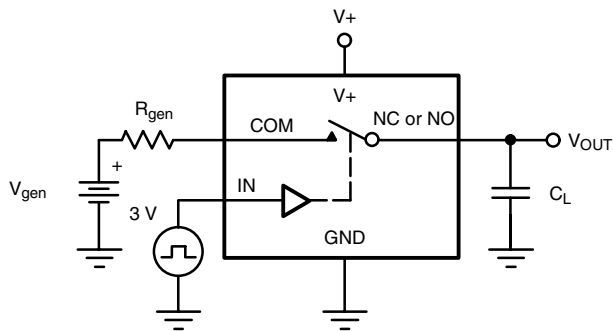

Figure 2. Break-Before-Make Interval



IN depends on switch configuration: input polarity determined by sense of switch.

Figure 3. Charge Injection

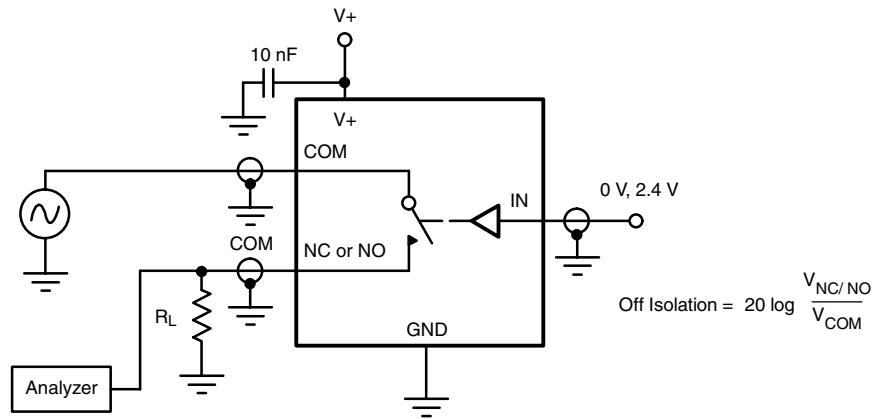

Figure 4. Off-Isolation

## TEST CIRCUITS

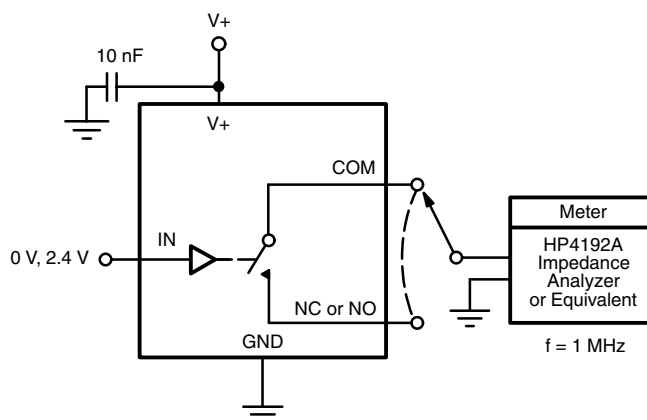
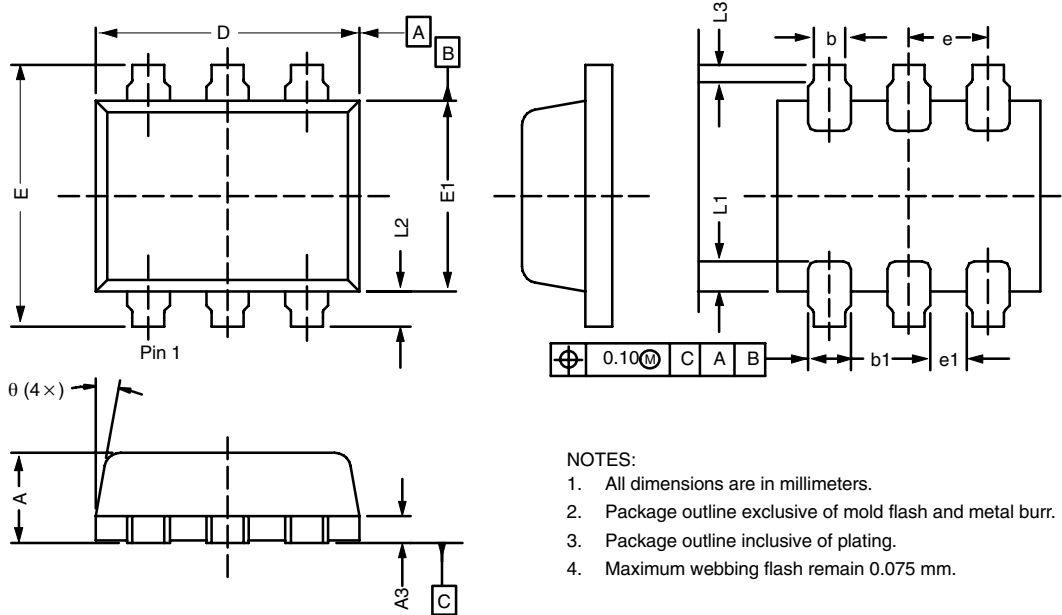

Figure 5. Channel Off/On Capacitance

Vishay Siliconix maintains worldwide manufacturing capability. Products may be manufactured at one of several qualified locations. Reliability data for Silicon Technology and Package Reliability represent a composite of all qualified locations. For related documents such as package/tape drawings, part marking, and reliability data, see [www.vishay.com/ppg?74339](http://www.vishay.com/ppg?74339).

### SC-89: 6-LEAD (SOT-666)



- NOTES:
1. All dimensions are in millimeters.
  2. Package outline exclusive of mold flash and metal burr.
  3. Package outline inclusive of plating.
  4. Maximum webbing flash remain 0.075 mm.

Dim	MILLIMETERS*			INCHES		
	Min	Nom	Max	Min	Nom	Max
<b>A</b>	0.56	–	0.60	0.022	–	0.024
<b>A3</b>	0.13	0.17	0.18	0.005	0.006	0.007
<b>b</b>	0.17	–	0.25	0.006	–	0.010
<b>b1</b>	–	0.27	0.34	–	0.011	0.013
<b>D</b>	1.50	1.66	1.70	0.059	0.065	0.067
<b>E</b>	1.50	1.65	1.70	0.059	0.065	0.067
<b>E1</b>	1.10	1.20	1.30	0.043	0.047	0.051
<b>e</b>	0.50 BSC			0.020 BSC		
<b>e1</b>	0.20	–	–	0.008	–	–
<b>L1</b>	0.11	0.19	0.26	0.004	0.007	0.010
<b>L2</b>	0.10	0.23	0.30	0.004	0.009	0.012
<b>L3</b>	0.05	0.10	–	0.002	0.004	–
<b>θ</b>	8°	10°	12°	8°	10°	12°
ECN: S-52444—Rev. D, 28-Nov-05 DWG: 5891						

\*Use millimeters as the primary measurement



## Disclaimer

ALL PRODUCT, PRODUCT SPECIFICATIONS AND DATA ARE SUBJECT TO CHANGE WITHOUT NOTICE TO IMPROVE RELIABILITY, FUNCTION OR DESIGN OR OTHERWISE.

Vishay Intertechnology, Inc., its affiliates, agents, and employees, and all persons acting on its or their behalf (collectively, "Vishay"), disclaim any and all liability for any errors, inaccuracies or incompleteness contained in any datasheet or in any other disclosure relating to any product.

Vishay makes no warranty, representation or guarantee regarding the suitability of the products for any particular purpose or the continuing production of any product. To the maximum extent permitted by applicable law, Vishay disclaims (i) any and all liability arising out of the application or use of any product, (ii) any and all liability, including without limitation special, consequential or incidental damages, and (iii) any and all implied warranties, including warranties of fitness for particular purpose, non-infringement and merchantability.

Statements regarding the suitability of products for certain types of applications are based on Vishay's knowledge of typical requirements that are often placed on Vishay products in generic applications. Such statements are not binding statements about the suitability of products for a particular application. It is the customer's responsibility to validate that a particular product with the properties described in the product specification is suitable for use in a particular application. Parameters provided in datasheets and/or specifications may vary in different applications and performance may vary over time. All operating parameters, including typical parameters, must be validated for each customer application by the customer's technical experts. Product specifications do not expand or otherwise modify Vishay's terms and conditions of purchase, including but not limited to the warranty expressed therein.

Except as expressly indicated in writing, Vishay products are not designed for use in medical, life-saving, or life-sustaining applications or for any other application in which the failure of the Vishay product could result in personal injury or death. Customers using or selling Vishay products not expressly indicated for use in such applications do so at their own risk. Please contact authorized Vishay personnel to obtain written terms and conditions regarding products designed for such applications.

No license, express or implied, by estoppel or otherwise, to any intellectual property rights is granted by this document or by any conduct of Vishay. Product names and markings noted herein may be trademarks of their respective owners.

## Material Category Policy

**Vishay Intertechnology, Inc. hereby certifies that all its products that are identified as RoHS-Compliant fulfill the definitions and restrictions defined under Directive 2011/65/EU of The European Parliament and of the Council of June 8, 2011 on the restriction of the use of certain hazardous substances in electrical and electronic equipment (EEE) - recast, unless otherwise specified as non-compliant.**

**Please note that some Vishay documentation may still make reference to RoHS Directive 2002/95/EC. We confirm that all the products identified as being compliant to Directive 2002/95/EC conform to Directive 2011/65/EU.**

**Vishay Intertechnology, Inc. hereby certifies that all its products that are identified as Halogen-Free follow Halogen-Free requirements as per JEDEC JS709A standards. Please note that some Vishay documentation may still make reference to the IEC 61249-2-21 definition. We confirm that all the products identified as being compliant to IEC 61249-2-21 conform to JEDEC JS709A standards.**