

Customer Information Sheet

DRAWING No.: G125-32496M5-XX-XX-00

IF IN DOUBT - ASK

©

NOT TO SCALE

THIRD ANGLE PROJECTION

ALL DIMENSIONS IN mm

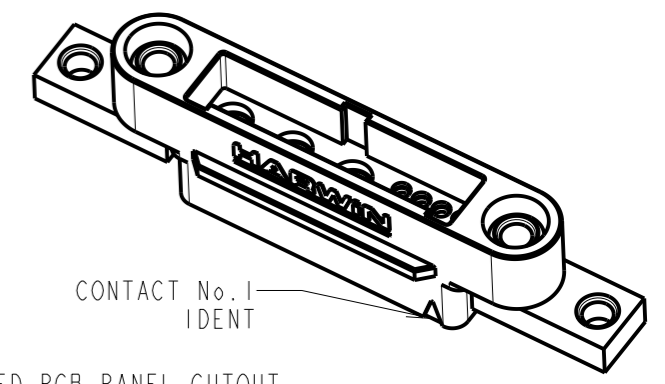
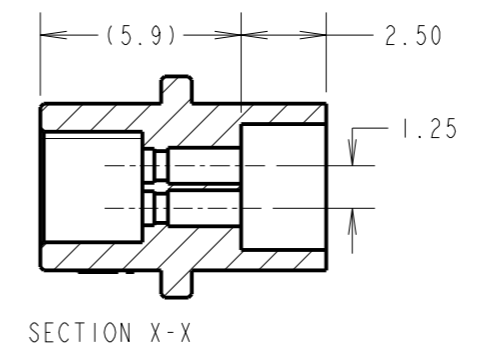
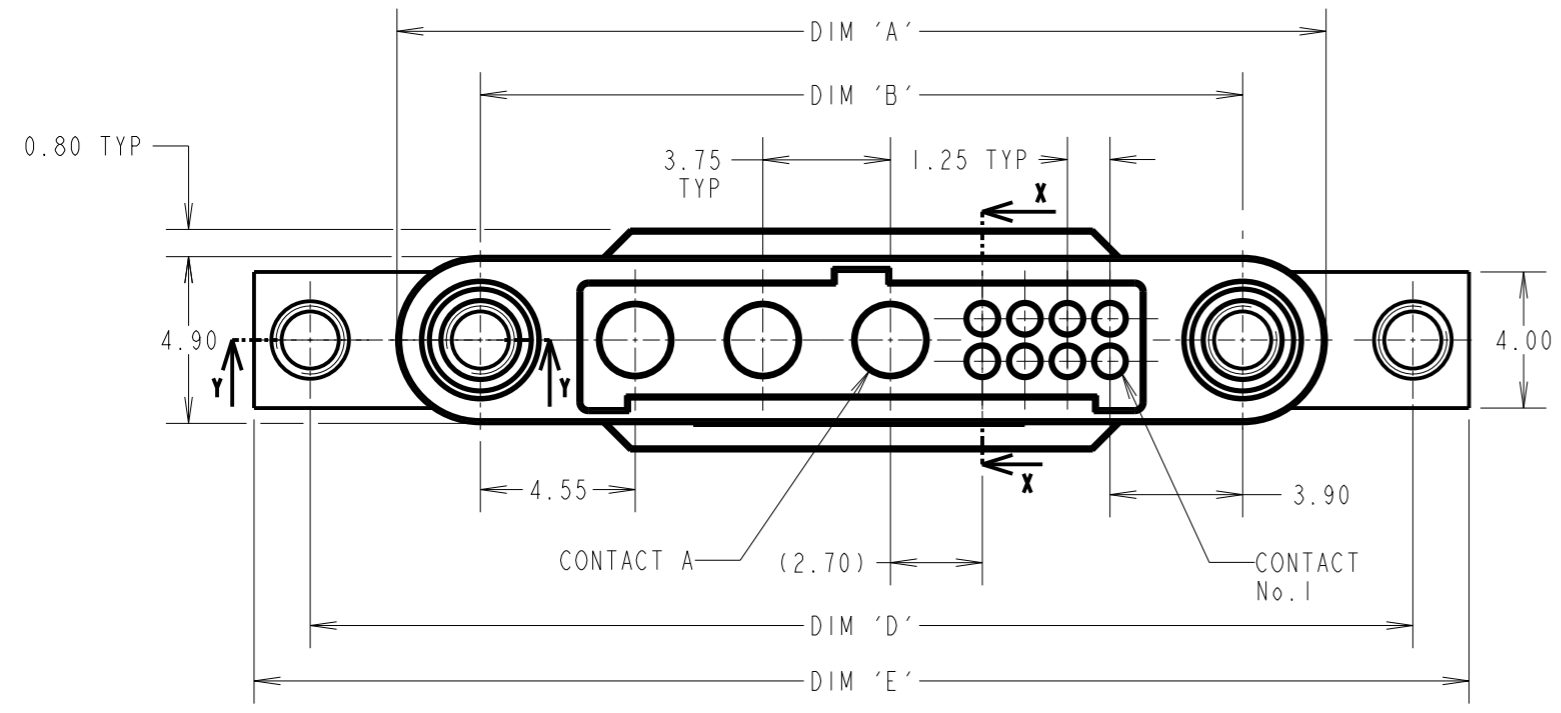

RECOMMENDED PCB PANEL CUTOUT
(ALL TOLERANCES ±0.05)

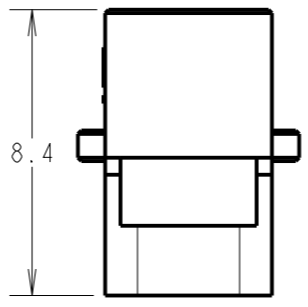
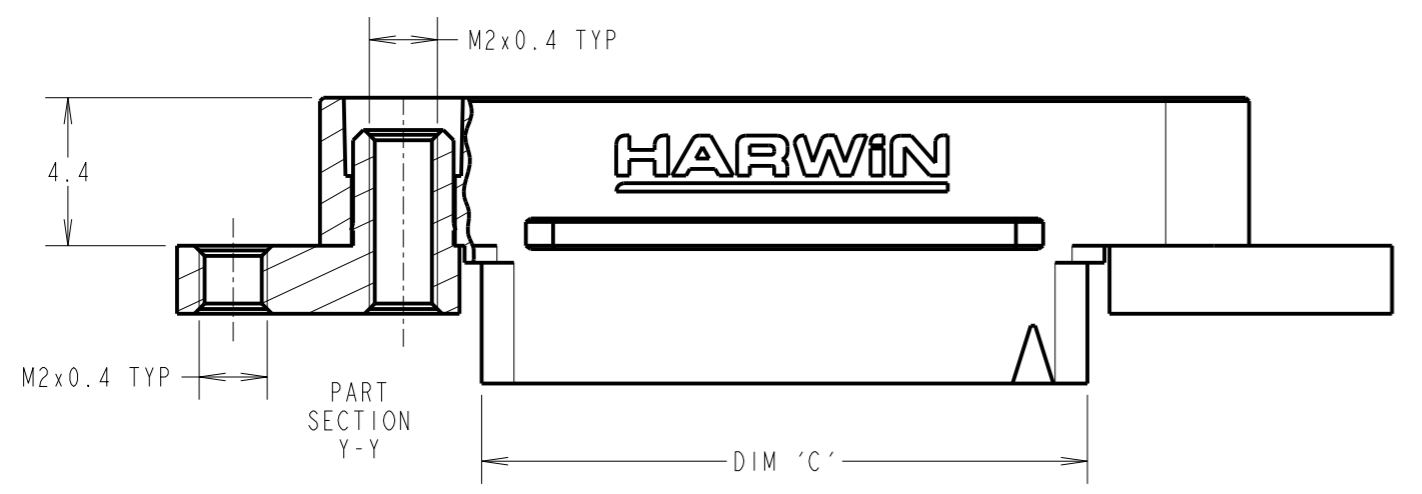
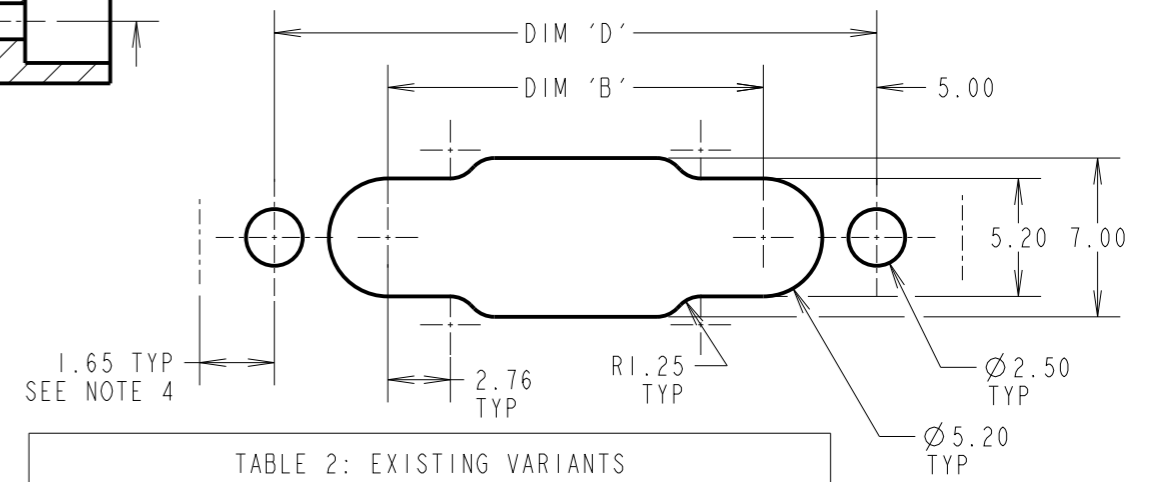

TABLE 2: EXISTING VARIANTS

PART No.	No. OF POWER CONTACTS	No. OF SIGNAL CONTACTS
G125-32496M5-02-04-00	02	04
G125-32496M5-03-08-00	03	08
G125-32496M5-04-04-00	04	04
G125-32496M5-02-24-00	02	24
G125-32496M5-04-16-00	04	16
G125-32496M5-06-08-00	06	08

TABLE 1: DIMENSION CALCULATIONS

DIMENSION	CALCULATION
DIM 'A'	$((\text{TOTAL No. OF SIGNAL CONTACTS} - 2) \times 0.625) + ((\text{TOTAL No. OF POWER CONTACTS} - 1) \times 3.75) + 16.05$
DIM 'B'	$((\text{TOTAL No. OF SIGNAL CONTACTS} - 2) \times 0.625) + ((\text{TOTAL No. OF POWER CONTACTS} - 1) \times 3.75) + 11.15$
DIM 'C'	$((\text{TOTAL No. OF SIGNAL CONTACTS} - 2) \times 0.625) + ((\text{TOTAL No. OF POWER CONTACTS} - 1) \times 3.75) + 6.60$
DIM 'D'	$((\text{TOTAL No. OF SIGNAL CONTACTS} - 2) \times 0.625) + ((\text{TOTAL No. OF POWER CONTACTS} - 1) \times 3.75) + 21.15$
DIM 'E'	$((\text{TOTAL No. OF SIGNAL CONTACTS} - 2) \times 0.625) + ((\text{TOTAL No. OF POWER CONTACTS} - 1) \times 3.75) + 24.45$

RTP	1	01.11.22	31971
NAME	ISS.	DATE	CN/CO
APPROVED: A.BOXALL			
CHECKED: M.RUDKIN			
DRAWN: R.PORTLOCK			
CUSTOMER REF.:			
ASSEMBLY DRG:			

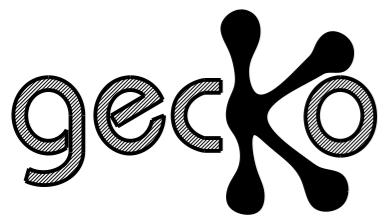

ORDER CODE:
G125-32496M5-XX-XX-00

No. OF POWER CONTACTS: SEE TABLE 2 No. OF SIGNAL CONTACTS: SEE TABLE 2

- NOTES:
- HOUSING TO BE USED WITH G125-1010005 OR G125-1020005 MALE SIGNAL CONTACTS, AND G125-1500005 MALE POWER CONTACT.
 - FOR ASSEMBLY INSTRUCTIONS SEE INSTRUCTION SHEET IS-38.
 - FOR MATERIALS, FINISH AND PERFORMANCE SEE COMPONENT SPECIFICATION C125XX (LATEST ISSUE).
 - CLEARANCE REQUIRED BEHIND PANEL FOR HARDWARE.
 - DRAWING SHOWING G125-32496M5-03-08-00.
 - RECOMMENDED HEX SCREW FOR MONTING ON PANELS UP TO 3MM MAX THICKNESS: G125-4520000B.

HARWIN

www.harwin.com
technical@harwin.com

THIS DRAWING AND ANY INFORMATION OR DESCRIPTIVE MATTER SET OUT HEREON ARE CONFIDENTIAL AND COPYRIGHT PROPERTY OF THE HARWIN GROUP AND MUST NOT BE DISCLOSED, LOANED, COPIED OR USED FOR MANUFACTURING, TENDERING OR FOR ANY OTHER PURPOSE WITHOUT THEIR WRITTEN PERMISSION.

TOLERANCES
X. = ±1mm
X.X = ±0.50mm
X.XX = ±0.20mm
X.XXX = ±0.01mm
ANGLES = ±5°
UNLESS STATED

MATERIAL:
SEE NOTE 3

FINISH:
S/AREA: mm²

TITLE:
GECKO-MT MALE CABLE HOUSING

DRAWING NUMBER:
G125-32496M5-XX-XX-00

SHT 2 OF 2