

LOC	DIST	REV	DATE	DWN	APVD
AD	00	0	30SEP2004	BC	RW
		A	10JUL2006	DH	DB

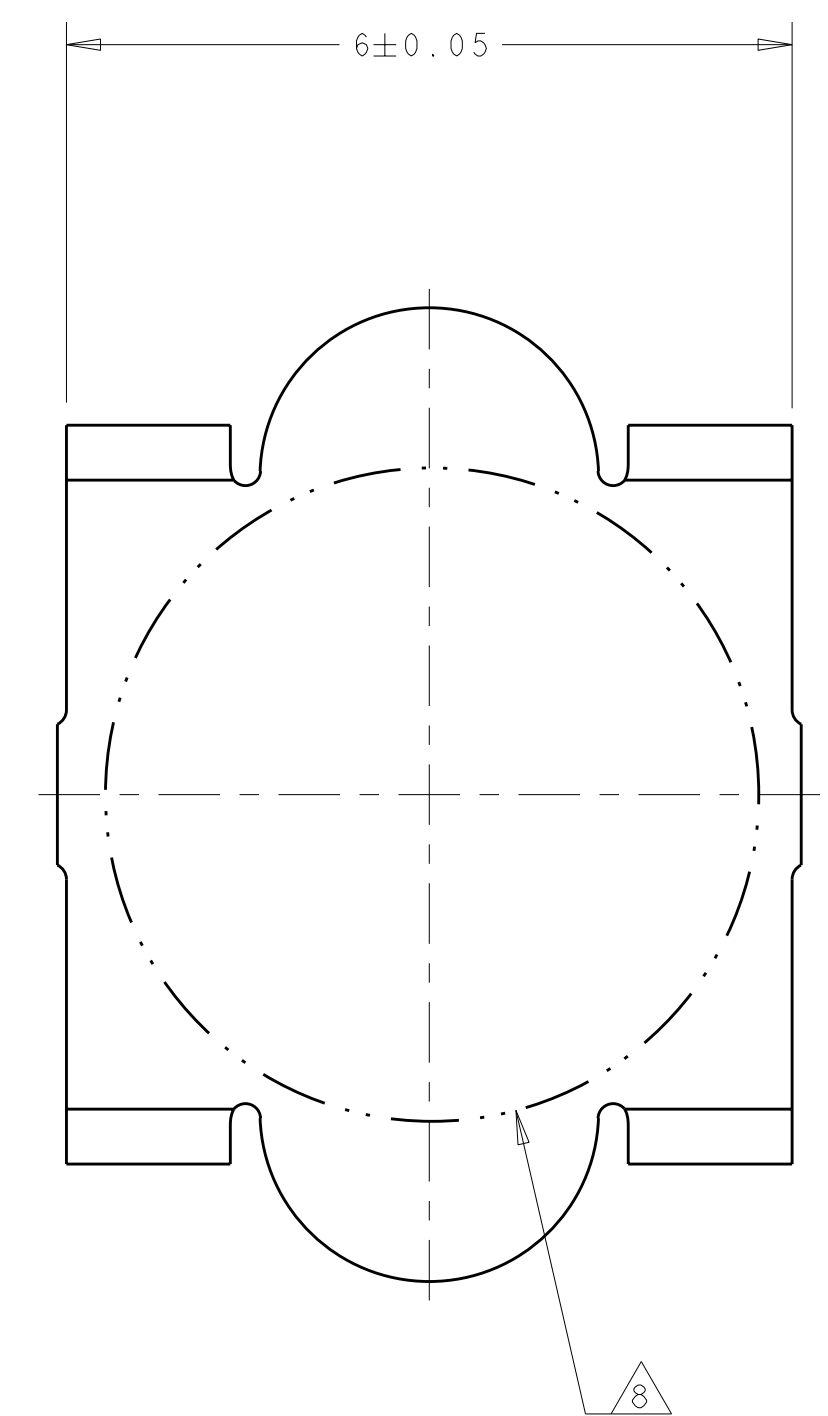

VACUUM COVER

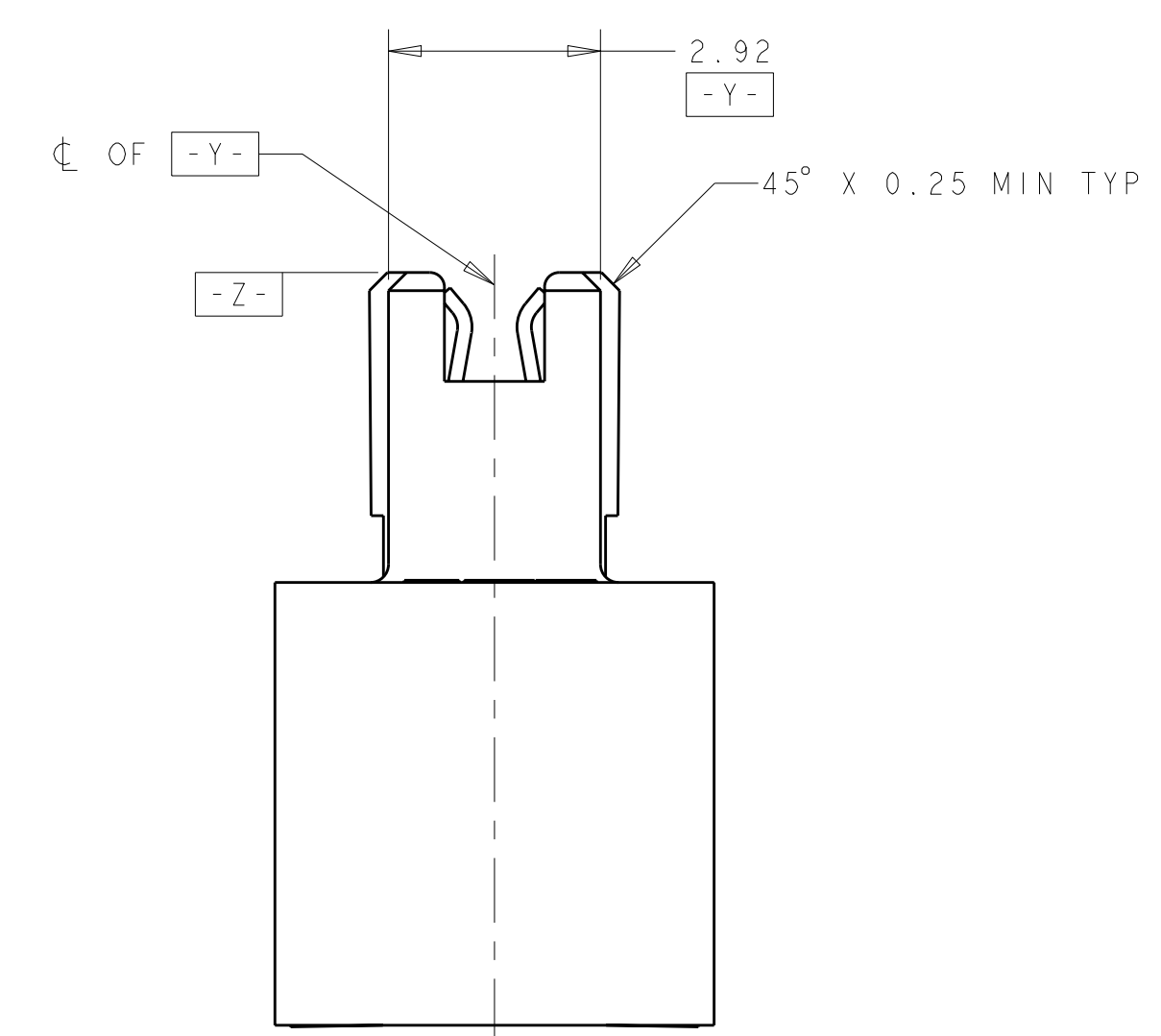
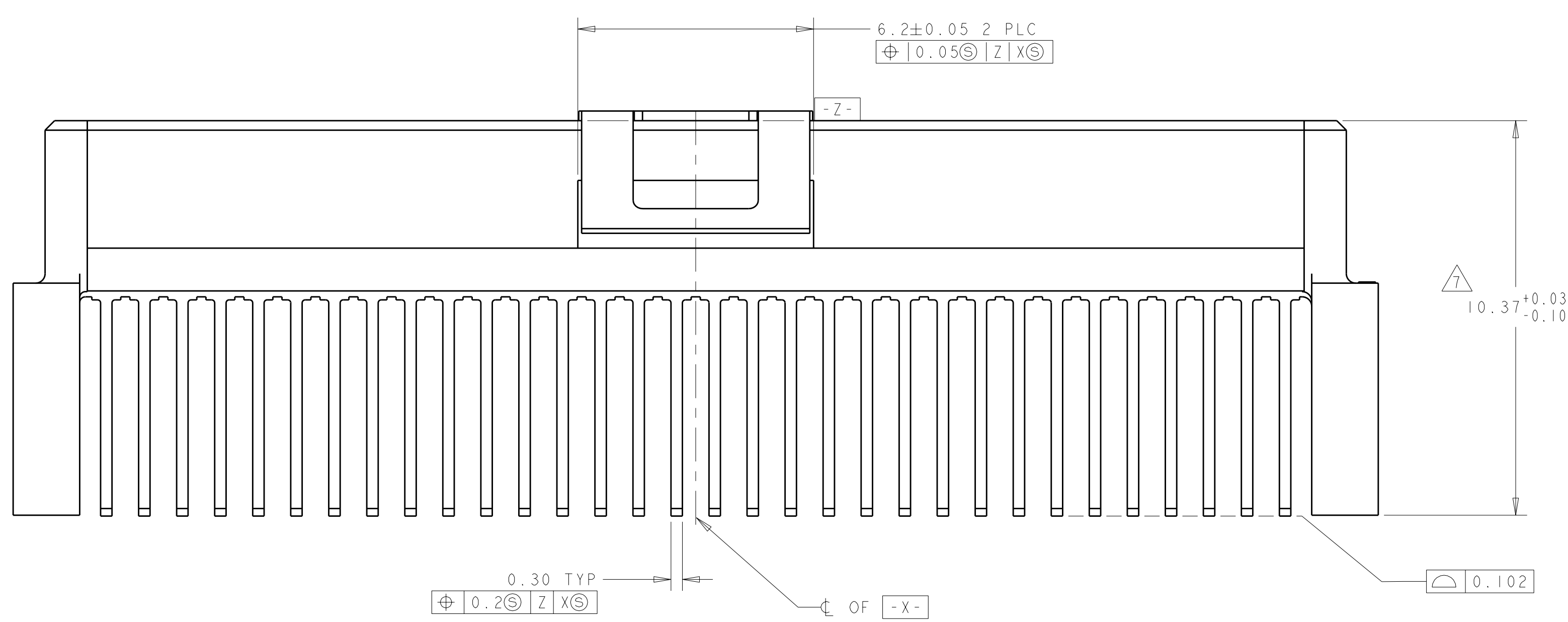
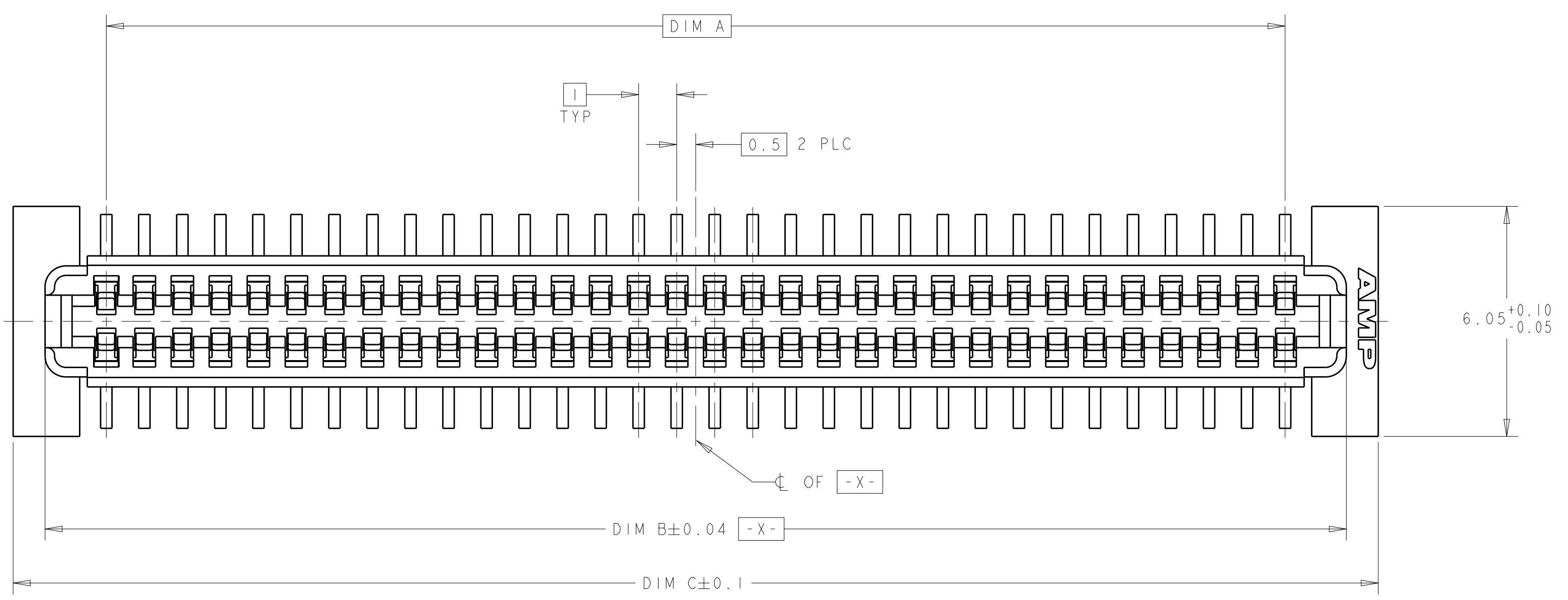
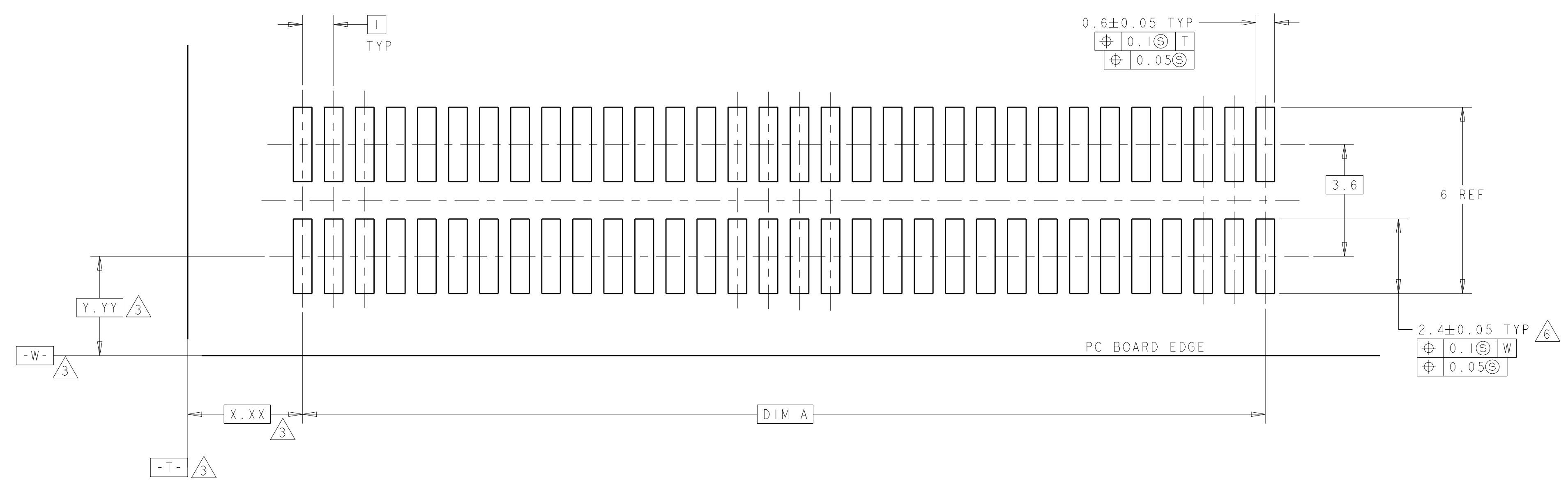

RECOMMENDED PC BOARD LAYOUT

- 1 HOUSING MATERIAL: HIGH TEMPERATURE THERMOPLASTIC, COLOR: BLACK. CONTACT MATERIAL: PHOSPHOR BRONZE.
- 2 CONTACT FINISH: NICKEL UNDERPLATE ALL OVER, MATING SURFACES PLATED TO MEET PLI PERFORMANCE REQUIREMENTS OF INDUSTRY SPECIFICATION EIA-700AAAAB, SOLDER TAILS PLATED TIN.
- 3 DATUM LOCATIONS AND BASIC DIMENSIONS TO BE ESTABLISHED BY THE CUSTOMER. CONSULT AMP ENGINEERING WHEN PLACING MULTIPLE CONNECTORS ON A PC BOARD.
- 4 PACKAGED IN TAPE ON REEL PER EIA-481.
- 5 VACUUM COVER DESIGNED FOR 4mm DIA. NOZZLE. COVER TO BE REMOVED AFTER SOLDERING. VACUUM COVER OMITTED FROM SOME VIEWS FOR DIMENSIONAL CLARITY.
- 6 SHORTER SOLDER LANDS MAY BE USED PER EIA 700AAAAB, HOWEVER 2.4 LENGTH ASSURES OPTIMUM SOLDER FILLET REGARDLESS OF MANUFACTURER OF CONNECTOR.
- 7 REFERRED TO AS DIM H = 10.30 ± 0.1 IN EIA 700AAAAB SPECIFICATION.
- 8 5.5 MIN DIAMETER TARGET AREA FOR VACUUM PICK-UP.
- 9 CONTACT FINISH: 0.00381 MINIMUM MATTE TIN PER ASTM B 545 ON SOLDER AREA, 0.00127 MINIMUM GOLD PER ASTM B 488 ON MATING AREA, BOTH OVER 0.00127 MINIMUM NICKEL PER SAE-AMS-QQ-N-290 ON ENTIRE CONTACT.

FINISH	DIM C	DIM B	DIM A	MATING CONNECTOR	STACK HGTS	POS	PART NO
9	45.9	44.22	41	5120534-2	15	84	1-5120531-2
9	45.9	44.22	41	5120533-2	14	84	1-5120531-2
9	35.9	34.22	31	5120534-1	15	64	1-5120531-1
9	35.9	34.22	31	5120533-1	14	64	1-5120531-1
2	45.9	44.22	41	5120534-2	15	84	5120531-2
2	45.9	44.22	41	5120533-2	14	84	5120531-2
2	35.9	34.22	31	5120534-1	15	64	5120531-1
2	35.9	34.22	31	5120533-1	14	64	5120531-1

DIMENSIONS: mm 9 PLC ± 4 PLC ±0.03 5 PLC ±0.003 4 PLC ± ANGLES 40°-1° FINISH SEE TABLE		TOLERANCES UNLESS OTHERWISE SPECIFIED: 30SEP04 30SEP04 30SEP04 PRODUCT SPEC 502-1079 APPLICATION SPEC 114-25045 WEIGHT CUSTOMER DRAWING		DWN B. CARBO CHK R. WERTZ APVD R. WERTZ NAME RCPT ASSY, W/COVER, 1.0mm FH(IEEE1386) CONNECTOR SIZE CAGE CODE DRAWING NO RESTRICTED TO A11 00779 C=5120531 SCALE 10:1 SHEET 1 OF 1 REV A		Tyco Electronics Harrisburg, PA 17105-3608	
--	--	--	--	--	--	---	--