

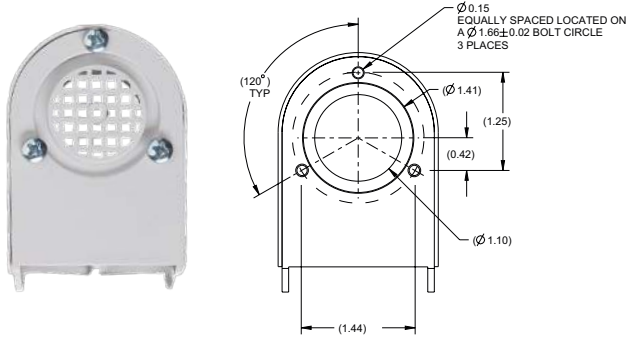

COOLING OPTIONS

VENT-2

Part Number	Description
Vent-2	Outdoor Vent - Labyrinth, non-metallic vent



VENT-3

Part Number	Description
Vent-3	Aluminum Vent - Louvered, aluminum vent

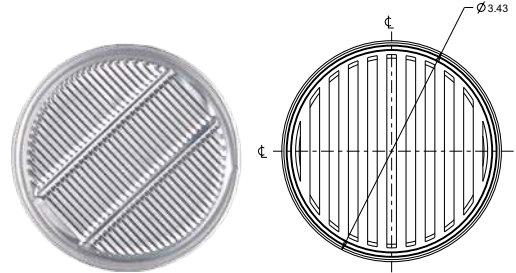

FAN SHROUD VENT FILTER KITS

Part Number	Description
FSFK1-G	Fan Shroud Vent Filter Kit Gray - one piece
FSFK2-G	Fan Shroud Vent Filter Kit Gray - two pieces

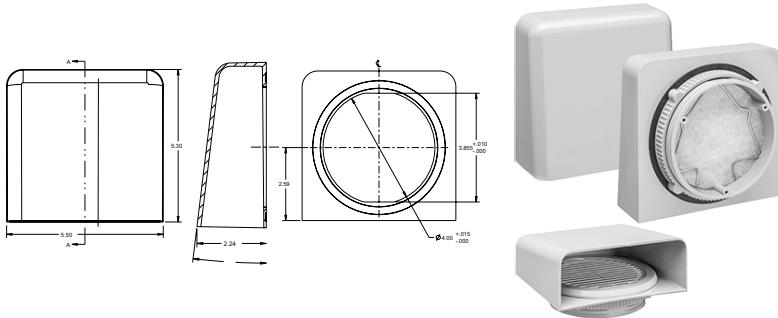

GORE VENTS

Part Number	Description
VENT-POLY-GRY	Gore Vent Kit - Gray

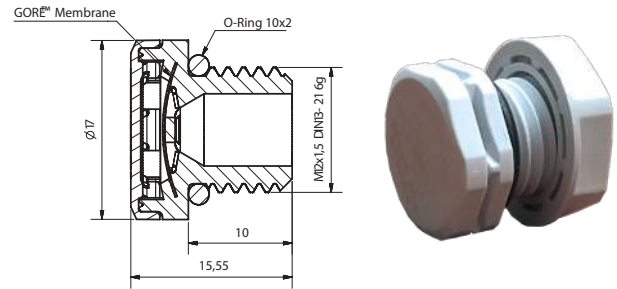

THE INTEGRA FAMILY



PREMIUM LINE

This enclosure is designed for any electrical application and boasts a very high-impact resistance of 900 in-lbs.



IMPACT® LINE

This 100% polycarbonate enclosure can be custom designed and offers superior corrosion-resistance.



GENESIS LINE

Integra's largest 24x24x10 polycarbonate enclosure with best in class hinge and multiple mounting surfaces make it ideal for any application.



STRONGBOX LINE

Integra's new stainless steel and aluminum product line. Integra's StrongBox enclosures specialize in custom sizes and configurations to tailor to any need.