

## Description

The IDT5V50015 generates a low EMI output clock from a clock or crystal input. The part is designed to dither the LCD interface clock for PDAs, printers, scanners, modems, copiers, and others. Using IDT's proprietary mix of analog and digital Phase-Locked Loop (PLL) technology, the device spreads the frequency spectrum of the output, reducing the frequency amplitude peaks by several dB.

IDT offers many other clocks for computers and computer peripherals. Consult IDT when you need to remove crystals and oscillators from your board.

## Features

- Packaged in 8-pin SOIC/TSSOP
- Provides a spread spectrum output clock
- 135 MHz to 200 MHz operation
- Accepts a clock input (provides same frequency dithered output)
- Center spread modulation
- Peak reduction by 8 dB to 16 dB typical on 3rd through 19th odd harmonics
- Low EMI feature can be disabled
- Operating voltage of 3.3 V
- Advanced, low-power CMOS process

## Block Diagram

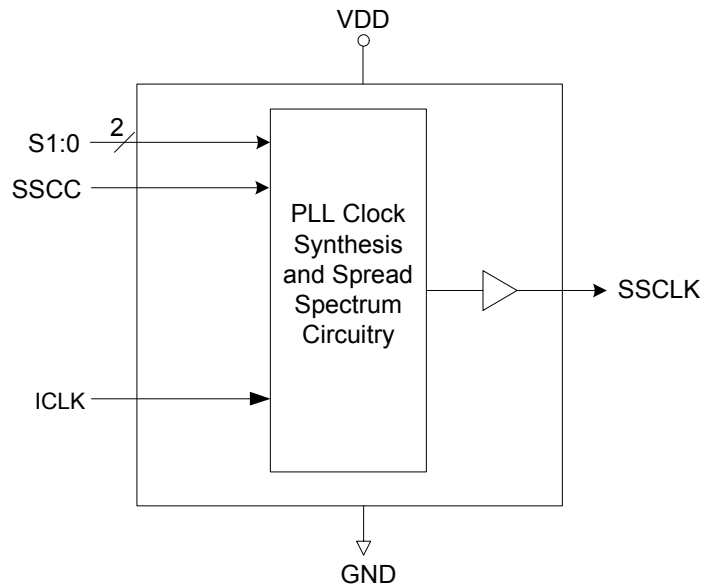

## Pin Assignment

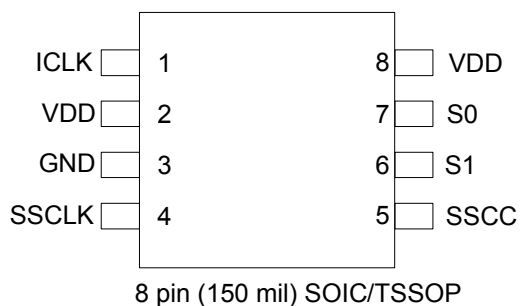

## Spread Direction and Percentage Select Table

S1 Pin 6	S0 Pin 7	Spread Direction	Spread Percentage
0	0	Center	±0.5
0	1	Center	±1.0
1	0	Center	±1.5
1	1	Center	±2.0

0 = connect to GND  
1 = connect directly to VDD

## Pin Descriptions

Pin Number	Pin Name	Pin Type	Pin Description
1	ICLK	Input	Connect to a 130–200 MHz clock input.
2	VDD	Power	Connect to +3.3 V.
3	GND	Power	Connect to ground.
4	SSCLK	Output	Clock output with spread spectrum.
5	SSCC	Input	Spread spectrum enable/disable function. SSCC function is enabled when input is high and disabled when input is low. This pin is pulled high internally.
6	S1	Input	Function select 1 input. Selects spread amount and direction per table above. Internal pull-down.
7	S0	Input	Function select 0 input. Selects spread amount and direction per table above. Internal pull-down.
8	VDD	Power	Connect to +3.3 V.

## External Components

The IDT5V50015 requires a minimum number of external components for proper operation.

### Decoupling Capacitor

A decoupling capacitor of  $0.01\mu\text{F}$  must be connected between VDD and GND on pins 2 and 3, as close to these pins as possible. For optimum device performance, the decoupling capacitor should be mounted on the component side of the PCB. Avoid the use of vias in the decoupling circuit.

### Series Termination Resistor

When the PCB trace between the clock output and the load is over 1 inch, series termination should be used. To series terminate a  $50\Omega$  trace (a commonly used trace impedance) place a  $33\Omega$  resistor in series with the clock line, as close to the clock output pin as possible. The nominal impedance of the clock output is  $20\Omega$ .

## PCB Layout Recommendations

For optimum device performance and lowest output phase noise, the following guidelines should be observed.

- 1) The  $0.01\mu\text{F}$  decoupling capacitor should be mounted on the component side of the board as close to the VDD pin as possible. No vias should be used between the decoupling capacitor and VDD pin. The PCB trace to VDD pin should be kept as short as possible, as should the PCB trace to the ground via.
- 2) To minimize EMI, the  $33\Omega$  series termination resistor (if needed) should be placed close to the clock output.
- 3) An optimum layout is one with all components on the same side of the board, minimizing vias through other signal layers. Other signal traces should be routed away from the IDT5V50015. This includes signal traces just underneath the device, or on layers adjacent to the ground plane layer used by the device.

## Spread Spectrum Profile

The IDT5V50015 low EMI clock generator uses an optimized frequency slew rate algorithm to facilitate down stream tracking of zero delay buffers and other PLL devices. The frequency modulation amplitude is constant with variations of the input frequency.

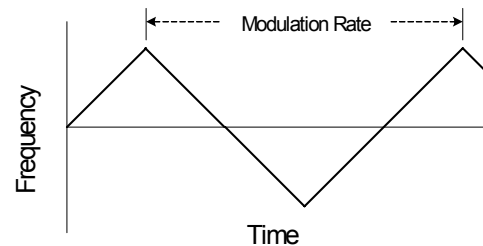

## Absolute Maximum Ratings

Stresses above the ratings listed below can cause permanent damage to the IDT5V50015. These ratings, which are standard values for IDT commercially rated parts, are stress ratings only. Functional operation of the device at these or any other conditions above those indicated in the operational sections of the specifications is not implied. Exposure to absolute maximum rating conditions for extended periods can affect product reliability. Electrical parameters are guaranteed only over the recommended operating temperature range.

Item	Rating
Supply Voltage, VDD	7 V
All Inputs and Outputs	-0.5 V to VDD+0.5 V
Ambient Operating Temperature	0 to +70° C
Storage Temperature	-65 to +150° C
Junction Temperature	125° C
Soldering Temperature	260° C

## Recommended Operation Conditions

Parameter	Min.	Typ.	Max.	Units
Ambient Operating Temperature	0		+70	°C
Power Supply Voltage (measured in respect to GND)	+3.0		3.6	V

## Thermal Characteristics for 8TSSOP

Parameter	Symbol	Conditions	Min.	Typ.	Max.	Units
Thermal Resistance Junction to Ambient	$\theta_{JA}$	Still air		110		°C/W
	$\theta_{JA}$	1 m/s air flow		100		°C/W
	$\theta_{JA}$	3 m/s air flow		80		°C/W
Thermal Resistance Junction to Case	$\theta_{JC}$			35		°C/W

## Thermal Characteristics for 8SOIC

Parameter	Symbol	Conditions	Min.	Typ.	Max.	Units
Thermal Resistance Junction to Ambient	$\theta_{JA}$	Still air		150		°C/W
	$\theta_{JA}$	1 m/s air flow		140		°C/W
	$\theta_{JA}$	3 m/s air flow		120		°C/W
Thermal Resistance Junction to Case	$\theta_{JC}$			40		°C/W
Thermal Resistance Junction to Top of Case	$\Psi_{JT}$	Still air		20		°C/W

## DC Electrical Characteristics

Unless stated otherwise, **VDD = 3.3 V**, Ambient Temperature 0 to +70° C

Parameter	Symbol	Conditions	Min.	Typ.	Max.	Units
Operating Voltage	VDD		3.0	3.3	3.6	V
Supply Current	IDD	ICLK=150 MHz, Note 1		40		mA
		ICLK=200 MHz, Note 1		50		mA
Input High Voltage	V <sub>IH</sub>	S1: S0	2.0			V
Input Low Voltage	V <sub>IL</sub>	S1: S0			0.8	V
Output High Voltage	V <sub>OH</sub>	I <sub>OH</sub> = -6 mA	2.4			V
		I <sub>OH</sub> = -20 mA	2.0			V
Output Low Voltage	V <sub>OL</sub>	I <sub>OL</sub> = 6 mA			0.4	V
		I <sub>OL</sub> = 20 mA			1.2	V
Input Capacitance	C <sub>IN1</sub>	All inputs	3	4	5	pF
Pull-down Resistance	R <sub>PD</sub>	S1, S0		240		kΩ
Pull-up Resistance	R <sub>PU</sub>	SSCC		240		kΩ

**Note 1:** CL = 15 pF.

## AC Electrical Characteristics

Unless stated otherwise, **VDD = 3.3 V**, Ambient Temperature 0 to +70° C

Parameter	Symbol	Conditions	Min.	Typ.	Max.	Units
Input Clock Frequency			135		200	MHz
Output Clock Frequency			135		200	MHz
Output Clock Duty Cycle		All outputs	47	50	53	%
Cycle to cycle Jitter		ICLK=150 MHz, SS on		50	100	ps
		ICLK=200 MHz, SS on		75	100	ps
Output Rise Time	t <sub>R</sub>	20% to 80%, CL=15 pF, 150 MHz		0.9		ns
Output Fall Time	t <sub>F</sub>	80% to 20%, CL=15 pF, 150 MHz		0.9		ns
Modulation Frequency		ICLK=200 MHz		51.2		kHz
		ICLK=150 MHz		38.4		
		ICLK=130 MHz		32		

## Package Outline and Package Dimensions (8-pin TSSOP)

Package dimensions are kept current with JEDEC Publication No. 95

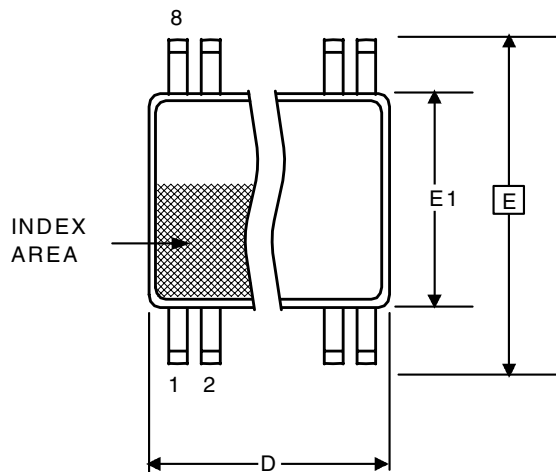

Symbol	Millimeters		Inches	
	Min	Max	Min	Max
A	--	1.20	--	0.047
A1	0.05	0.15	0.002	0.006
A2	0.80	1.05	0.032	0.041
b	0.19	0.30	0.007	0.012
C	0.09	0.20	0.0035	0.008
D	2.90	3.10	0.114	0.122
E	6.40 BASIC		0.252 BASIC	
E1	4.30	4.50	0.169	0.177
e	0.65 Basic		0.0256 Basic	
L	0.45	0.75	0.018	0.030
$\alpha$	0°	8°	0°	8°
aaa	-	0.10	-	0.004

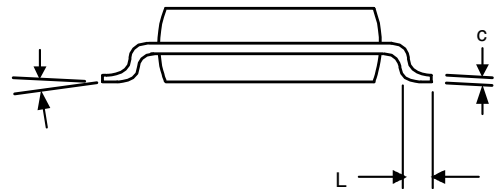
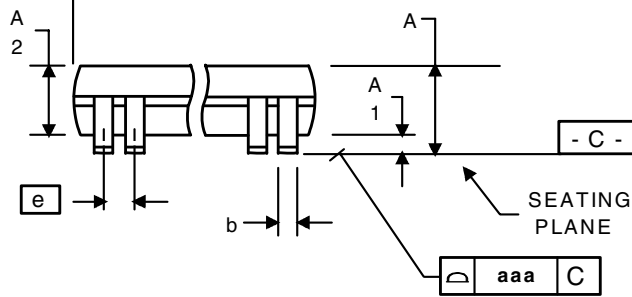

## Package Outline and Package Dimensions (8-pin SOIC, 150 Mil. Body)

Package dimensions are kept current with JEDEC Publication No. 95

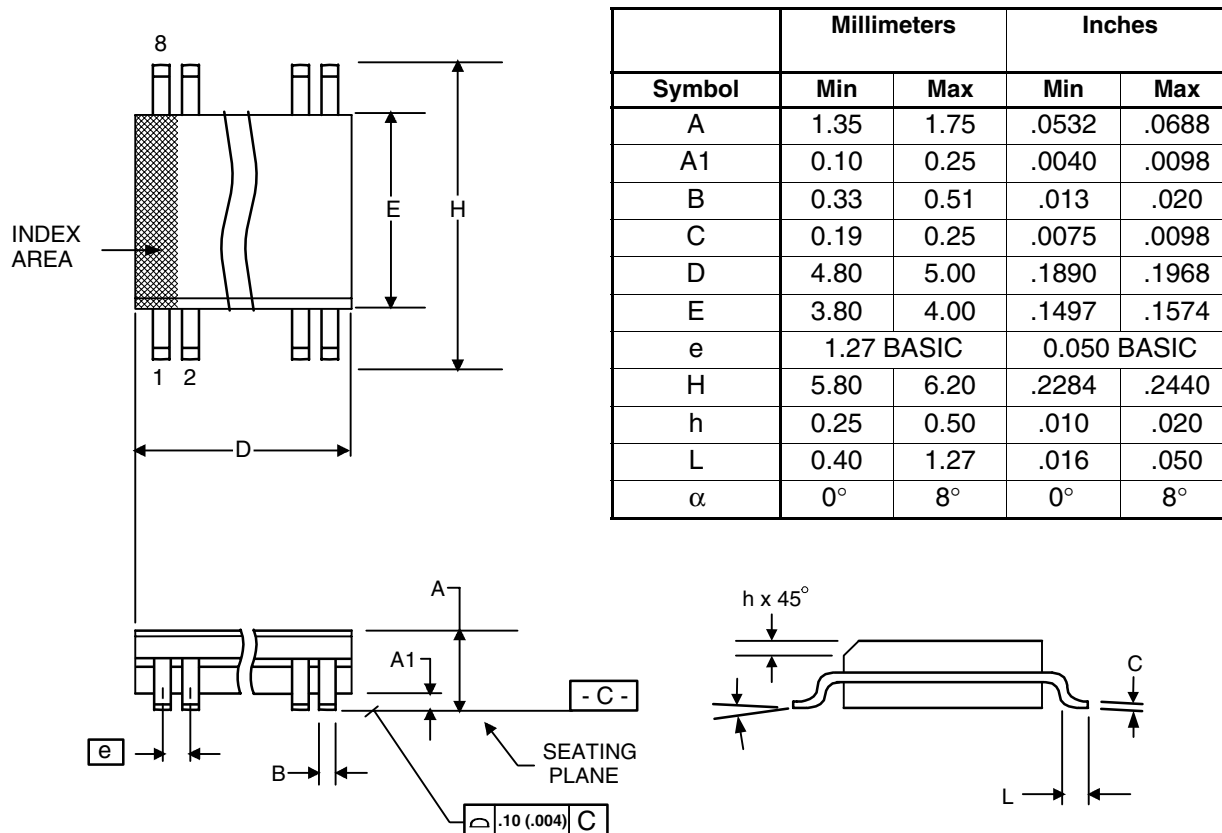

## Ordering Information

Part / Order Number	Marking	Shipping Packaging	Package	Temperature
5V50015PGG	TBD	Tubes	8-pin TSSOP	0 to +70° C
5V50015PGG8		Tape and Reel	8-pin TSSOP	0 to +70° C
5V50015DCG	TBD	Tubes	8-pin SOIC	0 to +70° C
5V50015DCG8		Tape and Reel	8-pin SOIC	0 to +70° C

Parts that are ordered with a "G" after the two-letter package code are the Pb-Free configuration and are RoHS compliant.

While the information presented herein has been checked for both accuracy and reliability, Integrated Device Technology (IDT) assumes no responsibility for either its use or for the infringement of any patents or other rights of third parties, which would result from its use. No other circuits, patents, or licenses are implied. This product is intended for use in normal commercial applications. Any other applications such as those requiring extended temperature range, high reliability, or other extraordinary environmental requirements are not recommended without additional processing by IDT. IDT reserves the right to change any circuitry or specifications without notice. IDT does not authorize or warrant any IDT product for use in life support devices or critical medical instruments.

## Revision History

Rev.	Originator	Date	Description of Change
E		01/28/09	Release to final.
F		03/11/09	Changed minimum input frequency from 130 to 135 MHz.





## IMPORTANT NOTICE AND DISCLAIMER

RENESAS ELECTRONICS CORPORATION AND ITS SUBSIDIARIES (“RENESAS”) PROVIDES TECHNICAL SPECIFICATIONS AND RELIABILITY DATA (INCLUDING DATASHEETS), DESIGN RESOURCES (INCLUDING REFERENCE DESIGNS), APPLICATION OR OTHER DESIGN ADVICE, WEB TOOLS, SAFETY INFORMATION, AND OTHER RESOURCES “AS IS” AND WITH ALL FAULTS, AND DISCLAIMS ALL WARRANTIES, EXPRESS OR IMPLIED, INCLUDING, WITHOUT LIMITATION, ANY IMPLIED WARRANTIES OF MERCHANTABILITY, FITNESS FOR A PARTICULAR PURPOSE, OR NON-INFRINGEMENT OF THIRD PARTY INTELLECTUAL PROPERTY RIGHTS.

These resources are intended for developers skilled in the art designing with Renesas products. You are solely responsible for (1) selecting the appropriate products for your application, (2) designing, validating, and testing your application, and (3) ensuring your application meets applicable standards, and any other safety, security, or other requirements. These resources are subject to change without notice. Renesas grants you permission to use these resources only for development of an application that uses Renesas products. Other reproduction or use of these resources is strictly prohibited. No license is granted to any other Renesas intellectual property or to any third party intellectual property. Renesas disclaims responsibility for, and you will fully indemnify Renesas and its representatives against, any claims, damages, costs, losses, or liabilities arising out of your use of these resources. Renesas' products are provided only subject to Renesas' Terms and Conditions of Sale or other applicable terms agreed to in writing. No use of any Renesas resources expands or otherwise alters any applicable warranties or warranty disclaimers for these products.

(Disclaimer Rev.1.0 Mar 2020)

### Corporate Headquarters

TOYOSU FORESIA, 3-2-24 Toyosu,  
Koto-ku, Tokyo 135-0061, Japan  
[www.renesas.com](http://www.renesas.com)

### Contact Information

For further information on a product, technology, the most up-to-date version of a document, or your nearest sales office, please visit:  
[www.renesas.com/contact/](http://www.renesas.com/contact/)

### Trademarks

Renesas and the Renesas logo are trademarks of Renesas Electronics Corporation. All trademarks and registered trademarks are the property of their respective owners.