

REVISIONS					
P	LTR	DESCRIPTION	DATE	DWN	APVD
A1		REVISED PER PCN E-20-006830	12MAY2020	DB	IG
A2		REVISED PER PCN E-20-009832	09JUL2020	DB	IG
A3		REVISED PER PCN E-20-010705	28JUL2020	DB	IG
A4		REVISED PER PCN E-21-000918	22JAN2021	DB	IG

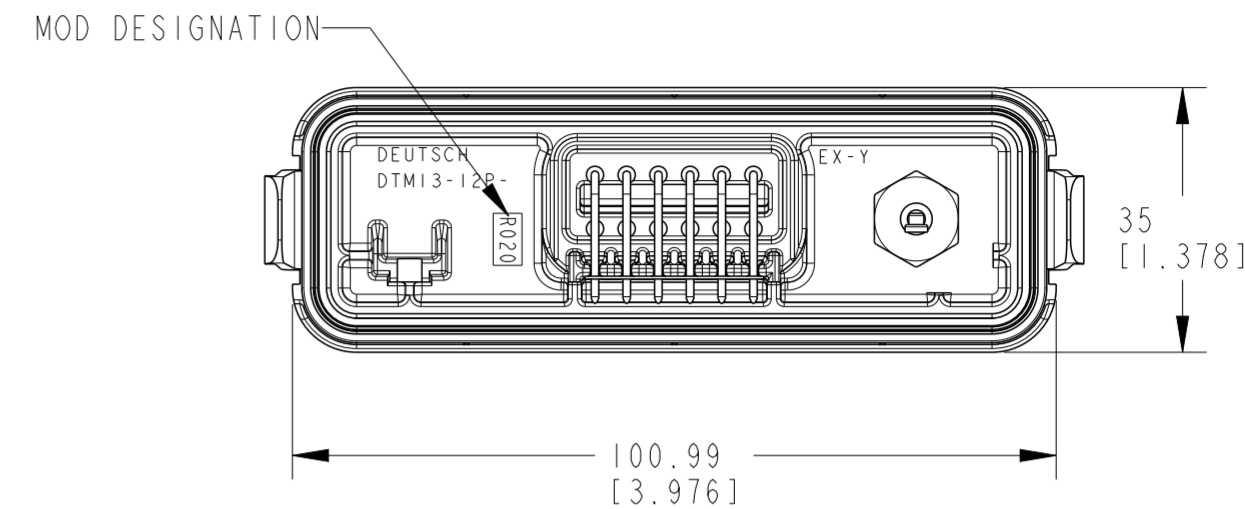

SECTION A-A

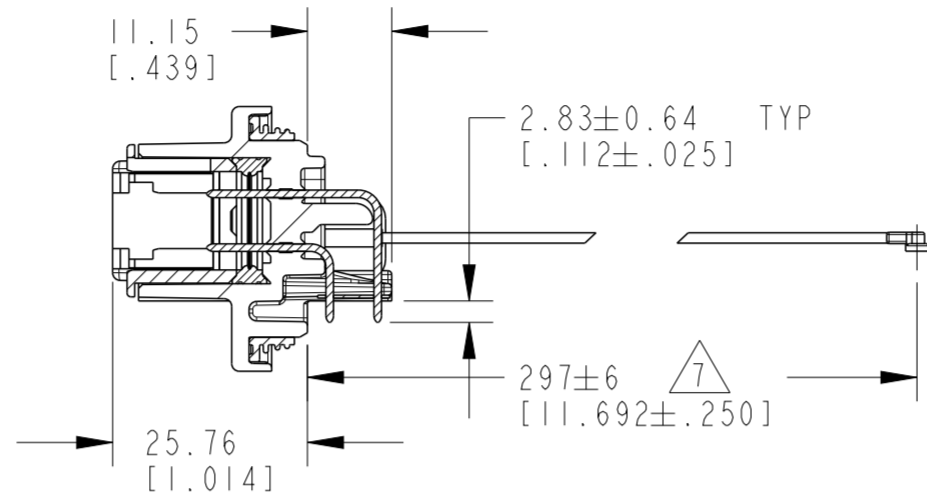
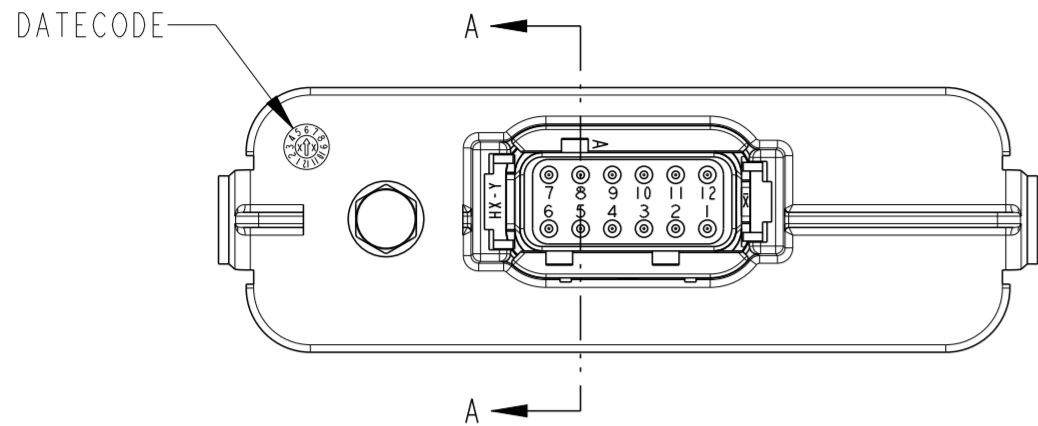
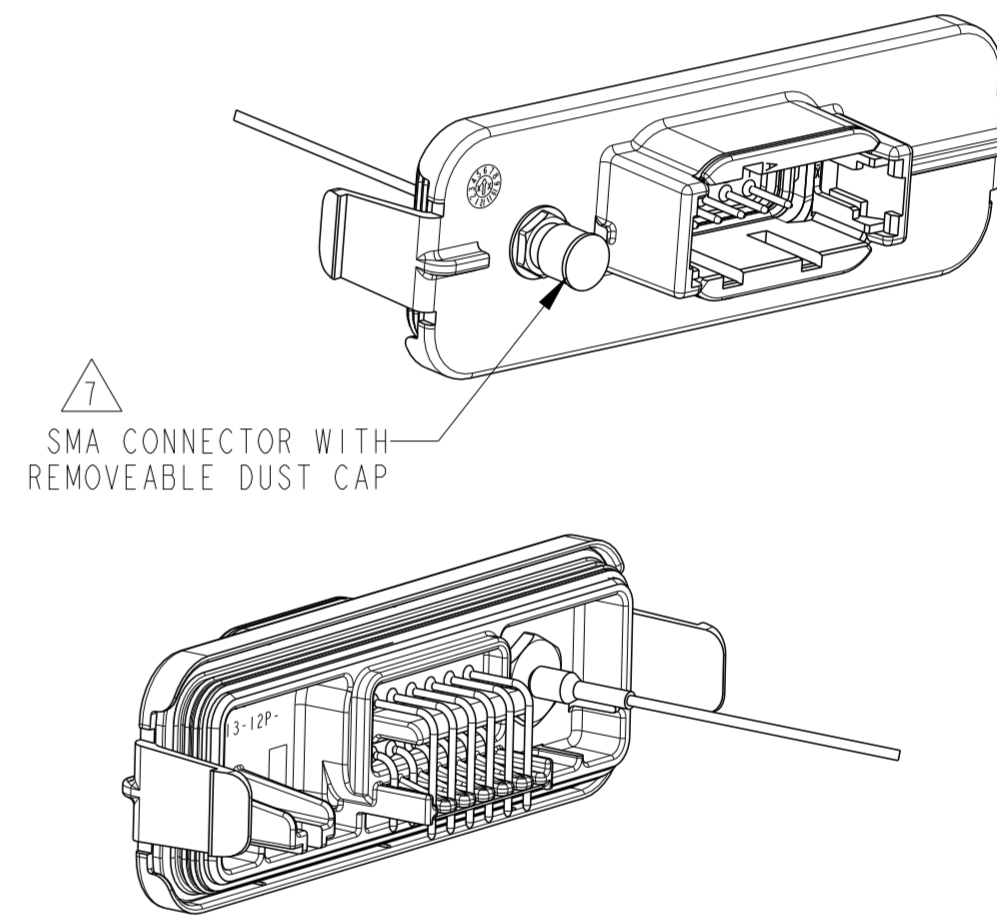
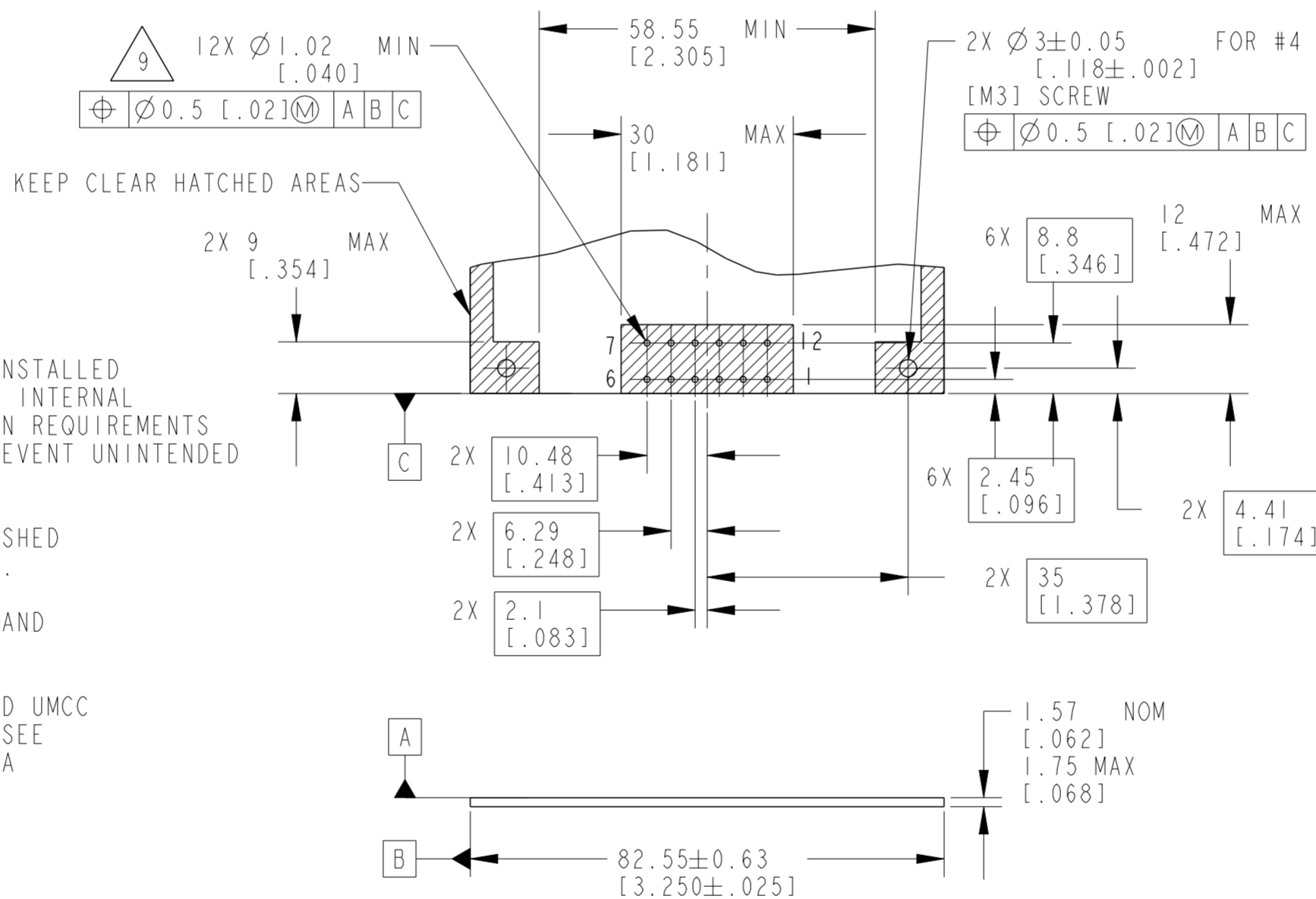
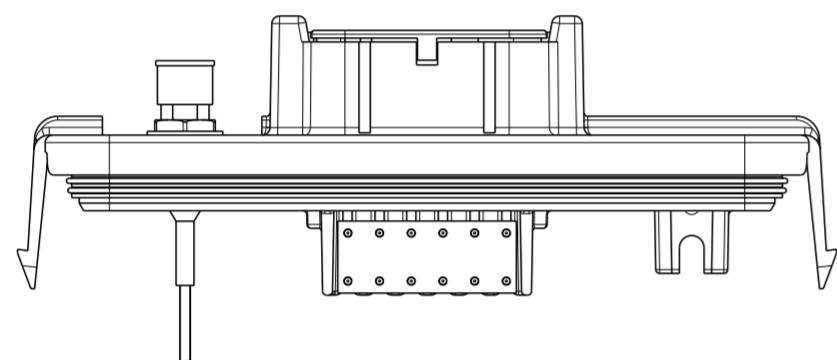

3D VIEWS

TCPN	ALIAS PART NUMBER
2333581-1	DTM13-12PA-R020
2333581-2	DTM13-12PB-R020
2333581-3	DTM13-12PC-R020
2333581-4	DTM13-12PD-R020

10. SEE PRODUCT SPEC 108-151090 FOR PERFORMANCE RATINGS. PERFORMANCE RATINGS MAY BE REDUCED WITH RESPECT TO THE INSTALLED SMA CONNECTOR. THE SMA PANEL NUT HAS BEEN TORQUED TO MEET INTERNAL PERFORMANCE RATINGS, HOWEVER CUSTOMER SPECIFIC APPLICATION REQUIREMENTS MAY REQUIRE ADDITIONAL PROCESSING AND/OR COMPONENTS TO PREVENT UNINTENDED LOOSENING OF THE PANEL NUT AND REDUCED SEAL PERFORMANCE.

9. MINIMUM RECOMMENDED HOLE SIZE. CUSTOMER TO DETERMINE FINISHED HOLE SIZE BASED ON SOLDER PROCESS, THRU-HOLE PLATING, ETC.

8. SEE DRAWING EEC-325X4A/B FOR FULL PCB SIZE SPECIFICATION AND COMPONENT HEIGHT RESTRICTIONS.

7. SMA CONNECTOR INCLUDES 297±6 mm [11.692±.250 in] CABLE AND UMCC CONNECTOR APPLIED TO END OF CABLE FOR CONNECTION TO PCB. SEE DRAWING 2016457 FOR FULL SMA CONNECTOR SPECIFICATIONS. SMA CONNECTOR IS SUPPLIED WITH REMOVEABLE DUST CAP.

6. SEE SHEET 2 FOR OTHER KEY ARRANGEMENTS.

5. THIS RECEPTACLE IS USED WITH EEC-325X4(A OR B) ENCLOSURE. SEE ENVELOPE DRAWING EEC-325X4A/EEC-325X4B FOR ENCLOSURE INFORMATION.

4. THIS RECEPTACLE MATES WITH DTM06-12S*-**** PLUG. (* = A,B,C,D KEYS; **** = ALL MODIFICATIONS).

3. MATERIAL: HOUSING: PA46 GF30 BLACK; SEALS: SILICONE RUBBER; CONTACTS: COPPER ALLOY.

2. CONTACT PLATING: MATING SIDE: NICKEL; PCB SIDE: TIN.

1. DIMENSIONS ARE IN MILLIMETERS [IN].

NOTES: UNLESS OTHERWISE SPECIFIED

PCB FOOTPRINT AND KEEP CLEAR AREAS

THIS DRAWING IS A CONTROLLED DOCUMENT.		DWN K. McKEE 23MAR2018	TE Connectivity	
DIMENSIONS: mm [in]		CHK K. McKEE 20AUG2018		
TOLERANCES UNLESS OTHERWISE SPECIFIED:		APVD D. MEYER 20AUG2018	NAME RECEPTACLE HEADER 12 POS, #20 SIZE CONTACT R020 MOD, DTM SERIES	
0 PLC ±		PRODUCT SPEC	SIZE	RESTRICTED TO
1 PLC ±		APPLICATION SPEC	CAGE CODE	
2 PLC ±0.25 [.010]			DRAWING NO	
3 PLC ±			WEIGHT	
4 PLC ±			47.5	
ANGLES ±0°30'0"			CUSTOMER DRAWING	
FINISH			SCALE	
3			1:1	
			SHEET	
			1	2
			REV	A4

THIS DRAWING IS UNPUBLISHED. RELEASED FOR PUBLICATION 20
 © COPYRIGHT20 BY TE Connectivity ALL RIGHTS RESERVED.

REVISIONS				
P	LTR	DESCRIPTION	DATE	APVD
-		SEE SHEET 1	-	-

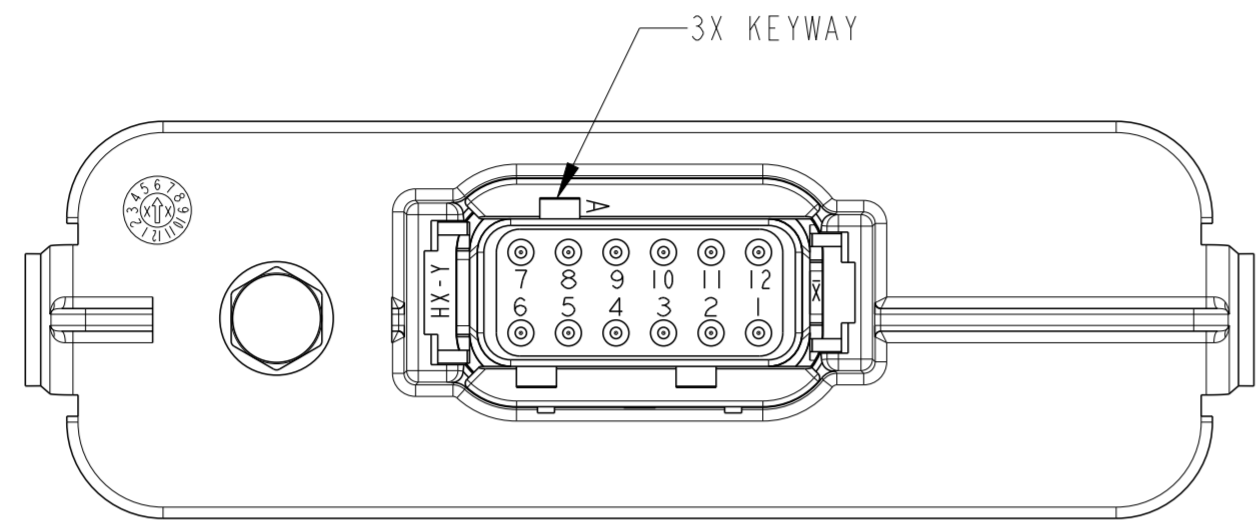

DTM13-12PA-R020
KEY -A-
SLEEVE COLOR: GREY

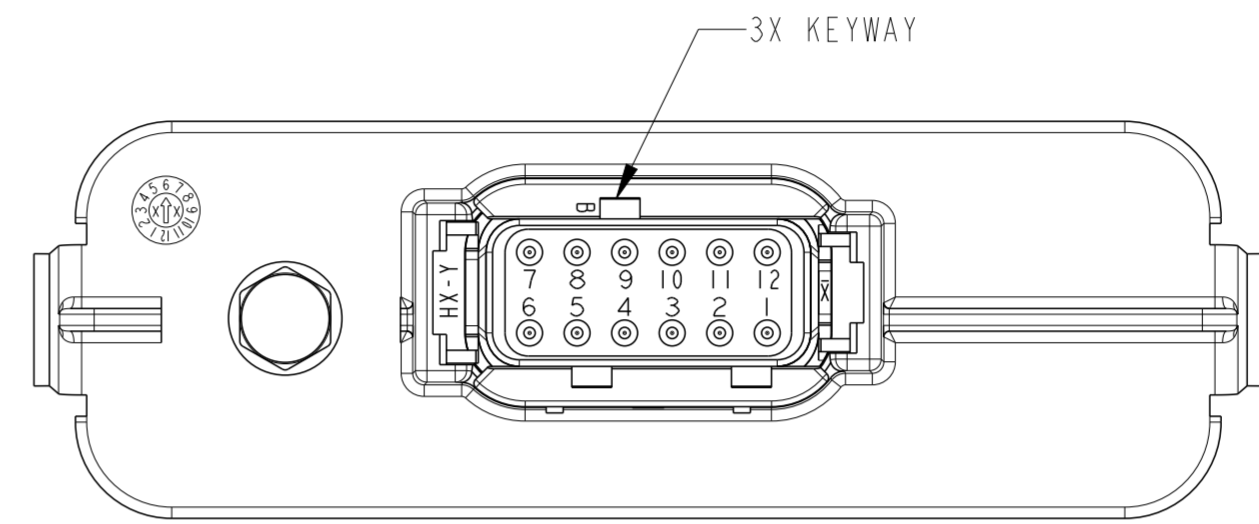

DTM13-12PB-R020
KEY -B-
SLEEVE COLOR: BLACK

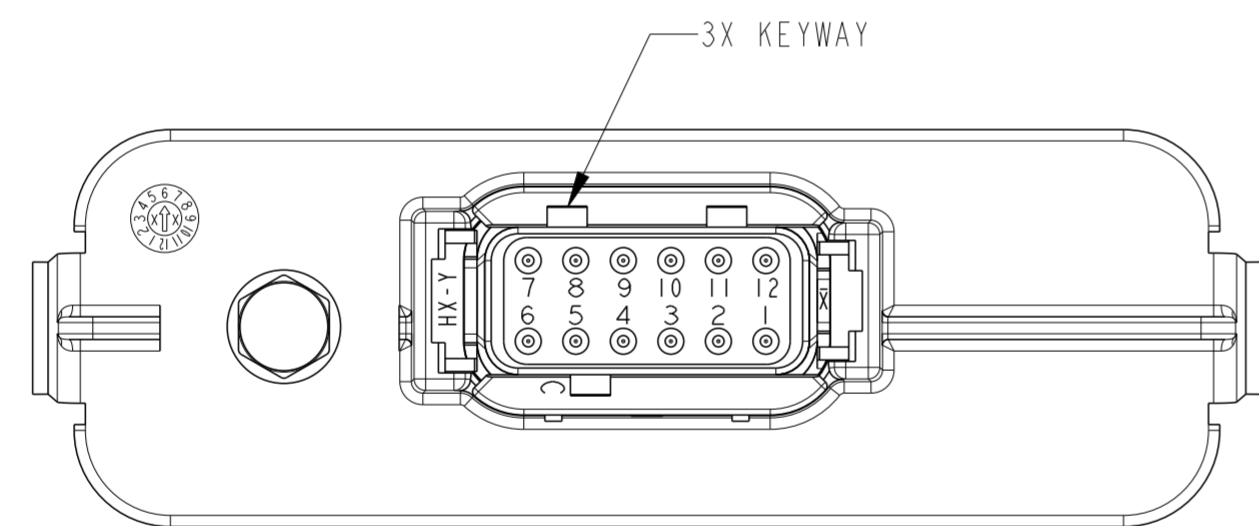

DTM13-12PC-R020
KEY -C-
SLEEVE COLOR: GREEN

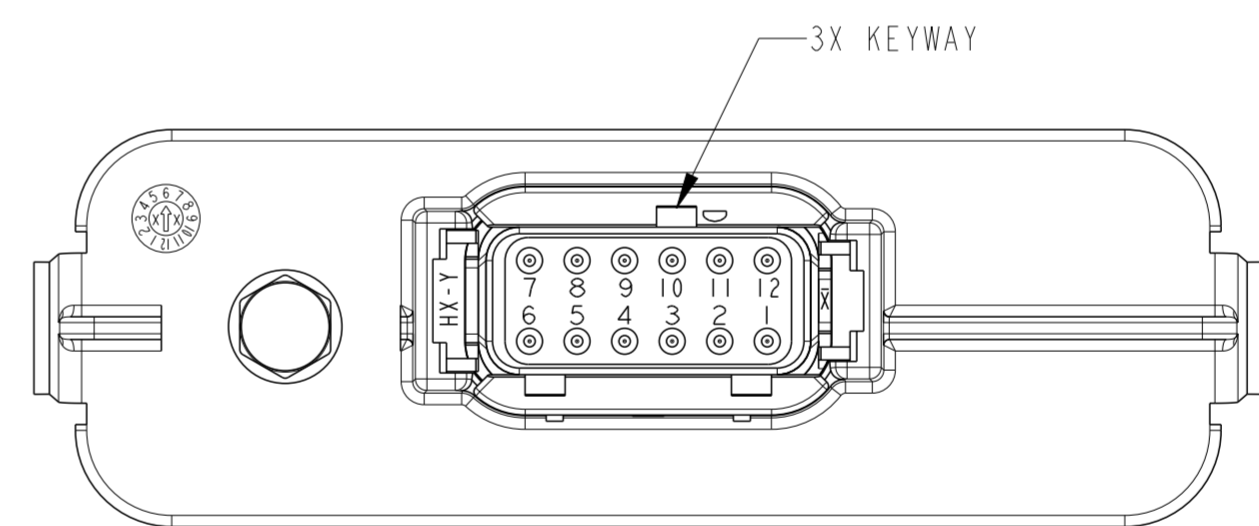

DTM13-12PD-R020
KEY -D-
SLEEVE COLOR: BROWN

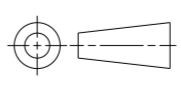
THIS DRAWING IS A CONTROLLED DOCUMENT.		DWN K. McKEE 23MAR2018	 TE Connectivity
DIMENSIONS: mm [in]		CHK K. McKEE 20AUG2018	
	TOLERANCES UNLESS OTHERWISE SPECIFIED:	APVD D. MEYER 20AUG2018	NAME RECEPTACLE HEADER 12 POS, #20 SIZE CONTACT R020 MOD, DTM SERIES
	0 PLC ±	PRODUCT SPEC	
	1 PLC ±	APPLICATION SPEC	SIZE
	2 PLC ±0.25 [0.010]		CAGE CODE
	3 PLC ±	WEIGHT 47.5	DRAWING NO
	4 PLC ±	CUSTOMER DRAWING	RESTRICTED TO
	ANGLES ±0°30'0"		A2 4AFU8
	FINISH -		SCALE 1:1
			SHEET 2 OF 2
			REV A4