

W12M-

SWITCH FUNCTION CODE	SWITCH FUNCTION DESCRIPTION
A	MOMENTARY,WIRELEADS
B	MAINTAIN,WIRELEADS
E	MOMENTARY,SOLDER TERMINAL
F	MAINTAIN,SOLDER TERMINAL
G	MOMENTARY,P.C. TERMINAL
H	MAINTAIN,P.C. TERMINAL

HOUSING MATERIAL CODE	HOUSING DECSRIPTION
1	STAINLESS STEEL, NATURAL
2	ZINC ALLOY,VELOUR CHROME PLATED
K	ALUMINUM ANODIZED BLACK
R	ALUMINUM ANODIZED RED
S	ALUMINUM, ANODIZED SILVER

BUTTON COLOR CODE	BUTTON COLOR DESCRIPTION
1	STAINLESS STEEL, NATURAL

BUTTON TYPE CODE	BUTTON TYPE DESCRIPTION
2	FLAT BUTTON ,RING (ONLY FOR MOMENTARY)
H	RAISED BUTTON ,RING

LED COLOR CODE	LED COLOR
N	NONE
R	RED
A	AMBER
Y	YELLOW
B	BLUE
G	GREEN
W	WHITE
RB	RED/BLUE
RG	RED/GREEN

LED INLET VOLTAGE CODE	LED INLET VOLTAGE	
NON-WIRELEADS	IF BLANK	FOLLOW LED SPECIFICATION
	05	5V (SEE NOTE 4)
WIRELEADS	IF BLANK	FOLLOW LED SPECIFICATION
	05	5V(SEE NOTE 4)
	12	12V
	24	24V

MECHANICAL CHARACTERISTICS:

SWITCH CIRCUITRY: SPST-NO-DB (CONTACT FORM X)
 SWITCH ACTION: MOMENTARY/MAINTAINED (PER CHART)
 BUTTON TRAVEL: 2.4mm [.094 INCH]NOMINAL
 OPERATING FORCE: 2N [204g] NOMINAL
 PANEL THICKNESS: 1.0 - 6.0mm [.039 - .236]
 SWITCH CONTACTS: GOLD PLATED
 NUT TORQUE FORCE: MAX 6 kgf-cm [5.2 LB-in]

ENVIROMENTAL SPECIFICATIONS:

ACTUATOR INGRESS PROTECTION: IP67
 OPERATING TEMPERATURE:
 MOMENTARY: -40°C to +85°C [-40°F to +185°F]
 MAINTAINED : -40°C to +65°C [-40°F to +149°F]

ELECTRICAL LIFE:

MOMENTARY:10mA@12VDC, 1,000K CYCLES NOMINAL
 MAINTAINED :10mA@12VDC, 50K CYCLES NOMINAL

ELECTRICAL SPECIFICATIONS:

DIELECTRIC STRENGTH: 1,000VAC
 INSULATION RESISTANCE: 1G OHM
 CONTACT RESISTANCE:
 50m/250m OHMS MAX INITIAL(NON-WIRELEADS/WIRELEADS)

LED SPECIFICATIONS:

SEE LED SPECIFICATION

NOTE

- CURRENT LIMITING RESISTOR IS REQUIRED TO LIMIT LED FORWARD CURRENT TO 20mA.
- SUPPLY HEX NUT AND SEALING WASHER ARE BULK PACKED.
- ONLY ZINC ALLOY HOUSING TYPE HAVE FLAT SIDE.
- INNER RESISTOR ONLY FOR LED :RED / BLUE / GREEN / WHITE

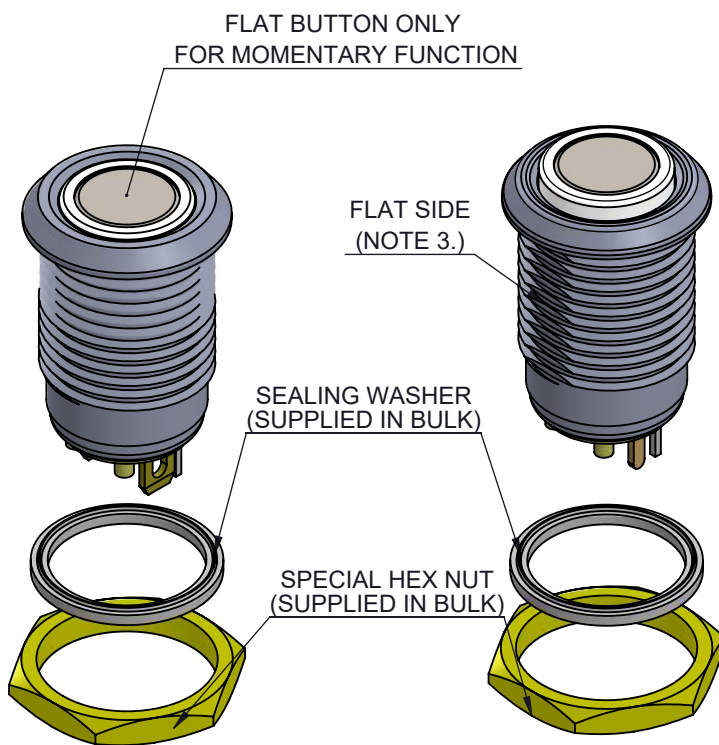

LED SPECIFICATION					
LED CODE	LED SINGLE COLOR	Vf(VDC)	If (mA)	CIRCUITRY	
		TYP.			
R	RED	2.0	20		
A	AMBER	2.0	20		
Y	YELLOW	2.0	20		
G	GREEN	3.0	20		
B	BLUE	3.1	20		
W	WHITE	3.3	20		
LED CODE	BICOLOR LED		Vf(VDC)	If (mA)	CIRCUITRY
	COLOR1	COLOR2	TYP.		
RB	RED	BLUE	2.0(RED) 3.3(BLUE)	20	
RG	RED	GREEN	2.0(RED) 3.4(GREEN)	20	

Notes:
 Hand Soldering Temperature (4mm above from Body) : 320°C for 3 seconds

WIRELEADS SPECIFICATION					
WIRELEADS TYPE	WIRELEADS SPECIFICATION	SW TERMINAL		LED	
		/	O	+	-
ILLUMINATION	AWG26 / UL1007	BLUE	BLUE	RED	BLACK
NON-ILLUMINATION		BLUE	BLUE	--	--

DWG TYPE SALES DRAWING	DRAWN <i>K.Y.</i>	TOLERANCES: UNLESS OTHERWISE NOTED X.X ± 0.5 X.XX ± 0.2 ANGULAR ± 1°	DWG TITLE W12M-MECHANICAL MOMENTARY/MAINTAINED, SOLD./P.C. TERMINAL, WIRELEADS, RING ILLUMINATION								
STATUS RELEASE	REVIEW		DWG NO. W12M-A,B,E,F,G,H								
<small>This document is the intellectual property of ITW Electronic Business Asia Co., Limited and may contain confidential, proprietary, privileged information protected by law. Neither this document nor any information it contains can be reproduced, transformed to any other format, or distributed, without written permission by ITW Electronic Business Asia Co., Limited. 本文件為安達維百電股份有限公司之智慧財產，非經許可不得翻取、複製、轉變成其他形式使用或散佈</small>			APPROVED <i>v.w.</i>	THIRD ANGLE PROJECTION 	REF: ---	<input checked="" type="checkbox"/> 管制文件 <input type="checkbox"/> 非管制文件	Unit mm	SCALE 2:1	REV 5	RoHS Compliant	SHEET 1 OF 3

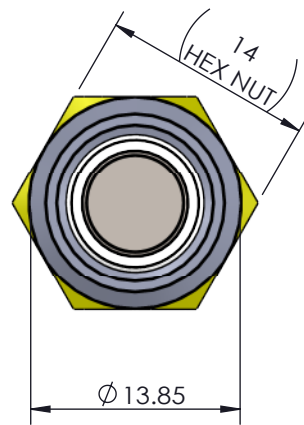

(1.3)
SEALING WASHER

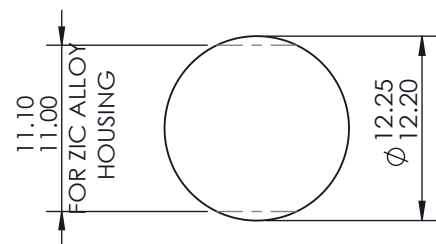
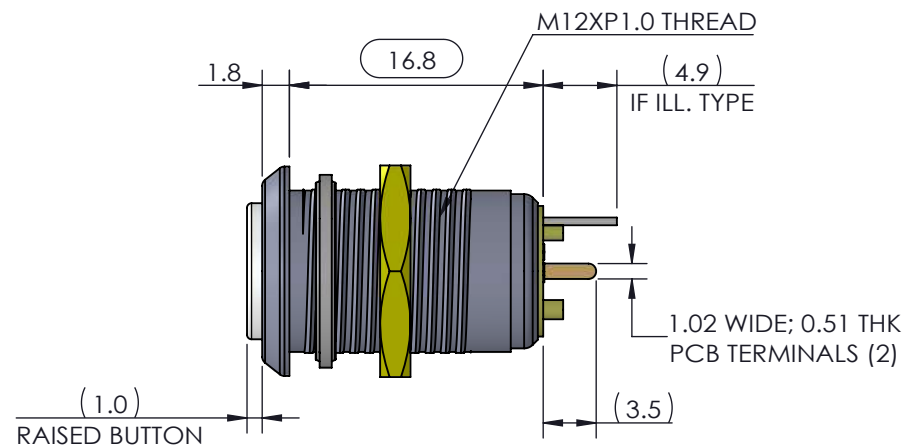
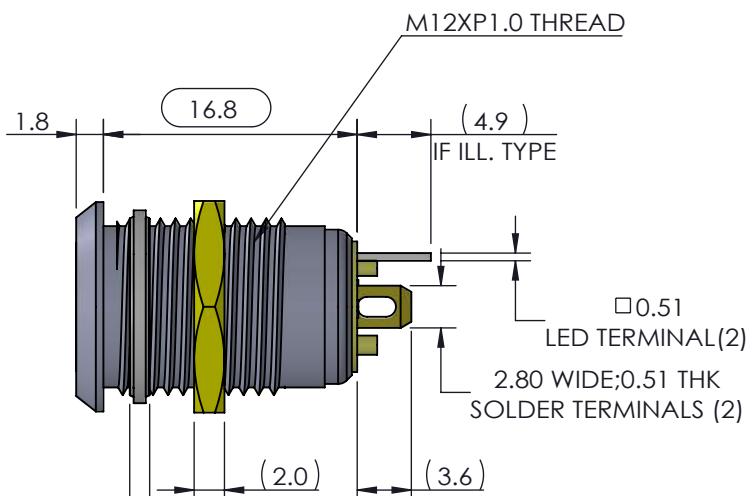

**RECOMMENDED
PANEL CUT-OUT**

**NONE ILLUMINATION
WIRELEADS**

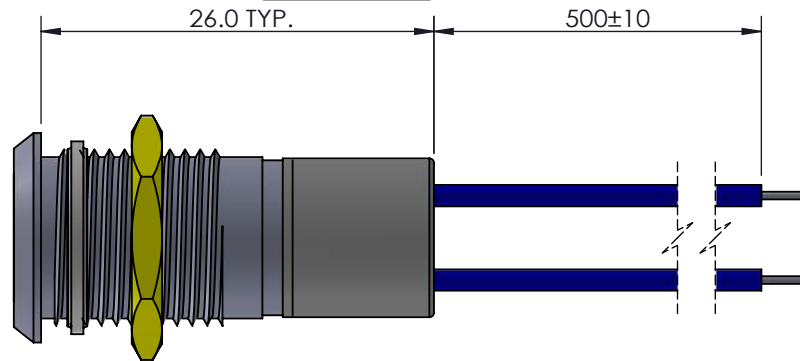

**ILLUMINATION
WIRELEADS**

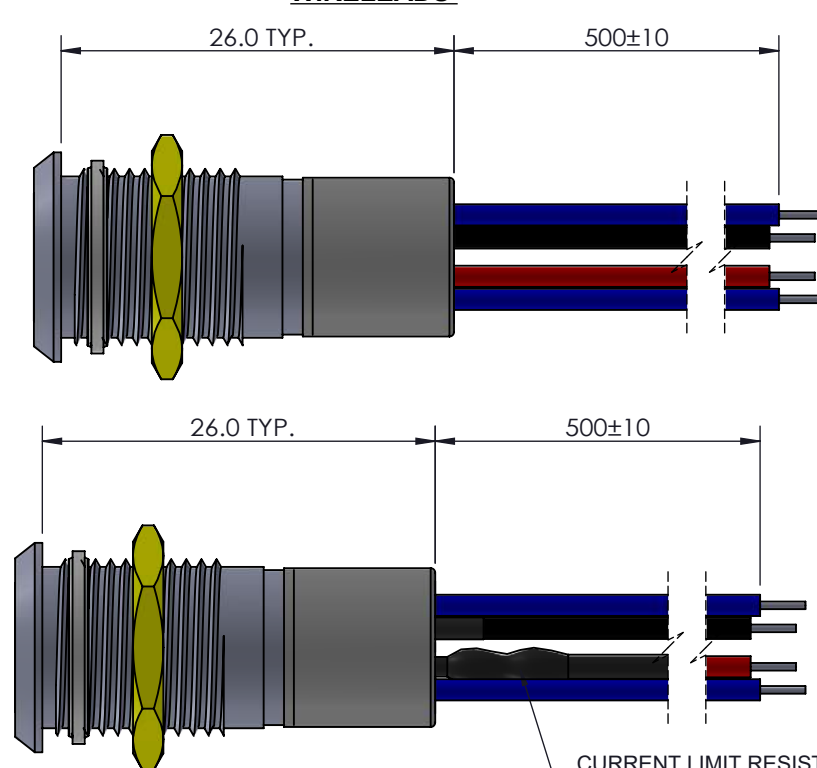

CURRENT LIMIT RESISTOR ONLY FOR:
1.5 VDC REQUIRES ONE EXTERNAL
RESISTOR: A/Y/RB/RG LED SUPPLY
2. 12 VDC, 24 VDC LED SUPPLY

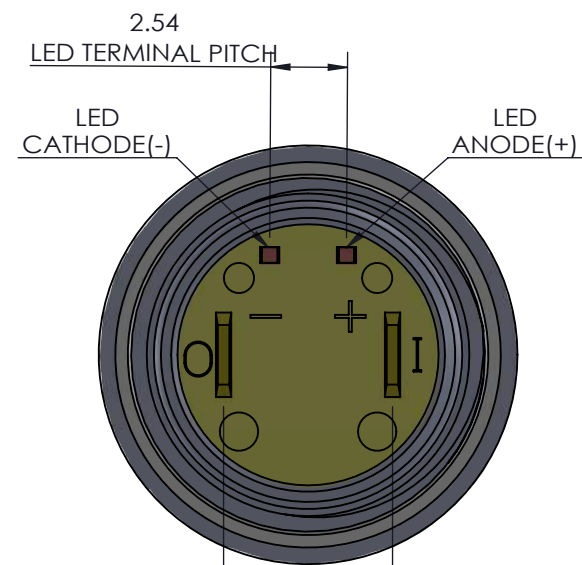

(5.6)
S/W TERMINAL PITCH
**DETAIL FOR TERMINAL POSITION
SCALE 4:1**

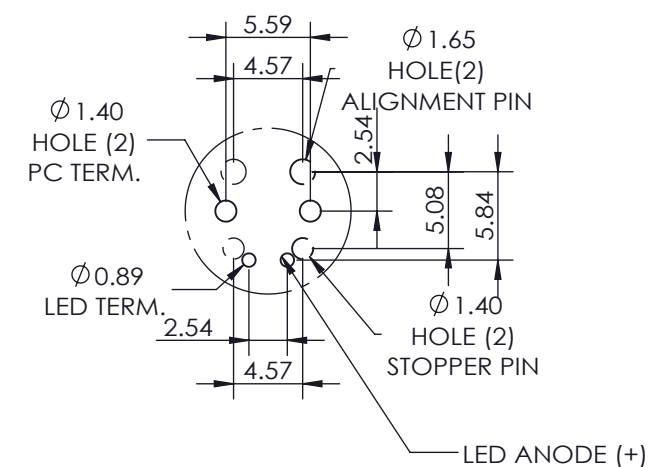

**RECOMMENDED P.C. BOARD HOLE PATTERN
(FOR PC TERMINAL)
COMPONENT SIDE**

DWG TYPE SALES DRAWING	DRAWN <i>K.Y.</i>	TOLERANCES: UNLESS OTHERWISE NOTED X.X ± 0.5 X.XX ± 0.2 ANGULAR ± 1°	DWG TITLE W12M-MECHANICAL MOMENTARY/MAINTAINED, SOLD./P.C. TERMINAL, WIRELEADS, RING ILLUMINATION							
STATUS RELEASE	REVIEW	THIRD ANGLE PROJECTION 	DWG NO. W12M-A,B,E,F,G,H							
<small>This document is the intellectual property of ITW Electronic Business Asia Co., Limited and may contain confidential, proprietary, privileged information protected by law. Neither this document nor any information it contains can be reproduced, transformed to any other format, or distributed, without written permission by ITW Electronic Business Asia Co., Limited. 本文件為安達維百電器股份有限公司之智慧財產，非經許可不得翻取、複製、轉變成其他形式使用或散佈。</small>			DATE 2017/12/29	REF: ---	<input checked="" type="checkbox"/> 管制文件 <input type="checkbox"/> 非管制文件	Unit mm	SCALE 2:1	REV 5	RoHS Compliant	SHEET 2 OF 3