

ROHM Motor Driver IC Solutions

Evaluation Board: H-Bridge Motor Drivers For DC Brush Motors



BD6212FP, BD6222FP, BD6232FP (2A / 5.5V, 15V, 32V)

No.0000000012

●Introduction

This application note will provide the steps necessary to operate and evaluate ROHM's H-Bridge motor drivers using the BD62x2 evaluation board. DC brush motors are increasingly required for a broad range of applications. DC brush motor is preferred due to their simplicity, reliability and low cost. H-bridge driver ICs control the motor's direction, speed, braking and idling.

●Description

This evaluation board has been developed for ROHM's H-Bridge driver customers evaluating the BD62x2FP series. The BD62x2FP series can operate across a wide range of power supply voltages (from 3V to 32V max), supporting output currents of up to 2A. PWM signal control (20 kHz-100 kHz) or VREF control modes are used to vary motor rotation speeds. ROHM's ICs are complete with over current protection (OCP), over voltage protection (OVP), thermal shutdown (TSD) and under voltage lock out (UVLO) protection circuits while also facilitating a low-power consumption design (10μA max). Overlap (shoot-through) protection to prevent high currents during motor reversal or braking is also built in. In addition, the devices are designed to withstand up to 4 kV ESD.

●H-Bridge Motor Driver Operation Modes

- a) Stand-by mode
- b) Forward mode
- c) Reverse mode
- d) Brake mode
- e) Forward PWM control mode
- f) Reverse PWM control mode
- g) Forward VREF control mode
- h) Reverse VREF control mode

●Applications

VCR; CD/DVD players; A/V equipment; optical disc drives; PC peripherals; car audio; car navigation systems; office automation equipment

●Evaluation Board Operating Limits and Absolute Maximum Ratings

Parameter	Symbol	Limit			Unit	Conditions
		MIN	TYP	MAX		
Supply Voltage						
	BD6212	VCC	3	-	5.5	V
	BD6222	VCC	6	-	15	V
	BD6232	VCC	6	-	32	V
VREF Voltage						
	BD6212	VREF	1.5	-	5.5	V
	BD6222	VREF	3	-	15	V
	BD6232	VREF	3	-	32	V
Electrical Characteristics						
	Max.Output Current	IOMAX	-	-	2	A
	VREF bias current	IVREF	-10	0	10	μA
	Output Carrier Frequency	FPWM	20	25	35	kHz
	Input Frequency Range	FMAX	20	-	100	kHz
	Stand-by current	ISTBY	-	0	10	μA

● Evaluation Board Schematic

Below is the evaluation board schematic with the BD62x2 as U1

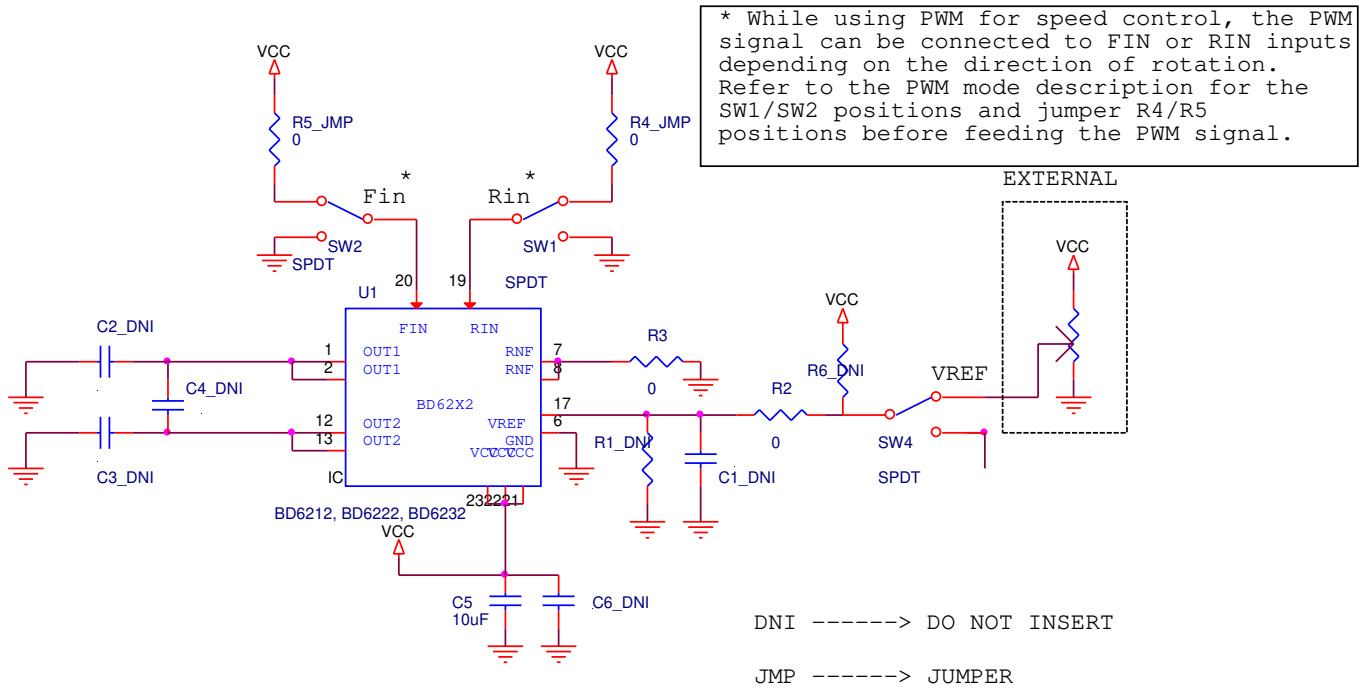

Figure 1

● Evaluation Board Labeling Scheme

Below are the labeled pictures of a populated evaluation board and the picture of an unpopulated board for reference

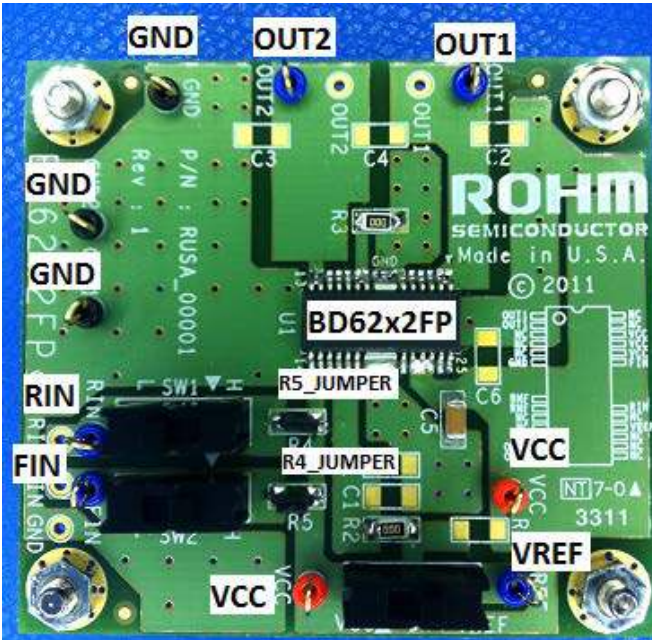

Figure 3

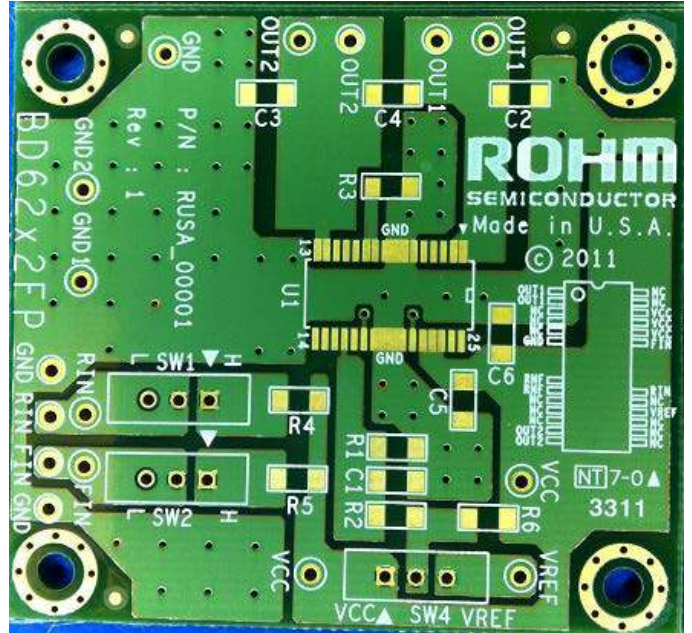

Figure 2

●Evaluation Board I/O

Below is a diagram showing the inputs (Vcc, Vref, Rin, and Fin) and outputs (Out1 and Out2) of the evaluation board.

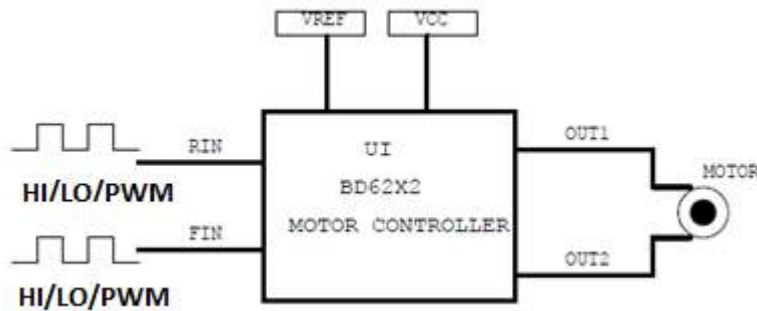

Figure 4

●Evaluation Board Operation Modes (Logic Table)

Below is a truth table describing how to obtain the different modes of operations.

	FIN	RIN	VREF	OUT1	OUT2	Operation
a	L	L	X	Hi-Z*	Hi-Z*	Stand-by (idling)
b	H	L	VCC	H	L	Forward (OUT1 > OUT2)
c	L	H	VCC	L	H	Reverse (OUT1 < OUT2)
d	H	H	X	L	L	Brake (stop)
e	PWM	L	VCC	H	PWM	Forward (PWM control)
f	L	PWM	VCC	PWM	H	Reverse (PWM control)
g	H	L	VARIABLE	H	PWM	Forward (VREF control)
h	L	H	VARIABLE	PWM	H	Reverse (VREF control)

Figure 5

●H-Bridge Motor Driver Operation Modes

The ranges of VCC and VREF will vary for different ICs as follows:

IC	VCC (V)	VREF (V)
BD6212FP	3 ~ 5.5	1.5 ~ 5.5
BD6222FP	6 ~ 15	3 ~ 15
BD6232FP	6 ~ 32	3 ~ 32

I. Stand-by mode

- Both FIN and RIN are set to a low state (<0.8V) and the output is independent of VREF in this state
- In stand-by mode all the internal circuits are turned off and the output goes to high impedance state.

II. Forward mode

- VREF is connected to VCC. FIN is a high input (>2V) and RIN is a low input (<0.8V) and are selected through SW2 and SW1 respectively.
- In the forward mode the OUT1 pin is high and OUT2 pin is low and the motor which is connected between OUT1 and OUT2 rotates in the forward (clockwise) direction.

III. Reverse mode

- VREF is connected to VCC. FIN is a low input (<0.8) and RIN is a high input (>2V) and are selected through SW2 and SW1 respectively.
- In the reverse mode the OUT1 pin is low and OUT2 pin is high and the motor which is connected between OUT1 and OUT2 rotates in the reverse (anti-clockwise) direction.

IV. Brake mode

- Both FIN and RIN are set to a high state (>2V) and the output is independent of VREF in this state
- In brake mode all the internal circuits are still operating and this mode is used to quickly stop the motor. The power consumption in this mode is greater than the stand-by mode.

V. Forward PWM control mode

- a) VREF is connected to VCC and RIN is a low input (<0.8V), selected through SW1. R5 is disconnected by opening the jumper connection, SW2 is set to H position and a PWM signal with a frequency range between 20-100kHz with an amplitude range same as that of VCC is given to FIN.
- b) The speed of the motor can be controlled by varying the duty cycle of the input PWM signal. OUT1 pin is high and OUT2 pin toggles between low and high impedance states. The motor which is connected between OUT1 and OUT2 rotates in the forward (clockwise) direction. A path for the recovery current from the motor is established by the 10µF bypass capacitor connected between VCC and GND as shown in Figure 1.

VI. Reverse PWM control mode

- a) VREF is connected to VCC and FIN is a low input (<0.8V), selected through SW2. R4 is disconnected by opening the jumper connection, SW1 is set to H position and a PWM signal with a frequency range between 20-100kHz with an amplitude range same as that of VCC is given to RIN.
- b) The speed of the motor can be controlled by varying the duty cycle of the input PWM signal. OUT2 pin is high and OUT1 pin toggles between low and high impedance states. The motor which is connected between OUT1 and OUT2 rotates in the reverse (anti-clockwise) direction. A path for the recovery current from the motor is established by the 10µF bypass capacitor connected between VCC and GND as shown in Figure 1.

VII. Forward VREF control mode

- a) FIN is a high input (>2V) and RIN is a low input (<0.8V) and are selected through SW2 and SW1 respectively. The speed of the motor can be controlled by the VREF voltage given through a potentiometer connection varying between VCC and ground as shown in the schematic.
- b) OUT1 pin is high and OUT2 pin toggles between the low and high and the motor which is connected between OUT1 and OUT2 rotates in the forward (clockwise) direction. The duty conversion circuit provides the switching duty corresponding to the voltage levels of the VREF and VCC pins.
- c) The on duty is represented by the following equation in this mode,

$$\text{On Duty} = \frac{VREF (V)}{VCC (V)}$$

- d) The switching on duty is limited by the range of VREF pin voltage. The PWM output carrier frequency in this mode is 25kHz (nominal). A path for the recovery current from the motor is established by the 10µF bypass capacitor connected between VCC and ground as shown in Figure 1.

VIII. Reverse VREF control mode

- a) RIN is a high input (>2V) and FIN is a low input (<0.8V) and are selected through SW1 and SW2 respectively. The speed of the motor can be controlled by the VREF voltage given through a potentiometer connection varying between VCC and ground as shown in the schematic.
- b) OUT2 pin is high and OUT1 pin toggles between the low and high and the motor which is connected between OUT1 and OUT2 rotates in the reverse (anti-clockwise) direction. The duty conversion circuit provides the switching duty corresponding to the voltage levels of the VREF and VCC pins.
- c) The on duty is represented by the following equation in this mode,

$$\text{On Duty} = \frac{VREF (V)}{VCC (V)}$$

- d) The switching on duty is limited by the range of VREF pin voltage. The PWM output carrier frequency in this mode is 25kHz (nominal). A path for the recovery current from the motor is established by the 10µF bypass capacitor connected between VCC and ground as shown in Figure 1.

● Evaluation Board Functional Test Setup

Below is the test setup used to evaluate the board for motor operation in PWM mode

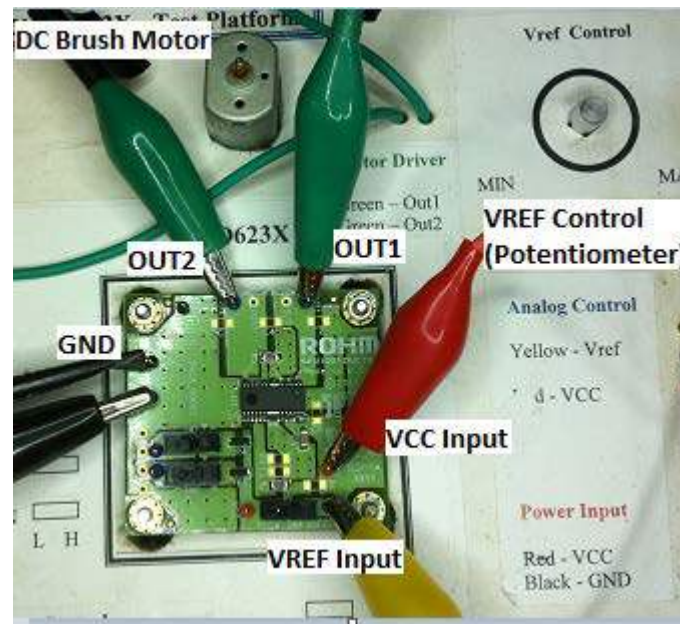

Figure 6

● Board Testing Performed

Appropriate VCC, VREF (refer to the table in the above section for the applicable ranges of VCC and VREF) and GND were connected to the board and all the modes of operation for the motor driver were tested.

- 1) VCC, VREF and GND were connected to the board.
- 2) VREF was connected to VCC to check the stand-by, forward, reverse and the brake modes. Note that the inputs given to FIN and RIN are different for each mode. The motor rotation was observed to be clockwise for the forward mode, anti-clockwise for the reverse mode and stationary for the stand-by and the brake modes.
- 3) The motor speed was varied by varying the duty cycle of the PWM signal in the PWM control mode. PWM signal was connected to either FIN or RIN depending on forward or reverse PWM control mode. Resistance R5 or R4 (jumper) were disconnected by opening the jumper when the PWM signal was given through FIN and RIN respectively through the test points. The duty cycle of the PWM signal was varied and the variation of motor rotation speed was observed.
- 4) The forward and reverse PWM control modes were tested by giving appropriate inputs to FIN and RIN (refer to Figure 5 or motor driver operation modes).
- 5) The VREF control modes were tested by varying the VREF voltage levels. FIN and RIN were connected to the appropriate inputs depending on the forward or reverse operation (refer to Figure 5 or motor driver operation modes).
- 6) Variation in the speed of the motor rotation was observed when the VREF voltage was varied.

● Evaluation Board BOM

Below is a table with the build of materials. Part numbers for Digikey have been provided for reference.

Part Type	Symbol	Qty/board	DigiKey Description	Digikey #
Res 0 ohm, 2512	R2, R3	2	RES 0.0 OHM 1/4W 1206	RHM0.0
Cap 10uF, 1206	C5	1	CAP CER 10UF 50V X5R 20% 1206	445-5999-1-ND
Jumpers	R4, R5	2	CONN JUMPER SHORTING 1.27MM GOLD	S9346-ND
Switches	SW1, SW2, SW4	3	SWITCH SLIDE SPDT 30V.2A PC MNT	EG1903-ND
Test point Red	TP1, TP8	2	TEST POINT PC MINI .040"D RED	5000K-ND
Test point Black	TP2, TP9, TP10	3	TEST POINT PC MINI .040"D BLACK	5001K-ND
Test point Blue	TP3, TP4, TP5, TP6, TP7	5	TEST POINT PC MINIATURE T/H BLUE	5117K-ND
Motor Driver	U1	1	IC H-BRIDGE DRIVER 1CH 2A HSOP25	BD62x2FP-E2TR-ND

● Notes for use

- 1) The voltage levels for VCC and VREF vary with the chip used (BD6212FP, BD6222FP and BD6232FP). The range PWM input is same as that of the VCC for each chip.
- 2) Test points for VCC, VREF, GND, FIN, RIN, OUT1 and OUT2 are provided on the board and the signals can be connected to these test points for convenience.
- 3) SW4 which is a switch connecting the VREF voltage to the chip through the R2 resistor needs to be in the same position for all modes.
- 4) SW1 is used to select the high or low input to RIN depending on the mode (refer to Figure 5 and the motor driver operation modes section). In the PWM mode, when the PWM input is to be given to RIN the R4 jumper is opened and the SW1 is put to H position. PWM input is given to the RIN test point.
- 5) SW2 is used to select the high or low input to FIN depending on the mode (refer to Figure 5 and the motor driver operation modes section). In the PWM mode, when the PWM input is to be given to FIN the R5 jumper is opened and the SW2 is put to H position. PWM input is given to the RIN test point.
- 6) The resistors R4 and R5 are connected through jumpers in all modes except PWM control modes. In the PWM mode, a resistor R4 or R5 is removed by opening the jumper at the respective position depending on the forward or reverse control operation.
- 7) Connecting the power supply in reverse polarity can damage the IC. Take precautions against the reverse polarity when connecting the power supply lines, such as adding an external direction diode.
- 8) Return current generated by the motor's Back-EMF requires counter-measures, such as providing a return current path by inserting capacitors across the power supply and GND (10µF ceramic capacitor is recommended). In this case, it is important to confirm that none of the negative effects sometimes seen with electrolytic capacitors – including a capacitance drop at low temperatures – occurs. Also, the connected power supply must have sufficient current absorbing capability. Otherwise, the regenerated current will increase voltage on the power supply line, which may in turn cause problems with the product, including peripheral circuits exceeding the absolute maximum rating. To help protect against damage or degradation, physical safety measures should be take, such as providing voltage clamping diode across the power supply and GND.
- 9) Strong electromagnetic fields may cause IC malfunctions. Use extreme caution with electromagnetic fields.
- 10) The thermal shutdown (TSD) circuit in the IC is designed to shut the IC off to prevent thermal runaway. It is not designed to protect the IC or guarantee its operation in the presence of extreme heat. Do not continue to use the IC after the TSD circuit is activated, and do not operate the IC in an environment where the activation of the circuit is assumed.

- 11) In case a large capacitor is connected between output and GND, if VCC and VIN are short-circuited with 0V or GND for any reason, the current charged in the capacitor flows into the output and may destroy the IC. Use a capacitor smaller than 1 μ F between output and GND.
- 12) Connecting a capacitor at low impedance pin subjects the IC to stress. Therefore, always discharge capacitors after each process or step. Always turn the IC's power supply off before connecting it to or removing it from the test setup during the inspection process. Ground the IC during assembly steps as an antistatic measure. Use similar precaution when transporting or storing the IC.
- 13) When the operation mode is in PWM control or VREF control, PWM switching noise may affect the control input pins and cause IC malfunctions. In this case, insert a pull down resistor (10k Ω is recommended) between each control input pin and ground.

Notes

No copying or reproduction of this document, in part or in whole, is permitted without the consent of ROHM Co.,Ltd.

The content specified herein is subject to change for improvement without notice.

The content specified herein is for the purpose of introducing ROHM's products (hereinafter "Products"). If you wish to use any such Product, please be sure to refer to the specifications, which can be obtained from ROHM upon request.

Examples of application circuits, circuit constants and any other information contained herein illustrate the standard usage and operations of the Products. The peripheral conditions must be taken into account when designing circuits for mass production.

Great care was taken in ensuring the accuracy of the information specified in this document. However, should you incur any damage arising from any inaccuracy or misprint of such information, ROHM shall bear no responsibility for such damage.

The technical information specified herein is intended only to show the typical functions of and examples of application circuits for the Products. ROHM does not grant you, explicitly or implicitly, any license to use or exercise intellectual property or other rights held by ROHM and other parties. ROHM shall bear no responsibility whatsoever for any dispute arising from the use of such technical information.

The Products specified in this document are intended to be used with general-use electronic equipment or devices (such as audio visual equipment, office-automation equipment, communication devices, electronic appliances and amusement devices).

The Products specified in this document are not designed to be radiation tolerant.

While ROHM always makes efforts to enhance the quality and reliability of its Products, a Product may fail or malfunction for a variety of reasons.

Please be sure to implement in your equipment using the Products safety measures to guard against the possibility of physical injury, fire or any other damage caused in the event of the failure of any Product, such as derating, redundancy, fire control and fail-safe designs. ROHM shall bear no responsibility whatsoever for your use of any Product outside of the prescribed scope or not in accordance with the instruction manual.

The Products are not designed or manufactured to be used with any equipment, device or system which requires an extremely high level of reliability the failure or malfunction of which may result in a direct threat to human life or create a risk of human injury (such as a medical instrument, transportation equipment, aerospace machinery, nuclear-reactor controller, fuel-controller or other safety device). ROHM shall bear no responsibility in any way for use of any of the Products for the above special purposes. If a Product is intended to be used for any such special purpose, please contact a ROHM sales representative before purchasing.

If you intend to export or ship overseas any Product or technology specified herein that may be controlled under the Foreign Exchange and the Foreign Trade Law, you will be required to obtain a license or permit under the Law.



Thank you for your accessing to ROHM product informations.
More detail product informations and catalogs are available, please contact us.

ROHM Customer Support System

<http://www.rohm.com/contact/>