

MATED DIMENSIONS
(FOR ALIGNMENT OF PCB'S IN X & Y DIRECTIONS)

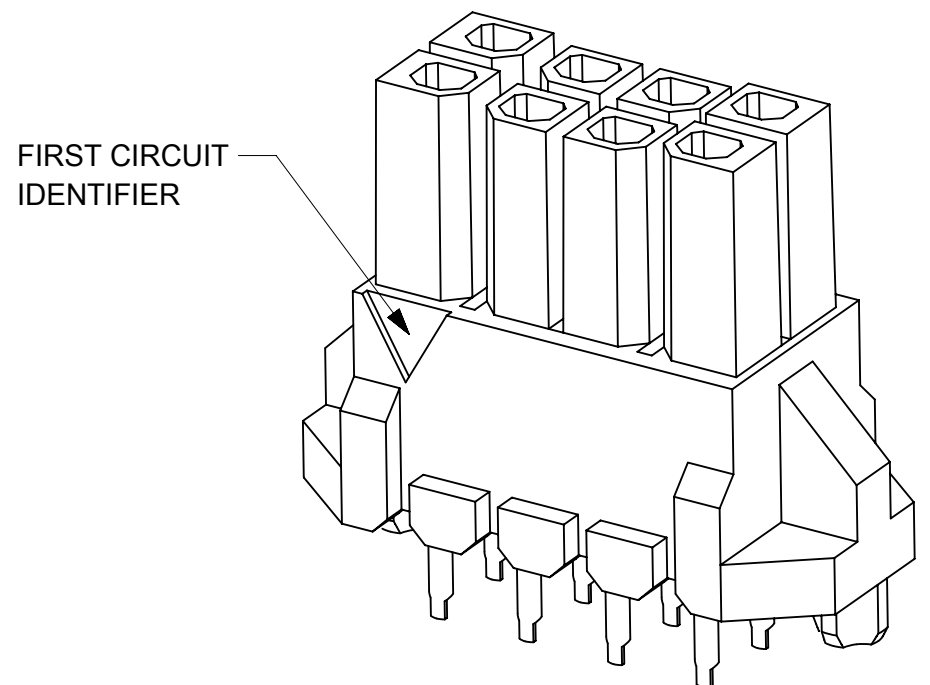
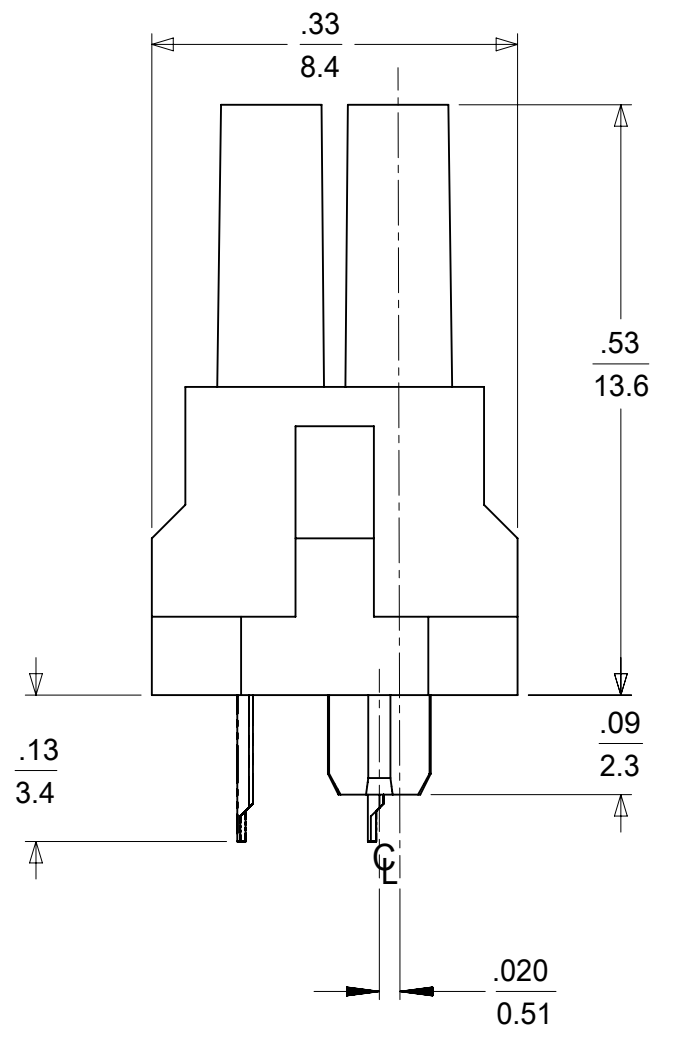
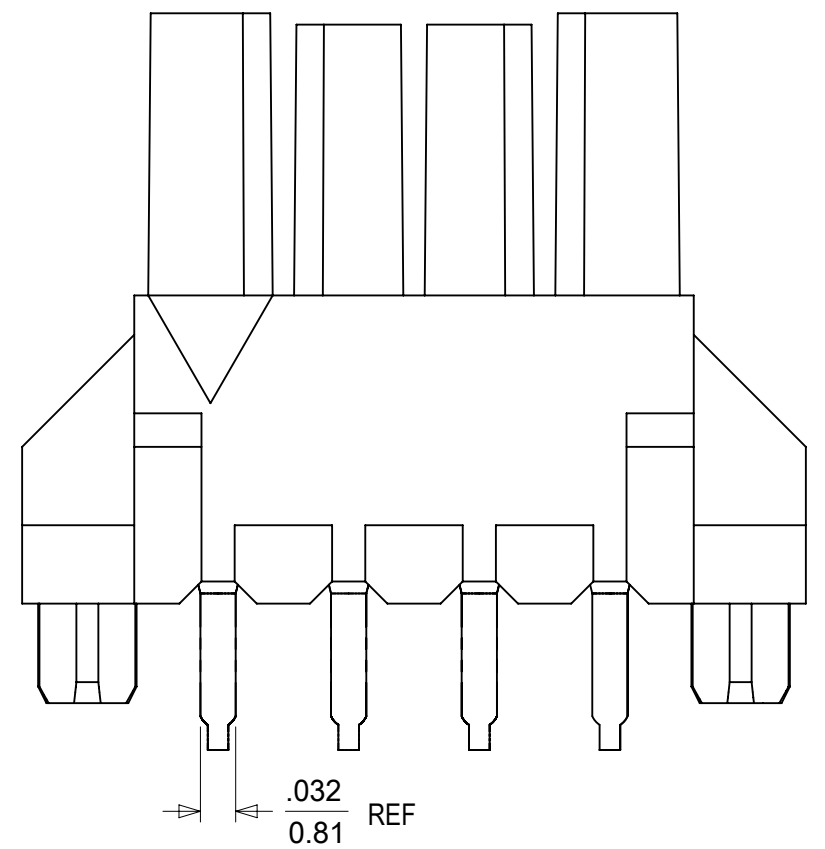

CIRCUIT SIZE	DIM. "A"	DIM. "B"	DIM. "C"
4	.472/(12.00)	.118/(3.00)	.354/(9.00)
6	.591/(15.00)	.236/(6.00)	.472/(12.00)
8	.709/(18.00)	.354/(9.00)	.591/(15.00)
10	.827/(21.00)	.472/(12.00)	.709/(18.00)
12	.945/(24.00)	.591/(15.00)	.827/(21.00)
14	1.063/(27.00)	.709/(18.00)	.945/(24.00)
16	1.181/(30.00)	.827/(21.00)	1.063/(27.00)
18	1.299/(33.00)	.945/(24.00)	1.181/(30.00)
20	1.417/(36.00)	1.063/(27.00)	1.299/(33.00)
22	1.535/(39.00)	1.181/(30.00)	1.417/(36.00)
24	1.654/(42.00)	1.299/(33.00)	1.535/(39.00)

- NOTES:
- MATERIAL:
HOUSING: LIQUID CRYSTAL POLYMER, GLASS FILLED, UL 94V-0, COLOR - BLACK
TERMINALS: PHOSPHOR BRONZE ALLOY
 - FINISH:
(A) = .000100/0.00254 MIN. TIN OVER
.000050/0.00127 MIN. NICKEL
(B) = .000015/0.00038 MIN. SELECTIVE GOLD IN CONTACT AREA,
.000100/0.00254 MIN. SELECTIVE TIN IN PC TAIL AREA,
BOTH OVER .000050/0.00127 MIN. NICKEL
(C) = .000030/0.00076 MIN. SELECTIVE GOLD IN CONTACT AREA,
.000100/0.00254 MIN. SELECTIVE TIN IN PC TAIL AREA,
BOTH OVER .000050/0.00127 MIN. NICKEL
 - PRODUCT SPECIFICATIONS: PS-44300-001
 - PACKAGING SPECIFICATION: PK-44769-001.
 - THIS HEADER MATES WITH MOLEX MICRO-FIT BMI HEADER SERIES 45280, 44432, AND 44428, AND MOLEX MICRO-FIT BMI PLUG SERIES 44300.
 - MOLEX RECOMMENDS THE USE OF MICRO-FIT TEST PLUG (SERIES 44242) WHENEVER CONTINUITY TESTING IS PERFORMED. TEST PLUGS MUST NOT BE USED TO MAKE OR BREAK UNDER LOAD. MOLEX DOES NOT RECOMMEND USING STANDARD MATING COMPONENTS (SERIES 45280, 44432, 44428, OR 44300) FOR TESTING PURPOSES.
 - THIS PART CONFORMS TO CLASS 'B' REQUIREMENTS OF COSMETIC SPECIFICATION PS-45499-002.

SYMBOLS		THIS DRAWING CONTAINS INFORMATION THAT IS PROPRIETARY TO MOLEX ELECTRONIC TECHNOLOGIES, LLC AND SHOULD NOT BE USED WITHOUT WRITTEN PERMISSION		CURRENT REV DESC: ADD POLARIZATION	
▽ = 0	IN/MM	SCALE	NTS		
▽ = 0	GENERAL TOLERANCES (UNLESS SPECIFIED)				
▽ = 0		MM	INCH		
▽ = 0	4 PLACES	±	±	EC NO: 611105	
▽ = 0	3 PLACES	±	± 0.01	DRWN: JBAUMERT 2019/01/25	
▽ = 0	2 PLACES	± 0.25	± 0.014	CHK'D: SSOUSEK 2019/02/05	
▽ = 0	1 PLACE	± 0.35	±	APPR: FSMITH 2019/02/07	
▽ = 0	0 PLACES	±	±	INITIAL REVISION:	
▽ = 0	ANGULAR TOL	± 0.5°		DRWN: BURLESON 2000/07/13	
▽ = 0	DRAFT WHERE APPLICABLE MUST REMAIN WITHIN DIMENSIONS		THIRD ANGLE PROJECTION	DRAWING	SERIES
▽ = 0				C-SIZE	44769

MICRO-FIT (3.0) BMI VERTICAL RECEPTACLE HEADER ASSEMBLY, 4 - 24 CIRCUIT

PRODUCT CUSTOMER DRAWING

DOCUMENT NUMBER: SD-44769-001 DOC TYPE: PSD DOC PART: 001 REVISION: F1

MATERIAL NUMBER: SEE CHART CUSTOMER: GENERAL MARKET SHEET NUMBER: 1 OF 2

POLARIZATION LAYOUT

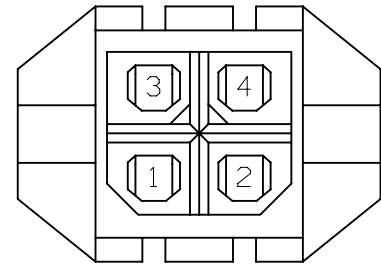

4 CIRCUIT

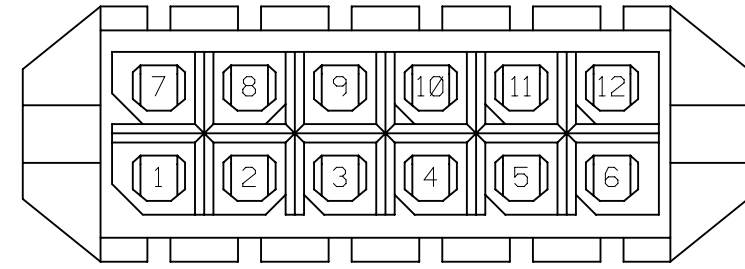

12 CIRCUIT

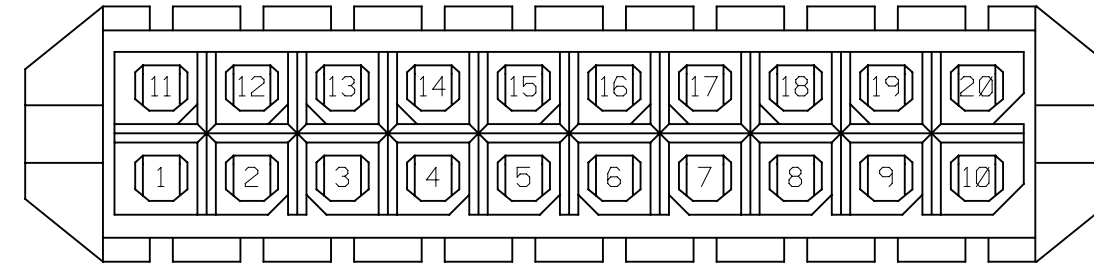

20 CIRCUIT

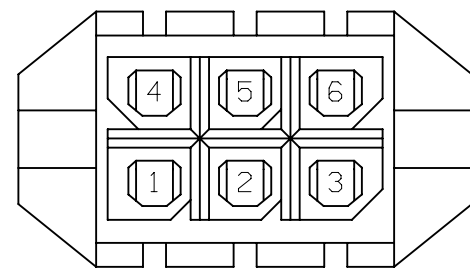

6 CIRCUIT

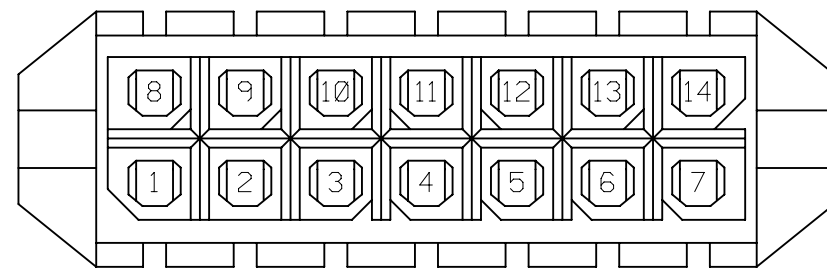

14 CIRCUIT

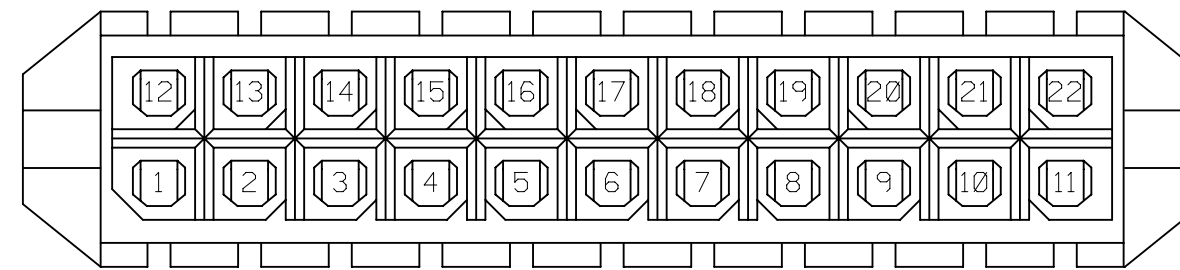

22 CIRCUIT

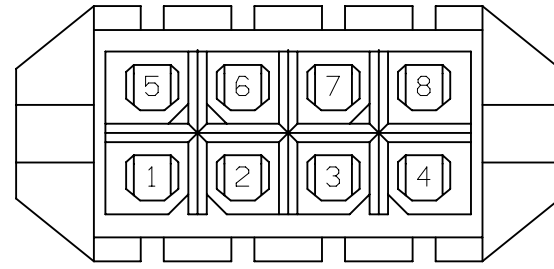

8 CIRCUIT

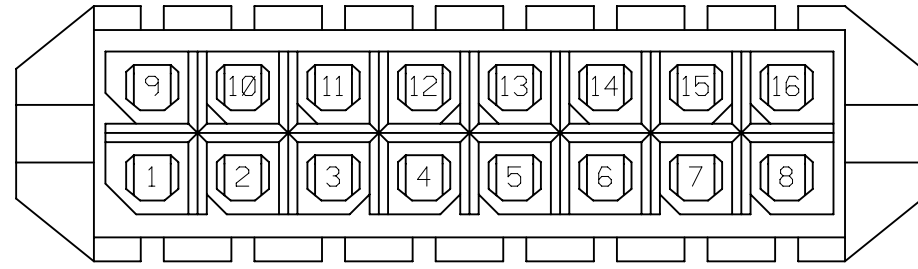

16 CIRCUIT

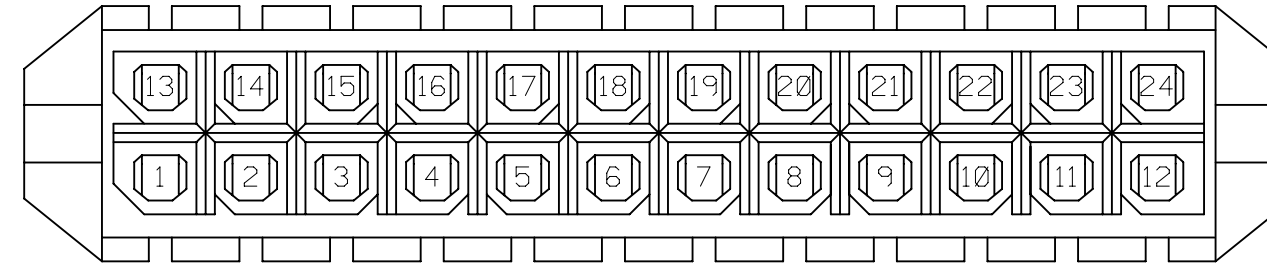

24 CIRCUIT

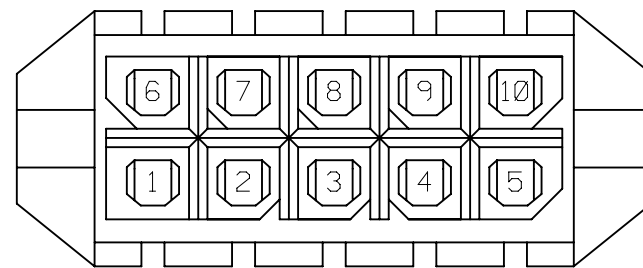

10 CIRCUIT

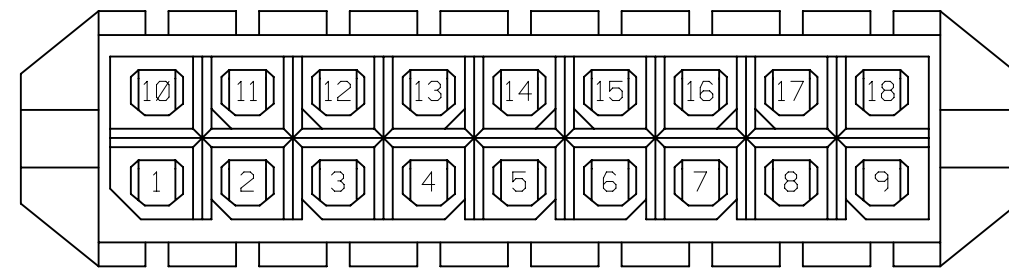

18 CIRCUIT

MATERIAL NUMBER	NUMBER OF POSITIONS	PLATING OPTION
44769-0401	04	A
44769-0402	04	B
44769-0403	04	C
44769-0601	06	A
44769-0602	06	B
44769-0603	06	C
44769-0801	08	A
44769-0802	08	B
44769-0803	08	C
44769-1001	10	A
44769-1002	10	B
44769-1003	10	C
44769-1201	12	A
44769-1202	12	B
44769-1203	12	C
44769-1401	14	A
44769-1402	14	B
44769-1403	14	C
44769-1601	16	A
44769-1602	16	B
44769-1603	16	C
44769-1801	18	A
44769-1802	18	B
44769-1803	18	C
44769-2001	20	A
44769-2002	20	B
44769-2003	20	C
44769-2201	22	A
44769-2202	22	B
44769-2203	22	C
44769-2401	24	A
44769-2402	24	B
44769-2403	24	C

SYMBOLS DIMENSION UNITS: IN/MM SCALE: NTS GENERAL TOLERANCES (UNLESS SPECIFIED): 4 PLACES ± 0.25 ± 0.014 3 PLACES ± 0.25 ± 0.014 2 PLACES ± 0.25 ± 0.014 1 PLACE ± 0.35 ± 0 PLACES ± ANGULAR TOL ± 0.5° DRAFT WHERE APPLICABLE MUST REMAIN WITHIN DIMENSIONS THIRD ANGLE PROJECTION DRAWING SERIES: C-SIZE 44769	THIS DRAWING CONTAINS INFORMATION THAT IS PROPRIETARY TO MOLEX ELECTRONIC TECHNOLOGIES, LLC AND SHOULD NOT BE USED WITHOUT WRITTEN PERMISSION CURRENT REV DESC: ADD POLARIZATION EC NO: 611105 DRWN: JBAUMERT 2019/01/25 CHK'D: SSOUSEK 2019/02/05 APPR: FSMITH 2019/02/07 INITIAL REVISION: DRWN: BURLESON 2000/07/13 APPR: EDGLEY 2000/07/13		 MICRO-FIT (3.0) BMI VERTICAL RECEPTACLE HEADER ASSEMBLY, 4 - 24 CIRCUIT PRODUCT CUSTOMER DRAWING DOCUMENT NUMBER: SD-44769-001 DOC TYPE: PSD DOC PART: 001 REVISION: F1 MATERIAL NUMBER: SEE CHART CUSTOMER: GENERAL MARKET SHEET NUMBER: 2 OF 2
	DOCUMENT STATUS: P1 RELEASE DATE: 2019/02/07 14:35:12		