

REVISIONS				
P.	LTN.	DESCRIPTION	DATE	APVD.
A		REVISED PER DG3B-0550-01	02-OCT-01	KW SR
A1		REVISED PER ECO-07-001375	18JAN2007	KW DC
A2		REV. BY ECO 17-011267	24AUG2017	HC KR
A3		REVISED PER ECR-17-014951	16OCT2017	BDA KR

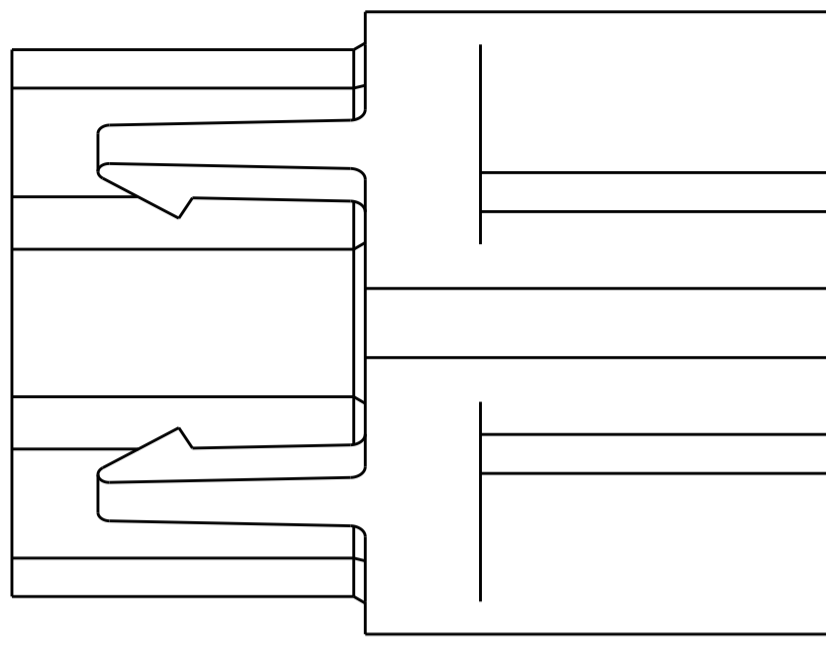

- 1 FOUR RIBS EQUALLY SPACED, NO SPECIFIC ORIENTATION.
- 2 CSA CERTIFICATION LOGO LOCATED APPROXIMATELY AS SHOWN.
- 3 DIMENSIONS SHOWN REPRESENT PRODUCT IN DRY, AS MOLDED, CONDITION. ADDITIONAL 2% GROWTH DUE TO SUBSEQUENT MOISTURE ABSORPTION MAY OCCUR AND SHOULD BE ACCOUNTED FOR.

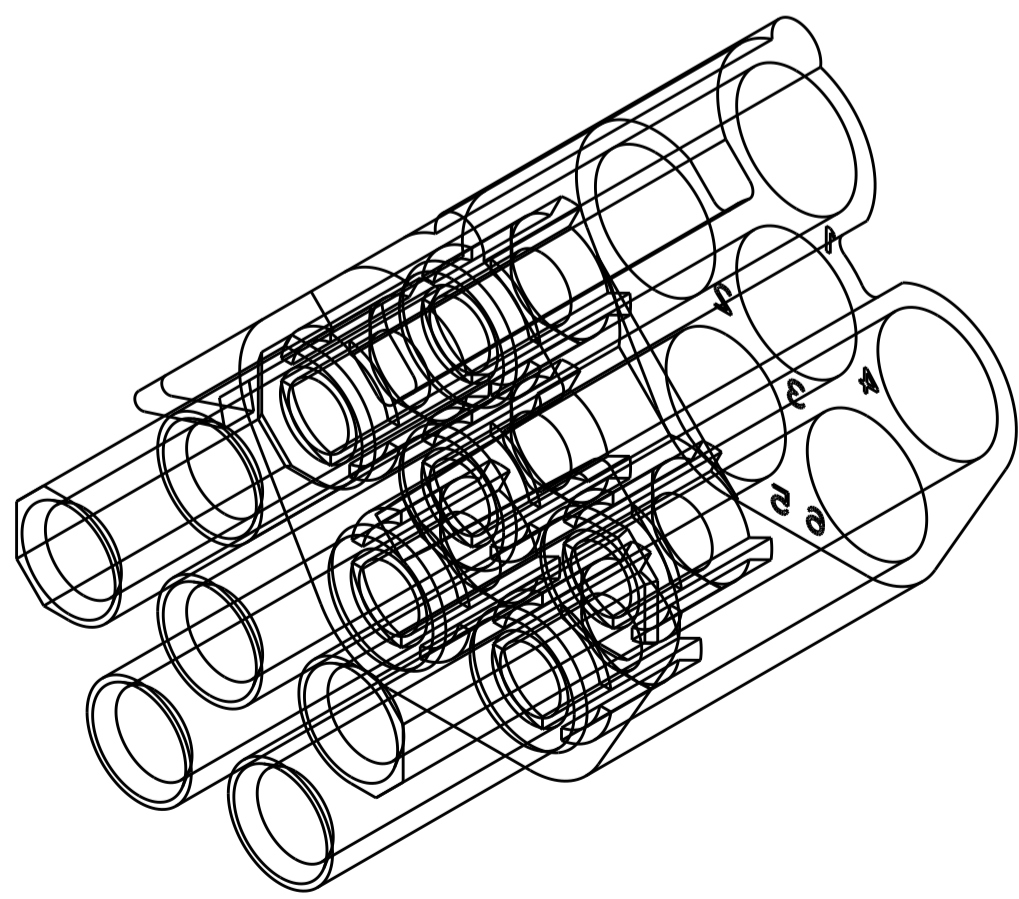
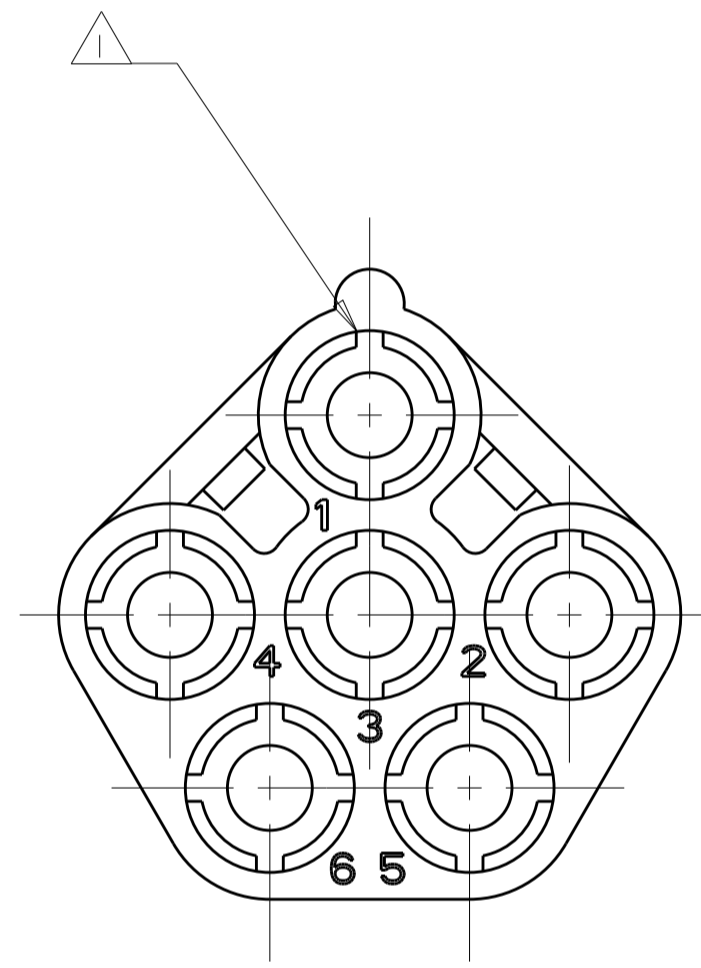
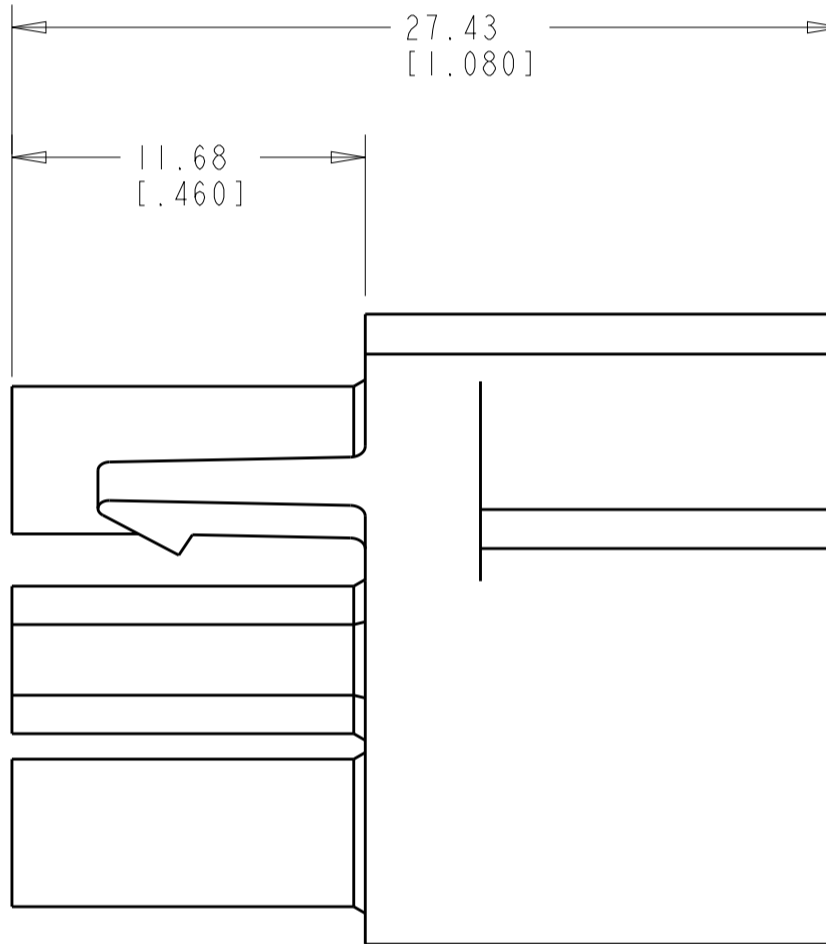
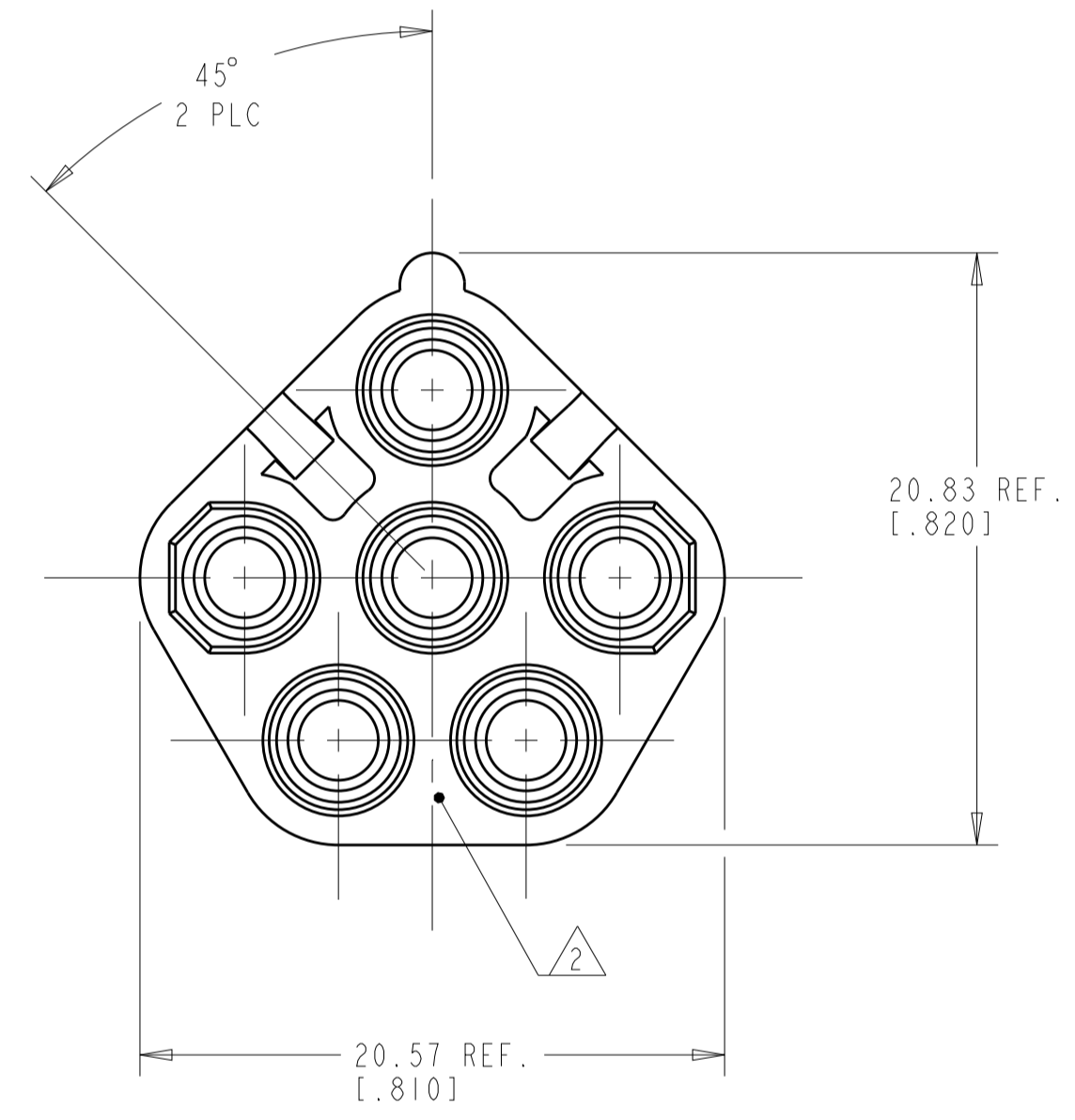

3-DIMENSIONAL MODEL
SCALE 4:1

VOLUME	COLOR	PART NUMBER
0.172 IN ³	BLACK	794911-9
0.172 IN ³	GRAY	794911-8
0.172 IN ³	BROWN	794911-7
0.172 IN ³	BLUE	794911-6
0.172 IN ³	GREEN	794911-5
0.172 IN ³	YELLOW	794911-4
0.172 IN ³	ORANGE	794911-3
0.172 IN ³	RED	794911-2
0.172 IN ³	NATURAL	794911-1

THIS DRAWING IS A CONTROLLED DOCUMENT.		DWN K. WHITAKER 23-MAR-2001	TE Connectivity NAME PLUG, CIRCULAR, 6 CIRCUIT, UNIVERSAL MATE-N-LOK(TM)	
DIMENSIONS:		CHK S. RIDGILL 23-MAR-2001		
mm	TOLERANCES UNLESS OTHERWISE SPECIFIED:	APVD S. RIDGILL 23-MAR-2001	PRODUCT SPEC	
0 PLC	±		APPLICATION SPEC	
1 PLC	±		SIZE	
2 PLC	±0.131(.005)		CAGE CODE	
3 PLC	±		DRAWING NO.	
4 PLC	±		RESTRICTED TO	
ANGLES	±		A1 00779 794911	
FINISH	±		SCALE 4:1 SHEET 1 OF 1 REV A3	
MATERIAL NYLON, UL 94V-2		WEIGHT	CUSTOMER DRAWING	