

PAGE 1/2

ISSUE 10-07-19

SERIE : SPnT

PART NUMBER : R573F83005

## RF CHARACTERISTICS

Number of ways : 10  
 Frequency range : 0 - 22 GHz  
 Impedance : 50 Ohms

Frequency (GHz)	DC - 3	3 - 8	8 - 12.4	12.4 - 15.5	15.5 - 18	18 - 22
VSWR max	1.20	1.30	1.40	1.50	1.70	1.80
Insertion loss max	0.20 dB	0.30 dB	0.40 dB	0.50 dB	0.70 dB	0.80 dB
Isolation min	80 dB	70 dB	60 dB	60 dB	55 dB	55 dB
Average power (*)	240 W	150 W	120 W	110 W	100 W	90 W

## ELECTRICAL CHARACTERISTICS

Actuator : LATCHING  
 Nominal current \*\* : 500 mA  
 Actuator voltage (Vcc) : 28V (24 to 30V) / NEGATIVE COMMON  
 Terminals : 25 pins D-SUB male connector  
 Self cut-off time : 40 ms < CT < 120 ms

## MECHANICAL CHARACTERISTICS

Connectors : SMA female per MIL-C 39012  
 Life : 2 million cycles per position  
 Switching Time\*\*\* : < 50 ms  
 Construction : Splashproof  
 Weight : < 360 g

## ENVIRONMENTAL CHARACTERISTICS

Operating temperature range : -40°C to +85°C  
 Storage temperature range : -55°C to +85°C

(\* Average power at 25°C per RF Path)

(\*\* At 25° C ±10%)

(\*\*\* Nominal voltage ; 25° C)



PAGE 2/2

ISSUE 10-07-19

SERIE : SPnT

PART NUMBER : R573F83005

**DRAWING**

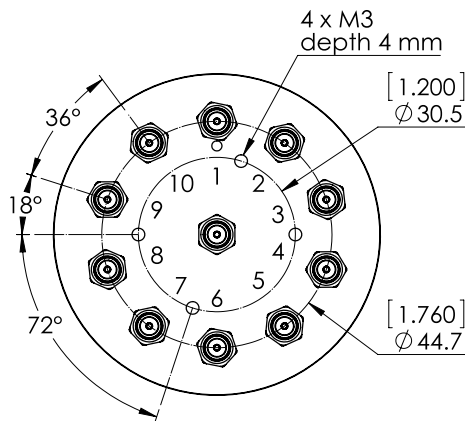

Voltage	RF Continuity
-C +1	IN ↔ 1
-C +2	IN ↔ 2
-C +3	IN ↔ 3
-C +4	IN ↔ 4
-C +5	IN ↔ 5
-C +6	IN ↔ 6
-C +7	IN ↔ 7
-C +8	IN ↔ 8
-C +9	IN ↔ 9
-C +10	IN ↔ 10

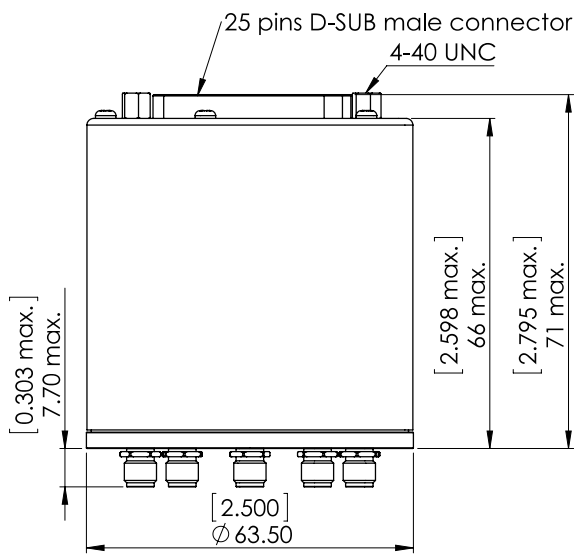

General tolerances :  $\pm 0,5$  mm [0,02 in]

**LABEL**

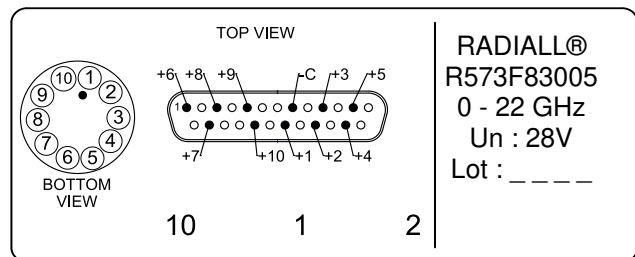

**SCHEMATIC DIAGRAM**

