

LOC	DIST	REVISIONS			
		REV	DATE	BY	CHKD
CM	00	T1	24JAN2013	KH	TM
		T2	08NOV2021	SS	VS

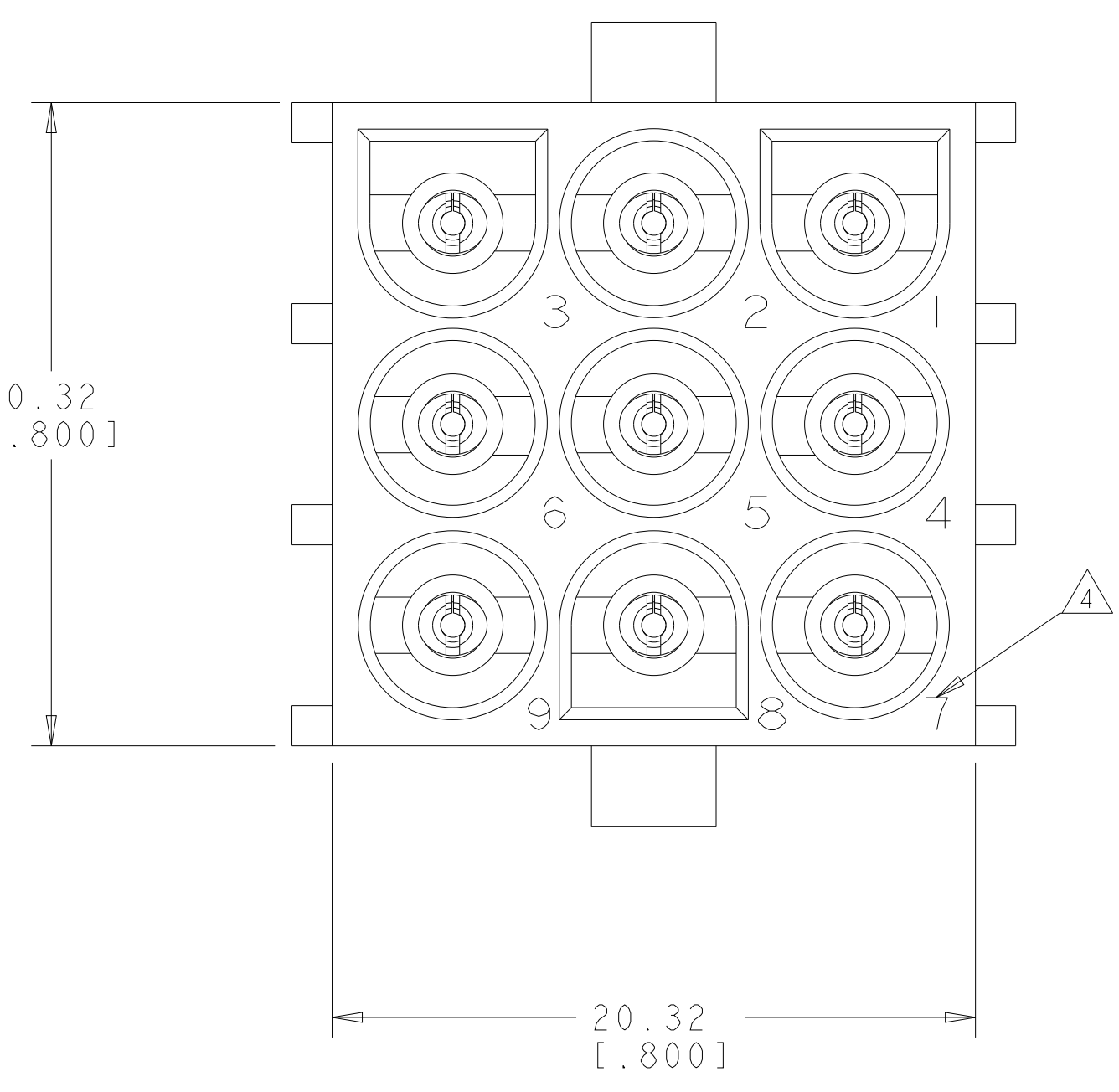

- PARTS COMPLY TO AMP SOLDERABILITY SPECIFICATION 109-11-3.
- CONTACT IS PLATED OVERALL WITH 0.00127 [.000050] NICKEL, THEN 0.00076 [.000030] GOLD OVER CONTACT LENGTH INDICATED AND TIN LEAD ON SOLDER TAIL END.
- MATES WITH HOUSING 480706.
- CIRCUIT IDENTIFICATION CHARACTERS ARE ADJACENT TO THE INDICATED CAVITIES, BUT LOCATION AND ORIENTATION MAY DIFFER FROM PRINT.
- CONTACT IS PLATED OVERALL WITH 0.00127 [.000050] NICKEL, THEN 0.00076 [.000030] GOLD OVER CONTACT LENGTH INDICATED AND MATTE TIN ON SOLDER TAIL END.
- DIMENSIONS IN BRACKETS ARE IN INCHES.
- SUPERSEDED BY 350586-4
- DIMENSIONS SHOWN REPRESENT PRODUCT IN DRY CONDITION. ADDITIONAL 2% GROWTH DUE TO END USE LOCATION MOISTURE ABSORPTION MAY OCCUR AND SHOULD BE ACCOUNTED FOR.

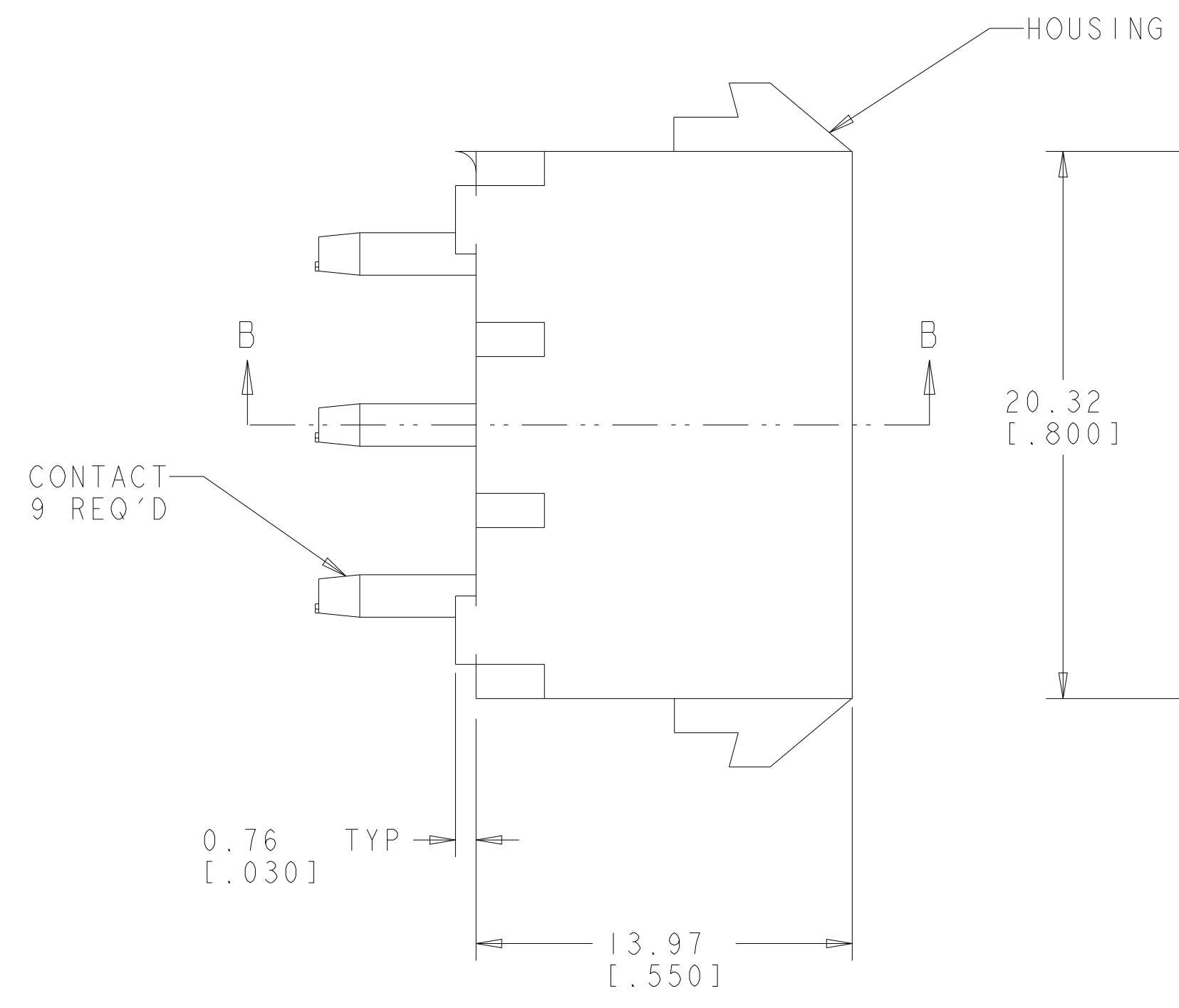
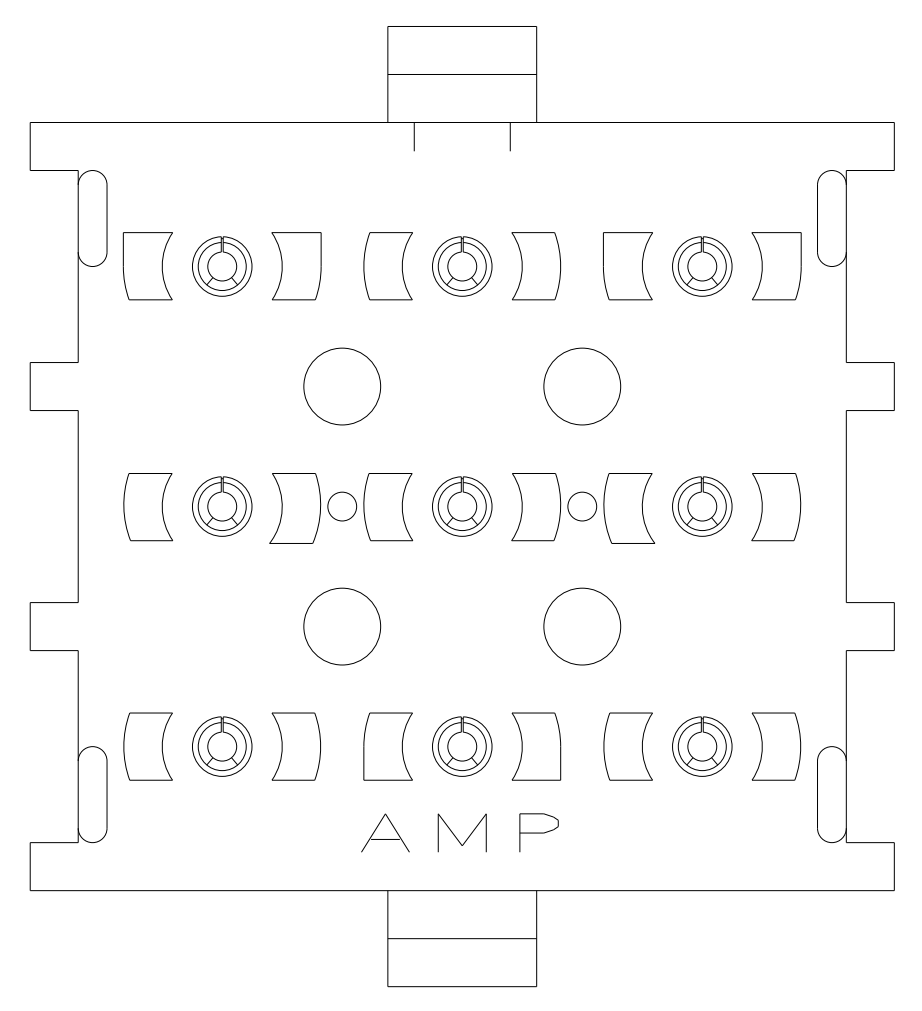
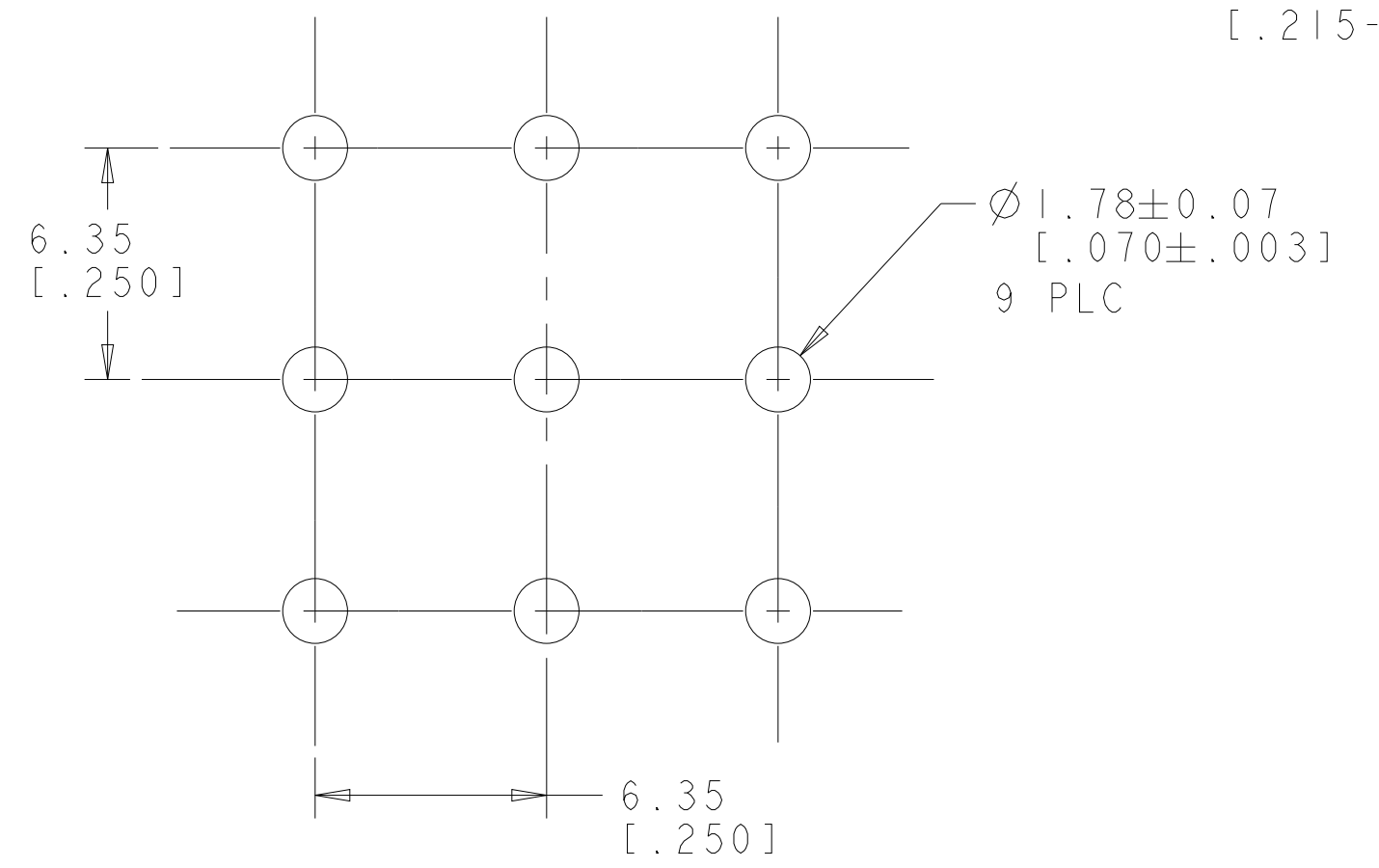
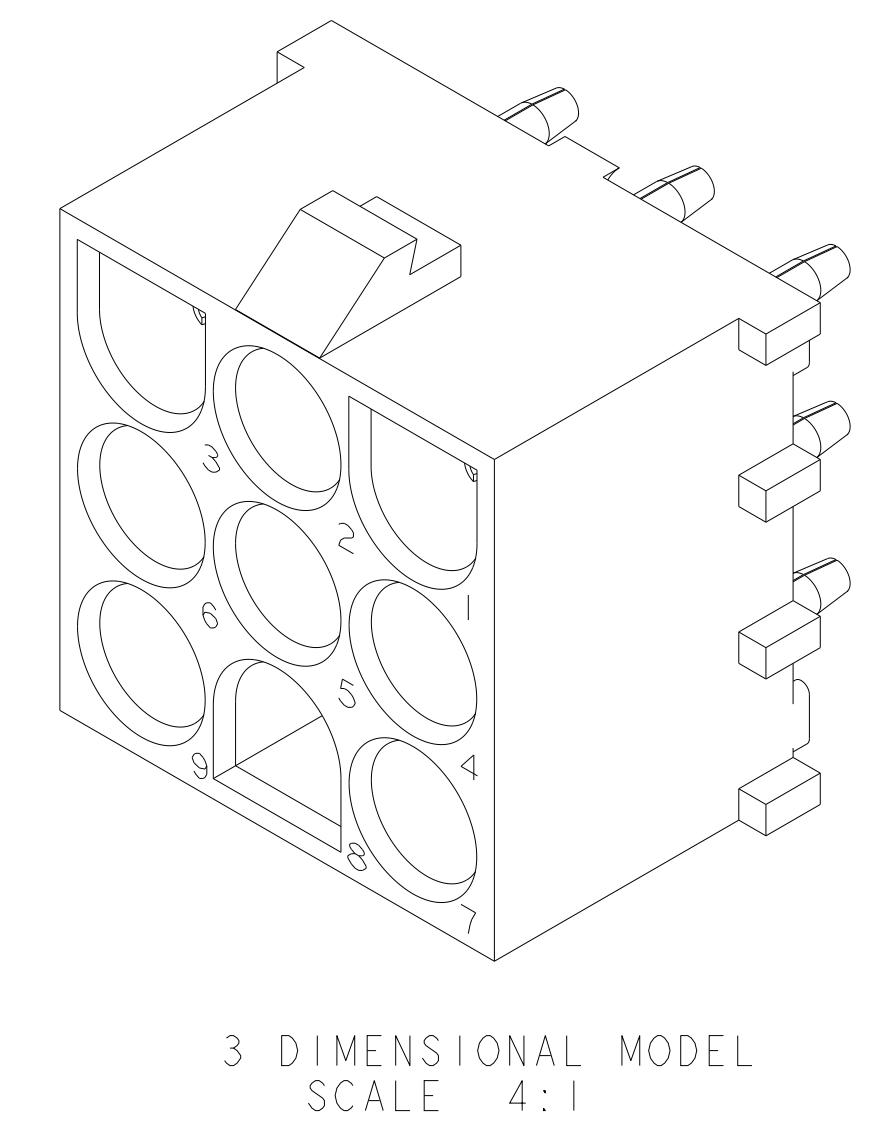
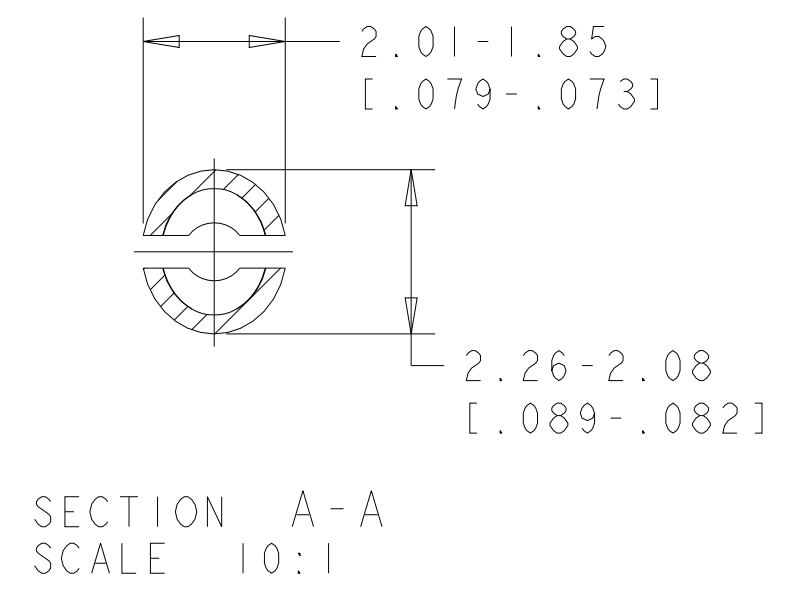
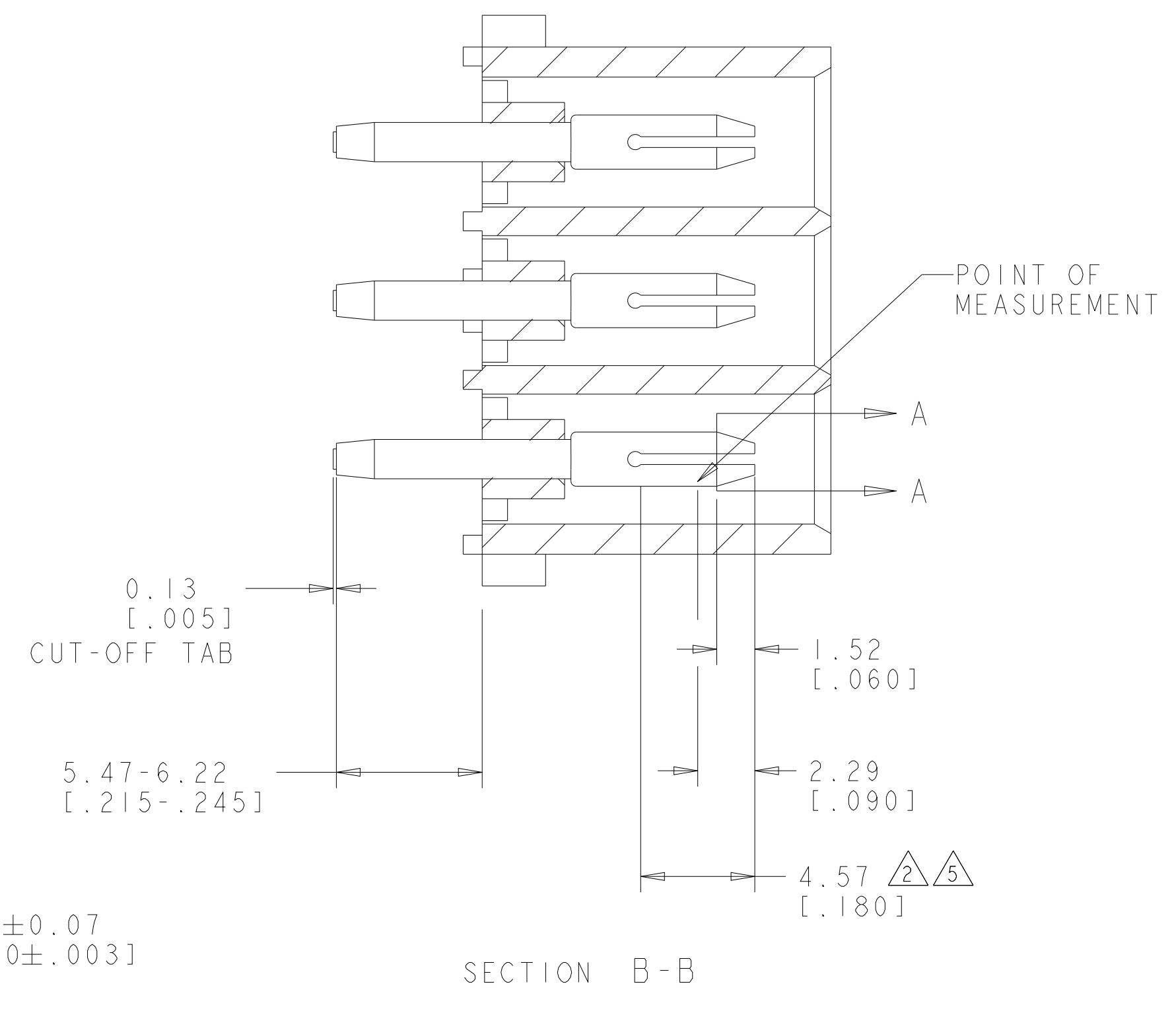

PHOSPOR BRONZE, GOLD	NYLON, UL94V-2, NATURAL	350586-4
PHOSPOR BRONZE, GOLD	NYLON, UL94V-2, NATURAL	350586-2
PHOSPOR BRONZE, PRE-TIN	NYLON, UL94V-2, NATURAL	350586-1
PIN CONTACT MATERIAL AND FINISH	HOUSING MATERIAL AND COLOR	PART NUMBER

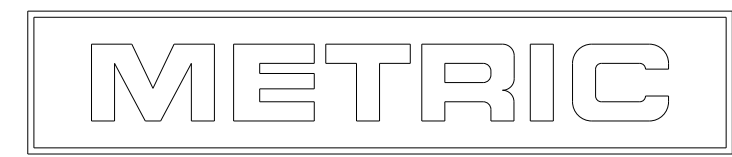

THIS DRAWING IS A CONTROLLED DOCUMENT.		OWN: K. WHITAKER 19JULY2005	TE Connectivity
DIMENSIONS: mm [INCHES]		CHK: S. RIDGILL 19JULY2005	
TOLERANCES UNLESS OTHERWISE SPECIFIED:		APVD: S. RIDGILL 19JULY2005	NAME: PIN HEADER ASSEMBLY, 9 CIRCUIT, UNIVERSAL MATE-N-LOK(TM)
0 PLC ±	1 PLC ±	PRODUCT SPEC	SIZE: A1
2 PLC ±0.13(.005)	3 PLC ±	APPLICATION SPEC	CAGE CODE: 350586
4 PLC ±	ANGLES ±40°30'	WEIGHT	RESTRICTED TO
MATERIAL: SEE TABLE	FINISH: SEE TABLE	CUSTOMER DRAWING	SCALE: 5:1 SHEET 1 OF 1 REV: T2