



IQS211AEV02 Quick start guide

Single Channel Capacitive Proximity/Touch Controller with movement detection

The IQS211A ProxSense® IC is a self-capacitance controller designed for applications where an awake/activate on proximity/touch function is required. The IQS211A offers ultra-low power options and uses movement detection for applications that require long term handling during proximity/touch. The device can be configured via OTP (One Time Programmable) bits.

1 Reference design and pin layout

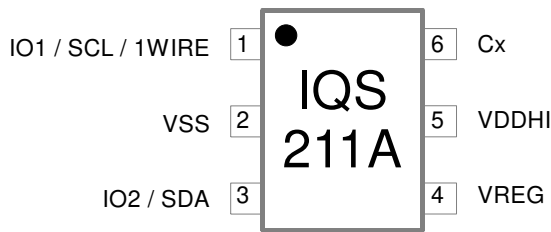

Figure 1.1 Pin Layout

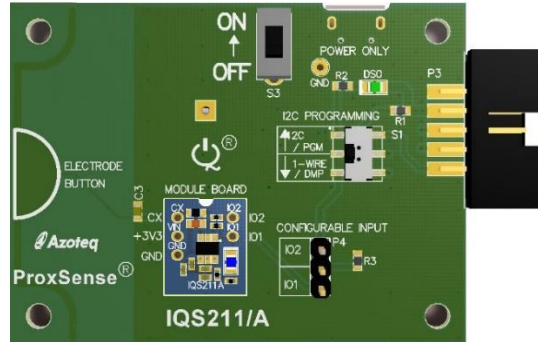

Figure 1.2 IQS211AEV02

Table 1.1 Pin-out description

IQS211A in TSOT23-6			
Pin	Name	Type	Function
1	IO1 / SCL / 1WIRE	Digital Input / Output	Multifunction IO1 / SCL / 1WIRE (I ² C Debug Clock signal / 1WIRE communication line)
2	VSS	Signal GND	
3	IO2 / SDA	Digital Input / Output	Multifunction IO2 / SDA (I ² C Debug Data output)
4	VREG	Regulator output	Requires external capacitor
5	VDDHI	Supply Input	Supply:1.8V – 3.3V
6	Cx	Sense electrode	Connect to conductive area intended for sensor

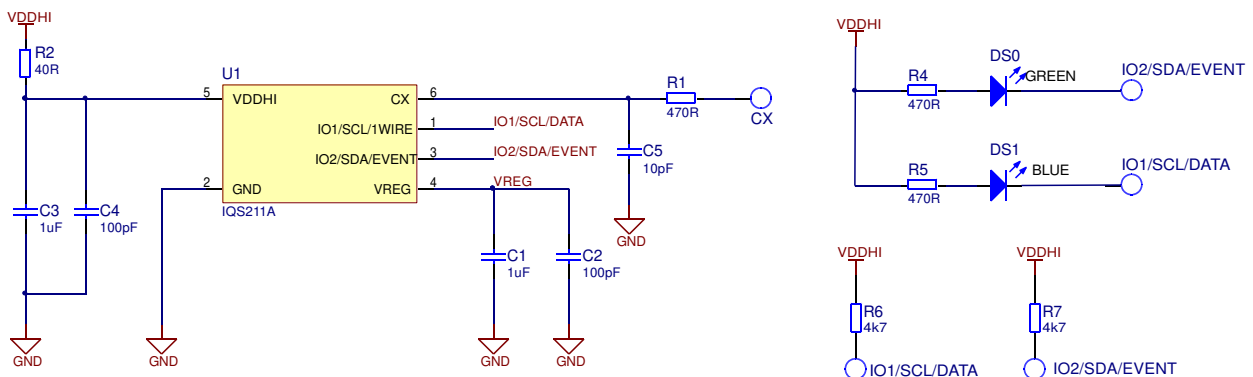

Figure 1.3 IQS211A Reference design

2 Ultra-low power configuration

For IQS211A 08000000 TSR devices (OTP Bank4: bit3 = 1 for VREG damping) the IQS211AEV02 main board can be configured to connect IO2 to R3 = 680Ω grounding resistor. This resistance is mandatory for the ultra-low power operational mode.

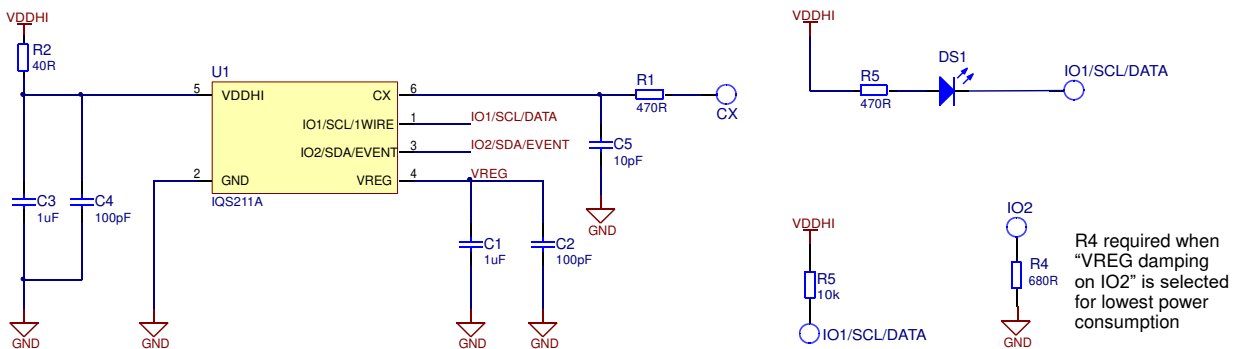
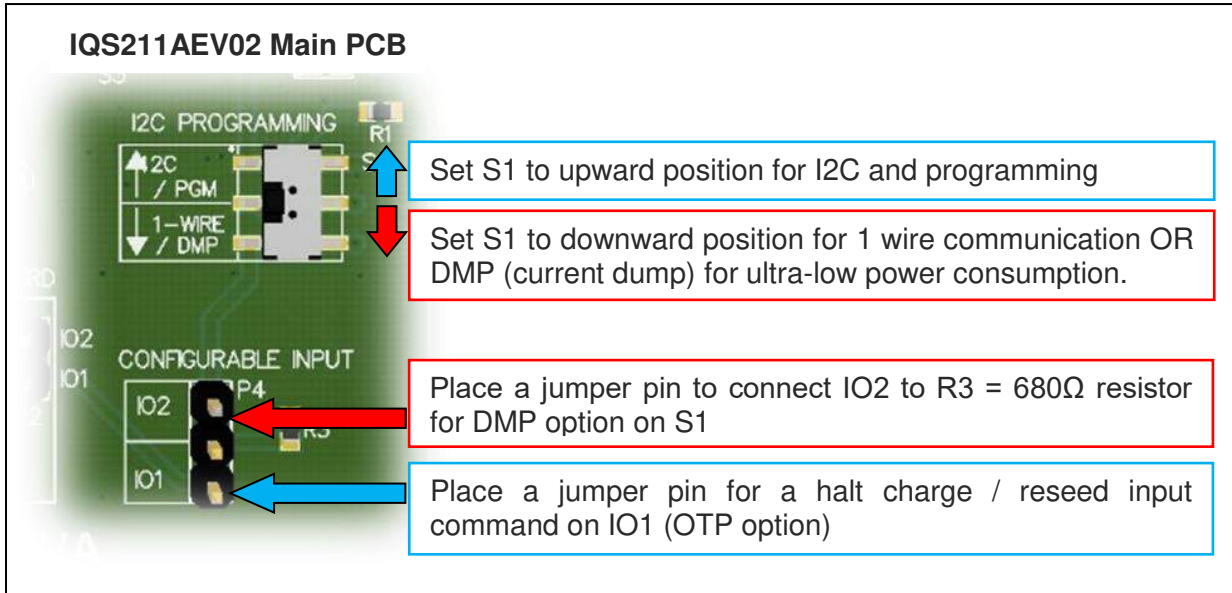

Figure 2.1 IQS211A reference design (Ultra-low power)

3 Default UI

Different UI's can be selected in the IQS211A GUI and can then be selected to run in standalone mode.

The GUI is available for download from the Software & Tools section of azoteq.com and the [CT210](#) (sold separately) is used in conjunction with the GUI to select the different UI's and settings.

Using [USBProg](#) the IQS211A can be configured in different variations. Please note when settings are programmed it is permanent.