

ENCLOSURE ASSEMBLY TOP VIEW

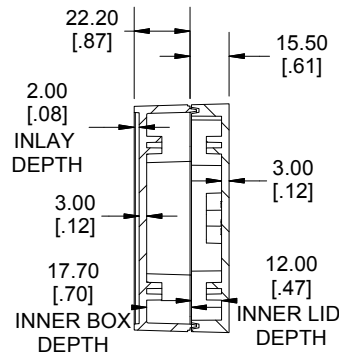

**SECTION A-A
END VIEW**

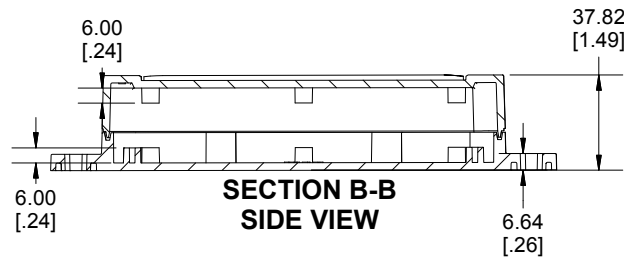
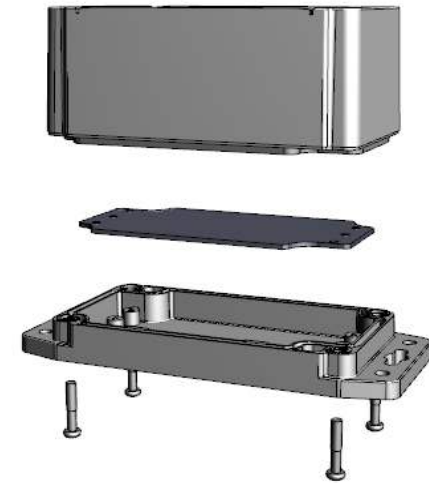

**SECTION B-B
SIDE VIEW**

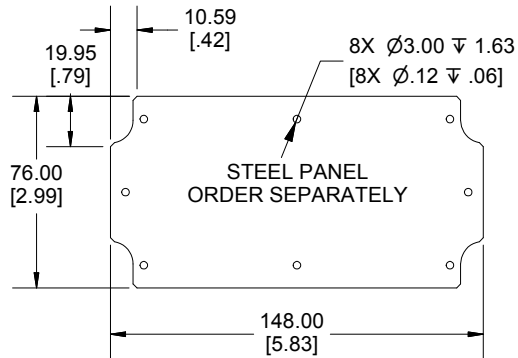

**STEEL PANEL
ORDER SEPARATELY**



Enclosures can be Factory Modified (Milling, Drilling, Printing etc.)
 Contact Factory njm@hammondmfg.com for quotes
 Solid models of this enclosure available in STEP or IGES.
 (Part number and text placement/orientation on our products are subject to change,
 we do not recommend using them as a locating reference for modification purposes)

NOTE

Purchased assembly includes styled box, flanged lid, 4 cover screws, and preformed silicone gasket.
 General Purpose ABS version is not UL approved. (Matl UL94 - HB)
 Polycarbonate version is UL 508 approved. (Matl UL94 - 5VA @ 3mm)

Recommended Cover screw torque -- 2.5 lbf-in (30 cN-m)

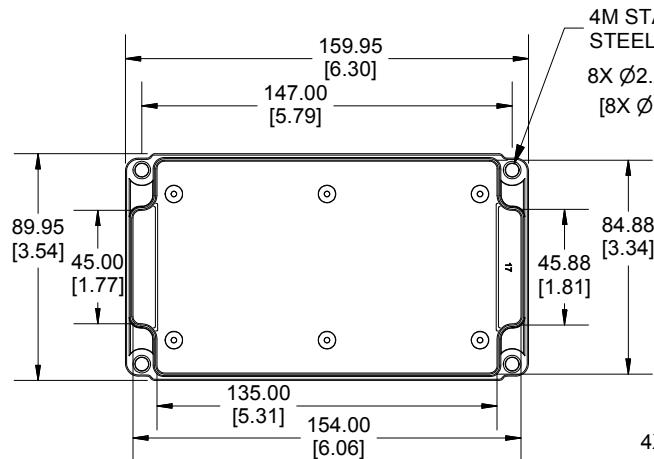

INSIDE BOX VIEW

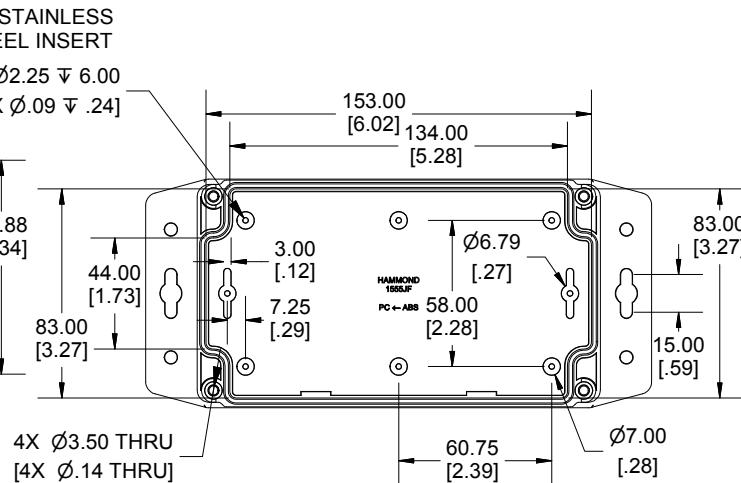

INSIDE LID VIEW

Dimensions:
 mm
 [inches]

1555JF	
1555JF Regular Enclosure	
General Purpose ABS RAL-7035	1555JF17GY
Polycarbonate RAL-7035	1555J2F17GY
ACCESSORIES	
Steel Inner Panels	1555JFPL
Steel Panel / P.C. Board Self Tapping Screw [#4 X 1/4" (6.4mm) Plated]	1555TS100
Cover Screws (Pkg 4) [M4 X 20mm Stainless Steel]	SC1554

**HAMMOND
MANUFACTURING®**

1555JF17

www.hammondmfg.com