

WSMP

Adaptor (Bullet)
Female to Female

W1K10C-K00D3

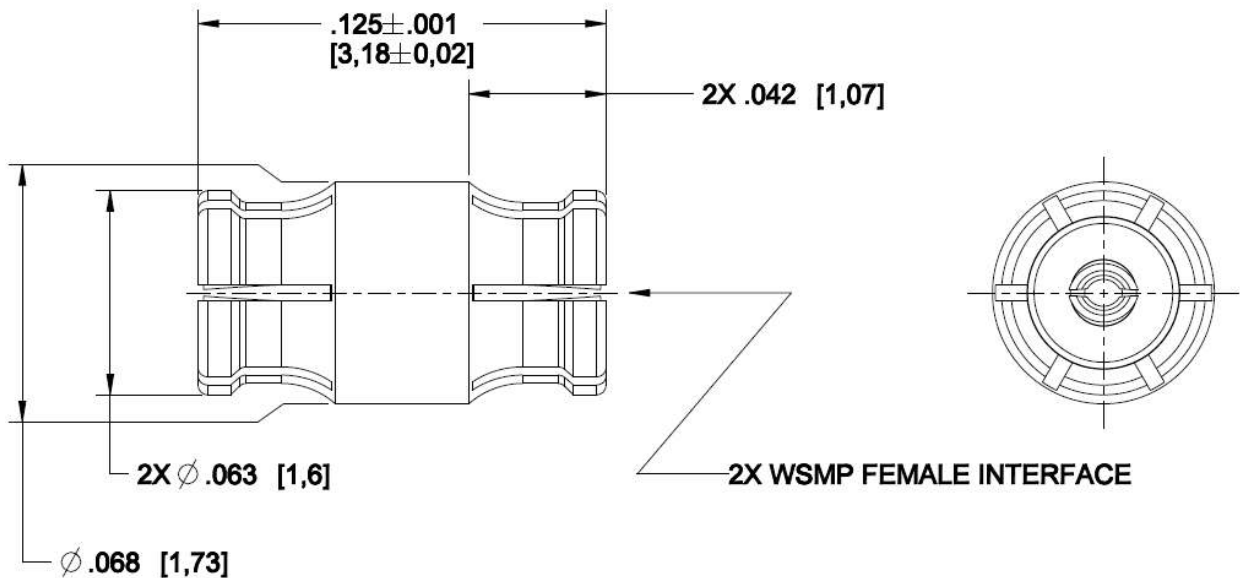
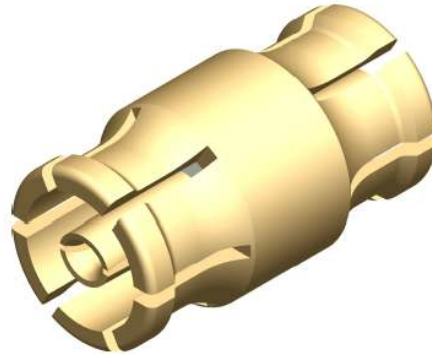

All dimensions are in inches [mm]
Unless otherwise specified, tolerances are as follows: .XXX ± .002 [0,05]

Interface

According to Rosenberger WSMP™ Interface standards

Material and plating

Connector parts

Body and contact

Material

CuBe per ASTM B196

Plating

Hard gold, 50µIN [1,27µm] min, over nickel, 50µIN [1,27µm] min

Dielectric

PTFE per ASTM D1710

Dieses Dokument ist urheberrechtlich geschützt • This document is protected by copyright • Rosenberger Hochfrequenztechnik GmbH & Co. KG

Technical Data Sheet**Rosenberger****WSMP**Adaptor (Bullet)
Female to Female**W1K10C-K00D3****Electrical data**

Impedance	50 Ω
Frequency	DC to 100 GHz
Return loss (typical)	≥ 26 dB, DC to 26.5 GHz ≥ 19 dB, 26.5 to 65 GHz
Insertion loss	≤ 0.12 x $\sqrt{f(\text{GHz})}$ dB
Insulation resistance	≥ 3.5 x 10 ³ MΩ
Center contact resistance	≤ 6.0 mΩ
Outer contact resistance	≤ 2.0 mΩ
Test voltage (at sea level)	250 V rms
RF High Potential (at sea level)	150 V rms @ 5 MHz
RF-leakage	≥ -80 dB (typical mated pair)

Mechanical data

Mating cycles	
- Full Detent	≥ 100
- Smooth Bore	≥ 500
Engagement force (typical)	
- Full Detent	2.5 lb _f [11 N]
- Smooth Bore	1.2 lb _f [5.3 N]
Disengagement force (typical)	
- Full Detent	4.5 lb _f [20 N]
- Smooth Bore	1.0 lb _f [4.5 N]

Environmental data

Temperature range	-55°C to +165°C
Thermal shock	MIL-STD-202-107, Condition B
Corrosion	MIL-STD-202-101
Vibration	MIL-STD-202-204, Condition D
Shock	MIL-STD-202-213, Condition I
Moisture resistance	MIL-STD-202-106, except Step 7B
2002/95/EC (RoHS)	compliant

Tooling

Installation/Extraction tool	W1W002-000
------------------------------	------------

Packing

Standard

Dieses Dokument ist urheberrechtlich geschützt • This document is protected by copyright • Rosenberger Hochfrequenztechnik GmbH & Co. KG

RF_35/05.10/6.0

Draft	Date	Approved	Date	Rev.	Engineering change number	Name	Date
R. Hosler	7/22/2013	J. Mohammed	7/22/2013	a01	Revised per ECN 19-0674	M. Peeran	5/16/2019
Rosenberger of North America, LLC P.O. Box 309 Akron, PA USA 17501 www.rosenbergerna.com					Tel. : +1.717.859.8900 Fax : +1.717.859.7044 Email : info@rosenbergerna.com		Page 2 / 2