

# DELPHI SERIES



## FEATURES

- ◆ ROHS Compliant
- ◆ Small size: 50.8 mm x 27.9 mm x 11.7mm (2.0" x 1.1" x 0.46")
- ◆ Industry standard footprint and pin-out
- ◆ Optimized for use with high frequency board mounted DC/DC converters
- ◆ ISO 9001, TL 9000, ISO 14001, QS9000, OHSAS18001 certified manufacturing facility
- ◆ Printed-circuit board mountable

## Delphi Series Filter Module - FL75L10A 75Vdc max input, 10A max output current

The Delphi series FL75L10A filter module is the latest offering from a world leader in power systems technology and manufacturing -- Delta Electronics, Inc. This filter module is designed to reduce the conducted common-mode and differential-mode noise on input or output lines of high-frequency switching power supplies and has a maximum current rating of 10A. It has the industry standard footprint and pin-out. With creative design technology and optimization of component placement, Delphi FL75L10A filter module possesses outstanding electrical and thermal performance, as well as extremely high reliability under highly stressful operating conditions.

## APPLICATIONS

- ◆ Common-mode and differential-mode filtering of power supply dc input and output line
- ◆ Computer application
- ◆ Communications equipment

# SPECIFICATIONS

GENERAL SPECIFICATIONS			OUTPUT SPECIFICATIONS		
Input voltage, continuous	Typical	0~75V	Output current	Ta=70°C, no airflow	10A
Input voltage, transient	Typical	100V	Output current	Ta=85°C, no airflow	8A
Operation case temperature	Typical	-40°C ~ 110°C	Common-mode Insertion Loss	50Ω circuit, 500 kHz (Typ)	30dB
Storage temperature	Typical	-55°C ~ 125°C	Differential-mode Insertion Loss	50Ω circuit, 500 kHz (Typ)	25dB
Size	(2.0"x1.1"x0.46")	50.8 mm x27.9 mm x11.7 mm			

# ELECTRICAL CHARACTERISTICS CURVES

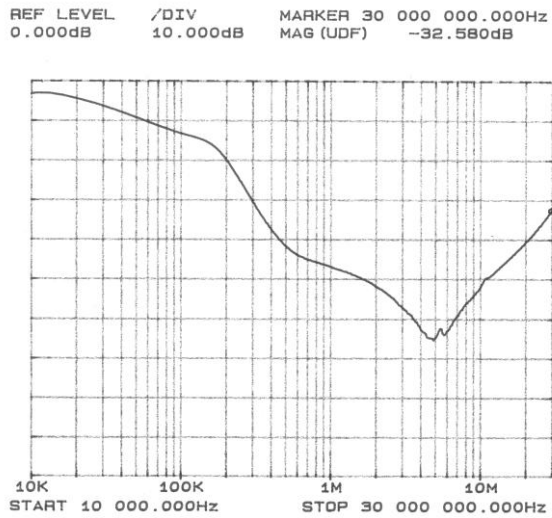

Figure 1: Typical common-mode insertion loss in a 50Ω circuit

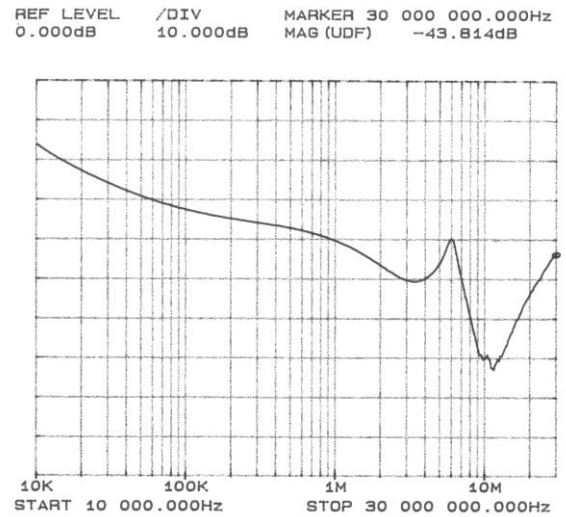

Figure 2: Typical differential-mode insertion loss in a 50Ω circuit

# Internal Schematics

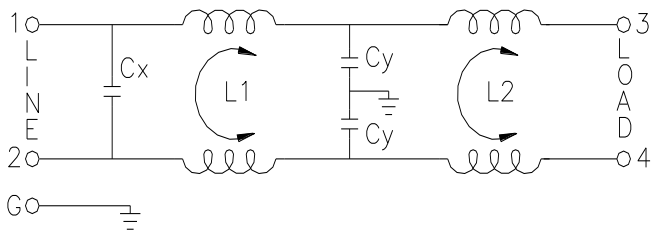

Figure 3: Internal schematics

## THERMAL CONSIDERATIONS

Thermal management is an important part of the system design. To ensure proper, reliable operation, sufficient cooling of the power module is needed over the entire temperature range of the module. Convection cooling is usually the dominant mode of heat transfer.

Hence, the choice of equipment to characterize the thermal performance of the power module is a wind tunnel.

### Thermal Testing Setup

Delta's filter modules are characterized in heated vertical wind tunnels that simulate the thermal environments encountered in most electronics equipment. This type of equipment commonly uses vertically mounted circuit cards in cabinet racks in which the power modules are mounted.

The following figure shows the wind tunnel characterization setup. The filter module is mounted on a test PWB and is vertically positioned within the wind tunnel. The space between the neighboring PWB and the top of the power module is 6.35mm (0.25").

### Thermal Derating

Heat can be removed by increasing airflow over the module. Figure 4 shows maximum output is a function of ambient temperature and airflow rate. To enhance system reliability, the power module should always be operated below the maximum operating temperature. If the temperature exceeds the maximum module temperature, reliability of the unit may be affected.

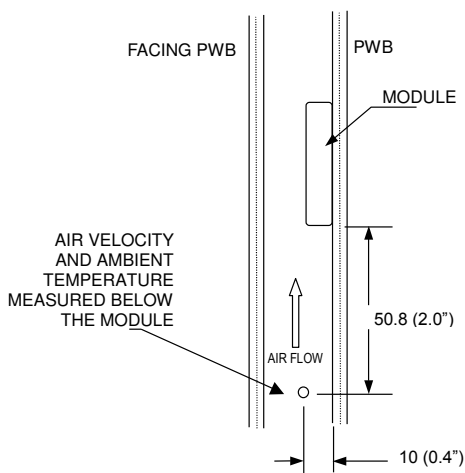

Note: Wind Tunnel Test Setup Figure Dimensions are in millimeters and (Inches)

Figure 4: Wind tunnel test setup figure dimensions are in millimeters and (inches).

## THERMAL CURVES

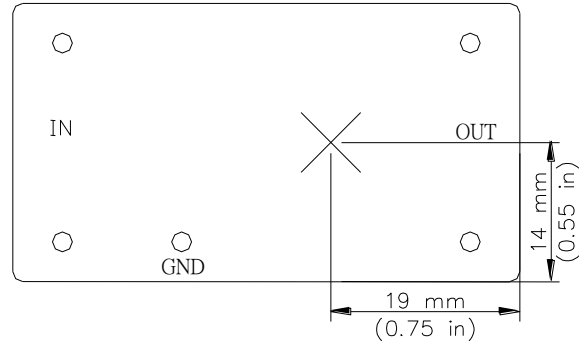

Figure 5: Temperature measurement location  
The allowed maximum hot spot temperature is defined at 110°C

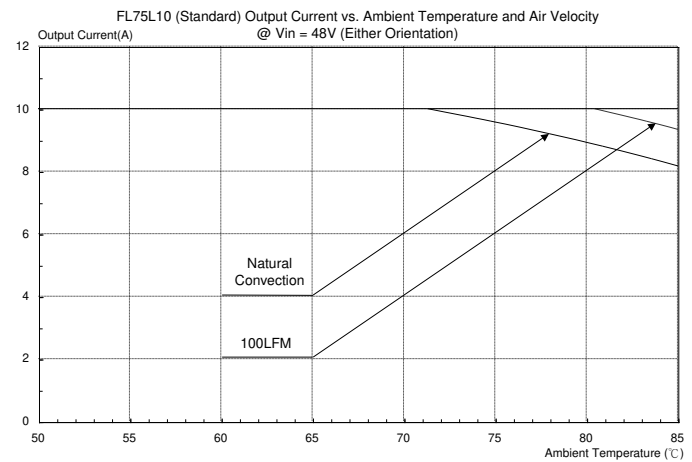
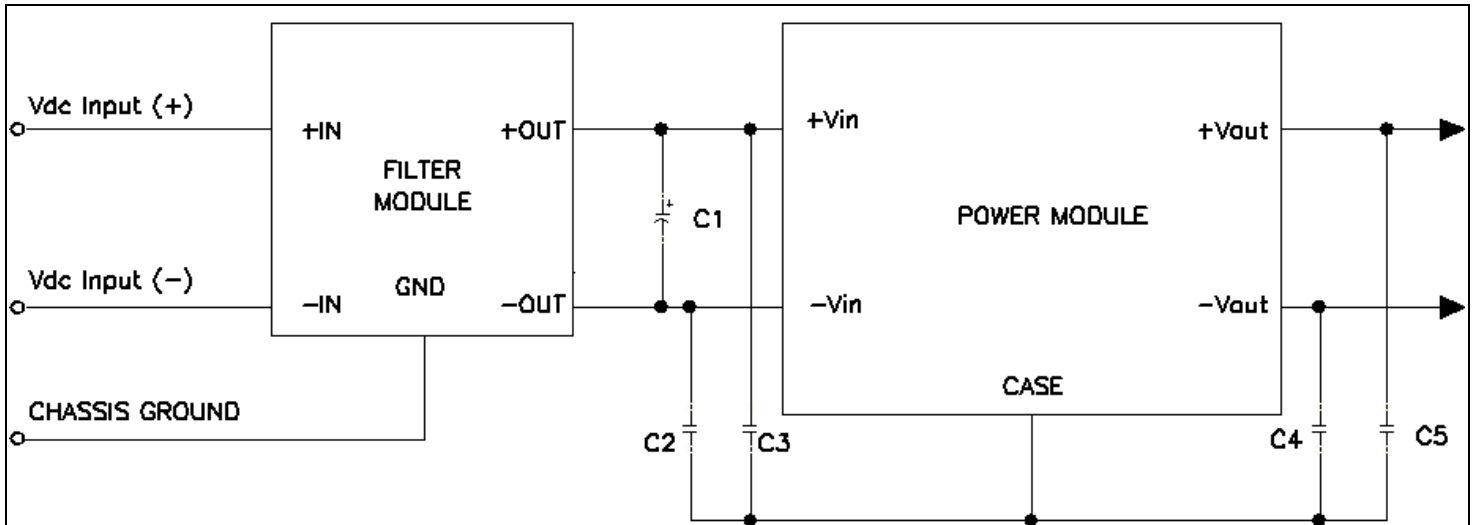

Figure 6: Output Current vs. Ambient Temperature and Air Velocity @ Vin = 48V (Either Orientation)

## APPLICATION



Note: C2 through C5 can be  $0.01\mu\text{F}$  to  $0.1\mu\text{F}$ . Select the voltage rating to meet input-to-output isolation requirements. C1 should be the recommended value indicated in the power module data sheet.

**Figure 7:** Recommended schematic when used as the input filter to a high-frequency dc-to-dc converter

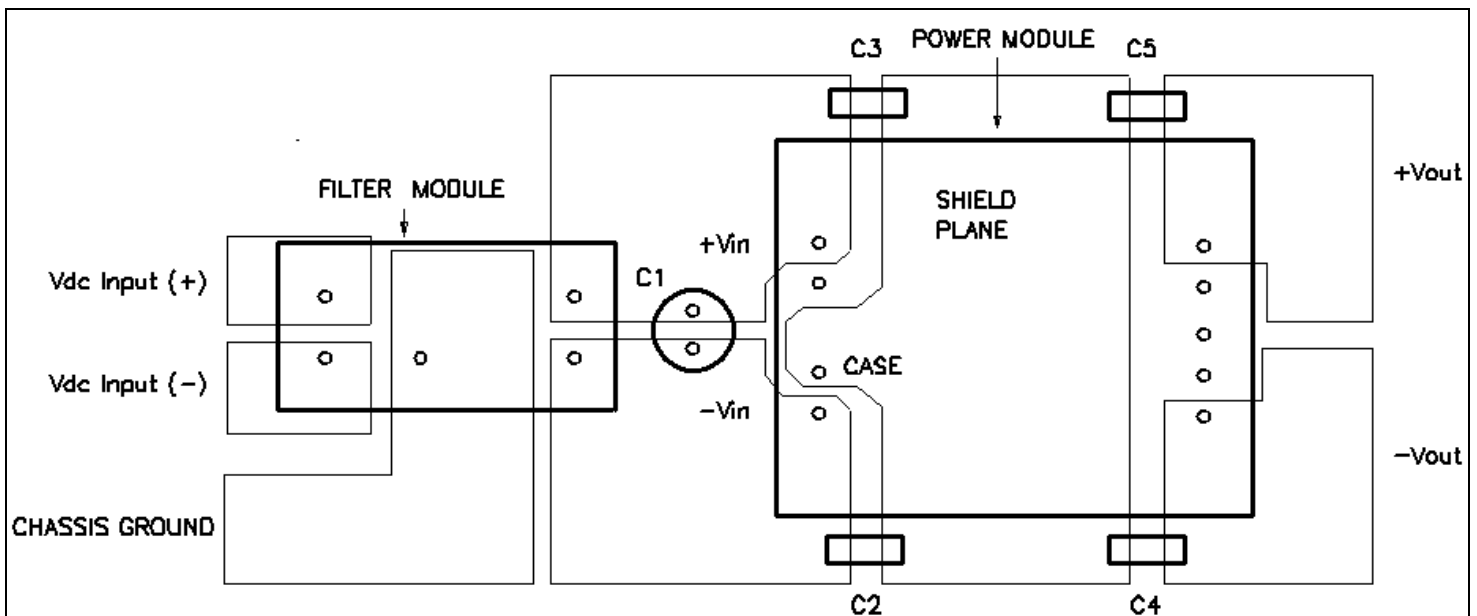

Note: Vdc input(+) and Vdc input(-) planes should overlay each other, as should the Vi(+) and Vi(-) planes, as should the Vout(+) and Vout(-) planes. Avoid routing signals or planes under the power module or the filter module. Ensure all connections are low impedance.

**Figure 8:** Recommended layout when used as the input filter to a high-frequency dc-to-dc converter



Figure 10 shows the experimental result obtained by using this filter module, together with the recommended external components shown in Figures 7 and 8. The Q48SR3R335NR module is one of the Delphi series quarter brick 3.3V, 35A DCDC converters. Measured noise is greatly dependent on layout, grounding, cable orientation, and load characteristics and the variation is possible from various application conditions.

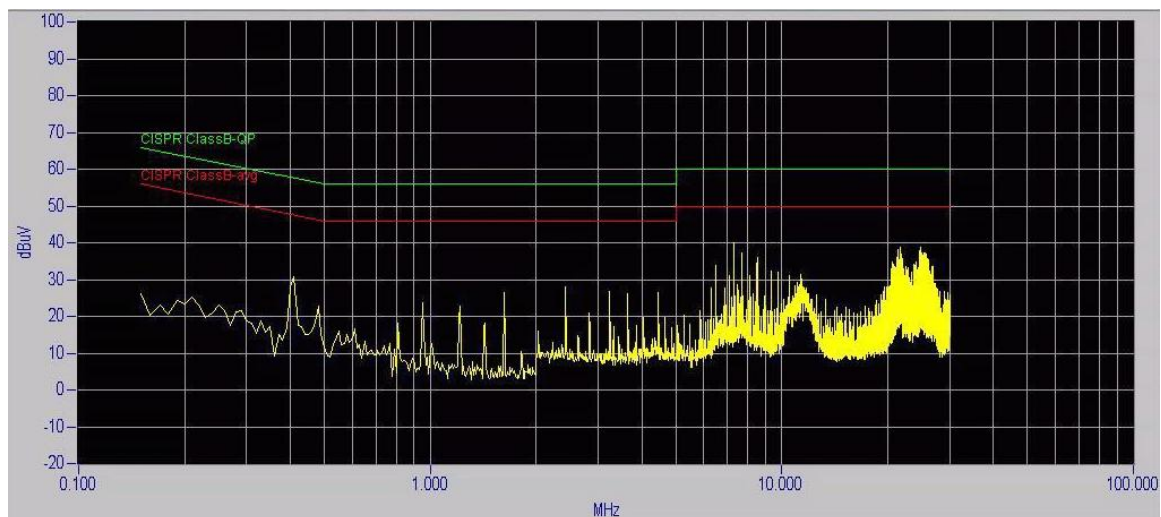
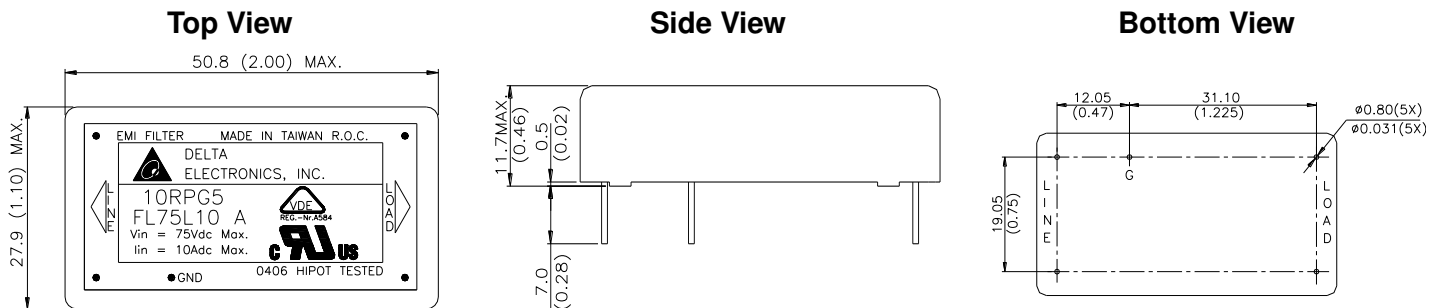

Figure 10: Q48SR3R335NR A conducted noise with FL75L10 input filter

## MECHANICAL DRAWING



Dimensions are in millimeter and (inches).

Tolerances : x.xx ± 0.5 mm (0.02 in), x.xxx ± 0.25 mm (0.010 in)

## RECOMMENDED HOLE PATTERN

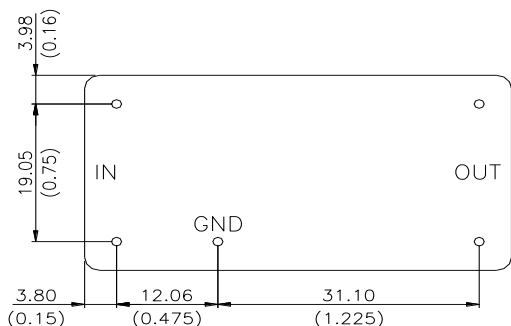

Dimensions are in millimeter and (inches).

Tolerances : x.xx ± 0.5 mm (0.02 in), x.xxx ± 0.25 mm (0.010 in)

## PART NUMBERING SYSTEM

FL	75	L	10		A
Product Family	Input Voltage	Product Series	Output Current	Space	Option Code
FL- Input EMI Filter	75- 0 ~ 75V	L – Industry standard	10 - 10A		A - Standard Functions B - 0.18" pin option

## MODEL LIST

Module Name	Input Voltage (max.)	Current Rating (max.)
FL75L10 A	100V	10A
FL75L10 B	100V	10'A

### CONTACT: [www.deltaww.com/dcdc](http://www.deltaww.com/dcdc)

#### USA:

Telephone:  
East Coast: 978-656-3993  
West Coast: 510-668-5100  
Fax: (978) 656 3964  
Email: [DCDC@delta-corp.com](mailto:DCDC@delta-corp.com)

#### Europe:

Telephone: +31-20-655-0967  
Fax: +31-20-655-0999  
Email: [DCDC@delta-es.com](mailto:DCDC@delta-es.com)

#### Asia & the rest of world:

Telephone: +886 3 4526107 ext 6220-6224  
Fax: +886 3 4513485  
Email: [DCDC@delta.com.tw](mailto:DCDC@delta.com.tw)

## WARRANTY

Delta offers a two (2) year limited warranty. Complete warranty information is listed on our web site or is available upon request from Delta.

Information furnished by Delta is believed to be accurate and reliable. However, no responsibility is assumed by Delta for its use, nor for any infringements of patents or other rights of third parties, which may result from its use. No license is granted by implication or otherwise under any patent or patent rights of Delta. Delta reserves the right to revise these specifications at any time, without notice.