

THIS DRAWING IS UNPUBLISHED. RELEASED FOR PUBLICATION  
 © COPYRIGHT BY TYCO ELECTRONICS CORPORATION. ALL RIGHTS RESERVED.

LOC	DIST	REVISIONS					
AA	22	P	LTR	DESCRIPTION	DATE	DWN	APVD
		B1		REV PER ECR-09-004284	16APR2009	TY	SY

- 1 MATERIAL: HOUSING - NYLON, BLACK, IR REFLOW COMPATIBLE, UL 94V-0.  
 TERMINALS - 0.33[.013] THICK PHOS BRONZE PLATED WITH 1.27µm[.000050] MINIMUM THICK HARD GOLD IN LOCALIZED AREA AND 3.81µm [.000150] MINIMUM THICK MATTE TIN IN SOLDER AREA OVER 1.27µm[.000050] MINIMUM THICK NICKEL UNDERPLATE.  
 SHIELDS - 0.25[.010] THICK COPPER ALLOY PLATED WITH 1.27µm[.000050] MINIMUM NICKEL AND 2.03µm [.000080] MINIMUM HOT TIN DIP ON PCB GROUND TABS.
- △ JACK CAVITY CONFORMS TO FCC RULES AND REGULATIONS, PART 68 SUBPART F.
- △ USE #30 DRILL BIT OR 3.25mm DRILL BIT WHEN PRODUCING THESE PCB HOLES.

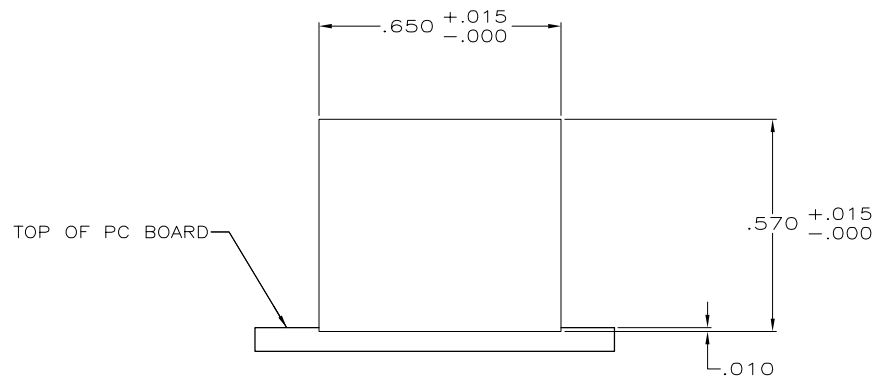
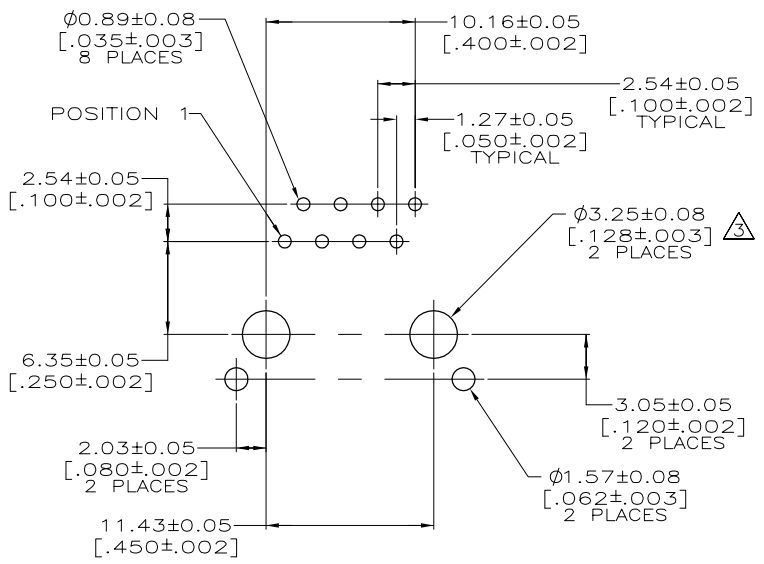
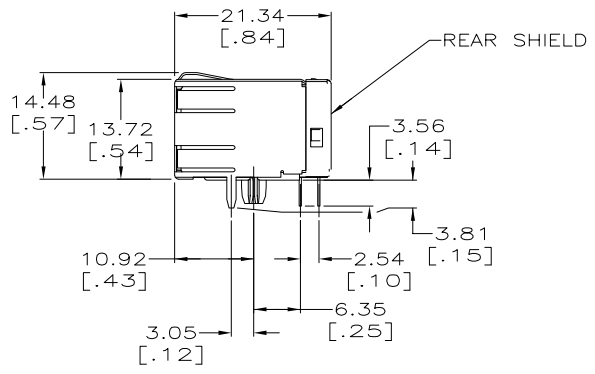
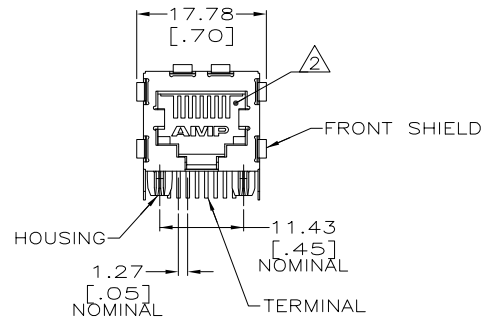

SUGGESTED PANEL CUTOUT  
 SCALE 4:1

SUGGESTED PC BOARD LAYOUT  
 COMPONENT SIDE (TOP)  
 SCALE 4:1

5406295-1  
 PART NUMBER

THIS DRAWING IS A CONTROLLED DOCUMENT.		DWN T. SPRINKLE / 01JUN2005	Tyco Electronics Corporation Harrisburg, Pa 17105-3608	
DIMENSIONS: mm		CHK J. WESTMAN / 01JUN2005	APVD S. FLECKINGER / 01JUN2005	
TOLERANCES UNLESS OTHERWISE SPECIFIED:		NAME		PRODUCT SPEC
0 PLC ± -	1 PLC ± -	108-1163		MODULAR JACK ASSEMBLY, SINGLE PORT, 8 POSITION, SHIELDED, REVERSE PANEL GROUND TABS, CATEGORY 4
2 PLC ± 0.25[.01]	3 PLC ± 0.13[.005]	APPLICATION SPEC		SIZE CAGE CODE DRAWING NO RESTRICTED TO
4 PLC ± -	ANGLES ± -	114-2048		A2 00779 C=5406295
MATERIAL FINISH		WEIGHT		CUSTOMER DRAWING
SEE NOTE 1		SEE NOTE 1		SCALE 2:1 SHEET 1 OF 1 REV B1