

5

4

2

1

©1962 BY AMP INCORPORATED. ALL RIGHTS RESERVED. AMP PRODUCTS COVERED BY PATENTS AND/OR PATENTS PENDING.

NUMBER 582355

REVISIONS				
ZONE	LTR	DESCRIPTION	DATE	APPROVED
	P	REV PER 0010-1582-95	1-30-97	P.O.
	R	REV PER EC. 0310-148-96	20 JUN 97	DG
	S	OBS-16 & -17 PER EC. 0652-67-98	11 SEP 98	CR

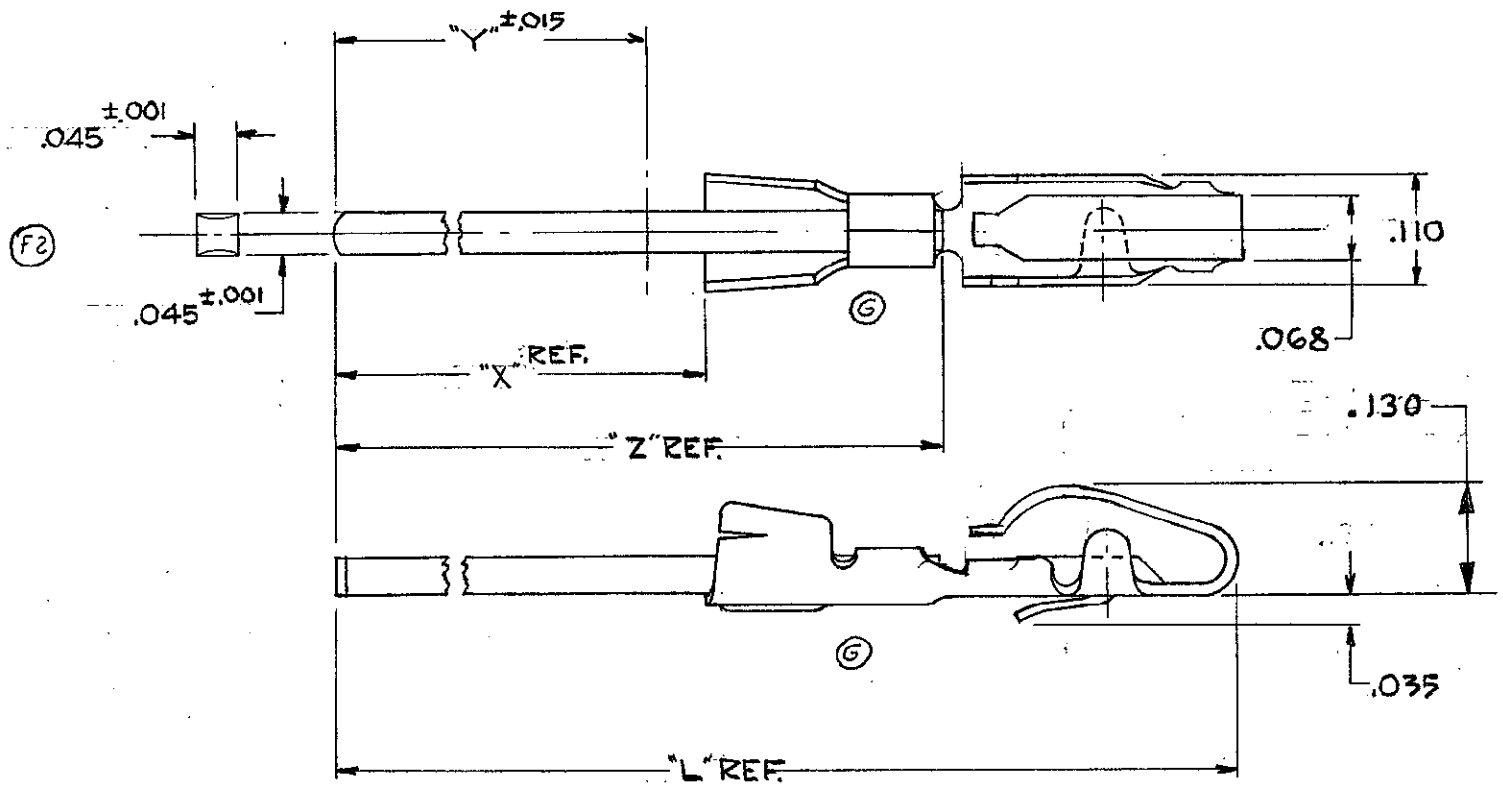

	PART No	"X"	"Y" WRAP LENGTH	"Z"	"L"
OBSOLETE	582355-1	1.062	1.000	1.332	1.662
OBSOLETE	582355-2	.862	.800	1.132	1.462
OBSOLETE	582355-3	.662	.600	.932	1.262
OBSOLETE	582355-4	.462	.400	.732	1.062

C

B

A

D

C

B

A

UNLESS OTHERWISE SPECIFIED DIM. ARE IN INCHES. TOLERANCES ON: DECIMALS $\pm .005$ ANGLES $\pm$	CONTRACT NO.	<b>AMP</b> AMP INCORPORATED HARRISBURG, PENNSYLVANIA	
	DR D. Baer 5-18-66	NAME AMP LEAF POST TYPE ASSEMBLY	
	CHK J.S. Heide 5/25/66	SIZE B	CODE IDENT NO. 00779
	APPD J. Kaufman 5/31/66	NUMBER 582355	SCALE 5:1
MATERIAL RECD: PHOS. BRONZE .00003 GOLD	DSGN APPD	WT CALC ACTUAL SHEET 1 OF 2	
WIRE: TIN.	OTHER APPD R. Halley 5/31/66	CUSTOMER DRAWING	
HEAT TREAT H	FINISH SEE "MATL."		

AMP INFO	LOC AD	PRINT 00
----------	--------	----------

©1962 BY AMP INCORPORATED. ALL RIGHTS RESERVED. AMP PRODUCTS COVERED BY PATENTS AND/OR PATENTS PENDING.

ZONE		LTR	DESCRIPTION	DATE	APPROVED
1.5			SEE SHEET 1		

NUMBER 582355

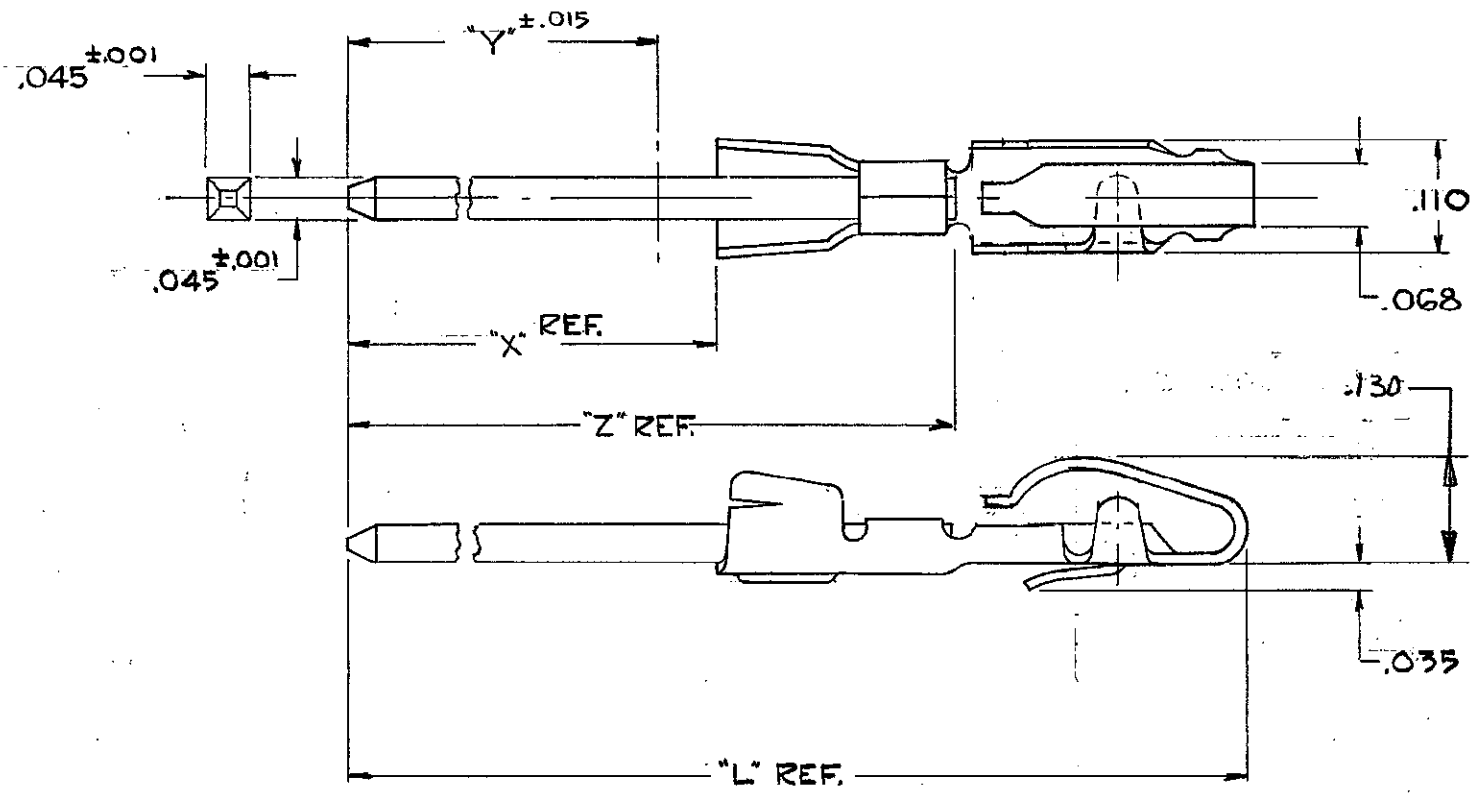

PART NO	"X"	"Y" WRAP LENGTH	"Z"	"L"	RECEPTACLE FINISH
582355-5	1.062	1.000	1.332	1.662	
582355-6	.862	.800	1.132	1.462	1
582355-7	.662	.600	.932	1.262	
582355-8	.462	.400	.732	1.062	
<del>582355-9</del>	<del>1.062</del>	<del>1.000</del>	<del>1.332</del>	<del>1.662</del>	
<del>1-582355-0</del>	<del>.862</del>	<del>.800</del>	<del>1.132</del>	<del>1.462</del>	2
<del>1-582355-1</del>	<del>.662</del>	<del>.600</del>	<del>.932</del>	<del>1.262</del>	
<del>1-582355-2</del>	<del>.462</del>	<del>.400</del>	<del>.732</del>	<del>1.062</del>	
<del>1-582355-3</del>	<del>1.062</del>	<del>1.000</del>	<del>1.332</del>	<del>1.662</del>	
<del>1-582355-4</del>	<del>.862</del>	<del>.800</del>	<del>1.132</del>	<del>1.462</del>	3
<del>1-582355-5</del>	<del>.662</del>	<del>.600</del>	<del>.932</del>	<del>1.262</del>	
<del>1-582355-6</del>	<del>.462</del>	<del>.400</del>	<del>.732</del>	<del>1.062</del>	
<del>1-582355-7</del>	<del>.862</del>	<del>.800</del>	<del>1.132</del>	<del>1.462</del>	4
<del>1-582355-8</del>	<del>.662</del>	<del>.600</del>	<del>.932</del>	<del>1.262</del>	
<del>1-582355-9</del>	<del>.862</del>	<del>.800</del>	<del>1.132</del>	<del>1.462</del>	PLAIN
2-582355-0	.275	.213	.545	.875	4

- 1 .000015 GOLD.
- 2 .000015 SELECTIVE GOLD PLATE CONTACT AREA OVER GOLDFLASH ENTIRE CONTACT.
- 3 .000015 SELECTIVE GOLD PLATE CONTACT AREA OVER NICKEL ENTIRE CONTACT.
- 4 .000030 SELECTIVE GOLD PLATE CONTACT AREA OVER GOLD FLASH ENTIRE CONTACT.

UNLESS OTHERWISE SPECIFIED DIM. ARE IN INCHES. TOLERANCES ON: DECIMALS ± .005 ANGLES ± #	CONTRACT NO.	AMP INCORPORATED HARRISBURG, PENNSYLVANIA	
	DR D. Bar 9-18-66	AMP LEAF POST TYPE ASSEMBLY	
MATERIAL RECP. PHOS. BRONZE FINISH AS ABOVE	CHK J.S. Heide 5/25/66	NAME	AMP LEAF POST TYPE ASSEMBLY
WIRE: PHOS. BRONZE TIN.	APPD J. Kaufman 5/2/66	SIZE B	CODE IDENT NO. 00779
AMP INFO	OTHER APPD H. Holliday 5/31/66	NUMBER	582355
LOC AD	PRINT DIST 100	SCALE	5:1
HEAT TREAT H	FINISH SEE "MATL."	WT CALC	ACTUAL
		SHEET	2 OF 2