

PRODUCT NUMBER
SEE TABLE, SHEET 5

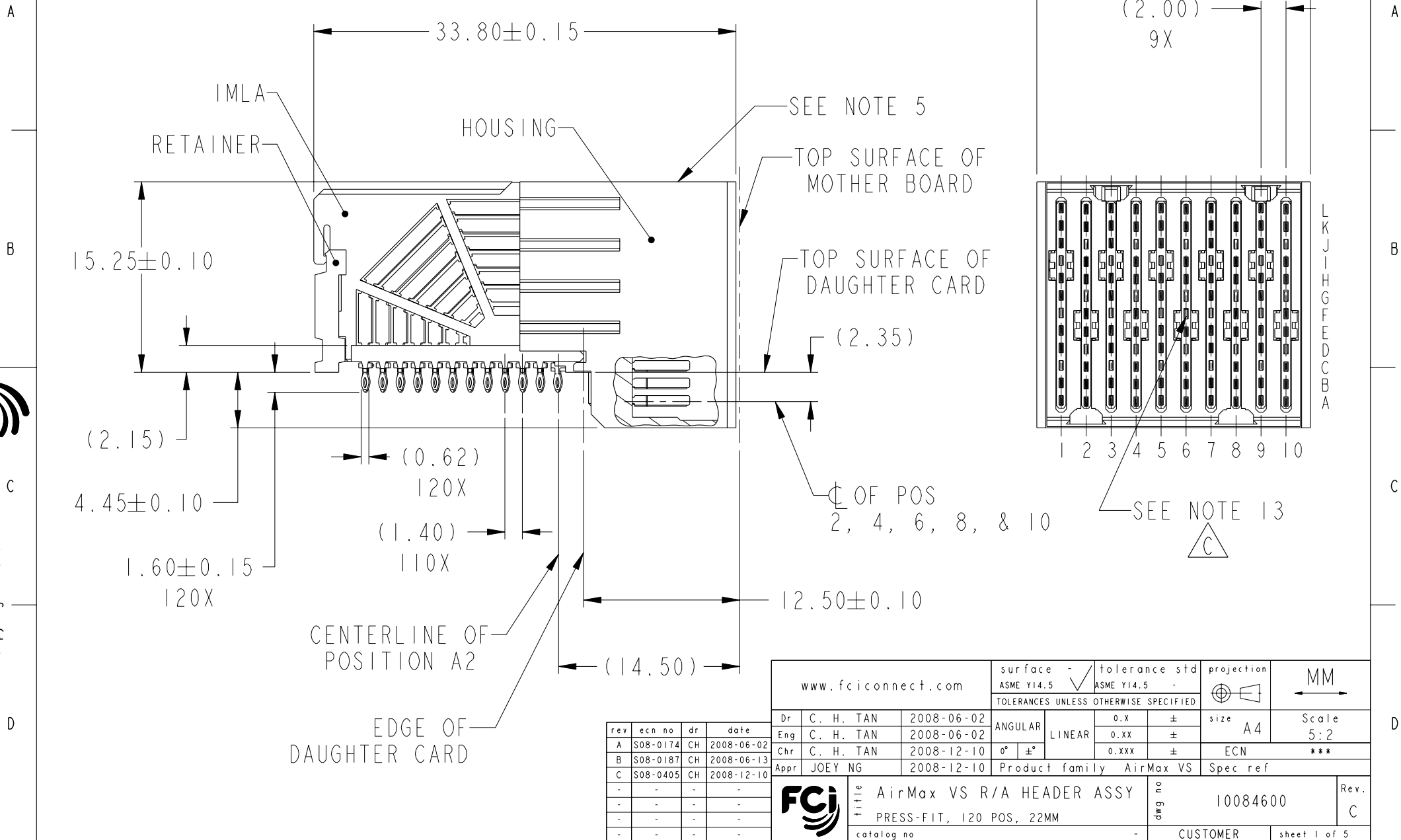

Copyright FCI.

rev	ecn no	dr	date
A	S08-0174	CH	2008-06-02
B	S08-0187	CH	2008-06-13
C	S08-0405	CH	2008-12-10
-	-	-	-
-	-	-	-
-	-	-	-
-	-	-	-

www.fciconnect.com		surface - ASME Y14.5	tolerance std - ASME Y14.5	projection	MM
		TOLERANCES UNLESS OTHERWISE SPECIFIED			Scale 5:2
Dr	C. H. TAN	2008-06-02	ANGULAR	size A4	ECN ***
Eng	C. H. TAN	2008-06-02	LINEAR		
Chr	C. H. TAN	2008-12-10	0° ±°		
Appr	JOEY NG	2008-12-10	Product family AirMax VS		Spec ref
		AirMax VS R/A HEADER ASSY		dwg no	10084600
		PRESS-FIT, 120 POS, 22MM			Rev. C
		catalog no	-	CUSTOMER	sheet 1 of 5

REV F - 2006-04-17



Copyright FCI.

DESCRIPTION	DIM A	DIM B	DIM C
2-22MM MODULES PLACED END-TO-END	4.00	21.90 2X	22.00
1-20MM MODULE & 1-22MM MODULE PLACED END-TO-END	3.00	19.90 1X & 21.90 1X	21.00

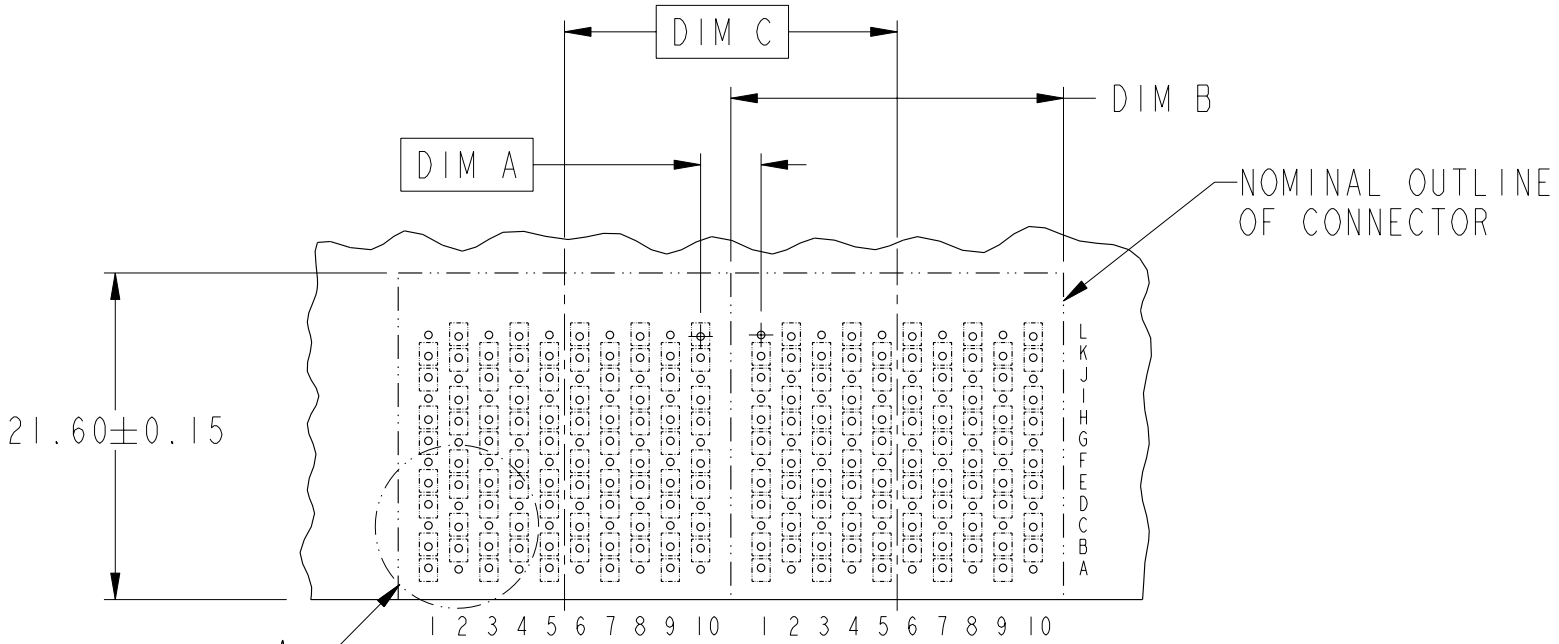

DETAIL A

RECOMMENDED PCB LAYOUT
FOR DIFFERENTIAL APPLICATIONS
COMPONENT SIDE
(TWO ADJACENT FOOTPRINTS SHOWN)
NOTES 6 & 7



TITLE	AirMax VS R/A HEADER ASSY		dwg no	10084600	Rev.	C
	PRESS-FIT, 120 POS, 22MM					
CATALOG NO	-	CUSTOMER	sheet 2 of 5			

DESCRIPTION	DIM D	DIM E	DIM F
2-22MM MODULES PLACED END-TO-END	4.00	21.90 2X	22.00
1-20MM MODULE & 1-22MM MODULE PLACED END-TO-END	3.00	19.90 1X & 21.90 1X	21.00

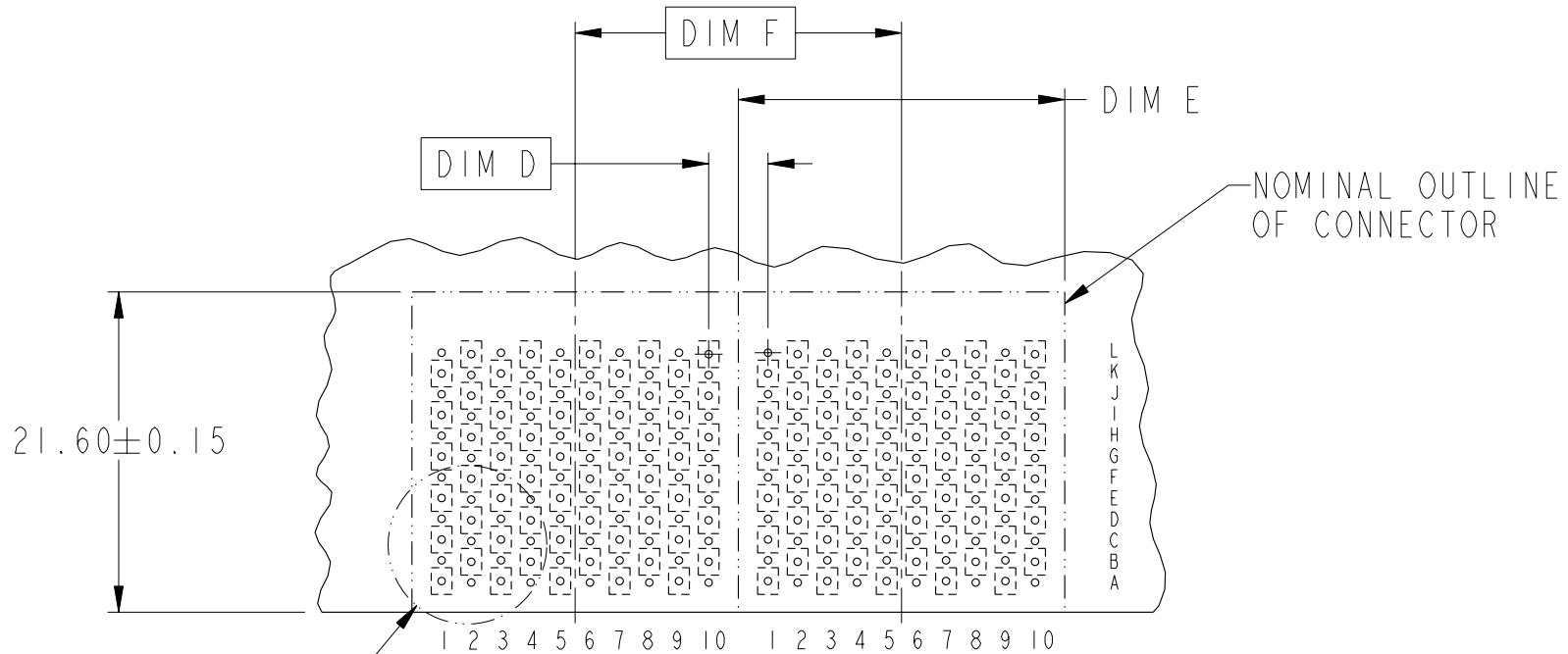

RECOMMENDED PCB LAYOUT
FOR SINGLE ENDED APPLICATIONS
COMPONENT SIDE
(TWO ADJACENT FOOTPRINTS SHOWN)
NOTES 6 & 7



title AirMax VS R/A HEADER ASSY
PRESS-FIT, 120 POS, 22MM
catalog no -

dwg no 10084600

Rev. C

CUSTOMER sheet 3 of 5



Copyright FCI.

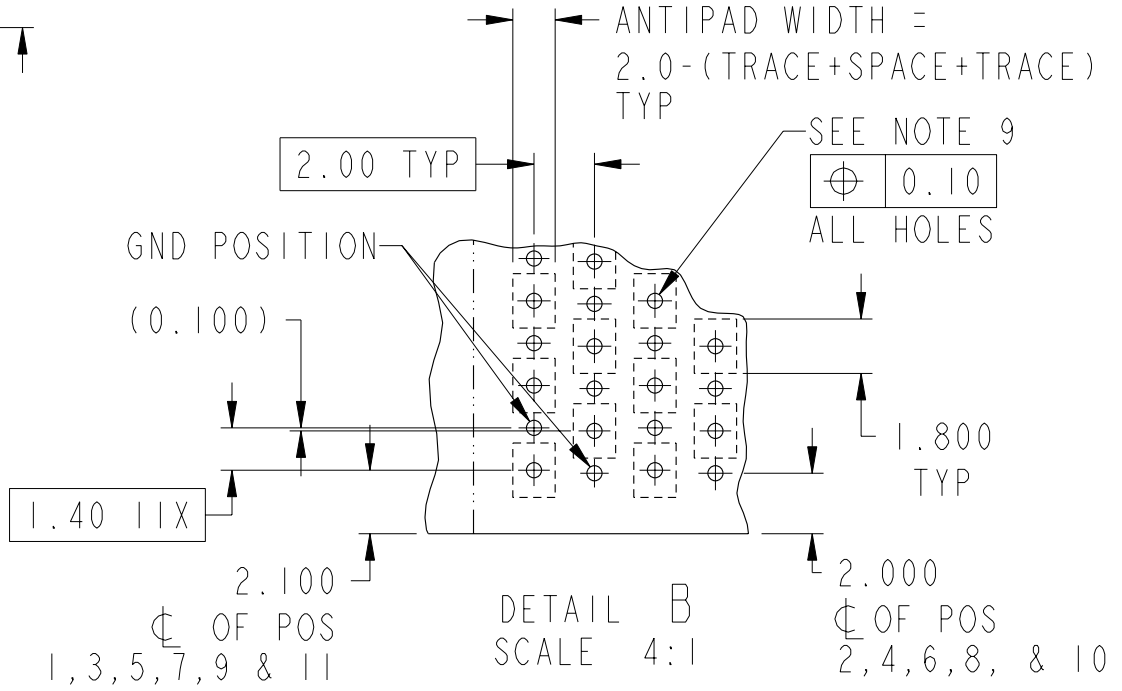
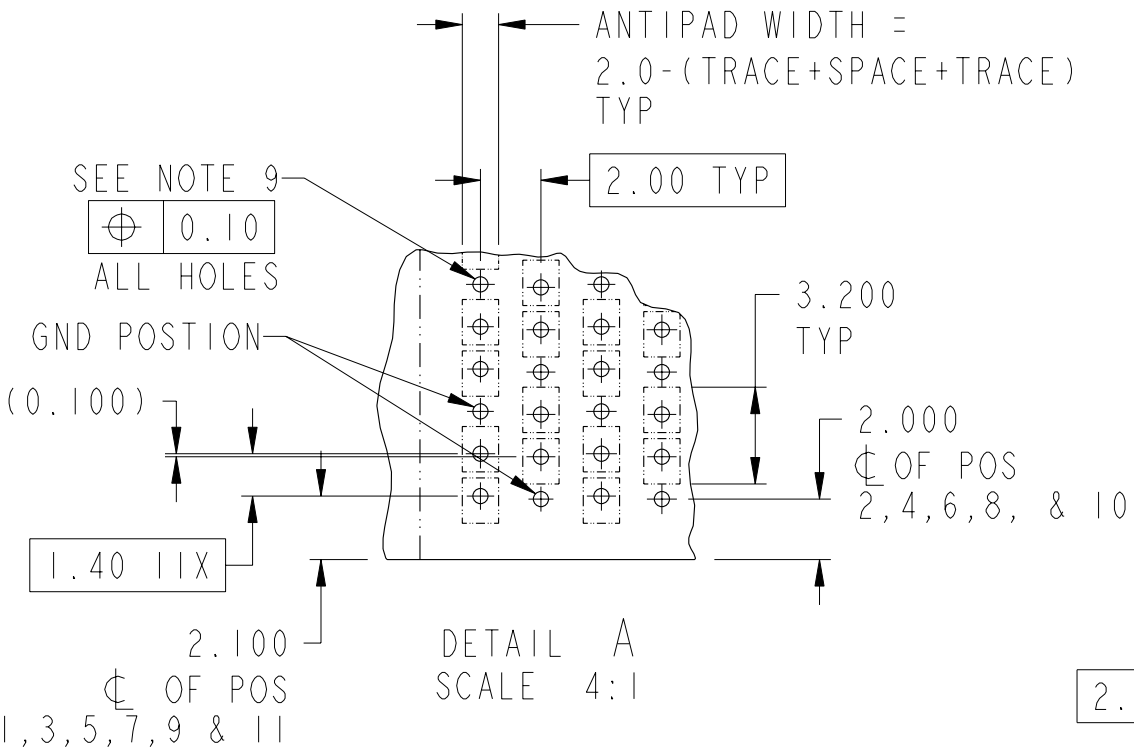

AirMax VS R/A HEADER ASSY
 PRESS-FIT, 120 POS, 22MM
 catalog no -

dwg no 10084600
 CUSTOMER

Rev. C
 sheet 4 of 5

PART NUMBER	PRESS-FIT TAIL PLATING TYPE	SHORT DETECT CONTACT
10084600-101LF	TIN OVER NICKEL (LEAD FREE)	NO
10084600-111LF	TIN OVER NICKEL (LEAD FREE)	YES (SEE NOTE 13)

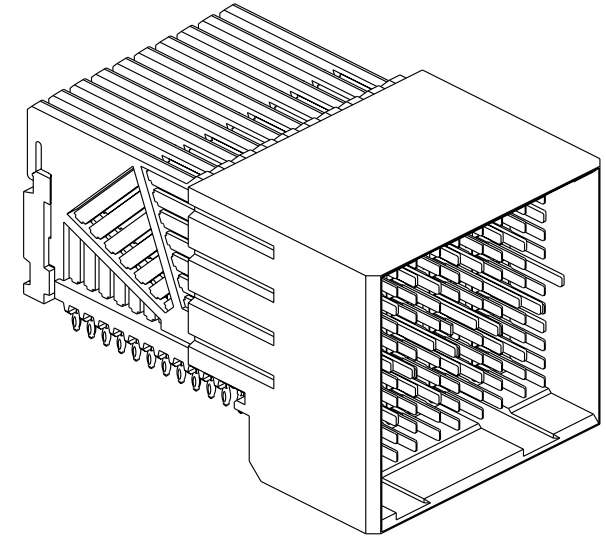

NOTES:

1. CONNECTOR MATERIALS:
 HOUSING & RETAINER: HIGH TEMP THERMOPLASTIC, NATURAL, UL94V-0
 IMLA PLASTIC: HIGH TEMP THERMOPLASTIC, BLACK, UL94V-0
 CONTACT: COPPER ALLOY

2. CONTACT PLATING:
 SEPARABLE INTERFACE:
 PERFORMANCE-BASED PLATING, QUALIFIED TO MEET THE REQUIREMENTS OF FCI PRODUCT SPECIFICATION GS-12-239, INCLUDING TELCORDIA GR-1217-CORE (NOVEMBER 1995) CENTRAL OFFICE.
 PRESS-FIT TAILS: SEE TABLE

3. PRODUCT SPECIFICATION: GS-12-239

4. APPLICATION SPECIFICATION: GS-20-035

5. PRODUCT MARKING, (PART NUMBER & LOT CODE), ON THIS SURFACE

6. REFER TO CUSTOMER DRAWING 10035911 FOR INFORMATION REGARDING PCB LAYOUT OF POWER AND GUIDE MODULES RELATIVE TO SIGNAL MODULES

7. POSITIONS F OF ODD NUMBERED COLUMNS AND POSITIONS G OF EVEN NUMBERED COLUMNS CORRESPOND TO EARLY MATE HEADER PINS

8. THERE IS NO GROUND BUSSING WITHIN THE CONNECTOR SYSTEM

9. REFER TO CUSTOMER DRAWING 10045979 FOR INFORMATION ON PCB HOLE DIAMETERS AND PLATING OPTIONS.

10. THIS PRODUCT MEETS EUROPEAN UNION DIRECTIVES AND OTHER COUNTRY REGULATIONS AS DESCRIBED IN GS-22-008.

11. THE HOUSING WILL WITHSTAND EXPOSURE TO 260°C PEAK TEMPERATURE FOR 40 SECONDS IN A CONVECTION, INFRA-RED OR VAPOR PHASE REFLOW OVEN.

12. PACKAGING MEETS GS-14-920 LEAD FREE LABELING SPECIFICATION.

13. MATING PIN F6 IS SHORTER THAN THE REMAINING SIGNAL PIN. NOMINAL MATING WIPE FOR PIN F6 IS 0.5MM LESS THAN ALL REMAINING SIGNAL PINS.

14. A  SYMBOL WILL BE NEXT TO ANY DIMENSION, VIEW, OR NOTE WHICH HAS BEEN MODIFIED WITH THE CURRENT DRAWING REVISION.



Copyright FCI.

	title AirMax VS R/A HEADER ASSY PRESS-FIT, 120 POS, 22MM	dwg no 10084600	Rev. C
	catalog no -	CUSTOMER	sheet 5 of 5