

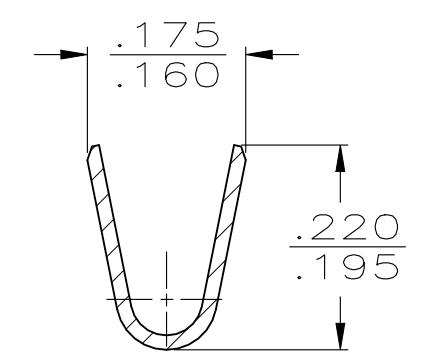

REVISIONS					
P	LTR	DESCRIPTION	DATE	DWN	APVD
	F1	REVISED PER ECR-21-113405	31MAY2022	SS	DH

- 1 CONTINUOUS STRIP ON REELS
- 2 THE GAP ON THE ROLLS TO BE IN CONTACT WITH THE TAB FOR THE LENGTH OF THE ROLL BEHIND THE LEAD-IN.

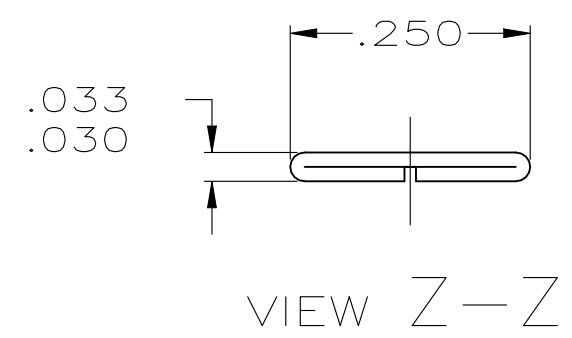
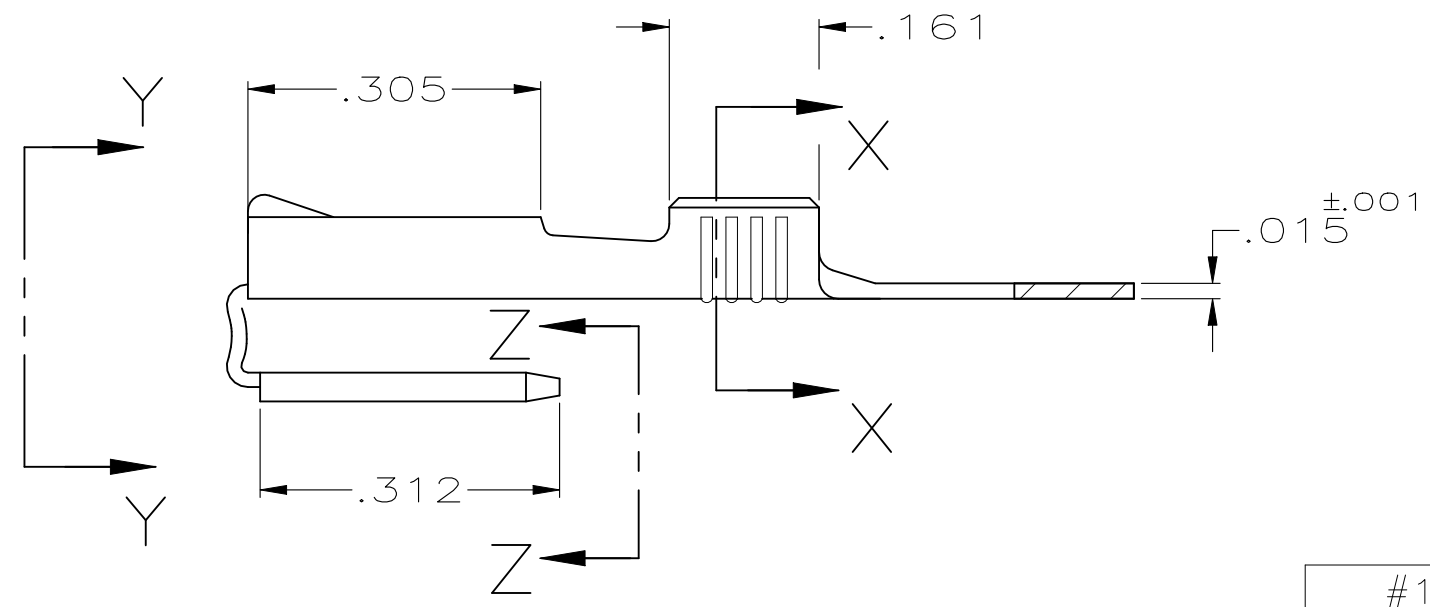
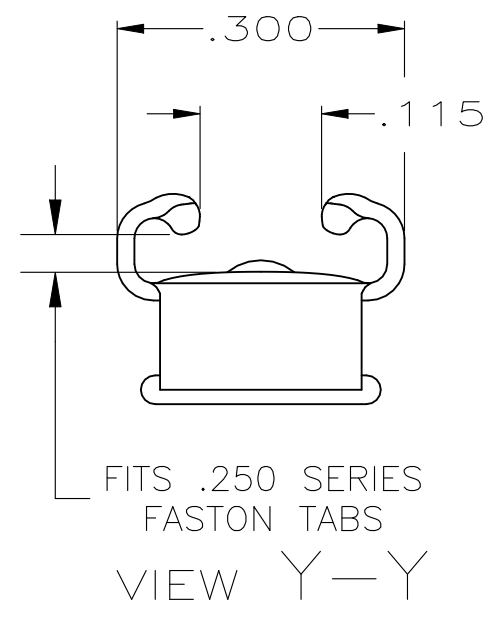
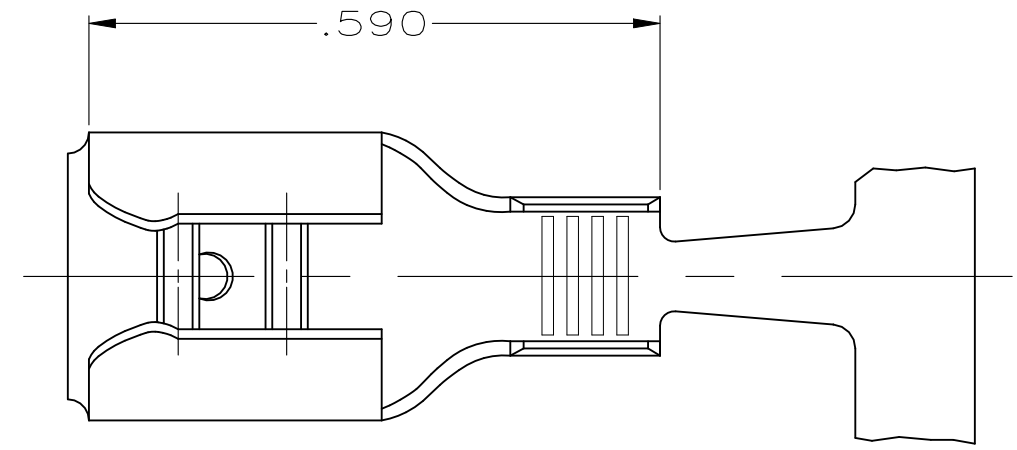

#14-#10 AWG - 9600 CMA MAX	.032	62068-1
WIRE SIZE	MATING TAB THK ±.001	PART NO.

THIS DRAWING IS A CONTROLLED DOCUMENT.		DWN JR RUTH 4/11/91	 TE Connectivity RECEPTACLE, PIGGYBACK, FASTON, .250 SERIES											
DIMENSIONS: INCHES		CHK MS FEHER 4/11/91												
TOLERANCES UNLESS OTHERWISE SPECIFIED:		APVD C MEYERS 4/11/91												
<table border="1"> <tr><td>0 PLC</td><td>± -</td></tr> <tr><td>1 PLC</td><td>± -</td></tr> <tr><td>2 PLC</td><td>± -</td></tr> <tr><td>3 PLC</td><td>± .015</td></tr> <tr><td>4 PLC</td><td>± -</td></tr> <tr><td>ANGLES</td><td>± -</td></tr> </table>		0 PLC				± -	1 PLC	± -	2 PLC	± -	3 PLC	± .015	4 PLC	± -
0 PLC	± -													
1 PLC	± -													
2 PLC	± -													
3 PLC	± .015													
4 PLC	± -													
ANGLES	± -													
MATERIAL BRASS	FINISH PRE-TIN	PRODUCT SPEC -	APPLICATION SPEC -	SIZE A3	CAGE CODE 00779	DRAWING NO C-62068	RESTRICTED TO -							
CUSTOMER DRAWING			WEIGHT 0.000000	SCALE 5:1	SHEET 1 OF 1	REV F1								