



Thomas Research Products

SSL Solutions Faster Than The Speed Of Light®

TR-SS1 LED Core™ Integrated LED Canopy Module Patented Design, with 0-10V Dimming

- Die-cast single piece aluminum body
- UV stabilized polycarbonate lens with injection-molded frame
- Universal voltage (100-277Vac)
- Patented design is robust, for superb durability
- Modular: Key components can be refurbished
- Type V short

TR-SS1 Integrated LED Canopy Module is designed to seamlessly integrate into just about any canopy fixture. We have taken the tedious engineering task out of designing an LED solution.

Combining cutting-edge optical characteristics and integrated LED driver, it's simpler than ever. We can provide your engineering staff a full set of CAD files to speed along the integration process.

Includes 0-10V Dimming as standard.

Electrical:

Class 1 and 2 power supplies accommodate an input voltage range of 100-277V 50/60Hz. All power supplies provide Class A EMI rating with high power factor of 90% typical.

Mounting:

Custom fixture mount only. CAD and Step files available to streamline integration. Fixture cut out pattern show on next page.

Exterior Surface Finish:

Powder coated die-cast aluminum.

Testing and Compliance:

The TR-SS1 meets UL8750 specifications. Contact our engineering staff for assistance in certifying your fixture.

Lumen Maintenance:

Lumen maintenance will vary substantially based upon fixture in which the TR-SS1 is mounted. Additional heat dissipating capacity from fixture is highly recommended to maximize lumen maintenance. Lumen maintenance to be determined by using LM80, in situ thermal data in accordance with DOE/EPA standards and reliability data supplied by LED Manufacturer.

- Maintains a tolerance of $\pm 7\%$ on flux measurements.
- Published output measurements using 4500K.
- Typical CRI for Neutral White (5000K) is 75.
- Output lumens will vary depending on factors involved with fixture integration.
- 5 year limited warranty with validation of fixture.

Environmental Impact

- RoHS Compliant
- No mercury
- Reduction in Kw load by as much as 60%



SS1 Series LED Canopy Module					
Model Number	System Power	Initial Delivered Lumens	Lumens Per Watt	Replaces HID lamp*	Energy Savings†
TR-SS1-e36C	41W	2925	71*	70W HPS	50W
TR-SS1-e48C	55W	3900	71*	100W HPS	75W
TR-SS1-e72C	75W	5848	71*	150W MH	128W

* Based on Mean Lumens

† Compares LED Core™ system wattage to avg. HID ballast input wattage



Specifications subject to change without notice.

7-09-13



Thomas Research Products

SSL Solutions Faster Than The Speed Of Light®

TR-SS1-C

Pg 2 of 2

Photometrics

TR-SS1 Canopy Type V Short:
Tested to IESNA LM-79 standard
by an independent testing laboratory.

TR-SS1-72C Photometric Data

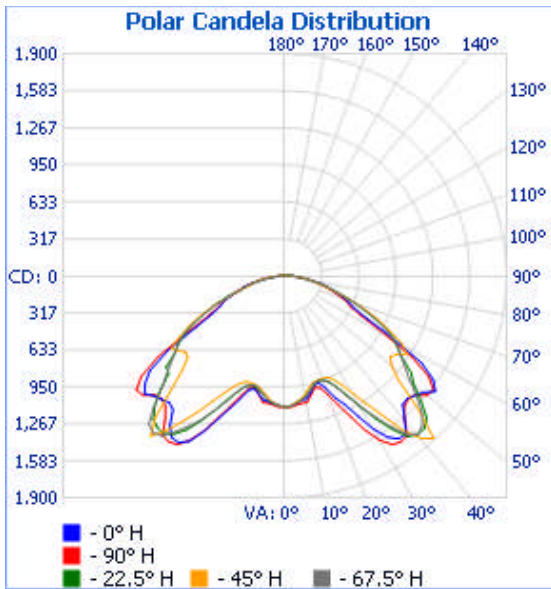

Dimensions

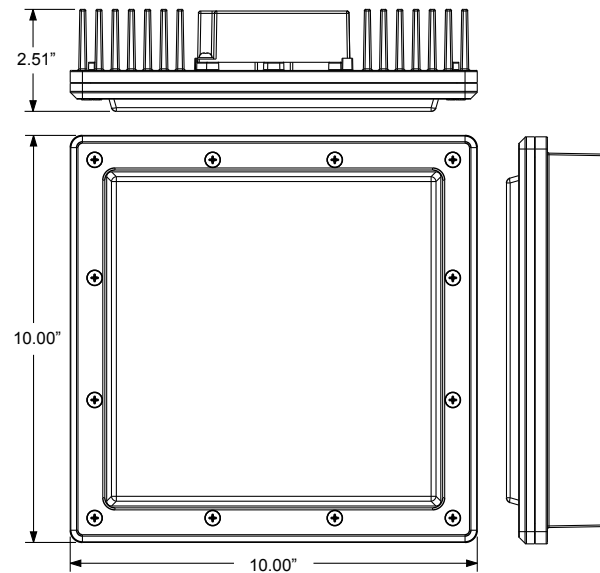

Mounting

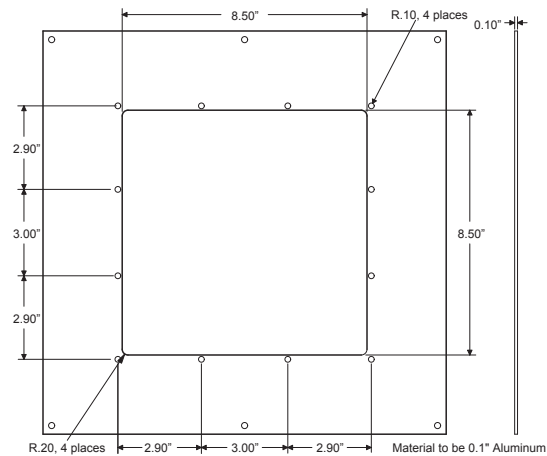

Mounting Examples:
Canopy Luminaires



Application Notes:

- 1) The LED Core™ is intended to be mounted to a flange of the fixture, situated between the LED Core™ module's lens frame/lens/gasket and aluminum body in order to qualify for IP rating. (See detail.)
- 2) The LED Core™ module can be mounted to the fixture flange on the backside of the module's body. Mounting holes are not provided. This is not recommended as it will not achieve an IP rating.

