

GaAs MMIC SP6T NON-REFLECTIVE SWITCH, DC - 3 GHz

Typical Applications

The HMC252AQS24E is ideal for:

- Base Station
- CATV / DBS
- MMDS & WirelessLAN
- Test Equipment

Features

- Low Insertion Loss (2 GHz): 1.0 dB
- Single Positive Supply: $V_{DD} = +3V$ to $+5V$
- Integrated 3:6 TTL Decoder
- 24 Lead QSOP Package

Functional Diagram

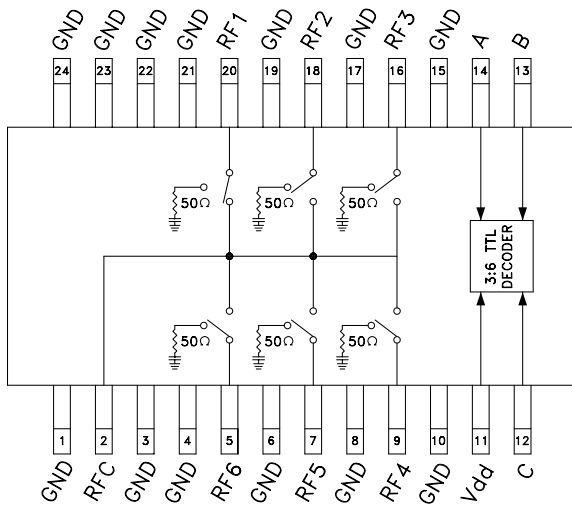

General Description

The HMC252AQS24E is low-cost non-reflective SP6T switches in 24-lead QSOP packages featuring wideband operation from DC to 3.0 GHz. The switch offers a single positive bias and true TTL/CMOS compatibility. A 3:6 decoder is integrated on the switch requiring only 3 control lines and a positive bias to select each path. The HMC252AQS24E SP6T replaces multiple configurations of SP4T and SPDT MMIC switches and logic drivers.

Electrical Specifications,

$T_A = +25^\circ C$, For TTL Control and $V_{DD} = +3.3V, 5V$ in a 50 Ohm System

Parameter	Frequency	Min.	Typ.	Max.	Min.	Typ.	Max.	Units
		Vdd = +3.3V			Vdd = +5V			
Insertion Loss	DC - 1.0 GHz		0.8			0.8	1.2	dB
	DC - 2.0 GHz		1.0			1.0	1.3	
	DC - 2.5 GHz		1.2			1.2	1.5	
	DC - 3.0 GHz		1.4			1.4	1.8	
Isolation	DC - 1.0 GHz		45		38	45		dB
	DC - 2.0 GHz		40		32	40		
	DC - 2.5 GHz		38		29	38		
	DC - 3.0 GHz		32		26	32		
Return Loss	"On State"	DC - 1 GHz		23		14	23	dB
		DC - 2.5 GHz		18		14	18	
		DC - 3.0 GHz		12		7	12	
Return Loss	RF1-6 "Off State"	0.3 - 1 GHz		11		8	11	dB
		0.3 - 3.0 GHz		12		8	12	
		0.5 - 2.5 GHz		15		11	15	
Input Power for 1dB Compression	0.1 - 1.0 GHz		24			30		dBm
	0.3 - 3.0 GHz		24		21	28		
Input Third Order Intercept (Two-Tone Input Power = +10 dBm Each Tone)	0.3 - 3.0 GHz		47		42	47		dBm
Switching Characteristics								
tRISE, tFALL (10/90% RF)	0.3 - 3.0 GHz		20			25		ns
tON, tOFF (50% CTL to 10/90% RF)			70			90		

Information furnished by Analog Devices is believed to be accurate and reliable. However, no responsibility is assumed by Analog Devices for its use, nor for any infringements of patents or other rights of third parties that may result from its use. Specifications subject to change without notice. No license is granted by implication or otherwise under any patent or patent rights of Analog Devices. Trademarks and registered trademarks are the property of their respective owners.

For price, delivery, and to place orders: Analog Devices, Inc., One Technology Way, P.O. Box 9106, Norwood, MA 02062-9106 Phone: 781-329-4700 • Order online at www.analog.com Application Support: Phone: 1-800-ANALOG-D

GaAs MMIC SP6T NON-REFLECTIVE SWITCH, DC - 3 GHz

Insertion Loss [1]

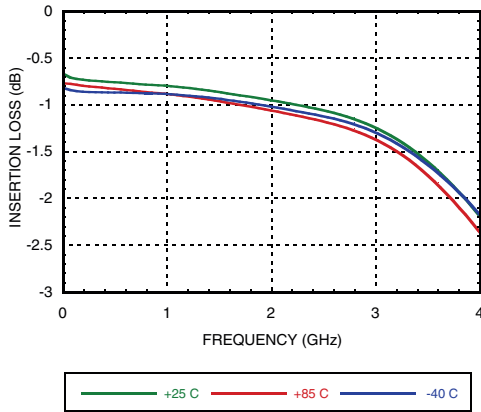

Isolation [1]

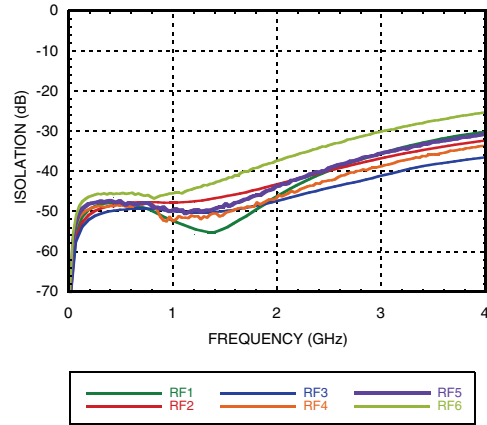

Return Loss [1]

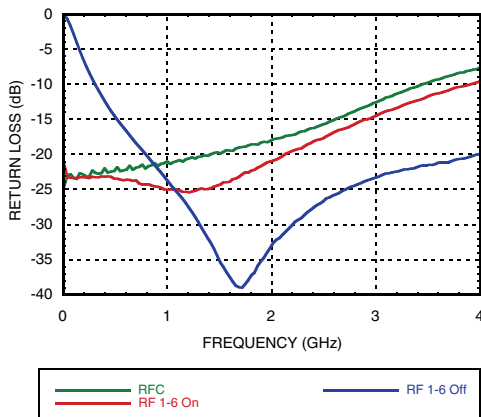

Input Compression

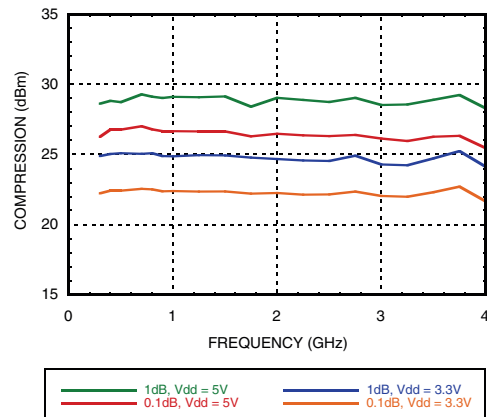

Input Third Order Intercept Point

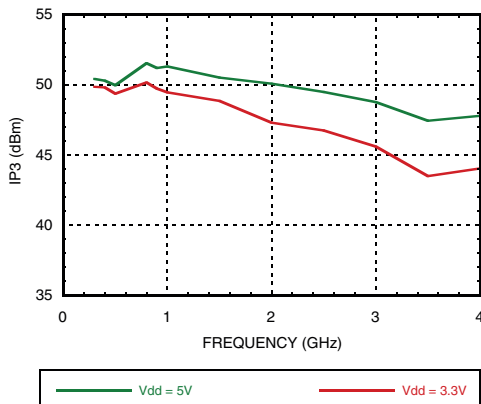

Bias Voltages & Currents

V _{DD} (V)	I _{DD} (Typ.) (mA)	I _{DD} (Max.) (mA)
+3.3 (V _{dc} ± 5%)	3.3	7
+5.0 (V _{dc} ± 10%)	3.5	7

TTL/CMOS Control Voltages

V _{DD} (V)	State	Bias Condition
+3.3	Low	0 to +0.8 V _{dc} @ 1μA Typ.
	High	+2.0 to +3.3 V _{dc} @ 50 μA Typ.
+5.0	Low	0 to +0.8 V _{dc} @ 2μA Typ.
	High	+2.0 to +5 V _{dc} @ 60 μA Typ.

[1] V_{DD} = 5V

NOTE:

- DC Blocking capacitors are required at ports RFC and RF1, 2, 3, 4, 5, 6.
- Input is reflective when "ALL OFF" state is selected.

GaAs MMIC SP6T NON-REFLECTIVE SWITCH, DC - 3 GHz

Absolute Maximum Ratings

Bias Voltage Range (Port Vdd)	+7 Vdc
Control Voltage Range (A, B, C)	-0.5V to Vdd +1 Vdc
Channel Temperature	150 °C
Thermal Resistance	
Insertion Loss Path	130 °C/W
Terminated Path	236 °C/W
Storage Temperature	-65 to +150 °C
Operating Temperature	-40 to +85 °C
Maximum Input Power Vdd = +5 Vdc	
Insertion Loss Path	+29.8 dBm
Terminated Path	+24.4 dBm
ESD Sensitivity (HBM)	Class 1A

Truth Table

Control Input			Signal Path State
A	B	C	RFCOM to:
LOW	LOW	LOW	RF1
HIGH	LOW	LOW	RF2
LOW	HIGH	LOW	RF3
HIGH	HIGH	LOW	RF4
LOW	LOW	HIGH	RF5
HIGH	LOW	HIGH	RF6
LOW	HIGH	HIGH	ALL OFF
HIGH	HIGH	HIGH	ALL OFF



ELECTROSTATIC SENSITIVE DEVICE
OBSERVE HANDLING PRECAUTIONS

Outline Drawing

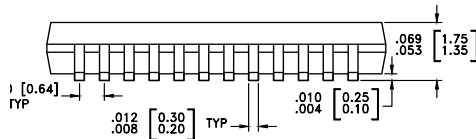
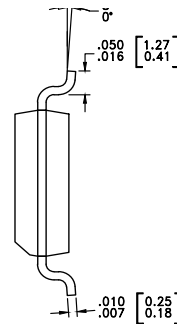
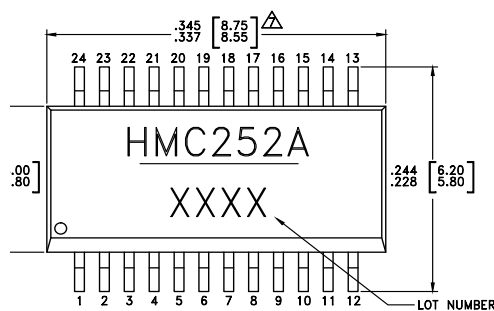

NOTES:

1. PACKAGE BODY MATERIAL: LOW STRESS INJECTION MOLDED PLASTIC SILICA AND SILICON IMPREGNATED.
2. LEAD MATERIAL: COPPER ALLOY.
3. LEAD PLATING: 100% MATTE TIN.
4. DIMENSIONS ARE IN INCHES [MILLIMETERS].
5. CHARACTERS TO BE HELVETICA MEDIUM, .030 HIGH, LASER OR WHITE INK, LOCATED APPROXIMATELY AS SHOWN.
- △ DIMENSION DOES NOT INCLUDE MOLDFLASH OF 0.15mm PER SIDE.
- △ DIMENSION DOES NOT INCLUDE MOLDFLASH OF 0.25mm PER SIDE.
8. ALL GROUND LEADS MUST BE SOLDERED TO PCB RF GROUND.

Package Information

Part Number	Package Body Material	Lead Finish	MSL Rating	Package Marking ^[2]
HMC252AQS24E	RoHS-compliant Low Stress Injection Molded Plastic	100% matte Sn	MSL1 ^[1]	HMC252A XXXX

[1] Max peak reflow temperature of 260 °C

[2] 4-Digit lot number XXXX

GaAs MMIC SP6T NON-REFLECTIVE SWITCH, DC - 3 GHz

Evaluation Circuit Board

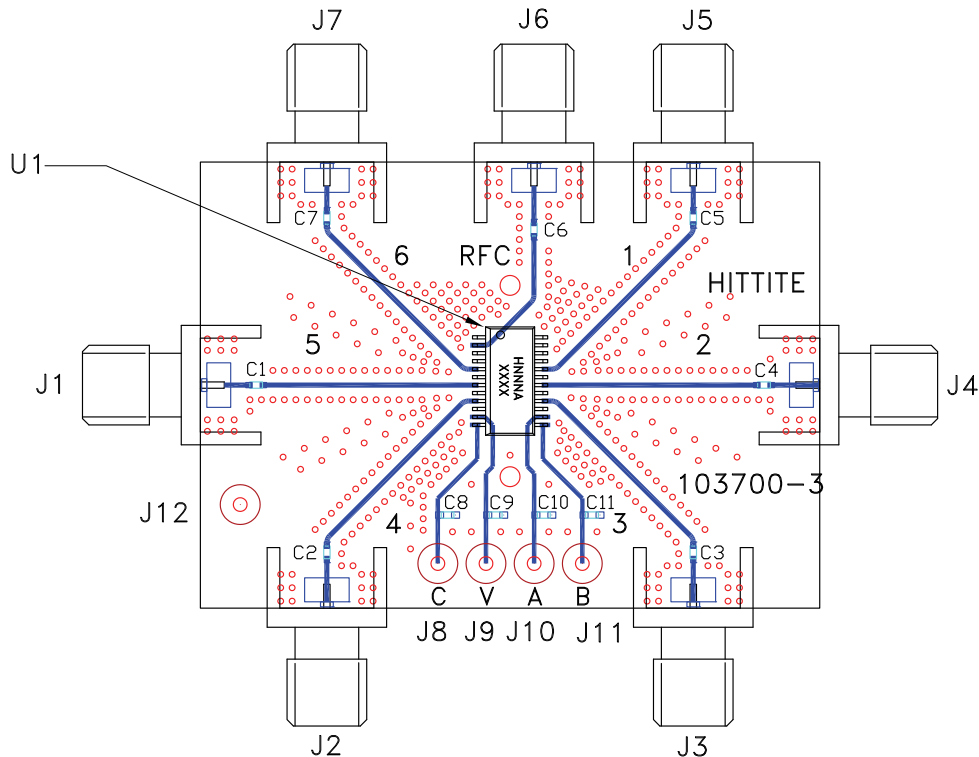

List of Materials for Evaluation PCB EV1HMC252AQS24 [1]

Item	Description
J1 - J7	PCB Mount SMA Connector
J8 - J12	DC Pin
C1 - C7	100 pF Capacitor, 0402 Pkg.
C8 - C11	10,000 pF Capacitor, 0603 Pkg.
U1	HMC252AQS24E SP6T Switch
PCB [2]	103700 Eval Board

[1] Reference this number when ordering complete evaluation PCB

[2] Circuit Board Material: Rogers 4350

The circuit board used in the application should be generated with proper RF circuit design techniques. Signal lines at the RF ports should have 50 ohm impedance while the package ground leads should be connected directly to the ground plane similar to that shown above. A sufficient number of via holes should be used to connect the top and bottom ground planes. The evaluation circuit board shown above is available from Analog Devices Inc. upon request.