

PmodCLS[™] Reference Manual

Revised April 8, 2016

This manual applies to the PmodCLS rev. D-E

Overview

The Digilent PmodCLS is a 16x2 character LCD module driven by an Atmel[®] [ATmega48](#) microcontroller.

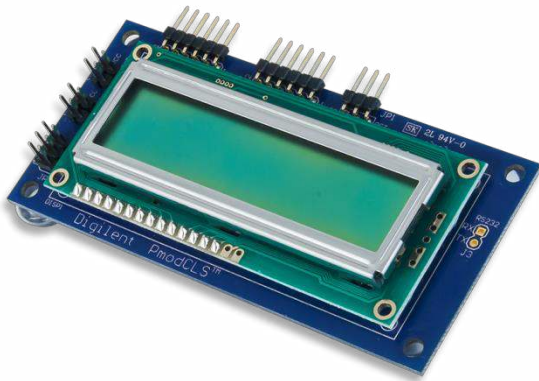

The PmodCLS.

Features include:

- 16x2 liquid crystal character display
- Wide range of instruction functions
- Up to 32 user definable characters
- Multiple communication options including UART, SPI, and I²C
- Small PCB size for flexible designs 1.8" × 3.8" (4.6 cm × 9.7 cm)
- Two 1x6-pin Pmod ports with SPI and UART interfaces
- Library and example code available in resource center

1 Functional Description

The PmodCLS module can be used to display important information during program development or as a user interface after the project has been completed. The module is ideally suited for microcontroller boards but can also be used in projects using a FPGA board.

The module is capable of executing a variety of instructions such as erasing specific characters, setting different display modes, scrolling, and displaying user-defined characters. These instructions are specified using escape sequences to send commands to the board's embedded Atmel ATmega48 microcontroller. The display on the module is driven by this AVR and controls all of the features of the board.

2 Interfacing with the Pmod

The PmodCLS can communicate with the host board through the SPI, I²C, and UART ports.

Through these protocol standards, users are able to set the cursor location and send other instructions by sending escape sequences. And escape sequence is specified by first sending the escape character (0x1B) followed by a left square bracket '[' (0x5B), and then one or more numeric parameters followed by the command character for the specific command. Feel free to use our provided [example code](#).

Header J1		
Pin	Signal	Description
1	SS	Slave Select
2	MOSI	Master-Out-Slave-In
3	MISO	Master-In-Slave-Out
4	SCK	Serial Clock
5	GND	Power Supply Ground
6	VCC	Positive Power Supply (3.3V)

Table 1. J1 pinout description table.

Header J2		
Pin	Signal	Description
1	SCL	Serial Clock
2	SDA	Serial Data
3	TXD	Transmit Data
4	RXD	Receive Data
5	GND	Power Supply Ground
6	VCC	Positive Power Supply (3.3V)

Table 2. J2 pinout description table.

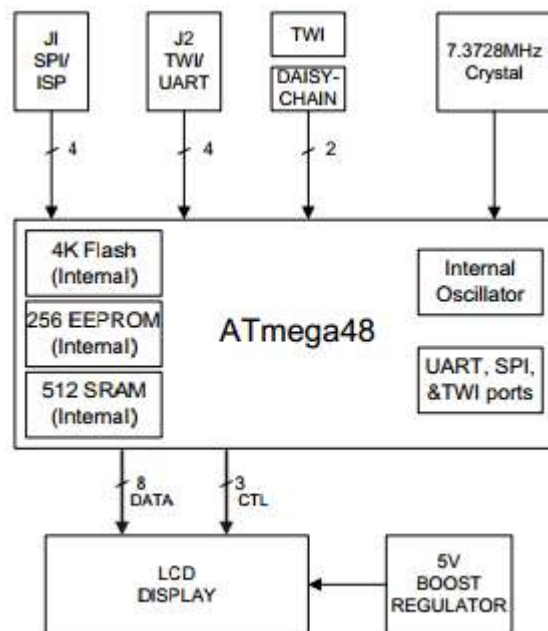

Figure 1. PmodCLS block diagram.

2.1 Communication Protocol Selection

You can set the board's communication method by setting the mode jumpers MD0, MD1, and MD2 on the board. Possible mode jumper configurations are listed in Table 3 below. For rev. D boards, a missing jumper is represented by a '0' and a connected jumper is represented by '1'. For rev. E boards, a missing jumper is represented by a '1' and a connected jumper is represented by a '0'.

MD2, MD1, MD0	Protocol	Details
0,0,0	UART	2400 baud
0,0,1	UART	4800 baud
0,1,0	UART	9600 baud
0,1,1	UART	Baud rate in EEPROM
1,0,0	TWI	Address: 0x48
1,0,1	TWI	Address in EEPROM
1,1,0	SPI	
1,1,1	Specified in EEPROM	Specified in EEPROM

Table 3. Mode jumper configurations.

Any external power applied to the PmodCLS must be within 2.7V and 5.5V; if you are powering the Pmod from its VCC pin, you must operate the Pmod at 3.3V in order for the on-board step-up switching regulator to work correctly.

3 Physical Dimensions

The pins on the pin header are spaced 100 mil apart. The PCB is 1.8 inches long on the sides parallel to the pins on the pin header and 3.8 inches long on the sides perpendicular to the pin header.